

# Parker Worldwide

## Europe, Middle East, Africa

**AE – United Arab Emirates,** Dubai  
Tel: +971 4 8127100  
parker.me@parker.com

**AT – Austria,** Wiener Neustadt  
Tel: +43 (0)2622 23501-0  
parker.austria@parker.com

**AT – Eastern Europe,** Wiener Neustadt  
Tel: +43 (0)2622 23501 900  
parker.easteurope@parker.com

**AZ – Azerbaijan,** Baku  
Tel: +994 50 2233 458  
parker.azerbaijan@parker.com

**BE/LU – Belgium,** Nivelles  
Tel: +32 (0)67 280 900  
parker.belgium@parker.com

**BY – Belarus,** Minsk  
Tel: +375 17 209 9399  
parker.belarus@parker.com

**CH – Switzerland,** Etoy  
Tel: +41 (0)21 821 87 00  
parker.switzerland@parker.com

**CZ – Czech Republic,** Klecany  
Tel: +420 284 083 111  
parker.czechrepublic@parker.com

**DE – Germany,** Kaarst  
Tel: +49 (0)2131 4016 0  
parker.germany@parker.com

**DK – Denmark,** Ballerup  
Tel: +45 43 56 04 00  
parker.denmark@parker.com

**ES – Spain,** Madrid  
Tel: +34 902 330 001  
parker.spain@parker.com

**FI – Finland,** Vantaa  
Tel: +358 (0)20 753 2500  
parker.finland@parker.com

**FR – France,** Contamine s/Arve  
Tel: +33 (0)4 50 25 80 25  
parker.france@parker.com

**GR – Greece,** Athens  
Tel: +30 210 933 6450  
parker.greece@parker.com

**HU – Hungary,** Budapest  
Tel: +36 1 220 4155  
parker.hungary@parker.com

**IE – Ireland,** Dublin  
Tel: +353 (0)1 466 6370  
parker.ireland@parker.com

**IT – Italy,** Corsico (MI)  
Tel: +39 02 45 19 21  
parker.italy@parker.com

**KZ – Kazakhstan,** Almaty  
Tel: +7 7272 505 800  
parker.easteurope@parker.com

**NL – The Netherlands,** Oldenzaal  
Tel: +31 (0)541 585 000  
parker.nl@parker.com

**NO – Norway,** Asker  
Tel: +47 66 75 34 00  
parker.norway@parker.com

**PL – Poland,** Warsaw  
Tel: +48 (0)22 573 24 00  
parker.poland@parker.com

**PT – Portugal,** Leca da Palmeira  
Tel: +351 22 999 7360  
parker.portugal@parker.com

**RO – Romania,** Bucharest  
Tel: +40 21 252 1382  
parker.romania@parker.com

**RU – Russia,** Moscow  
Tel: +7 495 645-2156  
parker.russia@parker.com

**SE – Sweden,** Spånga  
Tel: +46 (0)8 59 79 50 00  
parker.sweden@parker.com

**SK – Slovakia,** Banská Bystrica  
Tel: +421 484 162 252  
parker.slovakia@parker.com

**SL – Slovenia,** Novo Mesto  
Tel: +386 7 337 6650  
parker.slovenia@parker.com

**TR – Turkey,** Istanbul  
Tel: +90 216 4997081  
parker.turkey@parker.com

**UA – Ukraine,** Kiev  
Tel: +380 44 494 2731  
parker.ukraine@parker.com

**UK – United Kingdom,** Warwick  
Tel: +44 (0)1926 317 878  
parker.uk@parker.com

**ZA – South Africa,** Kempton Park  
Tel: +27 (0)11 961 0700  
parker.southafrica@parker.com

## North America

**CA – Canada,** Milton, Ontario  
Tel: +1 905 693 3000

**US – USA,** Cleveland  
Tel: +1 216 896 3000

## Asia Pacific

**AU – Australia,** Castle Hill  
Tel: +61 (0)2-9634 7777

**CN – China,** Shanghai  
Tel: +86 21 2899 5000

**HK – Hong Kong**  
Tel: +852 2428 8008

**IN – India,** Mumbai  
Tel: +91 22 6513 7081-85

**JP – Japan,** Tokyo  
Tel: +81 (0)3 6408 3901

**KR – South Korea,** Seoul  
Tel: +82 2 559 0400

**MY – Malaysia,** Shah Alam  
Tel: +60 3 7849 0800

**NZ – New Zealand,** Mt Wellington  
Tel: +64 9 574 1744

**SG – Singapore**  
Tel: +65 6887 6300

**TH – Thailand,** Bangkok  
Tel: +662 186 7000-99

**TW – Taiwan,** Taipei  
Tel: +886 2 2298 8987

## South America

**AR – Argentina,** Buenos Aires  
Tel: +54 3327 44 4129

**BR – Brazil,** Sao Jose dos Campos  
Tel: +55 800 727 5374

**CL – Chile,** Santiago  
Tel: +56 2 623 1216

**MX – Mexico,** Apodaca  
Tel: +52 81 8156 6000

Parflange® F37 for pipe and tube connections

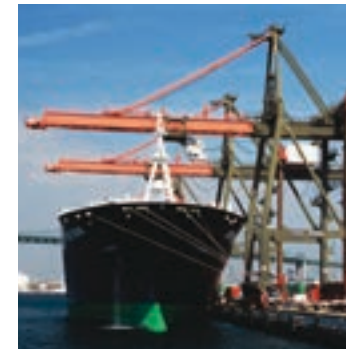

aerospace  
climate control  
electromechanical  
filtration  
fluid & gas handling  
hydraulics  
pneumatics  
process control  
sealing & shielding



Parflange® F37 for pipe and tube connections



### EMEA Product Information Centre

Free phone: 00 800 27 27 5374

(from AT, BE, CH, CZ, DE, DK, EE, ES, FI, FR, IE, IL, IS, IT, LU, MT, NL, NO, PL, PT, RU, SE, SK, UK, ZA)

### US Product Information Centre

Toll-free number: 1-800-27 27 537

www.parker.com

Your local authorized Parker distributor



ENGINEERING YOUR SUCCESS.



# Parker's Motion & Control Technologies

At Parker, we're guided by a relentless drive to help our customers become more productive and achieve higher levels of profitability by engineering the best systems for their requirements. It means looking at customer applications from many angles to find new ways to create value. Whatever the motion and control technology need, Parker has the experience, breadth of product and global reach to consistently deliver. No company knows more about motion and control technology than Parker. For further info call 00800 27 27 5374



## Aerospace

**Key Markets**  
 Aftermarket services  
 Commercial transports  
 Engines  
 General & business aviation  
 Helicopters  
 Launch vehicles  
 Military aircraft  
 Missiles  
 Power generation  
 Regional transports  
 Unmanned aerial vehicles

## Key Products

Control systems & actuation products  
 Engine systems & components  
 Fluid conveyance systems & components  
 Fluid metering, delivery & atomization devices  
 Fuel systems & components  
 Fuel tank inerting systems  
 Hydraulic systems & components  
 Thermal management  
 Wheels & brakes



## Climate Control

**Key Markets**  
 Agriculture  
 Air conditioning  
 Construction Machinery  
 Food & beverage  
 Industrial machinery  
 Life sciences  
 Oil & gas  
 Precision cooling  
 Process  
 Refrigeration  
 Transportation

## Key Products

AC/DC drives & systems  
 Advanced actuators  
 CO<sub>2</sub> controls  
 Electronic controllers  
 Filter driers  
 Hand shut-off valves  
 Heat exchangers  
 Hose & fittings  
 Pressure regulating valves  
 Refrigerant distributors  
 Safety relief valves  
 Smart pumps  
 Solenoid valves  
 Thermostatic expansion valves



## Electromechanical

**Key Markets**  
 Aerospace  
 Factory automation  
 Life science & medical  
 Machine tools  
 Packaging machinery  
 Paper machinery  
 Plastics machinery & converting  
 Primary metals  
 Semiconductor & electronics  
 Textile  
 Wire & cable

## Key Products

Accumulators  
 Electric actuators, gantry robots & slides  
 Electrohydraulic actuation systems  
 Electromechanical actuation systems  
 Human machine interface  
 Linear motors  
 Stepper motors, servo motors, drives & controls  
 Structural extrusions



## Filtration

**Key Markets**  
 Aerospace  
 Food & beverage  
 Industrial plant & equipment  
 Life sciences  
 Marine  
 Mobile equipment  
 Oil & gas  
 Power generation & renewable energy  
 Process  
 Transportation  
 Water Purification

## Key Products

Analytical gas generators  
 Compressed air filters & dryers  
 Engine air, coolant, fuel & oil filtration systems  
 Fluid condition monitoring systems  
 Hydraulic & lubrication filters  
 Hydrogen, nitrogen & zero air generators  
 Instrumentation filters  
 Membrane & fiber filters  
 Microfiltration  
 Sterile air filtration  
 Water desalination & purification filters & systems



## Fluid & Gas Handling

### Key Markets

Aerial lift  
 Agriculture  
 Bulk chemical handling  
 Construction machinery  
 Food & beverage  
 Fuel & gas delivery  
 Industrial machinery  
 Life sciences  
 Marine  
 Mining  
 Mobile  
 Oil & gas  
 Renewable energy  
 Transportation

### Key Products

Check valves  
 Connectors for low pressure fluid conveyance  
 Deep sea umbilicals  
 Diagnostic equipment  
 Hose couplings  
 Industrial hose  
 Mooring systems & power cables  
 PTFE hose & tubing  
 Quick couplings  
 Rubber & thermoplastic hose  
 Tube fittings & adapters  
 Tubing & plastic fittings



## Hydraulics

### Key Markets

Aerial lift  
 Agriculture  
 Alternative energy  
 Construction machinery  
 Forestry  
 Industrial machinery  
 Machine tools  
 Marine  
 Material handling  
 Mining  
 Oil & gas  
 Power generation  
 Refuse vehicles  
 Renewable energy  
 Truck hydraulics  
 Turf equipment

### Key Products

Accumulators  
 Cartridge valves  
 Electrohydraulic actuators  
 Human machine interfaces  
 Hybrid drives  
 Hydraulic cylinders  
 Hydraulic motors & pumps  
 Hydraulic systems  
 Hydraulic valves & controls  
 Hydrostatic steering  
 Integrated hydraulic circuits  
 Power take-offs  
 Power units  
 Rotary actuators  
 Sensors



## Pneumatics

### Key Markets

Aerospace  
 Conveyor & material handling  
 Factory automation  
 Life science & medical  
 Machine tools  
 Packaging machinery  
 Transportation & automotive

### Key Products

Air preparation  
 Brass fittings & valves  
 Manifolds  
 Pneumatic accessories  
 Pneumatic actuators & grippers  
 Pneumatic valves & controls  
 Quick disconnects  
 Rotary actuators  
 Rubber & thermoplastic hose & couplings  
 Structural extrusions  
 Thermoplastic tubing & fittings  
 Vacuum generators, cups & sensors



## Process Control

### Key Markets

Alternative fuels  
 Biopharmaceuticals  
 Chemical & refining  
 Food & beverage  
 Marine & shipbuilding  
 Medical & dental  
 Microelectronics  
 Nuclear Power  
 Offshore oil exploration  
 Oil & gas  
 Pharmaceuticals  
 Power generation  
 Pulp & paper  
 Steel  
 Water/wastewater

### Key Products

Analytical Instruments  
 Analytical sample conditioning products & systems  
 Chemical injection fittings & valves  
 Fluoropolymer chemical delivery fittings, valves & pumps  
 High purity gas delivery fittings, valves, regulators & digital flow controllers  
 Industrial mass flow meters/ controllers  
 Permanent no-weld tube fittings  
 Precision industrial regulators & flow controllers  
 Process control double block & bleeds  
 Process control fittings, valves, regulators & manifold valves



## Sealing & Shielding

### Key Markets

Aerospace  
 Chemical processing  
 Consumer  
 Fluid power  
 General industrial  
 Information technology  
 Life sciences  
 Microelectronics  
 Military  
 Oil & gas  
 Power generation  
 Renewable energy  
 Telecommunications  
 Transportation

### Key Products

Dynamic seals  
 Elastomeric o-rings  
 Electro-medical instrument design & assembly  
 EMI shielding  
 Extruded & precision-cut, fabricated elastomeric seals  
 High temperature metal seals  
 Homogeneous & inserted elastomeric shapes  
 Medical device fabrication & assembly  
 Metal & plastic retained composite seals  
 Shielded optical windows  
 Silicone tubing & extrusions  
 Thermal management  
 Vibration dampening

## Approval and Certification requirements

**Note! Customer has to specify needed certifications, classifications, testing and inspection requirements precisely when requesting quotation/placing an order.**

## For your safety!

Under certain circumstances, tube fittings can be subjected to extreme loadings such as vibration and uncontrolled pressure peaks.

Only by using genuine Parker components and following Parker assembly instructions can you be assured of the reliability and safety of the products and their conformity to the applicable standards.

Failure to follow this rule can adversely affect the functional safety and reliability of products, cause personal injury, property damage, and result in loss of your guarantee rights.

Subject to alteration



**Table of contents**

Introduction..... page 4

General information..... 7

Technical data..... 19

Installation ..... 23

Machines, tooling and equipment ..... 25

Ordering information/Nomenclature ..... 43

SAE 1000 System..... 47

SAE 3000 System..... 71

SAE 6000 System..... 115

ISO 6164 System ..... 157

Flange mounted valves ..... 195

SAE Flange adapters..... 201

Tube clamps..... 221

Pipes and tubes..... 255



Tube Fittings Division Europe

# The Tube Fittings Authority:

## Performance Plus

Since 1929, Parker Hannifin Corporation has served the marketplace with dependable fluid power technology. Today, Parker offers more than 100,000 quality products for a broad range of industries and applications. No other manufacturer presents a product line as broad as Parker's, nor an expertise as far-reaching in hydraulic and pneumatic systems and components. Much of that expertise originates with Parker's precision-made tube fittings, which were among the first products manufactured by the company. As such, they reflect Parker's ongoing commitment to excellence.

With more than seventy years of experience in product design, engineering, applications technology and manufacturing, the Tube Fittings Division Europe holds a leadership position few other manufacturers can claim. This leadership is further heightened and enhanced by the sharing of technology only possible in Parker's corporate family.

## Topflight Experience

Parker has used the background data and knowledge gained from important industrial, mobile, offshore and other applications to create the broadest and best performing line of standard tube fittings in the world.

## Why is Parker a topflight manufacturer of fittings?

There are many reasons, but at the heart is the design and manufacturing excellence that goes into every Parker product.

## Worldwide standardizing activities

The Parker Fluid Connectors Group supports the national and international standardizing activities. Experienced engineers from certain countries and Divisions give their input to national committees like SAE, BS, and DIN committees in cooperation with the users of the products. As a result, many ISO Fluid Connector standards have been published. These ISO standards are the platform for the international trading, interchangeability and availability that is necessary for all globally operating companies using fluid power technology.







ENGINEERING YOUR SUCCESS.





## **General information**



### Parflange® F37 technology

#### Parflange® technology

Parker is the inventor of the Parflange® system and knows well how to deal with flared tubes and flanged connectors. The excellent sealing performance and the high mechanical strength of Parflange® technology are achieved by continuous orbital tube forming. Proven millions of times, this connector system is backed by decades of experience. The Parflange® system belongs to Parker's leak-free Dry Technology programme. Dry Technology stands for leak-free systems with soft sealing at every connection point.

#### Parflange® F37

The Parflange® F37 flanged connector system is utilising this orbital tube forming technology for tubing assemblies from 16 to 165 mm (1/2" to 6" Flanges) outside diameter. It is intended for tube wall thickness up to 9 mm and pressure ratings up to 420 bar.

For those connections, where there is no possibility to assemble a pre-flared tube or where manufacturing is limited, Parker provides the F37 Retaining Ring System. This System utilizes a Retaining Ring for flange retention along with a highly-engineered seal carrier for leak free performance. It is available as a high pressure version from 1 1/2" to 10" and as a newly developed SAE 1000 (50-70 bar) version.

The Parflange® F37 system corresponds to hole patterns according to ISO 6162-1; SAE J518; bore pattern 3000 (code 61), ISO 6162-2; bore pattern 6000 (code 62) and also ISO 6164 bore pattern.

It is type approved by DNV, ABS and other major classification companies.

#### Protected from corrosion and even Cr(VI)-free

As a manufacturer of large flange connectors, Parker is employing Cr(VI)-free corrosion protection on Parflange F37, as it has already done with its other Fluid Connector Products. The removal of Cr(VI) reflects Parker's ongoing commitment to an environmentally clean and safe production process.

#### Different Sealing Solution

The F37 seal was developed especially for use with SAE flanges. These special seals guarantee high stability of form. Compared to standard O-Rings, their mechanical properties prevent gap extrusion, even when the flanges "breathe" under pressure. The special profile of the F37 seal is ideally adapted to higher pressures or unsuitable surface finish of the flanges. As an alternative, connectors can be equipped with bonded seal rings.

#### Flaring Machine (Adjustable)

For smaller tube connecting projects such as the on-site maintenance of, for example, drilling platforms or ships, the Parflange® ECO for processing steel and stainless steel tube is available.

The machine works to the Parflange® process, proven millions of times over, affording maximum mechanical accuracy and reliability. It does not require any complicated programming or operation to manufacture rapidly smaller quantities up to 165 mm outside diameter. The maximum capacity of the

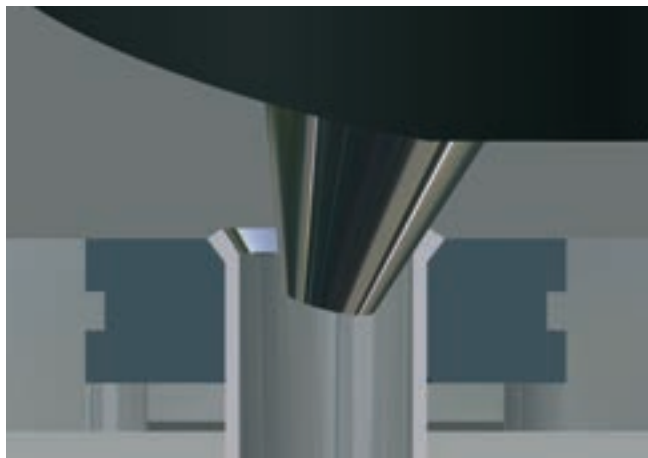

## Parflange® F37 technology

machine is around 5 mm wall thickness for a 165 mm tube at a remarkably short cycle time of 30 to 60 seconds for the flaring and 1 to 2 minutes for the total operation. Other tube diameter allow even thicker tube wall.

### Grooving machine (Retaining Ring connection)

This kind of machine must be utilized for the Retaining Ring system. The compact lathes are clamped on OD of the tube. The tools are rotating around the tube for machining the tube end and outer diameter. Special tool bits and spacers are designed according to retaining ring groove specification from Parker. The portable tool is ideal for workshop use and on-site installation (Tube sizes 1" / 25 mm to 10" / 273 mm).

### Complete range for virtually all diameters

The F37 system complements the EO-2 soft sealing technology for small tube diameters; it also complements the proven Parflange® programme for the SAE product range. It offers the complete range of connectors, flange-to-flange, L- and T-Block connectors, flange-to-port, male and female thread flanges, flange bends, reducer flanges, bulkhead flanges and manifolds on request.



### The F37-Programme – a savings programme

F37 is the way to reduce manufacturing times enormously. By comparing welded connections with Parker flange connector systems, significant opportunities for cost savings become immediately obvious

1. Cutting and deburring tubes
2. Tube preparation for the “connecting process“
3. Welding and/or assembling
4. Inspection (X-ray) of welded connectors
5. Flushing the connected tubes
6. Applying corrosion protection

In comparison with this, weld-free tube forming save time and costs. Expensive cleaning and X-raying of the tube connector become immediately things of the past. The manufacturing time for a tube connector quickly reduces by more than half in comparison with conventional welding. To make this clear, Parker has developed a calculator which, on the basis of the individual input data, determines the exact cost saving from



### Parflange® F37 technology

using Parflange® F37 and/or the high-performance flange connectors. Parker flange connector systems accommodate even higher requirements, especially those from the offshore industry, shipbuilding, heavy machinery construction and press manufacture, as well as from mining, recycling plants and mobile machinery.

#### Personnel and environment-friendly

By comparing the individual operations for a welded line with Parker flanges connected lines, significant cost savings opportunities become immediately obvious. No vapours putting health at risk are released, in contrast to conventional welding processes. Consequently, usage is possible in locations with high requirements such as, for example, offshore oil platforms. In addition to this flaring machine design errors in the preparation of flanges are virtually unknown. Stress corrosion cracking generated during welding operations is history and the life of the finished tubing system is increased. Cold formed Parflange® technologies save power and energy compared to welding and require neither degreasers nor anti-corrosion agents. When galvanized tubes are used, post-galvanization can be omitted because the zinc-coating is not impaired by flaring. Parker flange connector components are delivered in state of the art Cr(VI)-free surfaces.

We deliver all the component parts securely packed to the required location. Reliable delivery on the date advised. And then we come to professional assembly – our specialists will willingly take it on for you. After testing and a trial run, you can press the start button to make your production a success.

#### Principles account for success

The concept of this system is the customer interaction with advice, design, preassembly (with fittings, flanges and machined tubes), delivery and installation as a complete package cannot be beaten. Supportive planning, high-quality products and safe working processes offer the ultimate synergy in time and cost saving. And of course, individual Piping Solutions principles are also available to you.

#### The Parker Piping Solutions concept principles:

|                     |   |
|---------------------|---|
| <b>Advise</b>       | <b>Briefing/<br/>Design discussion</b>  |
| <b>Design</b>       | <b>Tubing layout<br/>Tube dimensioning<br/>Drawings<br/>Documentation</b>                               |
| <b>Pre-assemble</b> | <b>Tube bending<br/>Flaring<br/>Tube cleaning</b>   |
| <b>Deliver</b>      | <b>Assemble/dispatch<br/>Documentation</b>  |
| <b>Install</b>      | <b>Manufacturing<br/>On site management<br/>On site assembly<br/>Inspect and wash<br/>Documentation</b> |

| Feature                              | Customer Value  |
|--------------------------------------|---|
| No welding                           | - Reduced preparation time per joint<br>- No costly inspection of welds (X-ray)   |
| No post-weld cleaning                | - No acid cleaning costs<br>- No waste cleaning costs<br>- No safety risk<br>- Environmentally friendly   |
| No welding stress corrosion possible | - Maximum piping lifetime<br>- Reduced maintenance costs  |
| No „hot work“ permit required        | - Operation can take place in areas with fire risk without interruption of production<br>- Reduced downtime costs<br>- Higher level of safety   |
| Work shop prefabrication             | - High quality joints with better accuracy due to workshop conditions<br>- Minimized need for on-site work<br>- Shorter installation time<br>- Shorter maintenance/downtime<br>- Shorter total project time |
| Cleanliness                          | - Minimized need for repair and replacement of hydraulic system components such as pumps, cylinders,...<br>- Reduced overall flushing time and costs  |
| Easy dismantling and reassembling    | - Quicker, easier and more flexible installation<br>- Reduced downtime costs for maintenance and repair   |





## Connection technology

The Parflange® F37 Programme consists of two flange connection technologies:  
The 37° Flare Flange Connection and the Retaining Ring Connection.

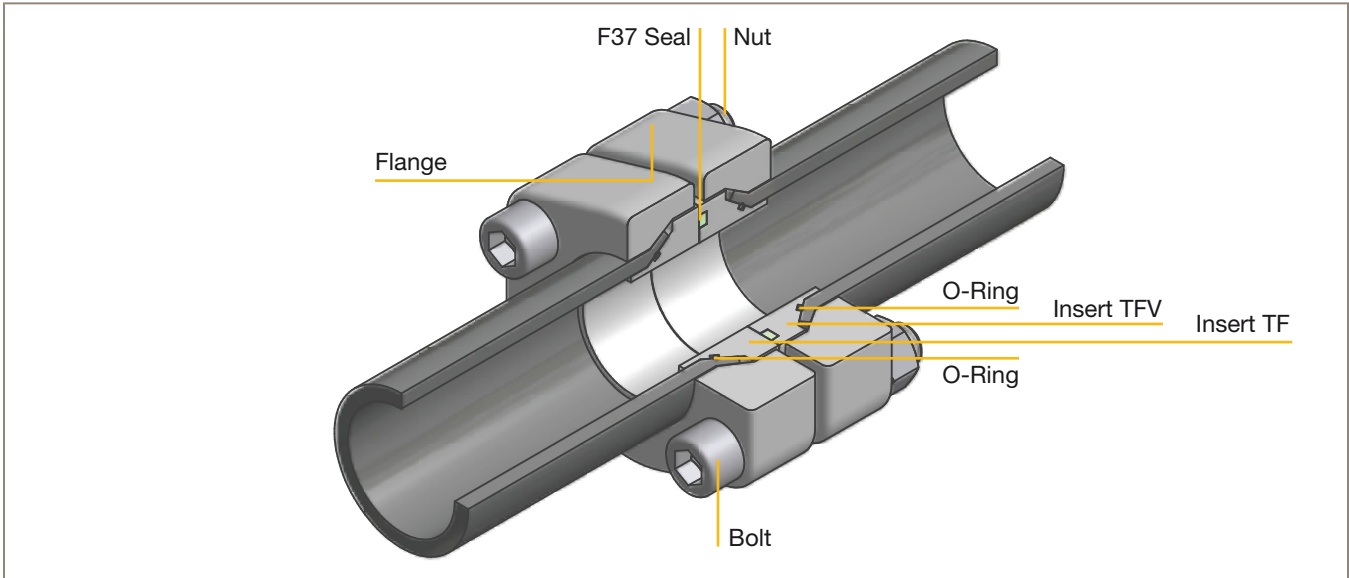

**Parflange® F37 Flare Flanges** - In this configuration, the deburred tube end is flared orbitally to 37° by Parflange® technology. An insert, soft sealed by an O-Ring, is located into each pipe end. In between a F37 Seal (optionally Bonded Seal or O-Ring) is placed. By tightening the flanges together, a soft sealed, high pressure tube connection is made. Available as tube-to-tube connection or tube-to-port connection.

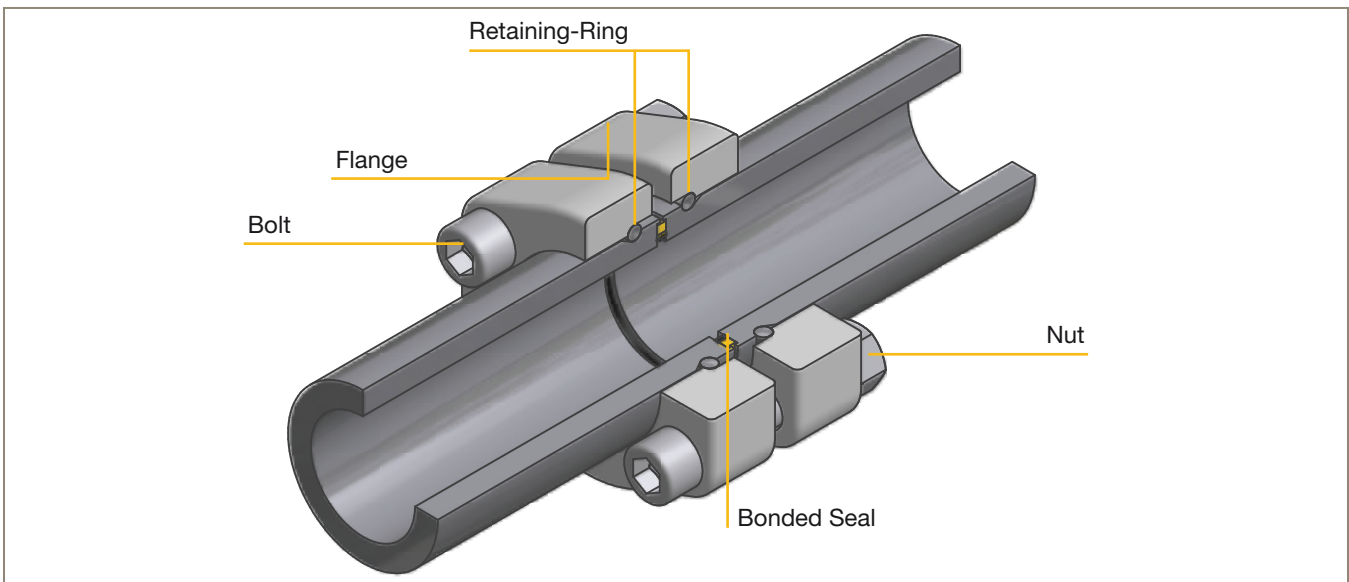

**Retaining Ring Connection** - The retaining ring used in this connection is a stainless steel segmented ring covered by a stainless steel spring. It is assembled in a machined groove on the tube end or adapter. When tightening this system, the flange is pushed against the retaining ring, thus giving a form tight connection. Retaining ring connections complete the Parflange® F37 range with bulkhead, male, female, weld and tube bend connections.

Connection methods F37 – Flared tube

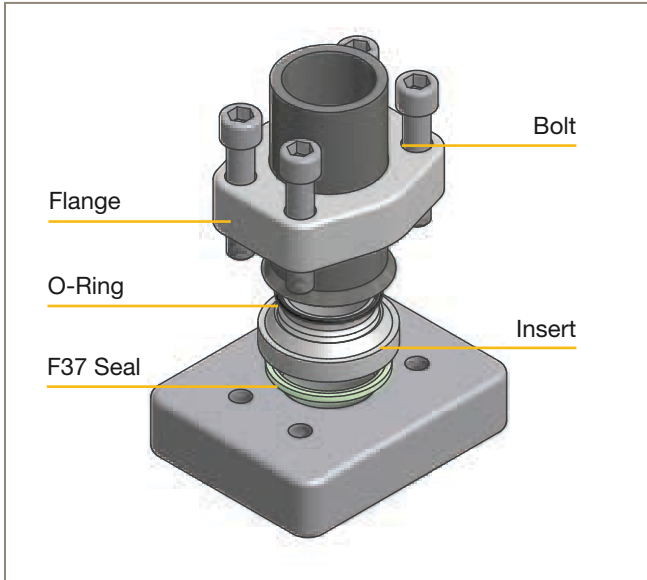

**Flange to Port** – the flanged tube is connected by the flange, insert and F37 seal to a port. Inserts with Bonded Seal can be used alternatively.

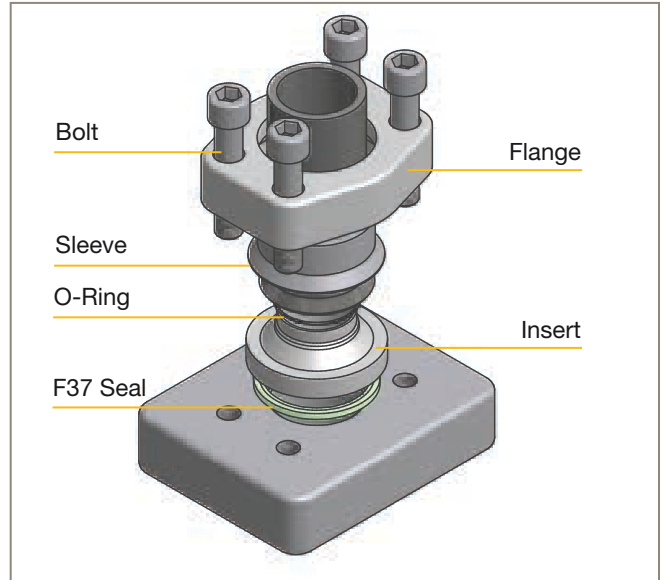

**Flange to Port** – the standard F37 Flanges can be used with adapter sleeve for smaller tube sizes as well.

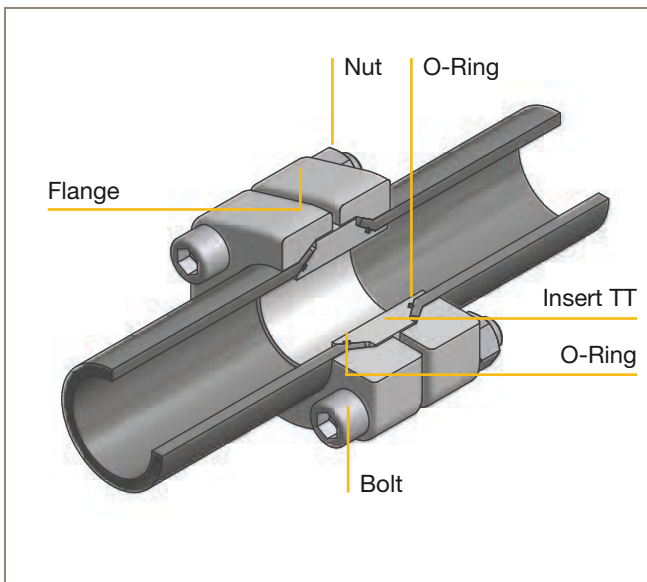

**Tube to Tube** – two flanges and one insert connecting two flared tubes. A two insert solution with F37 Seal or Bonded Seal is optional.

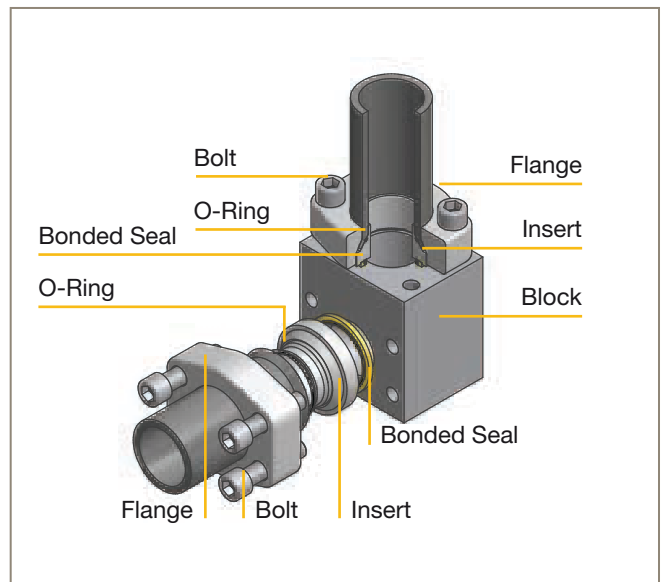

**Tube to Block** – instead of using flange bends compact L-Blocks are available. The range is completed by T-Blocks and Reducing Blocks. Special Manifolds according to customer design available on request.

## Connection methods – Retaining ring

The Retaining Ring Flanges are – like the flanges for the F37 range – according to ISO 6162-1/2 and ISO 6164 footprint. Therefore any combination of the systems is possible.

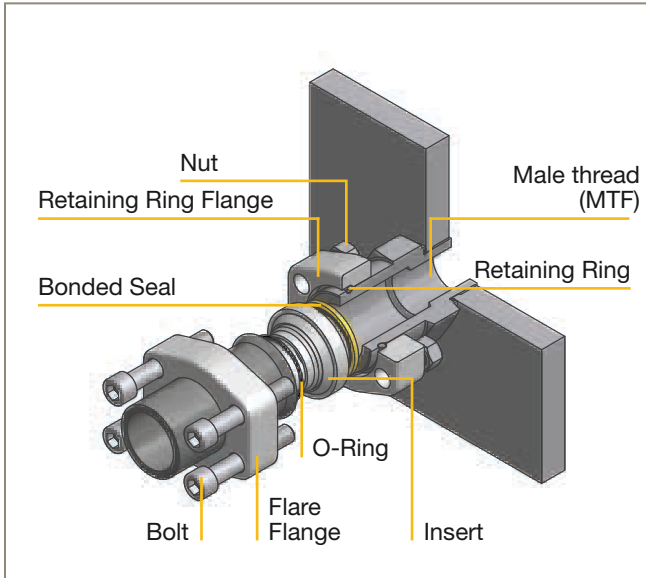

**Male Thread Connection** – Male Stud ends are delivered with soft seal ED end on one side and the Retaining Ring connection on the other side.

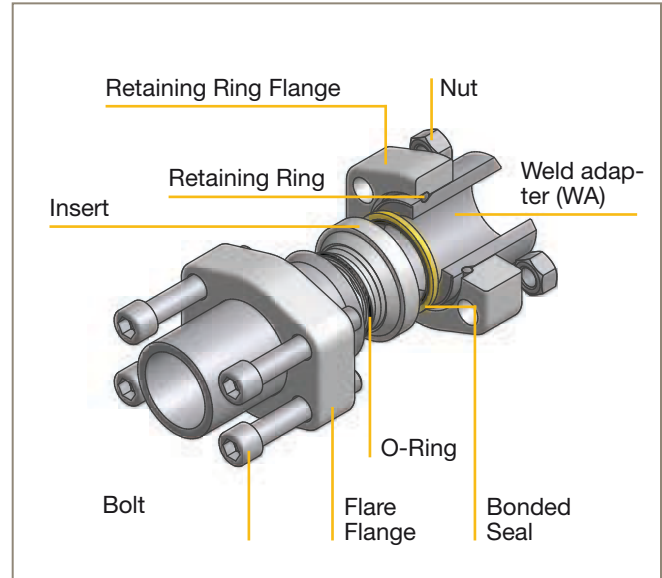

**Weld Adapter** – Weld adapters are delivered with weld end on one side and the Retaining Ring connection on the other side.



# Complete Piping Solutions

Homogeneous solutions offer efficiency

### From Components to full service.

Parker offers you the competent complete solution for hydraulic systems. From advice via design and pre-configuring to delivery and installation - everything with the best quality and reliability. You only have one contact. You take the pressure off your own team, release capacity and overall save a lot of time. You achieve new efficiency at high pressure.

### Excellent complete solution.

Complete Piping Solutions from Parker are always to the customer's advantage. Equally high quality in all areas and available around the world.

The complete solution from a single source frees up customer capacity and lowers the need for customers to provide coordination effort. As a supplier of piping system solutions we offer our customers significant added value.

## Advantages that pay off.

- High-quality system technology
- Saves time
- Saves money
- Customised user solutions
- Environmentally friendly
- Global supply
- Integration into existing systems

|                |   |
|----------------|---|
| Advice         | Briefing/design meeting   |
| Design         | Pipe layout<br>Pipe dimensioning<br>Drawings<br>Documentation               |
| Prefabrication | Pipe bending<br>Pipe end processing<br>Pipe cleaning                        |
| Delivery       | Assembly/<br>Dispatch<br>Documentation                                      |
| Assembly       | On-site advice<br>On-site assembly<br>Testing and flushing<br>Documentation |



Pipe bending

# Complete Piping Solutions

The complete solution for hydraulic systems

The Parker Complete Piping Solutions concept can be used in the most varied and demanding applications. These include shipbuilding, the oil industry, steel plants and other industrial applications. Parker piping solutions offer you the competent complete solution for hydraulic systems.

Starting with the design via pre-configuring to delivery and installation, everything produced by Parker is top quality and extremely reliable. Even at an early stage of designing machines and systems, Parker engineers and technicians are available to you to provide ideal assistance for the development of hydraulic line systems.



The support offered to you by Parker includes a suggestion for the type of connection (product to be used) and the choice of materials to be deployed starting with the lines and even the seals. The manufacture of special components, e.g. blocks or manifolds, is no problem for Parker.

If you have no opportunity for line configuration and assembly Parker is there and able to provide advice with its Complete Piping Solutions concept. It is completely irrelevant whether this is an initial fitting or modernising a machine or equipment. Parker's service covers measuring, preparing the pipeline flange connections, including the pipe flanges and assembling the connections.

Such customised mechanical hydraulic connections offer massive time savings during conversion, expansion or disassembly.



Machine preparation for the bending process



Delivery of components in secure packaging

ENGINEERING YOUR SUCCESS.

# Our customer solutions

Achieving more together

Parker is highly successful with its weld-free piping systems for many applications.



In the Offshoremarket these are pipes for such different ship types as suction dredgers, work ships to install and supply oil platforms, ferries and installation ships for the wind industry. The most varied of hydraulic systems can be given Parflange F37 connections. Piping solutions are also created for drilling and transport towers, crane systems and hoists using Parker's weld-free systems.

It is always about fast, low-cost completion and installation. Weld-free systems enable customers to respond quickly and efficiently to new projects and generate new business. The hydraulic systems in plant and mechanical engineering are also equipped with the Parflange® F37 system. These are the hydraulic, cooling system and return lines.

Customers often have to fight against long manufacturing lead times for a new machine.

If for instance a main ring line for a cooling system needs to be welded, time passes before the final installation on the machine can take place. This is the result of such matters as the set-up and cleaning times for the pipe.

Other applications include renewable energy industries (wind power, water power). Also vehicle construction (car, truck test stands) and general mechanical engineering (wood processing machines, press construction, waste processing).

Precision and flexibility are essential for all applications. Orientable flanges give the pipe fitter greater flexibility during assembly.

The Parflange® F37 machine (WCM-WorkCentre Model) offered by Parker gives the customer a high level of flexibility for on-site assembly.

In summary, the weld-free connection systems from Parker achieve a high level of financial and time savings, flexibility, precision, quality and reliability. And this is associated with extraordinary customer and delivery service.





# Centrally located at the heart of Europe

Complete Piping Solutions Centre in Augustdorf



As a result of the global piping strategy introduced by Parker Hannifin some time ago, there is now also a German piping centre close to Bielefeld (in Augustdorf). The German CPS (Complete Piping Solutions) has a strategic location close to the Parker factory at Bielefeld-Windelsbleiche and the European Distribution Center (EDC). The CPS Germany offers comprehensive options for customer-specific piping system solutions. Piping

system solutions are developed in line with customer requirements and requests, in the newly designed office areas with modern IT equipment. The complete production process is characterised by optimised routes for materials ordering, manufacturing and then dispatch. The flow of goods has been copied from the existing piping centres and the associated positive experience gained.



Locations of the global Parker Piping Solutions Centres



The functional workshop can process pipes with external diameters up to 220 mm on the modern CNC bending machines. These machines can also realise 2xD to 3XD bending radii which are defined as standard for the relevant pipe diameters. The other machines also match the high quality standard used by Parker.

ENGINEERING YOUR SUCCESS.

# The requirements increase

So does our performance

In order to comply with the market and customer requirements in this segment we have aligned our performance to this. The following overview aims to emphasise the range of services offered by CPS Germany.

### Development and design:

- Modern CAD systems can process all common 3D and 2D data formats and simulate installation situations
- The projects are produced as required by or in cooperation with the customer. These may be new systems or upgrades
- It may require taking pipe measurements on-site using a modern measurement system. These data can be handed over to the CAD System
- Data from the measurement system are used later for quality control in order to ensure an ideal and secure production process

### Cold bending:

- After creating the data required for production these are transferred to the machines. The available bending machines process tubes with diameters from 6 x 1 mm to 190 x 20 mm (thin-walled Ø 220 x 6 mm)

### Tube end processing:

- Modern CNC controlled machines are available for processing pipe ends. Tube end processing is carried out based on internal standards

### Tube cleaning:

- Tube cleaning using the ISO 4406 / NAS 1638 standard
- Permanent control of the pollution and cleanliness level with modern measuring devices

### Pressure test:

- Pressure test to customer specifications possible
- Documentation at the customer's request



### Installation / support:

- Delivery of pre-configured tube systems to the customer's desired address
- Installation of tube systems whilst taking into account the parameters and work steps set in the installation manual
- Installation by end customer training conducted by Parker



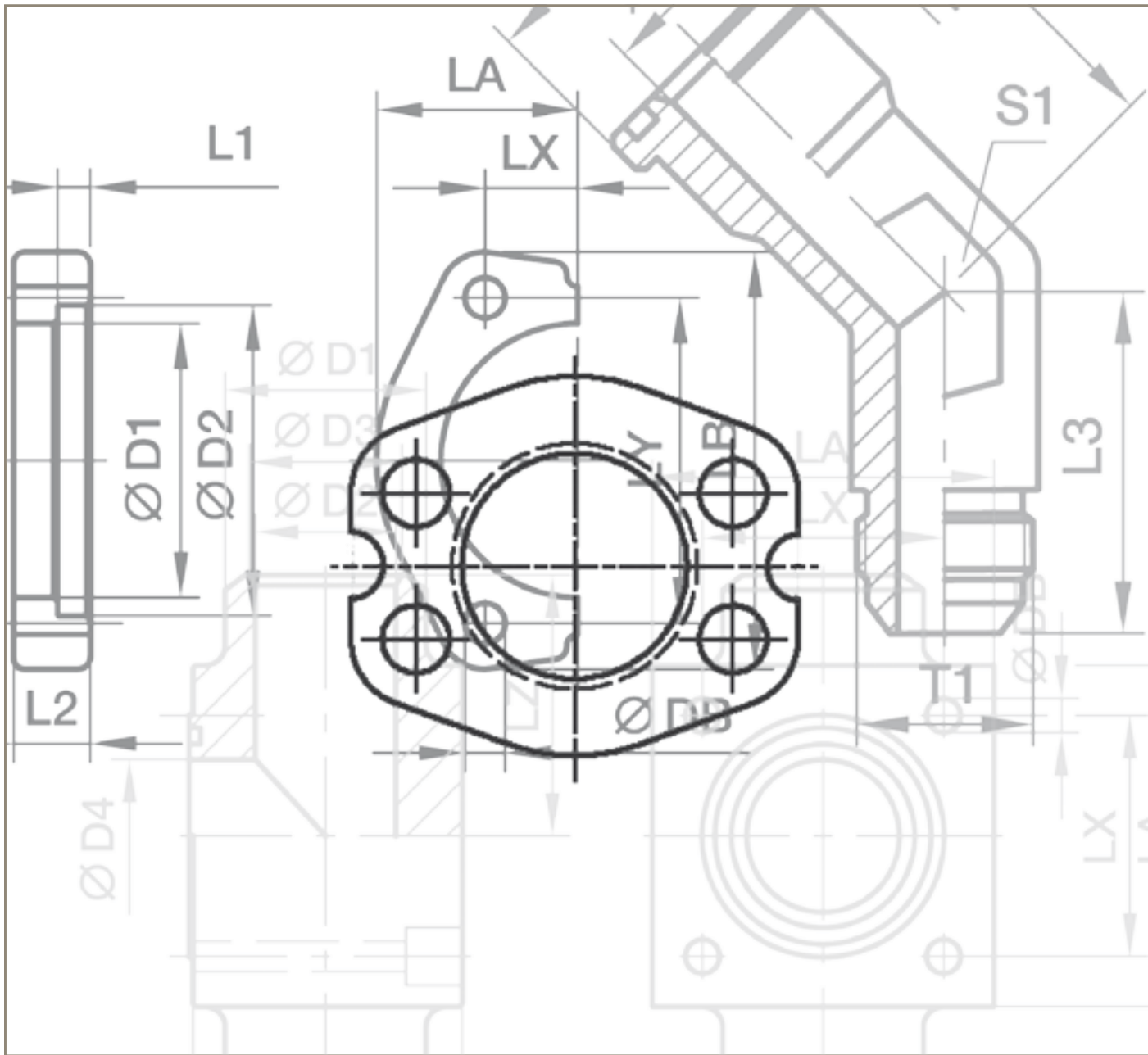

## Technical data

ENGINEERING YOUR SUCCESS.



## Technical data

### Pressure reductions and temperatures

Required pressure reductions (depending on the material) with reference to the catalogue pressures for higher temperatures. Both metal fitting material and elastomeric sealing compound have to be selected according to the temperature range of the system.

**DNV may require different pressure reduction based on application**

| Material                             | Pressure reduction of permissible operating temperatures TB in °C |     |      |     |     |      |       |       |      |      |      |      |      |      |      |
|--------------------------------------|---|-----|------|-----|-----|------|-------|-------|------|------|------|------|------|------|------|
|                                      | -60   | -54 | -40  | -35 | -25 | +20  | +50   | +100  | +120 | +150 | +175 | +200 | +250 | +300 | +400 |
| Steel                                |   |     | -10% |     |     | 0%   |       |       |      | 11%  | 19%  |      |      |      |      |
| Steel, tubes                         |   |     | -10% |     |     | 0%   |       |       |      | 19%  |      | 27%  |      |      |      |
| Stainless steel                      | 0%  |     |      |     |     | 5%   | 15%   | 23%   |      | 29%  |      | 33%  | 37%  | 42%  |      |
| Stainless steel, tubes               | 0%  |     |      |     |     | 5.5% | 11.5% | 21.5% |      |      | 29%  |      | 34%  |      |      |
| Sealing material NBR (e.g. Perbunan) |   |     |      |     |     |      |       |       |      |      |      |      |      |      |      |
| Sealing material FKM                 |   |     |      |     |     |      |       |       |      |      |      |      |      |      |      |
| Sealing material Polyurethan (P5008) |   |     |      |     |     |      |       |       |      |      |      |      |      |      |      |

|   |   |
|---|---|
|  | Permissible operating temperature                           |
|  | Ambient temperature of hydraulic and pneumatic applications |
|  | Temperature not permissible                                 |

Calculation example:

Temperature = 200°C

Material = Stainless steel

Pressure reduction = 29%

Pressure reduction tubes = 21.5%

PN tube 16x2.5/71. DIN2413 III = 362 bar

Formula:

$$PN_{200^{\circ}\text{C}} = \frac{400 \text{ bar}}{100\%} \times (100\% - 29\%) = 284 \text{ bar}$$

$$PN_{\text{tube } 200^{\circ}\text{C}} = \frac{362 \text{ bar}}{100\%} \times (100\% - 21.5\%) = 284 \text{ bar}$$

### F37 seal

The F37 seal was developed especially for use with SAE flanges. Compared to a standard O-Ring the special profile of the F37 seal is ideally adapted to higher pressures and flange surface finish.

The particularly low compression set of the polyurethane compound ensures dimensional stability of the seal over a large temperature range. Its high extrusion resistance prevents gap extrusion even if the flanges "breathe" under pressure. Due to

good abrasion resistance, less preparation is necessary on the surface finish of the sealing area of the flange. The frequently occurring "pumping" phenomenon of O-Rings is prevented by the shape of the F37 seal.

#### Application area

Static sealing for SAE-Flanges

Working pressure: ≤ 600 bar

Working temperature: see table above

#### Materials

The F37 seal is made of a polyurethane based Parker compound with a hardness of approx. 93 Shore A. In comparison with other polyurethane materials currently available on the market, it excels because of its increased heat resistance, improved performance against hydrolysis and low compression values.

**For special requirements (pressure, temperature, speed, application in water, HFA-, HFB-fluids etc.), please contact our Consultancy Service, so that suitable materials and/or designs can be recommended.**

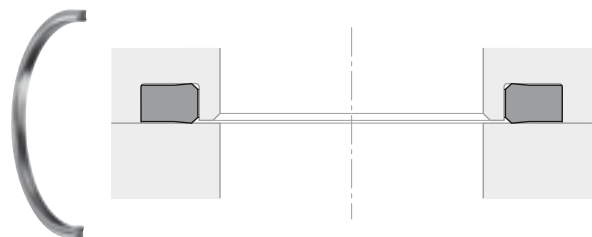



## Tolerances and standards

| Threads          |               |                  |
|------------------|---------------|------------------|
| Outside diameter | Core diameter | Type of thread   |
| 8.00             | 6.92          | M 8x1            |
| 9.73             | 8.57          | R 1/8"x28        |
| 10.00            | 8.92          | M 10x1           |
| 10.27            | 8.77          | NPTF 1/8"x27     |
| 11.11            | 9.74          | JIC 7/16"x20     |
| 12.00            | 10.38         | M 12x1.5         |
| 12.70            | 11.33         | JIC 1/2"x20      |
| 13.16            | 11.45         | R 1/4"x19        |
| 13.57            | 11.31         | NPTF 1/4"x18     |
| 14.00            | 12.38         | M 14x1.5         |
| 14.27            | 12.76         | JIC 9/16"x18     |
| 15.88            | 14.35         | SAE 5/8"x18      |
| 16.00            | 14.38         | M 16x1.5         |
| 16.66            | 14.95         | R 3/8"x19        |
| 17.06            | 14.80         | NPTF 3/8"x18     |
| 18.00            | 16.38         | M 15x1.5         |
| 19.05            | 17.33         | JIC 1/4"x16      |
| 20.00            | 18.38         | M 20x1.5         |
| 20.96            | 18.63         | R 1/2"x14        |
| 21.22            | 18.32         | NPTF 1/2"x14     |
| 22.00            | 20.38         | M 22x1.5         |
| 22.23            | 20.26         | JIC 7/8"x14      |
| 22.91            | 20.59         | R 5/8"x14        |
| 24.00            | 22.38         | M 24x1.5         |
| 26.00            | 24.38         | M 26x1.5         |
| 26.44            | 24.12         | R 3/4"x14        |
| 26.57            | 23.67         | NPTF 3/4"x14     |
| 26.99            | 25.10         | JIC 1 1/16"x12   |
| 28.00            | 26.38         | M 28x1.5         |
| 30.00            | 27.83         | M 30x2           |
| 30.16            | 28.20         | JIC 1 3/16"x12   |
| 30.20            | 27.88         | R 7/8"x14        |
| 31.23            | 29.61         | NPTF 1"x11.5     |
| 33.25            | 30.29         | R 1"x11          |
| 33.34            | 31.40         | JIC 1 5/16"x12   |
| 36.00            | 33.83         | M 36x2           |
| 41.28            | 39.30         | JIC 1 5/8"x12    |
| 41.91            | 38.95         | R 1 1/4"x11.5    |
| 41.99            | 38.95         | NPTF 1 1/4"x11.5 |
| 42.00            | 39.83         | M 42x2           |
| 45.00            | 42.83         | M 45x2           |
| 47.63            | 45.80         | JIC 1 7/8"x12    |
| 47.80            | 44.85         | R 1 1/2"x11      |
| 48.05            | 44.52         | NPTF 1 1/2"x11.5 |
| 52.00            | 49.83         | M 52x2           |
| 59.61            | 56.66         | R 2"x11          |
| 60.09            | 56.56         | NPTF 2"x11.5     |
| 60.20            | 60.80         | JIC 2 1/2"x12    |
| 65.71            | 62.75         | R 2 1/4"x11      |
| 73.00            | 68.80         | NPTF 2 1/2"x8    |
| 75.18            | 72.23         | R 2 1/2"x11      |
| 87.88            | 84.93         | R 3"x11          |
| 89.00            | 85.00         | NPTF 3"x8        |
| 113.03           | 110.07        | R 4"x11          |
| 114.35           | 110.30        | NPTF 4"x8        |

**NOTE:** NPTF thread have to be measured outside on the 4. thread from the end

|            |   |
|------------|---|
| A.P.I.     | American Petroleum Institute Taper Thread           |
| A.S.A.E.   | American Society of Agricultural Engineers          |
| A.S.S.P.T. | American National Straight Pipe Thread              |
| B.S.P.     | British Standard Parallel Pipe Thread               |
| B.S.T.P.   | British Standard Taper Pipe Thread                  |
| F.I.E.I.   | Farm and Industrial Equipment Institute             |
| G.H.T.     | Garden Hose Threads/F.P.T.- Female Pipe Thread      |
| I.P.T.     | American Iron Pipe Thread - Straight                |
| J.I.C.     | Joint Industry Conference (SAE 37)                  |
| J.I.S.     | Japanese Industrial Standard                        |
| M.         | Metric Thread                                       |
| M.M.       | Metric Thread                                       |
| N.P.S.     | American National Pipe Thread - Straight            |
| N.P.S.M.   | American National Pipe Thread - Straight Mechanical |
| N.P.T.     | American National Pipe Thread - Taper               |
| N.P.T.F.   | American National Pipe Thread - Taper/Dry seal      |
| N.S.T.     | American National Standard Thread - Straight        |
| R.         | Rörgjenger - BSP                                    |
| R.T.       | British Round Thread                                |
| S.A.E.     | Society of Automative Engineers (45)                |
| U.R.T.     | Dennis Urban Round Thread                           |
| U.N.C.     | Unified Coarse Thread                               |
| U.N.F.     | Unified Fine Thread                                 |
| VEE        | Shelvoke Drewry "VEE" Round Thread                  |
| W.         | Withworth Thread                                    |





# Installation F37 Flange system

Current installation guide:

- [www.parker.com](http://www.parker.com) ▾
- Division/Brand ▾
- Tube Fittings Division Europe ▾
- Literature ▾
- Service Manuals/User Guides ▾
- Flanges





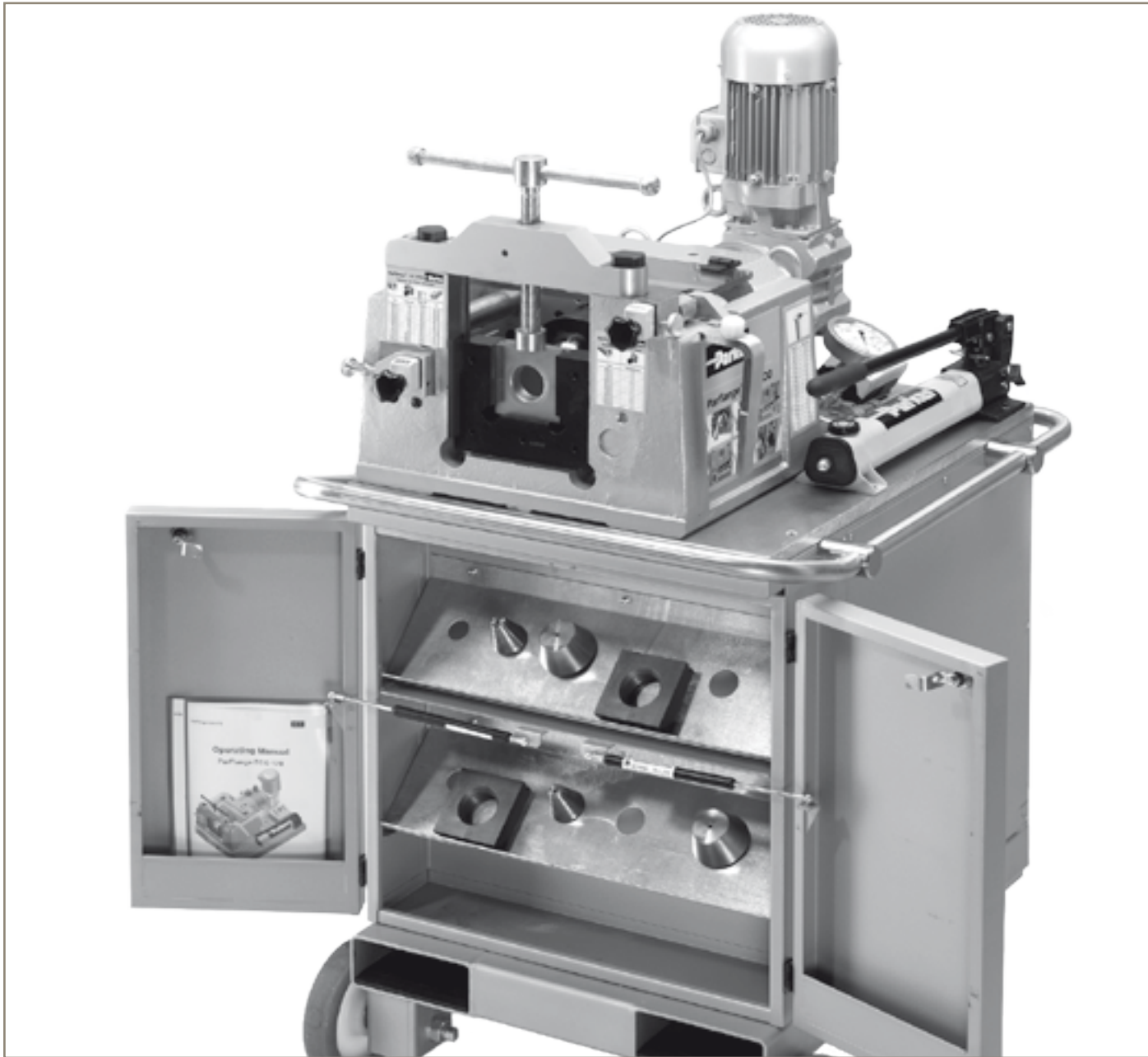

## Machines, tooling and equipment

ENGINEERING YOUR SUCCESS.

### Parflange® 170

Workshop machine for F37 flange connections

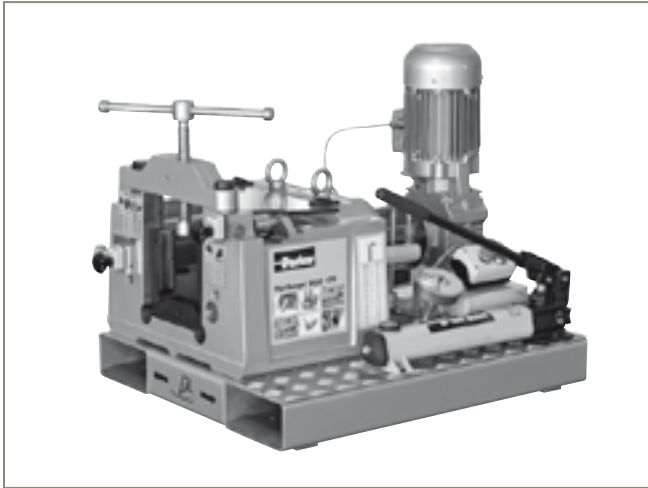

Parflange® 170 ECO for workbench

The Parflange® 170 ECO is a compact workshop machine for 37° flaring of tubes for flange connections.

The orbital tube flaring is achieved by a rotating flaring unit, powered by an electro-mechanical drive. Two hydraulic cylinders operated by a hand pump generate the axial feed movement. Gas springs move the flaring unit back after the valve on the hand pump is opened. The tubes are mechanically clamped between a set of dies. The machine features an adjustable tube stop for tube positioning (Tube Stop), and an adjustable stop for the tube depth to be flared (Spindle Stop).

The machine is used to form tube ends by means of a rotational action. It is designed as a workshop machine for installations of tube connections.

**The machine is available in 2 versions:**

- Parflange® 170 ECO for use on work bench and
- WorkCenter Parflange® 170 WCM which is mounted on a movable tool cabinet

Parflange® machines are delivered ready for use. Tools have to be ordered separately. Clamping die sets and flanging pins are available for common tube sizes. The machine can be moved by crane or forklift.

**Applications**

- The F37 system is an alternative to conventional welding of flanges in shipbuilding, oil & gas exploration and similar industries
- Workshop use, project work, plant maintenance, on-site assembly
- Not recommended for mass production



Parflange® 170 WCM WorkCenter

**Specifications**

|                                |   |
|--------------------------------|---|
| Purpose                        | 37° flaring for Parker F37 flange connection  |
| Process                        | Tube forming by orbital flaring process   |
| Design                         | On-site and workshop machine for individual tube manufacturing                                    |
| Models                         | Parflange® 170 ECO for workbench use<br>WorkCenter Parflange® 170 WCM                             |
| Operation                      | Manual tube clamping<br>Electrically driven flaring unit<br>Manual feed by hand-pump              |
| Tube diameter                  | 16 mm – 168.3 mm O.D.   |
| Maximum capacity               | 168.3 x 2.77 mm   |
| Tube material                  | Steel and stainless steel   |
| Cycle time                     | 1 – 2 minutes flaring time<br>3 – 5 minutes total cycle time                                      |
| Economic production quantity   | Up to 50 assemblies per day   |
| Tools                          | Flanging pin BF37...<br>Clamping die set MF37...<br>Die frames required for small to medium sizes |
| Tool lubrication               | manual  |
| Forming lubricant for pin      | LUBSS   |
| Machine dimensions (L x W x H) | Parflange® 170 ECO:<br>850 x 680 x 675 mm<br>Parflange® 170 WCM:<br>880 x 810 x 1470 mm           |
| Weight                         | Parflange® 170 ECO: approx. 350 kg<br>Parflange® 170 WCM: approx. 460 kg                          |
| Nominal voltage                | 400 V/3Ph/50 Hz/3A/1.1 KW   |
| Connecting cable               | 3m/CEE 16A  |
| Sound pressure level           | Less than 70 dB (A)   |

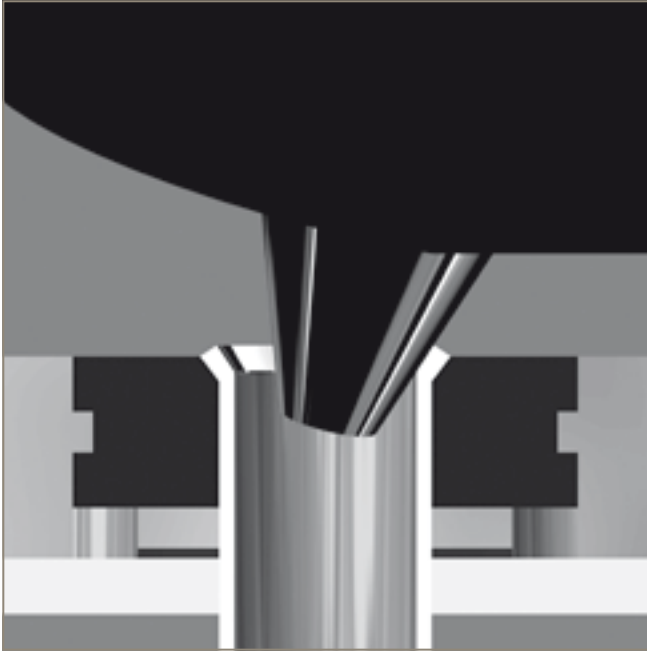

Superior sealing surface is achieved by orbital flaring

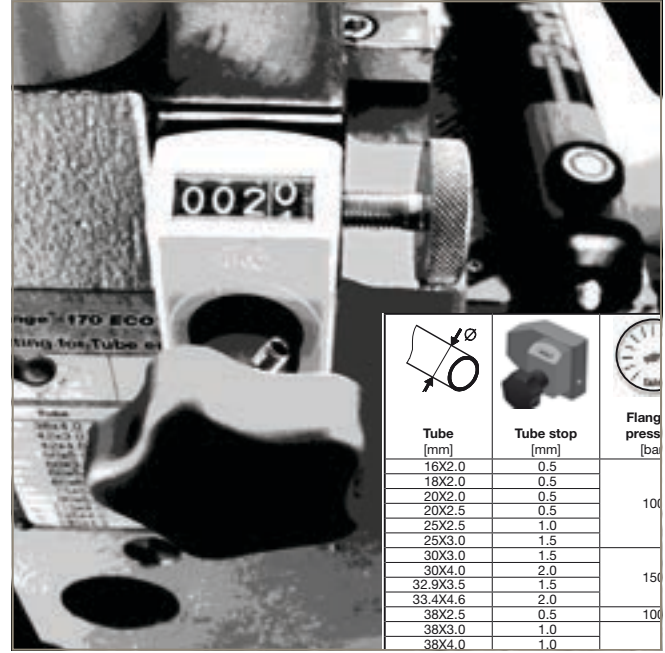

Consistent flaring result is achieved by setting of Tube Stop and Spindle Stop

### Features, advantages and benefits of Parflange® 170 ECO

- Cost saving** – Compared to welding or brazing, orbital flaring is much less time consuming. Special tube preparation and finishing are not necessary. Flaring uses only a fraction of the energy needed for brazing or welding.
- Zinc plated tubing** – The Parflange® process allows the use of zinc plated tubing. The cost for cleaning, post process plating or painting is saved.
- Superior sealing performance** – The orbital flaring process achieves a sealing surface of superior surface quality and mechanical strength.
- Process/Product concept** – Parflange® machines are especially designed to match Parker F37 flange standards. Machines, tools and products are fine-tuned for reliable performance.
- Workshop use** – The rigid machine design allows project work in on site piping workshops.
- Short clamping length** – Clamping dies for 37° flaring are optimized for minimum straight tube length.
- Easy to use** – All operational devices are obvious so that machine operation is intuitive.
- Quality** – Consistent quality results are achieved by recommended values for machine setting.
- Constant flare diameter** – The diameter of the 37° flare is given by the tool contour and the Tube Stop adjustment. A chart on the machine indicates recommended Tube Stop setting.
- Prevention of over-flaring** – The shape of the 37° flare is given by the tool contour and the Spindle Stop adjustment. This prevents difficulties to fit the insert into the flare.
- Flexible** – Different tube material and quality might require special setting of Tube Stop, Spindle Stop, flanging feed and flanging force. For best results, these parameters can be manually adjusted based on operators experience.
- Clean** – The Parflange® process is environmentally clean and safe. As no heat or chemicals are used, hazards from fumes or heat do not occur.
- Perfect for on site work** – The machine has special attachments for transportation by fork lift and crane. The wide base provides a safe stand. This is particularly useful for on site pipe installation in shipyards or in oil and gas exploration.
- Ready to go** – The Parflange® 170 ECO is delivered including all necessary details like electrical plug, operator manual, declaration of CE-conformity, short instruction pictograms on machine housing and dimensional charts for tube preparation.
- Parflange® 170 WCM** – This model is mounted on a robust tool cabinet with wheels. It is easy to move and perfect for flexible workshop use.

## Tool selection

### Workshop machine for F37 flange connections

#### Ordering

| Type  | Order code                        |
|---|-----------------------------------|
| Parflange® 170 Basic machine<br>Ready to use, including operation manual, filled with hydraulic oil, without tools<br>Basic machine for workbench use, 400V, 50Hz<br>WorkCenter with tool cabinet, 400V, 50Hz | 170EU400VECO<br>170EU400VWCM      |
| Promotion leaflet 4162/UK   | via Parker catalogue service EMDC |
| Operating manual UK/DE/FR/IT/ES   | 170/MANUAL                        |
| Tool lubricant qty: 1 L   | LUBSS                             |

Parflange® machines are shipped in special containers which should be kept for future transportation to avoid damage.

| Clamping die frame<br>small/large |                                  | Clamping die set "MF"          | Extended clamping die set "MF"<br>for large tube wall thickness | Flanging pin "BF"               |              |
|-----------------------------------|----------------------------------|--------------------------------|---|---------------------------------|--------------|
| Tube O.D.<br>mm                   | Order code<br>Clamping die frame | Order code<br>Clamping die set | Order code<br>Extended clamping die set                         | Order code<br>Flanging pin      |              |
| 16.0                              | MF37/F20-60                      | MF37-16                        |   | BF37-6/42                       |              |
| 20.0                              |                                  | MF37-20                        |   | BF37-6/42                       |              |
| 25.0                              |                                  | MF37-25                        |   | BF37-6/42                       |              |
| 30.0                              |                                  | MF37-30                        |   | BF37-6/42                       |              |
| 32.9                              |                                  | MF37-32.9                      |   | BF37-6/42                       |              |
| 33.4                              |                                  | MF37-33.4                      |   | BF37-6/42                       |              |
| 38.0                              |                                  | MF37-38                        |   | BF37-38/60                      |              |
| 42.0                              |                                  | MF37-42                        |   | BF37-38/60                      |              |
| 48.3                              |                                  | MF37-48.3                      |   | BF37-38/60                      |              |
| 50.0                              |                                  | MF37-50                        |   | BF37-38/60                      |              |
| 60.0                              | MF37/F73-90                      | MF37-60                        |   | BF37-60/75                      |              |
| 60.3                              |                                  | MF37-60.3                      |   | BF37-60/75                      |              |
| 65.0                              |                                  | MF37-65 E                      |   | BF37-60/75                      |              |
| 73.0                              |                                  | MF37-73                        | MF37-73E for Tube 73X7  | BF37-60/75                      |              |
| 75.0                              |                                  | MF37-75                        |   | BF37-75/90                      |              |
| 88.9                              |                                  | MF37-88.9                      |   | BF37-75/90                      |              |
| 90.0                              |                                  | MF37-90                        | MF37-90E for Tube 90X9  | BF37-75/90*                     |              |
| 100.0                             |                                  | no frame required              | MF37-100  |                                 | BF37-100     |
| 114.3                             |                                  |                                | MF37-114.3  | MF37-114.3E for Tube 114.3X6.02 | BF37-115/140 |
| 115.0                             |                                  |                                | MF37-115  |                                 | BF37-115/140 |
| 125.0                             | MF37-125                         |                                |   | BF37-115/140                    |              |
| 139.7                             | MF37-139.7                       |                                |   | BF37-115/140                    |              |
| 140.0                             | MF37-140                         |                                |   | BF37-115/140                    |              |
| 141.3                             | MF37-141.3                       |                                |   | BF37-141/165                    |              |
| 165.0                             | MF37-165                         |                                |   | BF37-141/165                    |              |
| 168.3                             | MF37-168.3                       |                                | BF37-141/165  |                                 |              |

tools for scheduled pipes on request

\* for the first flaring step, tool BF37-90PREFLARE necessary

#### Tool lifetime

Assembly tools are subject of wear and must be regularly cleaned and checked.

Worn out tools can cause dangerous assembly failures and must be replaced in time.

Maximum lifetime can be achieved by following factors:

- Regular cleaning and checking
- Clean and corrosion-protected storage
- Proper de-burring and cleaning of tube end
- Proper tool selection and operation
- Use of specified lubricant





## Assembly machines



EO-KARRYMAT

### EO-KARRYMAT

The EO-KARRYMAT is a simple, portable device for assembly of EO Progressive Ring and EO-2 tube fittings.

The EO-KARRYMAT consists of a hydraulically powered tool and a hand-pump.

The EO-KARRYMAT is ideal for repair work.

- Assembly of: EO2 and EO Progressive Ring
- Tube-OD: 6 – 42 mm
- Total cycle time: 30 – 60 sec.
- Economic production quantity: max. 50 assemblies per day
- Dimensions (L x W x H): 750 x 360 x 260 mm
- Weight: 28 kg
- Power supply: Hand-pump

Catalogue: 4100

Bulletin: 4047



EOMAT ECO

### EOMAT ECO

The EOMAT ECO is a mobile machine for the assembly of EO-2 and EO Progressive Ring fittings. This electro-hydraulic equipment is simple to use, robust and easy to move. The assembly pressure is set on a digital display.

The EOMAT ECO is ideal for hydraulic service and on-site installation.

- Assembly of: EO-2 and EO Progressive Ring
- Tube-OD: 6 – 42 mm
- Total cycle time: 15 – 20 sec.
- Economic production quantity: max. 100 assemblies per day
- Dimensions (L x W x H): 750 x 360 x 300 mm
- Weight: 30 kg
- Power supply: 230 V 1-phase 50 Hz 700 W

Catalogue: 4100

Bulletin: 4046

## Assembly machines



EOMAT UNI

### EOMAT UNI

The EOMAT UNI is a universal workshop machine for the assembly of EO-2 and EO Progressive Ring fittings as well as 37° flaring for Triple-Lok®. Therefore, the machine requires additional bite type or flaring heads. The equipment is very robust and easy to use.

The EOMAT UNI is ideal for workshop use and project work.

- Assembly of: EO-2 and EO Progressive Ring
- 37° Flaring of: Triple-Lok®
- Tube-OD: 6 - 42 mm
- Total cycle time: 12 - 15 sec.
- Economic production quantity: max. 300 assemblies per day
- Dimensions (L x W x H): 535 x 515 x 285 mm
- Weight: 66 kg
- Power supply: 230 V 1-phase 50 Hz 2000 W

Catalogue: 4100

Bulletin: 4042



EO2-FORM F3

### EO2-FORM F3

The EO2-FORM F3 WorkCenter is designed to cold-form hydraulic tubes for EO2-FORM connections. All machine components are integrated into the machine housing, which also provides racks for tool storage. The EO2-FORM F3 represents a complete tube forming WorkCenter.

The WorkCenter EO2-FORM F3 is ideal for workshop use and project work.

- Assembly of: Parker EO2-FORM connections
- Tube-OD: 6 - 42 mm
- Total cycle time: 15 - 20 sec.
- Economic production quantity: max. 100 assemblies per hour
- With oil cooler: max. 200 assemblies per hour
- Dimensions (L x W x H): 650 x 750 x 1200 mm
- Weight: 300 kg
- Power supply: 400 V 3-phase 50 Hz 4 kW

Catalogue: 4100

Assembly machines



**E02-FORM PRO22**

The E02-FORM PRO22 WorkCenter is based on proven EO2FORM technology. It is much faster, allows smaller tube bends, is less noisy compared to the standard EO2-FORM F3 WorkCenter.

The WorkCenter EO2-FORM F3 is ideal for economic mass production of small to medium tube sizes.

- Assembly of: Parker EO2-FORM connections
- Assembly method: Axial forming
- Tube-OD: 6 - 22 mm
- Tube wall thickness: max. 2 mm
- Cycle time: approx. 6 sec.
- Economic production quantity: max. 600 assemblies per hour
- Dimensions ( L x W x H ): 800 x 660 x 1150 mm
- Weight: 475 kg
- Power supply: 400 V 3-phase 50 Hz 4 kW

Catalogue: 4100  
Bulletin: 4032

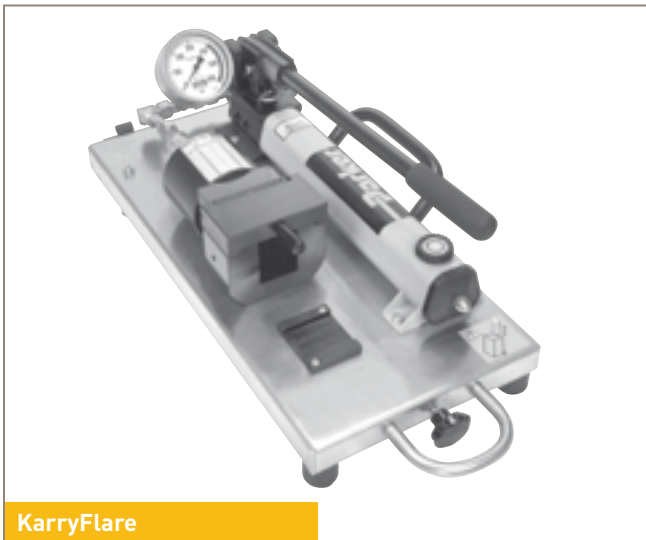

**KarryFlare**

The KarryFlare is a portable device for easy and workmanlike 37° flaring for Triple-Lok® tube connections.

The KarryFlare consists of a hydraulic flaring unit and a hand-pump. It is practical, simple to operate and easy to transport.

The KarryFlare is ideal for repair work.

- 37° flaring for: Triple-Lok®
- Tube-OD: 6 - 42 mm
- Total cycle time: 30 - 60 sec.
- Economic production quantity: max. 50 assemblies per day
- Dimensions ( L x W x H ): 750 x 360 x 260 mm
- Weight: 29 kg
- Power supply: Hand-pump

Catalogue: 4100  
Bulletin: 4047

### Assembly machines



ParFlare ECO

#### ParFlare ECO

The ParFlare ECO is a mobile 37° flaring machine for the assembly of Triple-Lok tube fittings. This electro-hydraulic equipment is simple to use, robust and easy to move. The assembly pressure is set on a digital display.

The ParFlare ECO is ideal for hydraulic service and on-site installation.

- 37° flaring of: Triple-Lok®
- Assembly method: Axial forming
- Tube-OD: 6 – 42 mm
- Total cycle time: 15 – 20 sec.
- Economic production quantity: max. 100 assemblies per day
- Dimensions (L x W x H): 750 x 360 x 300 mm
- Weight: 30 kg
- Power supply: 230 V 1-phase 50 Hz 700 W

Catalogue: 4100

Bulletin: 4048



ParFlare 120 WCM

#### ParFlare 120 HPF

The Parflare 120 WCM is a flaring Work Centre for Parker HPF connections. The tube end is formed in HPF shape by axial pressing. Comfortable operation and adjustable tube stop provide precise and consistent forming result.

The machine is mounted on a robust tool cabinet with wheels. The Parflare 120 WCM represents a complete tube forming WorkCenter. It is easy to move around on wheels, by crane and forklift truck.

The Parflare 120 WCM is ideal for workshop use and on-site installation.

- Tube end forming for: Parker HPF flange connection
- Assembly method: Axial pressing
- Tube-OD: 38 – 90 mm
- Total cycle time: 3 – 5 min.
- Economic production quantity: max. 150 assemblies per day
- Dimensions (L x W x H): 850 x 680 x 675 mm
- Weight: 360 kg
- Power supply: 400 V 3-phase 50 Hz 1,1 kW

Catalogue: 4167

Bulletin: 4169





Parflange® 1025

### Parflange® 1025

The Parflange® 1025 is an orbital 37° flaring and 180° flanging machine. By using the Parflange® process, it achieves an excellent sealing surface and a high-strength tube connection. This electro-hydraulic machine is easy to operate and can be moved around in workshops.

The Parflange® 1025 is ideal for workshop use and project work.

- 180° flanging of: O-Lok®
- 37° flaring of: Triple-Lok®
- Tube-OD: 6 – 25 mm
- Total cycle time: 15 – 20 sec.
- Economic production quantity: max. 100 assemblies per day
- Dimensions (L x W x H): 390 x 670 x 460 mm
- Weight: 60 kg
- Power supply: 230 V 1-phase 50 Hz / 400 V 3-phase 50 Hz

Catalogue: 4100

Bulletin: 4390



Parflange® 50

### Parflange® 50

The Parflange® 50 is an orbital 37° flaring and 180° flanging machine. By using the Parflange® process, it achieves an excellent sealing surface and a high-strength tube connection.

It represents a complete tube forming WorkCenter. For professional mass production of O-Lok® connections, the Parflange® 50 PRO can be ordered with an automatic sleeve feeder.

The Parflange® 50 BASIC is ideal for workshop use and project work, the 50 PRO is ideal for professional mass production.

- 180° flanging of: O-Lok®
- 37° flaring of: Triple-Lok®
- Tube-OD: 6 – 50 mm
- Total cycle time: 15 – 20 sec.
- Economic production quantity: max. 500 assemblies per day
- Quantity with sleeve feeder: max. 1200 assemblies per day
- Dimensions (L x W x H): 700 x 840 x 1035 mm
- Weight: 380 kg
- Power supply: 400 V 3-phase 50 Hz 4,5 kW

Catalogue: 4100

Bulletin: 4391

## Assembly machines



Parflange® 170 ECO

### Parflange® 170 ECO

The Parflange® 170 is a simple flaring machine for Parker F37 connections. By using the Parflange® process, it achieves an excellent sealing surface and a high-strength tube connection.

The equipment is very robust and easy to use. It saves time and effort compared to conventional welding of flange connections.

Parflange® 170 WCM Workcenter is ideal for workshop use. The 170 ECO is ideal for onsite installation.

- 37° flaring of: F37 flange connection
- Tube-OD: 16 - 140 mm
- Total cycle time: 30 - 60 sec.
- Economic production quantity: max. 50 assemblies per day
- Dimensions (L x W x H): ECO: 850 x 680 x 675
- Weight: 360 kg
- Power supply: 400 V 3-phase 50 Hz 1,1 kW

Catalogue: 4100



Parflange® 170 WCM

### Parflange® 170 WCM

The Parflange® 170 WCM is a flaring Work Centre for Parker F37 connections. By using the Parflange process, it achieves an excellent sealing surface and a high-strength tube connection.

The machine is mounted on a robust tool cabinet with wheels. The EO2-FORM F3 represents a complete tube forming WorkCenter.

The Parflange 170 WCM is ideal for workshop use and on-site installation.

- 37° flaring of: F37 flange connection
- Assembly method: Orbital forming
- Tube-OD: 16 - 140 mm
- Total cycle time: 30 - 60 sec.
- Economic production quantity: max. 150 assemblies per day
- Dimensions (L x W x H): 880 x 810 x 1470

- Weight: 460 kg
- Power supply: 400 V 3-phase 50 Hz

Catalogue: 4162

Bulletin: 4165

## Assembly machines



LUBSS



EO-NIROMONT

### Lubricants for tube forming and fitting assembly

These lubricants are approved for use in fitting installation. Compared to universal oil and grease, these high-performance lubricants achieve dramatic torque reduction and superior assembly tool lifetime.

#### Forming lubricant LUBSS

- For flaring and flanging process
- Avoids cold-welding of forming pins
- Results in smooth sealing surfaces
- For maximum tool lifetime

#### Bite-type lubricant EO-NIROMONT

- Preassembly tool and thread lubrication
- Safe cutting function of Progressive Ring
- Mandatory for manual tube fitting assembly
- Ideal for stainless steel thread connections
- Liquid for application on threads
- Paste for application on VOMO, MOK and MOSI tooling

Catalogue: 4100

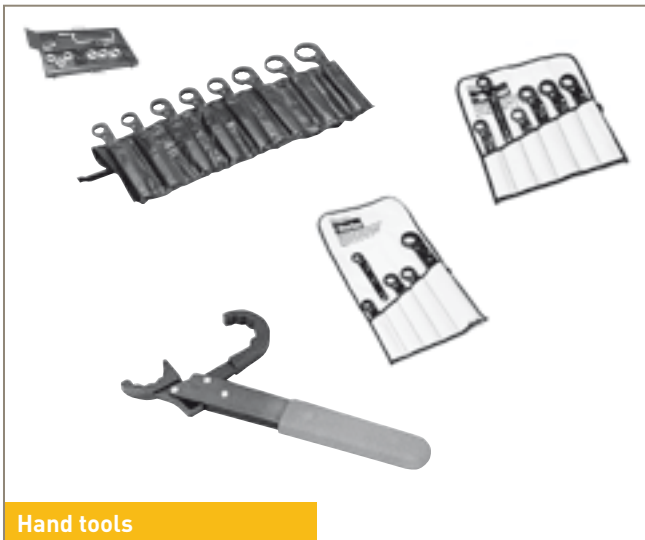

Hand tools

### Hand tools for workshop installation

These workshop tools are ideal for repair work and on-site installation. They are available in standard kits for tube fitting installation.

Bending toolbox  
● Hand bending tool

WZK1  
BV6/18

Cutting and bending toolbox  
● Tube saw square  
● Hacksaw  
● Deburring tools  
● Hand bending tool

WZK2  
AV6/42  
BV6/18

Par-Lok Wrench  
● Snap-action ratchet wrench  
● Inch and metric hex sizes  
● Metric kit (10 wrenches) 10 - 22 mm  
● Inch kit (11 wrenches) 3/8 - 1"  
● O-Lok kit (6 wrenches)  
● Triple-Lok / Ferulok kit (5 wrenches)

Catalogue: 4100

### Assembly machines



#### Tube bending and cutting tools

The manual EO tube cutting and bending tools are ideal for repair work and on-site installation. They are designed for practical clamping in standard vice.

Tube saw square AV6/42

- Tube-OD: 6 - 42 mm

Combined tube bending and cutting tool BAV6/12

- Tube-OD: 6 - 12 mm

In-Ex deburring tool 226

- Tube-OD: 6 - 38 mm

Tube bending tool BV6/18

- Tube-OD: 6 - 18 mm

Tube bending tool BV20/25

- Tube-OD: 20 - 25 mm

Catalogue: 4100



#### Machine renting and leasing programme

Both, purchasing and leasing is possible depending on machine type and volume of business. For limited projects, assembly equipment can be provided on a rental basis.

Special "Demo"-equipment is available for sales presentations and fairs.

Ideal for project work and on-site installation.

Machine Leasing ("hire purchase")

- Alternative to purchase
- No down payment
- Machine is payed off in 24 monthly payments
- New machine, property is passed from Parker to customer

Machine Renting ("hire")

- Ideal for project work
- Machine is rented and returned after project
- Monthly payment for use
- Used machine, property is at Parker

Catalogue: 4100



### Assembly machines



#### Technical support for Parker machines

TFDE machine service procedures ensure that reliable machine function and fitting performance is achieved when using genuine Parker assembly equipment.

All machines come with detailed operating manuals. Parker distributors and sales representatives are trained to give advice on operation and applications. Experienced application engineers at TFDE are available when it comes to special application of TFDE assembly equipment.

In case of machine malfunction, spare machines can be provided on short notice so that production can continue. In the meantime, damaged machinery is checked and repaired at the TFDE machine repair facility. Well trained and experienced engineers take personal care that the machines return properly repaired and tested.

TFDE also offers a machine maintenance and calibration service. Standard spare parts like oil filters can be ordered.

### Assembly machines



#### Mobile bending machine MB 642

The mobile bending machine MB 642 is a compact working centre for hydraulic tubes from 6-42 mm. The basic machine includes a press bender and can be equipped with many additional functions like 37° flaring unit, preassembling metal cutting saw, tube deburring and tooling storage.

The mobile bending machine MB 642 is ideal for workshop use and on-site installation.

Specifications of standard MB 642 machine

- Press bending: Tube-OD up to 42 x 6 mm
- Dimensions (L x W x H): 850 x 500 x 1000 mm
- Weight: 85 kg (standard machine)
- Power supply: 400 Volt - 50 Hz - 3 Ph.

Other MB models and various accessories available.



#### Compact mandrel bending machine DB 642K

The compact mandrel bending machine DB 642K is a robust and practical working centre for tubes from 6-42 mm. The basic machine includes a mandrel bending unit and can be equipped with many additional functions like 37° flaring unit, preassembling metal cutting saw and tube deburring.

The compact mandrel bending machine DB 642K is ideal for universal workshop use.

Specifications of standard DB 642K machine

- Mandrel bending: Tube-OD up to 42 x 6 mm
- Process control: manual
- Dimensions (L x W x H): 4350 x 900 x 1500 mm
- Weight: 1100 kg
- Power supply: 400 Volt - 50 Hz - 3 Ph.

Other K-models for tube OD up to 101mm and various accessories are available

## Assembly machines



DB 650ST

### Stationary mandrel bending machine DB 650ST

Stationary mandrel benders like the model DB 650ST are equipped with a PLC control for easy setup and high repeatability. ST models can also be upgraded with motoric drives for length and rotation to get an automatic bending cycle similar to a CNC machine.

Stationary mandrel benders are ideal for small batches and start-up of serial production.

Specifications of standard DB 650ST machine

- Mandrel bending: Tubes up to 50 mm
- Process control: PLC
- Dimensions (L x W x H): 6000 x 1400 x 1300 mm
- Weight: 2500 kg
- Power supply: 400 Volt - 50 Hz - 3 Ph.

Other ST-models for tube OD up to 90 mm and various accessories are available



DB 642 CNC

### CNC mandrel bender DB 642-CNC

CNC machines are the professional solution for high quality tube bending for small and big tubes starting from 4 mm up to 273 mm tube diameter. Together with bending software "COLLI" the first tube will fit with high precision and repeatability. The machines can also be equipped with boosting and free forming devices and also as right/ left bender for complex geometries.

CNC mandrel benders are ideal for efficient production of small to large batches and even for flexible single piece production.

Specifications of standard DB 642-CNC machine

- Mandrel bending: Tube OD up to 42 mm
- Process control: 3-dimensional CNC
- Dimensions (L x W x H): 625 x 1550 x 1400 mm
- Weight: 3000 kg
- Power supply: 400 Volt - 50 Hz - 3 Ph.

Other CNC-models for tube OD up to 273 mm and various accessories are available

### Assembly machines



RE 642 / RE 2060

#### Deburring machine RE 642 and RE 2060

The RE 642 and RE 2060 deburring machines are portable, practical, universal and safe. Efficient milling tools with a long service life allow deburring of saw cuts in two seconds. One tool set fits for the complete tube range.

The RE 642 and RE 2060 deburring machines are ideal for universal workshop use.

Specifications for standard RE 642 machine

- Deburring: Tube-OD 6-42 mm
- Dimensions: 300 x 400 x 250 mm
- Weight: 28 kg
- Power supply: 400 Volt - 50 Cyl. - 3 Ph.

RE 2060 machine is capable for deburring of tube-OD 20-60 mm.

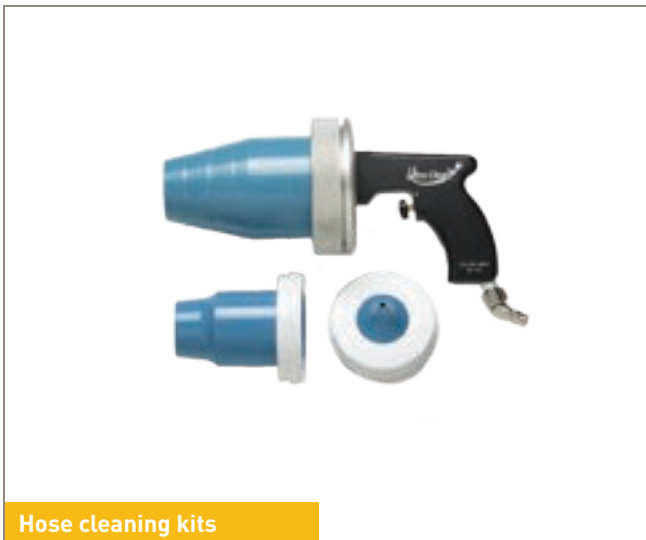

Hose cleaning kits

#### Hose cleaning kits

The TH6-10-HL-9-2 and the TH6-10-EL-7 are used to clean hose assemblies and tubes before installation. Dirt, metal particles and rubber dust are removed by blowing projectiles through the inner diameter.

Both Kits include launcher and nozzles for standard hose sizes in special case. Projectiles and other nozzles available on request.

TH6-10-EL-7 is economic launcher with plastic handle, the robust TH6-10-HL-9-2 is made of aluminium alloy.

Both kits are ideal for universal workshop use.

Specifications

- TH6-10-EL-7: Hose size ¼" - 1 ¼"
- TH6-10-HL-9-2: Hose size ¼" - 2"

Bulletin: 4480-B144



### Assembly machines

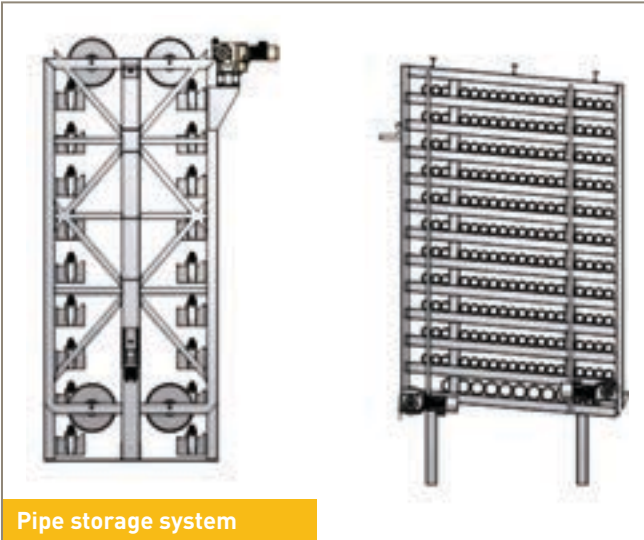

Pipe storage system

#### Pipe storage systems

Special tables are used to separate bundles and allow easy cleaning, inspection, counting or marking of tubes and preparation of manufacturing batches.

Pipe handling and storing systems are essential for managing inventory and minimize commissioning effort.

Special conveyors and buffer tables are used for efficient workflow.

Product range

- Tables for separating tube bundles
- Conveyors and buffer tables for lean workflow
- Paternoster type PN for compact and efficient storing of small to medium tubes
- Automated storage system Type RL for inventory management and commissioning of work orders

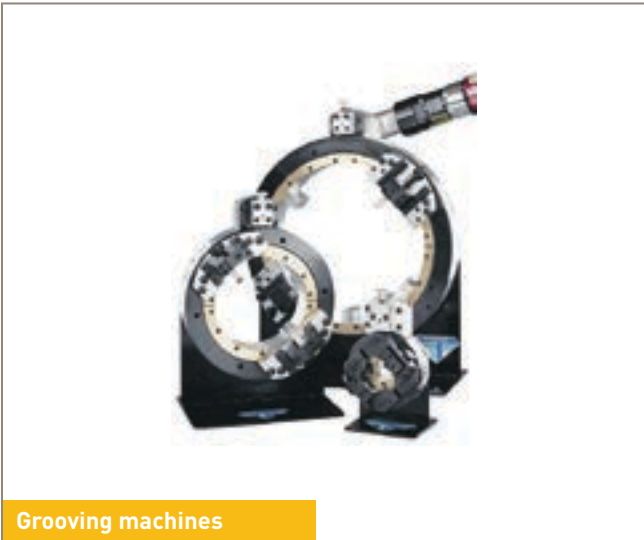

Grooving machines

#### Grooving machines for retaining ring connections

These compact lathes are clamped on OD of tube. Tools are rotating around tube for machining tube end and outer diameter. Special tool bits and spacers are designed according to retaining ring groove specification from Parker.

This portable tool is ideal for workshop use and on-site installation.

Product range

- For tube sizes 1" / 25 mm to 12" / 323.9 mm
- OD groove according Parker specification
- Machining of flat face tube end
- Beveling for welding possible
- Pneumatic or electric motor



ISO 6162-1

F37 seal

on

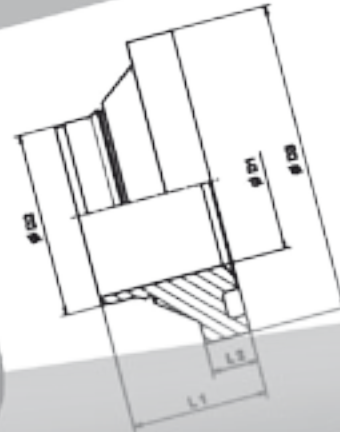

# How to order

## Selecting

1. All flange sizes are clearly listed in the catalogue.

2. Open the catalogue to find the detailed dimensions of your choice.

3. Select the correct order code based on the dimensions of your choice.

| D1   | D2   | D3   | L1   | L2   | Weight (Steel) kg/1 piece | F37 seal Order code | O-Ring Order code | Insert incl. F37 seal + O-Ring Order code |
|------|------|------|------|------|---------------------------|---------------------|-------------------|---|
| 25.0 | 32.8 | 45.0 | 22.0 | 7.0  | 0.11                      | F37S16X             | OR34X1.0X         | IN16-38X2.5TFVCF                          |
| 25.0 | 31.8 | 45.0 | 22.0 | 7.0  | 0.10                      | F37S16X             | OR34X1.0X         | IN16-38X3.0TFVCF                          |
| 25.0 | 29.8 | 45.0 | 22.0 | 7.0  | 0.10                      | F37S16X             | OR30X1.0X         | IN16-38X4.0TFVCF                          |
| 25.0 | 27.8 | 45.0 | 21.0 | 7.0  | 0.09                      | F37S16X             | OR28X1.0X         | IN16-38X5.0TFVCF                          |
| 29.5 | 31.8 | 50.0 | 22.0 | 7.5  | 0.10                      | F37S20X             | OR34X1.0X         | IN16-38X6.0TFVCF                          |
| 27.0 | 29.8 | 50.0 | 22.0 | 7.5  | 0.11                      | F37S20X             | OR30X1.0X         |   |
| 25.5 | 27.8 | 50.0 | 21.0 | 7.0  | 0.10                      | F37S20X             | OR28X1.0X         |   |
| 31.5 | 35.8 | 50.0 | 22.0 | 7.5  | 0.11                      | F37S20X             | OR34X1.0X         |   |
| 31.5 | 33.8 | 50.0 | 22.0 | 7.5  | 0.10                      | F37S20X             | OR30X1.0X         |   |
| 29.5 | 31.8 | 50.0 | 22.0 | 7.5  | 0.10                      | F37S24X             | OR34X1.0X         |   |
| 27.0 | 29.8 | 50.0 | 21.0 | 7.5  | 0.19                      | F37S24X             | OR30X1.0X         |   |
| 25.5 | 27.8 | 50.0 | 22.0 | 7.5  | 0.19                      | F37S24X             | OR28X1.0X         |   |
| 31.5 | 35.8 | 50.0 | 22.0 | 7.5  | 0.20                      | F37S24X             | OR34X1.0X         |   |
| 31.5 | 33.8 | 50.0 | 22.0 | 7.5  | 0.20                      | F37S24X             | OR30X1.0X         |   |
| 33.5 | 35.8 | 60.0 | 25.5 | 10.0 | 0.19                      | F37S32X             | OR44.17X1.78X     | IN32-60X5.0TFVCF                          |
| 31.5 | 33.8 | 60.0 | 25.0 | 10.0 | 0.19                      | F37S32X             | OR41X1.78X        | IN32-60X6.0TFVCF                          |
| 43.8 | 43.8 | 60.0 | 25.5 | 10.0 | 0.22                      | F37S32X             | OR53.7X1.78X      | IN40-60X3.0TFVCF                          |
| 36.0 | 39.8 | 60.0 | 25.5 | 10.0 | 0.24                      | F37S32X             | OR50.52X1.78X     | IN40-60X5.0TFVCF                          |
| 35.0 | 37.8 | 60.0 | 27.0 | 10.0 | 0.27                      | F37S32X             | OR47.37X1.78X     | IN40-60X6.0TFVCF                          |
| 41.5 | 43.8 | 70.0 | 24.0 | 10.0 | 0.27                      | F37S32X             | OR53.7X1.78X      | IN40-60X7.0TFVCF                          |
| 37.5 | 39.8 | 70.0 | 26.5 | 10.0 | 0.24                      | F37S40X             | OR50.52X1.78X     | IN40-73X3.0TFVCF                          |
| 37.8 | 37.8 | 70.0 | 27.0 | 10.0 | 0.24                      | F37S40X             | OR47.37X1.78X     | IN40-73X5.0TFVCF                          |
| 35.0 | 33.8 | 70.0 | 26.5 | 10.0 | 0.23                      | F37S40X             | OR63.22X1.78X     | IN40-75X5.0TFVCF                          |
| 35.0 | 33.8 | 70.0 | 26.5 | 10.0 | 3.50                      | F37S40X             | OR63.22X1.78X     | IN40-75X5.0TFVCF                          |



## Ordering information/Nomenclature

## Parflange® F37 Code Key

Flare Flange Example:

|              |           |                |            |           |
|--------------|-----------|----------------|------------|-----------|
| <b>F37-3</b> | <b>20</b> | <b>-42X3.0</b> | <b>TFV</b> | <b>CF</b> |
|--------------|-----------|----------------|------------|-----------|

| Part code | Flange Type | Flange code | Footprint                   |
|-----------|-------------|-------------|-----------------------------|
| F37       |             | 1           | ISO 6162-1 SAE 1000         |
| F37       |             | 3           | ISO 6162-1 SAE 3000         |
| F37       |             | 6           | ISO 6162-2 SAE 6000         |
| F37       |             | 4           | ISO 6164                    |
| R         |             | 1           | ISO 6162-1 SAE 1000         |
| R         |             | 3           | ISO 6162-1 SAE 3000         |
| R         |             | 6           | ISO 6162-2 SAE 6000         |
| R         |             | 4           | ISO 6164 4 Bolt Flange      |
| R         |             | 8           | *Code 6164 8-12 Bolt Flange |

| Size Code |           |           |           |           |           |           |           |           |           |           |            |            |
|-----------|-----------|-----------|-----------|-----------|-----------|-----------|-----------|-----------|-----------|-----------|------------|------------|
| <b>8</b>  | <b>12</b> | <b>16</b> | <b>20</b> | <b>24</b> | <b>32</b> | <b>40</b> | <b>48</b> | <b>64</b> | <b>80</b> | <b>96</b> | <b>128</b> | <b>160</b> |
| 1/2"      | 3/4"      | 1"        | 1 1/4"    | 1 1/2"    | 2"        | 2 1/2"    | 3"        | 4"        | 5"        | 6"        | 8"         | 10"        |

| Pipe size and Insert Code                 |
|---|
| 42X3.0 / Pipe O. D. X wall thickness (mm) |

| Flange connection/Sealing system |  |
|----------------------------------|--|
| TFV                              | Tube to port connection, F37 seal version    |
| TFB                              | Tube to port connection, Bonded seal version |
| TT                               | Tube to tube connection                      |
| TF                               | Tube to flange connection, Flat face version |

| Material and coating |  |
|----------------------|--|
| CF                   | Steel, Cr(VI)-free                       |
| CFTZN                | Steel, Hot dip galvanized (only Flanges) |
| SS                   | Stainless Steel                          |

\*Code 6164: Flange range related to ISO 6164 Standard  
Bolts and nuts are not components of the complete Part code

### Combination examples

|   | Complete Part No.   | Component                        | No. | Code             | Material           |
|---|---|----------------------------------|-----|------------------|--------------------|
| Standard combination Steel CF                       | F37-320-42X3.0TFVCF<br>Tube to port (F37 seal) 1 1/4"<br>SAE 3000 Flare Flange                                | Flare Flange                     | 1   | F37-320-CFX      | Steel, Cr(VI)-free |
|   |   | Insert incl. O-Ring and F37 Seal | 1   | IN20-42X3.0TFVCF | Steel, Cr(VI)-free |
|   |   | O-Ring                           | 1   | OR37.82X1.78X    | NBR, 90° shore     |
|   |   | F37 Seal                         | 1   | F37S20X          | PUR                |
| Stainless Steel                                     | F37-620-38X4.0TFVSS<br>Tube to port (F37 seal) 1 1/4"<br>SAE 6000 Flare Flange, 38 mm<br>OD tube Jump size    | Flare Flange                     | 1   | F37-620-SSX      | Stainless Steel    |
|   |   | Insert incl. O-Ring and F37 seal | 1   | IN20-38X4.0TFVSS | Stainless Steel    |
|   |   | O-Ring                           | 1   | OR30X1.0X        | NBR, 90° Shore     |
|   |   | F37 seal                         | 1   | F37S20X          | PUR                |
|   |   | Sleeve                           | 1   | SL20-42-38-SSX   | Stainless steel    |
| Hot. dip galv. Flange and<br>Stainless Steel Insert | F37-620-38X4.0TFVSSTZN<br>Tube to port (F37 seal) 1 1/4"<br>SAE 6000 Flare Flange, 38 mm<br>OD tube Jump size | Flare Flange                     | 1   | F37-620-TZN      | Hot dip galv.      |
|   |   | Insert incl. O-Ring and F37 seal | 1   | IN20-38X4.0TFVSS | Stainless steel    |
|   |   | O-Ring                           | 1   | OR30X1.0X        | NBR, 90° Shore     |
|   |   | F37 seal                         | 1   | F37S20X          | PUR                |
|   |   | Sleeve                           | 1   | SL20-42-38-SSX   | Stainless steel    |





## Parflange® Retaining Ring Code Key

Retaining Ring Examples:

|     |    |    |           |   |
|-----|----|----|-----------|---|
| R-1 | 32 | WA | -60.3X2.9 | S |
|-----|----|----|-----------|---|

| Part code | Flange Type | Flange code | Footprint                   |
|-----------|-------------|-------------|-----------------------------|
| F37       |             | 1           | ISO 6162-1 SAE 1000         |
| F37       |             | 3           | ISO 6162-1 SAE 3000         |
| F37       |             | 6           | ISO 6162-2 SAE 6000         |
| F37       |             | 4           | ISO 6164                    |
| R         |             | 1           | ISO 6162-1 SAE 1000         |
| R         |             | 3           | ISO 6162-1 SAE 3000         |
| R         |             | 6           | ISO 6162-2 SAE 6000         |
| R         |             | 4           | ISO 6164 4 Bolt Flange      |
| R         |             | 8           | *Code 6164 8-12 Bolt Flange |

| Size Code |      |    |        |        |    |        |    |    |    |    |     |     |
|-----------|------|----|--------|--------|----|--------|----|----|----|----|-----|-----|
| 8         | 12   | 16 | 20     | 24     | 32 | 40     | 48 | 64 | 80 | 96 | 128 | 160 |
| 1/2"      | 3/4" | 1" | 1 1/4" | 1 1/2" | 2" | 2 1/2" | 3" | 4" | 5" | 6" | 8"  | 10" |

### Weld adapter

### Pipe size and Insert Code

60.3X2.9/Pipe O. D. X wall thickness (mm)

### Material and coating

S Weld Adapter O-Ring Sealing by SAE 1000 (other footprints bonded seal), Steel  
 FS Weld Adapter Flat, Steel  
 SS Weld Adapter O-Ring sealing, Stainless Steel  
 FSS Weld Adapter Flat, Stainless Steel  
 SSTZN Weld Adapter O-Ring sealing, Stainless Steel and hot dip galv. Flange  
 FSSTZN Weld Adapter Flat, Stainless Steel and hot dip galv. Flange

\*Code 6164: Flange range related to ISO 6164 Standard  
 Bolts and nuts are not components of the complete Part code

### Combination examples

|                                  | Complete Part No.   | Component                        | No. | Code                             | Material                             |
|----------------------------------|---|----------------------------------|-----|----------------------------------|--------------------------------------|
| Standard combination<br>Steel CF | R-132WA-60.3X2.9S<br>SAE 1000 Retaining Ring<br>Weld Adapter                                  | Retaining Ring Flange            | 1   | R-132-CFX                        | Steel, Cr(VI)-free                   |
|                                  |   | Retaining Ring                   |     | R32X                             | Stainless Steel                      |
|                                  |   | Weld Adapter body<br>O-Ring      | 1   | WA132-60.3X2.9S<br>OR56.75X3.53X | Steel, Cr(VI)-free<br>NBR, 90° Shore |
| Stainless Steel                  | R-620WA-38X4.0SS<br>SAE 6000 Retaining Ring<br>Weld Adapter                                   | Retaining Ring Flange            | 1   | R-620-SSX                        | Stainless Steel                      |
|                                  |   | Retaining Ring                   | 1   | R20X                             | Stainless Steel                      |
|                                  |   | Weld Adapter body                | 1   | WA20-38X4.0SSX                   | Stainless Steel                      |
|                                  |   | Bonded seal                      | 1   | BS20SSNX                         | NBR, 90° Shore                       |
| Stainless Steel                  | R-PSC8128-250X25VSS<br>SAE 6000 8" Retaining Ring<br>and Pipe seal carrier, 250 mm<br>OD tube | Retaining Ring Flange            | 1   | R-8128-SSX                       | Stainless Steel                      |
|                                  |   | Retaining Ring                   | 1   | R128X                            | Stainless Steel                      |
|                                  |   | Pipe seal carrier incl. F37 seal | 1   | PSC128-250X25VSSX                | Stainless Steel                      |
|                                  |   | F37 seal                         | 1   | F37128X                          | PUR                                  |



















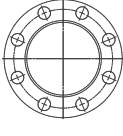

## **SAE 1000 System**

50 – 70 bar

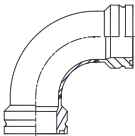
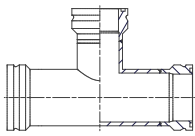
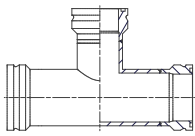
ENGINEERING YOUR SUCCESS.

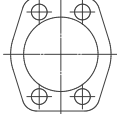
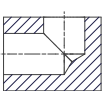
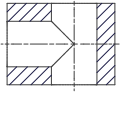
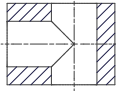
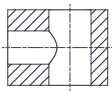
Programme overview SAE 1000/ISO 6162-1 footprint

|                                 |  |  |  |   |  |  |
|---------------------------------|--|--|--|---|--|--|
| Parflange® F37 connection parts | <b>Flanges</b><br><br><b>F37 – p.49</b>   |  |  |   |  |  |
|                                 | <b>Inserts</b><br>  <br><b>TFV – p.51    TF – p.52    TT – p.53</b>   |  |  |   |  |  |
| Retaining ring connection parts | <b>Flanges</b><br>  <br><b>R – p.50    R-Ring – p.54    R – p.50</b>  |  |  |   |  |  |
|                                 | <b>Male / Female</b><br> <br><b>MTF-R – p.55    FTF-R – p.56</b>   |  |  | <b>Weld</b><br> <br><b>WA – p.57    WA-F – p.58</b> |  |  |
|                                 | <b>Tube to Tube</b><br>    <br><b>BF – p.59/60    RF – p.61/62    LF – p.63/64    TF – p.65/66    TF-R – p.65/66</b> |  |  |   |  |  |
|                                 | <b>Blind Flanges</b><br> <br><b>BFV – p.67    CPML – p.68</b>  |  | <b>Blocks see SAE 3000</b><br>   <br><b>LB    LBR    TB    TBR</b> |   |  |  |
| Seals<br>Adapter<br>Bolts       | <b>Bolts and Nuts</b><br><br><b>p.69</b>  |  |  |   |  |  |

**F37 – Flare flange | SAE 1000/ISO 6162-1 footprint**

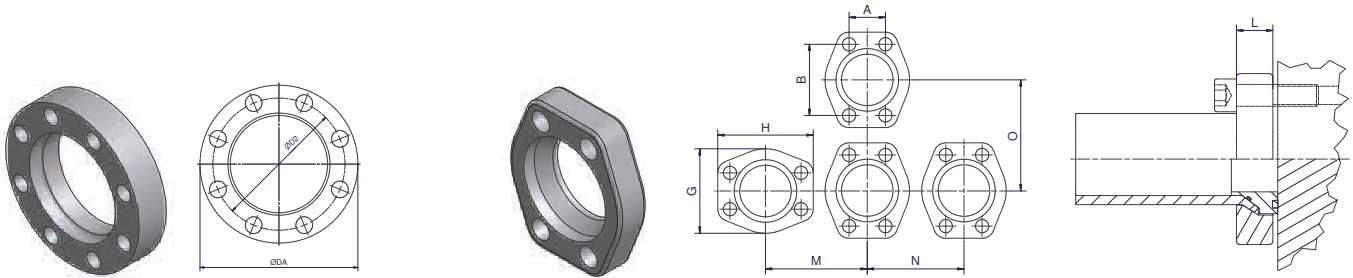

**Parflange F37 flange dimensions**

| Size Inch | Flange Order Code  | A     | B     | G   | H      | M   | N   | O   | L  | Bolts/pc. | Weight (Steel) kg/1 piece | W.P. bar |
|-----------|--------------------|-------|-------|-----|--------|-----|-----|-----|----|-----------|---------------------------|----------|
| 1 1/2     | <b>F37-124-CFX</b> | 35.7  | 69.9  | 83  | 93.75  | 90  | 85  | 96  | 20 | 4         | 0.52                      | 70       |
| 2         | <b>F37-132-CFX</b> | 42.9  | 77.8  | 97  | 101.60 | 102 | 99  | 104 | 25 | 4         | 0.83                      | 70       |
| 2 1/2     | <b>F37-140-CFX</b> | 50.8  | 88.9  | 109 | 114.30 | 114 | 111 | 117 | 30 | 4         | 1.16                      | 70       |
| 3         | <b>F37-148-CFX</b> | 61.9  | 106.4 | 131 | 135.50 | 136 | 133 | 137 | 30 | 4         | 1.57                      | 70       |
| 3 1/2     | <b>F37-156-CFX</b> | 69.9  | 120.7 | 140 | 152.40 | 148 | 142 | 155 | 30 | 4         | 1.99                      | 70       |
| 4         | <b>F37-164-CFX</b> | 77.8  | 130.2 | 152 | 161.95 | 160 | 155 | 164 | 39 | 4         | 2.69                      | 70       |
| 5         | <b>F37-180-CFX</b> | 92.1  | 152.4 | 181 | 184.15 | 186 | 184 | 185 | 39 | 4         | 3.24                      | 70       |
|           |                    | D2    | DA    |     |        |     |     |     |    |           |                           |          |
| 6         | <b>F37-196-CFX</b> | 208.0 | 236.0 |     |        |     |     |     | 39 | 6         | 5.60                      | 50       |

Please change suffixes according to material/surface required

| Order code suffixes             |                             |              |            |
|---------------------------------|-----------------------------|--------------|------------|
| Material                        | Suffix surface and material | Example      | Comments   |
| Steel, zinc plated, Cr(VI)-free | CF                          | F37-320-CFX  |            |
| Stainless steel                 | SS                          | F37-320-SSX  |            |
| Galvanized hot dip zinc         | TZN                         | F37-320-TZNX | on request |

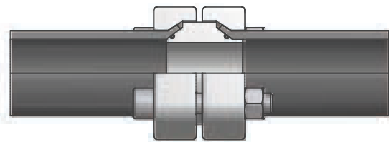

**Part combination flaring SAE 1000**

| Flange Pressure (bar) | Size Inch | Pipe Size | Flange 1000 SAE ISO 6162-1 footprint | Insert*            | O-Ring Insert | Bolts Tube to Port | Bolts Tube to Tube | Nut             |
|-----------------------|-----------|-----------|--------------------------------------|--------------------|---------------|--------------------|--------------------|-----------------|
| <b>70</b>             | 1 1/2     | 50X3.0    | F37-124-CFX                          | IN24-50X3.0T...    | OR47.22X3.53  | 4 x ZYLS12X40      | 4 x ZYLS12X70      | 4 x ISO4032-M12 |
|                       | 2         | 60X3.0    | F37-132-CFX                          | IN32-60X3.0T...    | OR56.75X3.53  | 4 x ZYLS12X45      | 4 x ZYLS12X80      | 4 x ISO4032-M12 |
|                       | 2 1/2     | 75X3.0    | F37-140-CFX                          | IN40-75X3.0T...    | OR69.44X3.53  | 4 x ZYLS12X50      | 4 x ZYLS12X90      | 4 x ISO4032-M12 |
|                       | 3         | 88.9X3.05 | F37-14888.9-CFX                      | IN48-88.9X3.05T... | OR85.32X3.53  | 4 x ZYLS16X60      | 4 x ZYLS16X100     | 4 x ISO4032-M16 |
|                       | 3         | 90X3.5    | F37-148-CFX                          | IN48-90X3.5T...    | OR85.32X3.53  | 4 x ZYLS16X60      | 4 x ZYLS16X100     | 4 x ISO4032-M16 |
|                       | 3 1/2     | 100X4.0   | F37-156-CFX                          | IN56-100X4.0T...   | OR98.02X3.53  | 4 x ZYLS16X55      | 4 x ZYLS16X100     | 4 x ISO4032-M16 |
| <b>50</b>             | 4         | 115X4.0   | F37-164-CFX                          | IN64-115X4.0T...   | OR110.72X3.53 | 4 x ZYLS16X65      | 4 x ZYLS16X120     | 4 x ISO4032-M16 |
|                       | 5         | 140X4.5   | F37-180-CFX                          | IN80-140X4.5T...   | OR136.12X3.53 | 4 x ZYLS16X65      | 4 x ZYLS16X120     | 4 x ISO4032-M16 |
|                       | 6         | 165X5.0   | F37-196-CFX                          | IN96-165X5.0T...   | OR158.34X3.53 | 6 x ZYLS16X65      | 6 x ZYLS16X110     | 6 x ISO4032-M16 |

**Select the complete version:**

- \* ...FVCF Seal version
- ...TCF Tube to Tube version
- ...FCF Flat Face version

Pressure rates related to flanges | Bolt and nuts for flanges see page 67 | Other sizes on request



**R – Retaining ring flange | SAE 1000/ISO 6162-1 footprint**

SAE 1000/ISO 6162-1 footprint

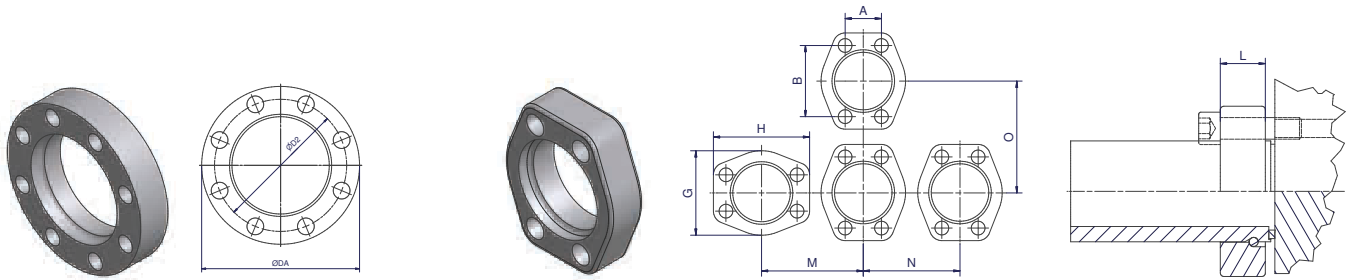

**Retaining Ring Flange dimensions**

| Size Inch | Flange Order code | A    | B     | G   | H      | M   | N   | O   | L  | Bolts/pc. | Weight (Steel) kg/1 piece | W.P. bar |
|-----------|-------------------|------|-------|-----|--------|-----|-----|-----|----|-----------|---------------------------|----------|
| 1 1/2     | <b>R-124-CFX</b>  | 35.7 | 69.9  | 83  | 93.75  | 90  | 85  | 96  | 20 | 4         | 0.46                      | 70       |
| 2         | <b>R-132-CFX</b>  | 42.9 | 77.8  | 97  | 101.60 | 102 | 99  | 104 | 20 | 4         | 0.57                      | 70       |
| 2 1/2     | <b>R-140-CFX</b>  | 50.8 | 88.9  | 109 | 114.30 | 114 | 111 | 117 | 20 | 4         | 0.70                      | 70       |
| 3         | <b>R-148-CFX</b>  | 61.9 | 106.4 | 131 | 135.50 | 136 | 133 | 137 | 25 | 4         | 1.18                      | 70       |
| 3 1/2     | <b>R-156-CFX</b>  | 69.9 | 120.7 | 140 | 152.40 | 148 | 142 | 155 | 29 | 4         | 1.47                      | 70       |
| 4         | <b>R-164-CFX</b>  | 77.8 | 130.2 | 152 | 161.95 | 160 | 155 | 164 | 30 | 4         | 1.74                      | 70       |
| 5         | <b>R-180-CFX</b>  | 92.1 | 152.4 | 181 | 184.15 | 185 | 183 | 186 | 39 | 4         | 2.81                      | 70       |
|           |                   | D2   | DA    |     |        |     |     |     |    |           |                           |          |
| 6         | <b>R-196-CFX</b>  | 208  | 235.5 |     |        |     |     |     | 39 | 6         | 4.96                      | 70       |
| 8         | <b>R-1128-CFX</b> | 275  | 318.0 |     |        |     |     |     | 38 | 8         | 8.95                      | 50       |
| 10        | <b>R-1160-CFX</b> | 345  | 409.6 |     |        |     |     |     | 50 | 8         | 23.29                     | 50       |

Please change suffixes according to material/surface required

| Order code suffixes             |                             |           |
|---------------------------------|-----------------------------|-----------|
| Material                        | Suffix surface and material | Example   |
| Steel, zinc plated, Cr(VI)-free | CF                          | R-124-CFX |
| Stainless steel                 | SS                          | R-124-SSX |
| Galvanized hot dip zinc         | TZN                         | R-124-TZN |

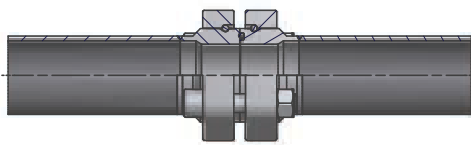

**Part combination retaining ring SAE 1000 (O-Ring) connection**

| Flange pressure (bar) | Size Inch | Flange     | Retaining Ring | O-Ring         | Bolts Tube to Port | Bolts Tube to Tube | Nut             |
|-----------------------|-----------|------------|----------------|----------------|--------------------|--------------------|-----------------|
| 70                    | 1 1/2     | R-124-CFX  | R124X          | OR47.22X3.53X  | 4 x ZYLS12X40      | 4 x ZYLS12X65      | 4 x ISO4032-M12 |
|                       | 2         | R-132-CFX  | R132X          | OR56.75X3.53X  | 4 x ZYLS12X40      | 4 x ZYLS12X65      | 4 x ISO4032-M12 |
|                       | 2 1/2     | R-140-CFX  | R140X          | OR69.44X3.53X  | 4 x ZYLS12X40      | 4 x ZYLS12X65      | 4 x ISO4032-M12 |
|                       | 3         | R-148-CFX  | R148X          | OR85.32x3.53X  | 4 x ZYLS16X50      | 4 x ZYLS16X80      | 4 x ISO4032-M16 |
|                       | 3 1/2     | R-156-CFX  | R156X          | OR98.02X3.53X  | 4 x ZYLS16X55      | 4 x ZYLS16X90      | 4 x ISO4032-M16 |
|                       | 4         | R-164-CFX  | R164X          | OR110.72X3.53X | 4 x ZYLS16X55      | 4 x ZYLS16X90      | 4 x ISO4032-M16 |
|                       | 5         | R-180-CFX  | R180X          | OR136.12X3.53X | 4 x ZYLS16X70      | 4 x ZYLS16X110     | 4 x ISO4032-M16 |
| 50                    | 6         | R-196-CFX  | R196X          | OR158.34X3.53X | 6 x ZYLS16X70      | 6 x ZYLS16X110     | 6 x ISO4032-M16 |
|                       | 8         | R-1128-CFX | R1128X         | OR219.3X5.7X   | 8 x ZYLS20X70      | 8 x ZYLS20X120     | 8 x ISO4032-M20 |
|                       | 10        | R-1160-CFX | R1160X         | OR269.3X5.7X   | 8 x ZYLS20X80      | 8 x ZYLS20X150     | 8 x ISO4032-M20 |

\* Use only for weld adapter and T- and L-adapter flanges | Bolts and nuts are not included in a complete part



## TFV – Flare flange connection

Tube to port connection

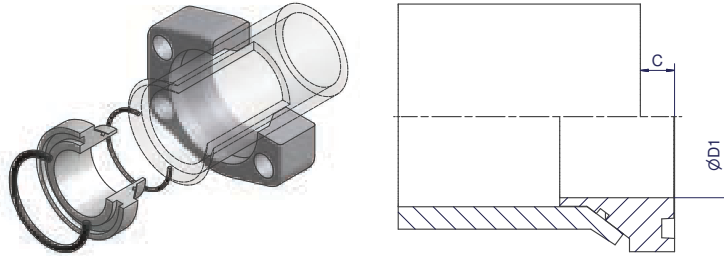

| Size Inch | Tube    | Flange incl. Insert<br>F37 Seal + O-Ring<br>Order code | D1    | C  | Insert<br>incl. 2 x O-Ring Order<br>code | O-Ring<br>Tube Side<br>Order code | O-Ring Seal<br>Port Side<br>Order code | Weight<br>(Steel)<br>kg/1 piece |
|-----------|---------|--|-------|----|--|-----------------------------------|--|---------------------------------|
| 1 1/2     | 50X3.0  | <b>F37-124-50X3.0TFVCF</b>                             | 36.0  | 11 | IN24-50X3.0TFVCF                         | OR44.17X1.78X                     | OR47.22X3.53                           | 0.72                            |
| 2         | 60X3.0  | <b>F37-132-60X3.0TFVCF</b>                             | 46.0  | 12 | IN32-60X3.0TFVCF                         | OR53.7X1.78X                      | OR56.75X3.53                           | 1.10                            |
| 2 1/2     | 75X3.0  | <b>F37-140-75X3.0TFVCF</b>                             | 60.0  | 10 | IN40-75X3.0TFVCF                         | OR69.57X1.78X                     | OR69.44X3.53                           | 1.46                            |
| 3         | 90X3.5  | <b>F37-148-90X3.5TFVCF</b>                             | 72.0  | 15 | IN48-90X3.5TFVCF                         | OR82.27X1.78X                     | OR85.32X3.53                           | 2.17                            |
| 3 1/2     | 100x4.0 | <b>F37-156-100X4.0TFVCF</b>                            | 88.6  | 15 | IN56-100X4.0TFVCF                        | OR98.02X3.53                      | OR98.02X3.53                           | 2.60                            |
| 4         | 115X4.0 | <b>F37-164-115X4.0TFVCF</b>                            | 90.0  | 14 | IN64-115X4.0TFVCF                        | OR110X2X                          | OR110.72X3.53                          | 3.53                            |
| 5         | 140X4.5 | <b>F37-180-140X4.5TFVCF</b>                            | 122.0 | 15 | IN80-140X4.5TFVCF                        | OR129.77X3.53                     | OR136.12X3.53                          | 4.09                            |
| 6         | 165X5.0 | <b>F37-196-165X5.0TFVCF</b>                            | 150.8 | 17 | IN96-165X5.0TFVCF                        | OR158.42X6.26X                    | OR158.34X3.53                          | 6.98                            |

Other sizes on request

Please change suffixes according to material/surface required

| Order code suffixes             |                             |                     |
|---------------------------------|-----------------------------|---------------------|
| Material                        | Suffix surface and material | Example             |
| Steel, zinc plated, Cr(VI)-free | CF                          | F37-124-50X3.0TFVCF |
| Stainless steel                 | SS                          | F37-124-50X3.0TFVSS |

**TF – Flare flange connection**

Tube to port connection, flat face

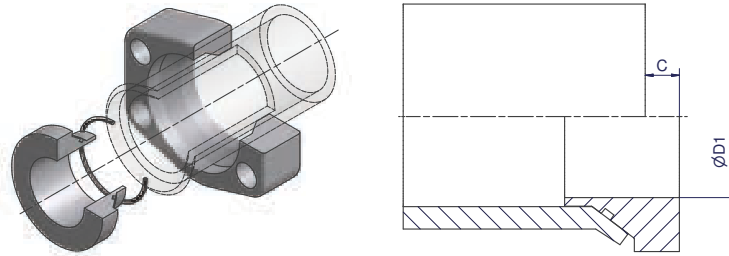

| Size Inch | Tube    | Flange incl. Insert + O-Ring Order code | D1    | C  | Insert incl. O-Ring Order code | O-Ring Tube Side Order code | Weight (Steel) kg/1 piece |
|-----------|---------|---|-------|----|--------------------------------|-----------------------------|---------------------------|
| 1 1/2     | 50X3.0  | <b>F37-124-50X3.0TFCF</b>               | 36.0  | 11 | IN24-50X3.0TFCF                | OR44.17X1.78X               | 0.72                      |
| 2         | 60X3.0  | <b>F37-132-60X3.0TFCF</b>               | 46.0  | 12 | IN32-60X3.0TFCF                | OR53.7X1.78X                | 1.10                      |
| 2 1/2     | 75X3.0  | <b>F37-140-75X3.0TFCF</b>               | 60.0  | 10 | IN40-75X3.0TFCF                | OR69.57X1.78X               | 1.46                      |
| 3         | 90X3.5  | <b>F37-148-90X3.5TFCF</b>               | 72.0  | 15 | IN48-90X3.5TFCF                | OR82.27X1.78X               | 2.17                      |
| 3 1/2     | 100X4.0 | <b>F37-156-100X4.0TFCF</b>              | 88.6  | 15 | IN56-100X4.0TFCF               | OR98.02X3.53X               | 2.60                      |
| 4         | 115X4.0 | <b>F37-164-115X4.0TFCF</b>              | 90.0  | 14 | IN64-115X4.0TFCF               | OR110X2X                    | 3.60                      |
| 5         | 140X4.5 | <b>F37-180-140X4.5TFCF</b>              | 122.0 | 15 | IN80-140X4.5TFCF               | OR129.77X3.53X              | 4.14                      |
| 6         | 165X5.0 | <b>F37-196-165X5.0TFCF</b>              | 150.8 | 17 | IN96-165X5.0TFCF               | OR158.42X6.26X              | 7.03                      |

Other sizes on request

Please change suffixes according to material/surface required

| Order code suffixes             |                             |                 |
|---------------------------------|-----------------------------|-----------------|
| Material                        | Suffix surface and material | Example         |
| Steel, zinc plated, Cr(VI)-free | CF                          | IN24-50X3.0TFCF |
| Stainless steel                 | SS                          | IN24-50X3.0TFSS |



## TT – Flare flange connection

Tube to tube connection

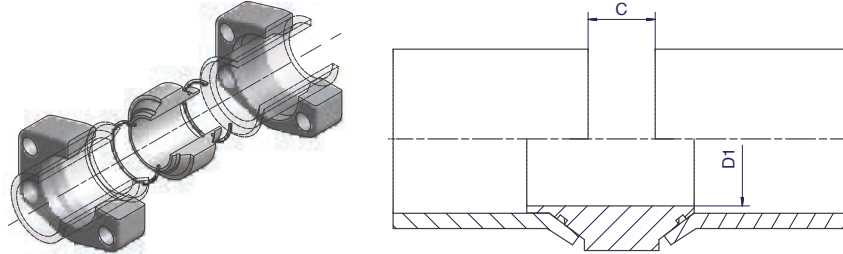

| Size Inch | Tube    | Flange incl.<br>Insert + 2 x O-Ring<br>Order code | D1    | C  | Insert incl.<br>2 x O-Ring<br>Order code | O-Ring<br>Tube Side<br>Order code | Weight<br>(Steel)<br>kg/1 piece |
|-----------|---------|---|-------|----|--|-----------------------------------|---------------------------------|
| 1 1/2     | 50X3.0  | <b>F37-124-50X3.0TTCF</b>                         | 36.0  | 22 | IN24-50X3.0TTCF                          | OR44.17X1.78X                     | 0.94                            |
| 2         | 60X3.0  | <b>F37-132-60X3.0TTCF</b>                         | 46.0  | 24 | IN32-60X3.0TTCF                          | OR53.7X1.78X                      | 1.38                            |
| 2 1/2     | 75X3.0  | <b>F37-140-75X3.0TTCF</b>                         | 60.0  | 20 | IN40-75X3.0TTCF                          | OR69.57X1.78X                     | 1.79                            |
| 3         | 90X3.5  | <b>F37-148-90X3.5TTCF</b>                         | 72.0  | 30 | IN48-90X3.5TTCF                          | OR82.27X1.78X                     | 2.79                            |
| 3 1/2     | 100X4.0 | <b>F37-156-100X4.0TTCF</b>                        | 88.6  | 30 | IN56-100X4.0TTCF                         | OR98.02X3.53X                     | 2.60                            |
| 4         | 115X4.0 | <b>F37-164-115X4.0TTCF</b>                        | 90.0  | 28 | IN64-115X4.0TTCF                         | OR110X2X                          | 4.45                            |
| 5         | 140X4.5 | <b>F37-180-140X4.5TTCF</b>                        | 122.0 | 30 | IN80-140X4.5TTCF                         | OR129.77X3.53X                    | 4.75                            |
| 6         | 165X5.0 | <b>F37-196-165X5.0TTCF</b>                        | 150.8 | 34 | IN96-165X5.0TTCF                         | OR158.42X6.26X                    | 8.36                            |

Other sizes on request

Please change suffixes according to material/surface required

| Order code suffixes             |                             |                    |
|---------------------------------|-----------------------------|--------------------|
| Material                        | Suffix surface and material | Example            |
| Steel, zinc plated, Cr(VI)-free | CF                          | F37-124-50X3.0TTCF |
| Stainless Steel                 | SS                          | F37-124-50X3.0TTSS |

## R – Retaining ring

SAE 1000/ISO 6162-1 footprint

| Size<br>Inch | D     | S   | Order code    |
|--------------|-------|-----|---------------|
| 1 1/2        | 56.0  | 4.0 | <b>R124X</b>  |
| 2            | 66.0  | 4.0 | <b>R132X</b>  |
| 2 1/2        | 77.0  | 4.0 | <b>R140X</b>  |
| 3            | 93.0  | 5.0 | <b>R148X</b>  |
| 3 1/2        | 110.0 | 5.0 | <b>R156X</b>  |
| 4            | 120.0 | 5.0 | <b>R164X</b>  |
| 5            | 144.0 | 6.0 | <b>R180X</b>  |
| 6            | 174.0 | 6.0 | <b>R196X</b>  |
| 8            | 232.0 | 8.0 | <b>R1128X</b> |
| 10           | 286.0 | 8.0 | <b>R1160X</b> |

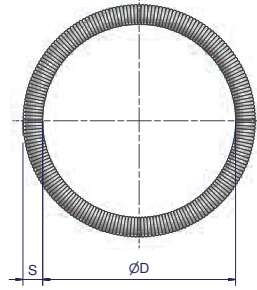



**MTF-R – Male thread adapter, BSPP**

SAE 1000/ISO 6162-1 footprint

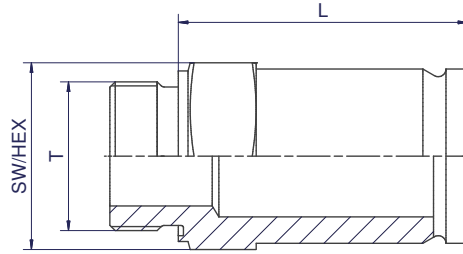
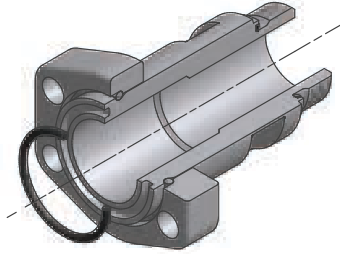

| Size<br>Inch | Complete part<br>Order code | Body incl.<br>ED/Seal<br>Order code | Weight body<br>(Steel)<br>kg/1 piece | L   | T         | SW/<br>HEX |
|--------------|-----------------------------|-------------------------------------|--------------------------------------|-----|-----------|------------|
| 1 1/2        | <b>R-124MTFRCF</b>          | MTF124ROMDCF                        | 1.23                                 | 96  | G 1 1/2 A | 50         |
| 1 1/2        | <b>R-124MTFR11/4CF</b>      | MTF124R11/4OMDCF                    | 1.32                                 | 96  | G 1 1/4 A | 50         |
| 2            | <b>R-132MTFR2CF</b>         | MTF132R2OMDCF                       | 1.83                                 | 97  | G 2 A     | 60         |
| 2            | <b>R-132MTFR11/2CF</b>      | MTF132R11/2OMDCF                    | 1.72                                 | 99  | G 1 1/2 A | 60         |
| 2 1/2        | <b>R-140MTFR2CF</b>         | MTF140R2OMDCF                       | 2.31                                 | 97  | G 2 A     | 70         |
| 2 1/2        | <b>R-140MTFRCF</b>          | MTF140ROMDCF                        | 2.31                                 | 95  | G 2 1/2 A | 70         |
| 3            | <b>R-148MTFR21/2CF</b>      | MTF148R21/2OMDCF                    | 3.79                                 | 120 | G 2 1/2 A | 85         |
| 3            | <b>R-148MTFRCF</b>          | MTF148ROMDCF                        | 3.80                                 | 118 | G 3 A     | 85         |

Other sizes on request

Please change suffixes according to material/surface required

| Order code suffixes             |                             |              |
|---------------------------------|-----------------------------|--------------|
| Material                        | Suffix surface and material | Example      |
| Steel, zinc plated, Cr(VI)-free | CF                          | R-120MTFR1CF |
| Stainless steel                 | SS                          | R-120MTFR1SS |

**FTF-R – Female thread adapter, BSPP**

SAE 1000/ISO 6162-1 footprint

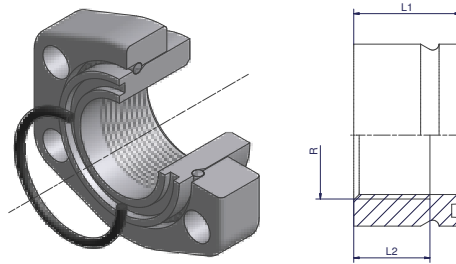

| Size<br>Inch | Complete part<br>Order code | Adapter<br>Order code | Weight<br>(Steel)<br>kg/1 piece | L1 | L2 | R       |
|--------------|-----------------------------|-----------------------|---------------------------------|----|----|---------|
| 1 1/2        | <b>R-124FTFR11/4CF</b>      | FTF124R11/4CFX        | 0.45                            | 45 | 30 | G 1 1/4 |
| 2            | <b>R-132FTFR11/2CF</b>      | FTF132R11/2CFX        | 0.75                            | 55 | 40 | G 1 1/2 |
| 2 1/2        | <b>R-140FTFR2CF</b>         | FTF140R2CFX           | 1.52                            | 80 | 40 | G 2     |
| 3            | <b>R-148FTFR21/2CF</b>      | FTF148R21/2CFX        | 2.11                            | 85 | 50 | G 2 1/2 |

Other sizes on request

Please change suffixes according to material/surface required

| Order code suffixes             |                             |              |
|---------------------------------|-----------------------------|--------------|
| Material                        | Suffix surface and material | Example      |
| Steel, zinc plated, Cr(VI)-free | CF                          | R-120FTFR1CF |
| Stainless steel                 | SS                          | R-120FTFR1SS |



**WA – Weld adapter connection**

SAE 1000/ISO 6162-1 footprint

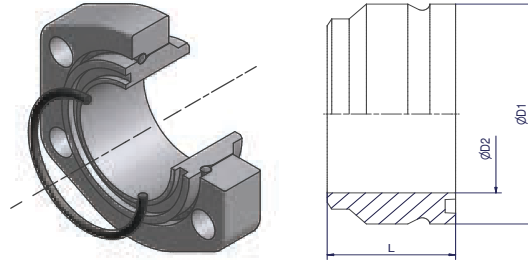

| Size Inch | Tube       | Complete Part Order code    | Weld Adapter Body Order code | Flange Order code | Retaining Ring | O-Ring         | Weight (Steel) kg/1 piece | D1    | D2    | L    |
|-----------|------------|-----------------------------|------------------------------|-------------------|----------------|----------------|---------------------------|-------|-------|------|
| 1 1/2     | 50.0x3.0   | <b>R-124WA-50x3.0S</b>      | WA124-50x3.0SX               | R-124-CFX         | R124X          | OR47.22X3.53X  | 0.80                      | 59.7  | 39.8  | 35.0 |
| 1 1/2     | 48.3X2.6   | <b>R-124WA-48.3X2.6S</b>    | WA124-48.3X2.6SX             | R-124-CFX         | R124X          | OR47.22X3.53X  | 0.80                      | 59.7  | 39.8  | 35.0 |
| 2         | 60.0X3.0   | <b>R-132WA-60x3.0S</b>      | WA132-60X3.0SX               | R-132-CFX         | R132X          | OR56.75X3.53X  | 0.99                      | 69.7  | 50.0  | 35.0 |
| 2         | 60.3X2.9   | <b>R-132WA-60.3X2.9S</b>    | WA132-60.3X2.9SX             | R-132-CFX         | R132X          | OR56.75X3.53X  | 0.99                      | 69.7  | 50.0  | 35.0 |
| 2 1/2     | 75.0x3.0   | <b>R-140WA-75x3.0S</b>      | WA140-75x3.0SX               | R-140-CFX         | R140X          | OR69.44X3.53X  | 1.21                      | 80.7  | 62.0  | 35.0 |
| 2 1/2     | 76.1X3.2   | <b>R-140WA-76.1X3.2S</b>    | WA140-76.1X3.2SX             | R-140-CFX         | R140X          | OR69.44X3.53X  | 1.21                      | 80.7  | 62.0  | 35.0 |
| 3         | 88.9X3.05  | <b>R-148WA-88.9X3.05S</b>   | WA148-88.9X3.05SX            | R-148-CFX         | R148X          | OR85.32X3.53X  | 1.92                      | 97.7  | 77.8  | 40.0 |
| 3         | 88.9X3.6   | <b>R-148WA-88.9X3.6S</b>    | WA148-88.9X3.6SX             | R-148-CFX         | R148X          | OR85.32X3.53X  | 1.92                      | 97.7  | 77.8  | 40.0 |
| 3 1/2     | 100X4.0    | <b>R-156WA-100X4.0S</b>     | WA156-100X4.0SX              | R-156-CFX         | R156X          | OR98.02X3.53X  | 2.70                      | 114.7 | 89.8  | 40.0 |
| 4         | 114.3X4.5  | <b>R-164WA-114.3X4.5S</b>   | WA164-114.3X4.5SX            | R-164-CFX         | R164X          | OR110.72X3.53X | 3.11                      | 124.7 | 99.8  | 40.0 |
| 4         | 115X4.0    | <b>R-164WA-115X4.0S</b>     | WA164-115X4.0SX              | R-164-CFX         | R164X          | OR110.72X3.53X | 3.09                      | 124.7 | 99.8  | 40.0 |
| 5         | 139.7X5.6  | <b>R-180WA-139.7X5.6S</b>   | WA180-139.7X5.6SX            | R-180-CFX         | R180X          | OR136.12X3.53X | 4.92                      | 149.7 | 124.8 | 45.0 |
| 5         | 140x4.5    | <b>R-180WA-140x4.5S</b>     | WA180-140x4.5SX              | R-180-CFX         | R180X          | OR136.12X3.53X | 4.87                      | 149.7 | 124.8 | 45.0 |
| 5         | 141.3X3.4  | <b>R-180WA-141.3X3.4S</b>   | WA180-141.3X3.4SX            | R-180-CFX         | R180X          | OR136.12X3.53X | 4.91                      | 149.7 | 124.8 | 45.0 |
| 6         | 165x5.0    | <b>R-196WA-165x5.0S</b>     | WA196-165x5.0SX              | R-196-CFX         | R196X          | OR158.34X3.53X | 8.02                      | 179.7 | 149.8 | 50.0 |
| 6         | 168.3X2.77 | <b>R-196WA-168.3X2.77S</b>  | WA196-168.3X2.77SX           | R-196-CFX         | R196X          | OR158.34X3.53X | 8.06                      | 179.7 | 149.8 | 50.0 |
| 6         | 168.3X3.4  | <b>R-196WA-168.3X3.4S</b>   | WA196-168.3X3.4SX            | R-196-CFX         | R196X          | OR158.34X3.53X | 8.06                      | 179.7 | 149.8 | 50.0 |
| 8         | 219.1X3.76 | <b>R-1128WA-219.1X3.76S</b> | WA1128-219.1X3.76SX          | R-1128-CFX        | R1128X         | OR219.3X5.7X   | 13.55                     | 239.7 | 206.5 | 60.0 |
| 8         | 219.1X8.18 | <b>R-1128WA-219.1X8.18S</b> | WA1128-219.1X8.18SX          | R-1128-CFX        | R1128X         | OR219.3X5.7X   | 13.55                     | 239.7 | 206.5 | 60.0 |
| 8         | 220X6.0    | <b>R-1128WA-220X6.0S</b>    | WA1128-220X6.0SX             | R-1128-CFX        | R1128X         | OR219.3X5.7X   | 13.62                     | 239.7 | 208.0 | 60.0 |
| 10        | 273X6.0    | <b>R-1160WA-273X6S</b>      | WA1160-273X6SX               | R-1160-CFX        | R1160X         | OR269.3X5.7X   | 32.23                     | 295.0 | 255.0 | 70.0 |
| 10        | 274.1X9.27 | <b>R-1160WA-274.1X9.27S</b> | WA1160-274.1X9.27SX          | R-1160-CFX        | R1160X         | OR269.3X5.7X   | 32.39                     | 295.0 | 255.0 | 70.0 |

Other sizes on request

Please change suffixes according to material/surface required

| Order code suffixes |                             |                  |
|---------------------|-----------------------------|------------------|
| Material            | Suffix surface and material | Example          |
| Steel               | S                           | R-124WA-50x3.0S  |
| Stainless steel     | SS                          | R-124WA-50x3.0SS |

**WAF – Weld adapter flat connection**

SAE 1000/ISO 6162-1 footprint

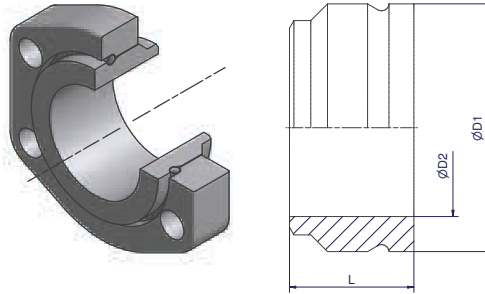

| Size Inch | Tube       | Complete Part Order code     | Weld Adapter Body Order code | Flange Order code | Retaining Ring | Weight (Steel) kg/1 piece | D1    | D2    | L    |
|-----------|------------|------------------------------|------------------------------|-------------------|----------------|---------------------------|-------|-------|------|
| 1 1/2     | 50.0x3.0   | <b>R-124WA-50x3.0FS</b>      | WA124-50x3.0FSX              | R-124-CFX         | R124X          | 0.80                      | 59.7  | 39.8  | 35.0 |
| 1 1/2     | 48.3X2.6   | <b>R-124WA-48.3X2.6FS</b>    | WA124-48.3X2.6FSX            | R-124-CFX         | R124X          | 0.80                      | 59.7  | 39.8  | 35.0 |
| 2         | 60.0X3.0   | <b>R-132WA-60x3.0FS</b>      | WA132-60X3.0FSX              | R-132-CFX         | R132X          | 0.99                      | 69.7  | 50.0  | 35.0 |
| 2         | 60.3X2.9   | <b>R-132WA-60.3X2.9FS</b>    | WA132-60.3X2.9FSX            | R-132-CFX         | R132X          | 1.01                      | 69.7  | 50.0  | 35.0 |
| 2 1/2     | 75.0x3.0   | <b>R-140WA-75x3.0FS</b>      | WA140-75.0x3.0FSX            | R-140-CFX         | R140X          | 1.21                      | 80.7  | 62.0  | 35.0 |
| 2 1/2     | 76.1X3.2   | <b>R-140WA-76.1X3.2FS</b>    | WA140-76.1X3.2FSX            | R-140-CFX         | R140X          | 1.21                      | 80.7  | 62.0  | 35.0 |
| 3         | 88.9X3.05  | <b>R-148WA-88.9X3.05FS</b>   | WA148-88.9X3.05FSX           | R-148-CFX         | R148X          | 1.94                      | 97.7  | 77.8  | 40.0 |
| 3         | 88.9X3.6   | <b>R-148WA-88.9X3.6FS</b>    | WA148-88.9X3.6FSX            | R-148-CFX         | R148X          | 1.94                      | 97.7  | 77.8  | 40.0 |
| 3 1/2     | 100X4.0    | <b>R-156WA-100X4.0FS</b>     | WA156-100X4.0FSX             | R-156-CFX         | R156X          | 2.73                      | 114.7 | 89.8  | 40.0 |
| 4         | 114.3X4.5  | <b>R-164WA-114.3X4.5FS</b>   | WA164-114.3X4.5FSX           | R-164-CFX         | R164X          | 3.15                      | 124.7 | 99.8  | 40.0 |
| 4         | 115X4.0    | <b>R-164WA-115X4.0FS</b>     | WA164-115X4.0FSX             | R-164-CFX         | R164X          | 3.13                      | 124.7 | 99.8  | 40.0 |
| 5         | 139.7X5.6  | <b>R-180WA-139.7X5.6FS</b>   | WA180-139.7X5.6FSX           | R-180-CFX         | R180X          | 4.96                      | 149.7 | 124.8 | 45.0 |
| 5         | 140x4.5    | <b>R-180WA-140x4.5FS</b>     | WA180-140x4.5FSX             | R-180-CFX         | R180X          | 4.92                      | 149.7 | 124.8 | 45.0 |
| 5         | 141.3X3.4  | <b>R-180WA-141.3X3.4FS</b>   | WA180-141.3X3.4FSX           | R-180-CFX         | R180X          | 4.93                      | 149.7 | 124.8 | 45.0 |
| 6         | 165x5.0    | <b>R-196WA-165x5.0FS</b>     | WA196-165x5.0FSX             | R-196-CFX         | R196X          | 8.08                      | 179.7 | 149.8 | 50.0 |
| 6         | 168.3X2.77 | <b>R-196WA-168.3X2.77FS</b>  | WA196-168.3X2.77FSX          | R-196-CFX         | R196X          | 8.16                      | 179.7 | 149.8 | 50.0 |
| 6         | 168.3X3.4  | <b>R-196WA-168.3X3.4FS</b>   | WA196-168.3X3.4FSX           | R-196-CFX         | R196X          | 8.16                      | 179.7 | 149.8 | 50.0 |
| 8         | 219.1X3.76 | <b>R-1128WA-219.1X3.76FS</b> | WA1128-219.1X3.76FSX         | R-1128-CFX        | R1128X         | 13.75                     | 239.7 | 206.5 | 60.0 |
| 8         | 219.1X8.18 | <b>R-1128WA-219.1X8.18FS</b> | WA1128-219.1X8.18FSX         | R-1128-CFX        | R1128X         | 13.75                     | 239.7 | 206.5 | 60.0 |
| 8         | 220X6.0    | <b>R-1128WA-220X6.0FS</b>    | WA1128-220X6.0FSX            | R-1128-CFX        | R1128X         | 13.81                     | 239.7 | 208.0 | 60.0 |
| 10        | 273X6.0    | <b>R-1160WA-273X6FS</b>      | WA1160-273X6FSX              | R-1160-CFX        | R1160X         | 32.47                     | 295.0 | 255.0 | 70.0 |
| 10        | 274.1X9.27 | <b>R-1160WA-274.1X9.27FS</b> | WA1160-274.1X9.27FSX         | R-1160-CFX        | R1160X         | 32.49                     | 295.0 | 255.0 | 70.0 |

Other sizes on request

Please change suffixes according to material/surface required

| Order code suffixes |                             |                   |
|---------------------|-----------------------------|-------------------|
| Material            | Suffix surface and material | Example           |
| Steel               | S                           | R-124WA-50x3.0FS  |
| Stainless steel     | SS                          | R-124WA-50x3.0FSS |



**BF – Bulkhead flange**

SAE 1000/ISO 6162-1 footprint

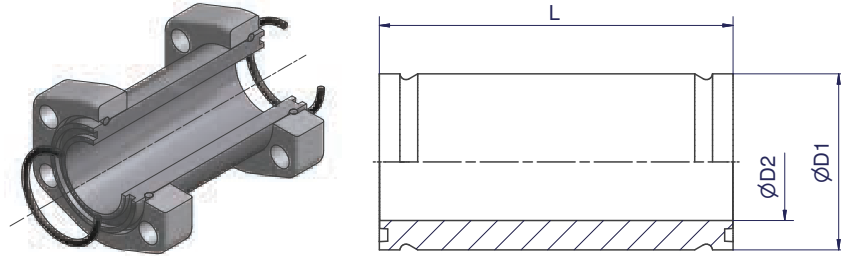

| Size Inch | Complete Part Order code | Bulkhead Body Order code | O-Ring         | Weight body kg/1 piece | D1    | D2    | L   |
|-----------|--------------------------|--------------------------|----------------|------------------------|-------|-------|-----|
| 2         | <b>R-132LBFS</b>         | BF132SX                  | OR56.75X3.53X  | 2.34                   | 69.7  | 50.0  | 165 |
| 2 1/2     | <b>R-140LBFS</b>         | BF140SX                  | OR69.44X3.53X  | 2.81                   | 80.7  | 62.0  | 175 |
| 3         | <b>R-148LBFS</b>         | BF148SX                  | OR85.32X3.53X  | 4.20                   | 97.7  | 77.8  | 200 |
| 3 1/2     | <b>R-156LBFS</b>         | BF156SX                  | OR98.02X3.53X  | 6.15                   | 114.7 | 89.8  | 200 |
| 4         | <b>R-164LBFS</b>         | BF164SX                  | OR110.72X3.53X | 6.75                   | 124.7 | 99.8  | 200 |
| 5         | <b>R-180LBFS</b>         | BF180SX                  | OR136.12X3.53X | 8.22                   | 149.7 | 124.8 | 200 |
| 6         | <b>R-196LBFS</b>         | BF196SX                  | OR158.34X3.53X | 12.81                  | 179.7 | 149.8 | 215 |
| 8         | <b>R-1128LBFS</b>        | BF1128SX                 | OR219.3X5.7X   | 21.18                  | 239.7 | 206.5 | 240 |

Other sizes on request

Please change suffixes according to material/surface required

| Order code suffixes |                             |           |
|---------------------|-----------------------------|-----------|
| Material            | Suffix surface and material | Example   |
| Steel               | S                           | R-132BFS  |
| Stainless steel     | SS                          | R-132BFSS |



## Parflange® F37 – SAE 1000/ISO 6162-1 footprint

### BF – Bulkhead flange flat face

SAE 1000/ISO 6162-1 footprint

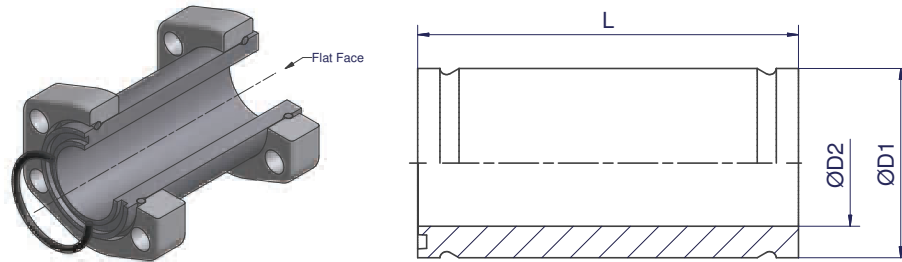

| Size<br>Inch | Complete Part<br>Order code | Bulkhead Body<br>Order code | O-Ring         | Weight<br>body<br>kg/1 piece | D1    | D2    | L   |
|--------------|-----------------------------|-----------------------------|----------------|------------------------------|-------|-------|-----|
| 2            | <b>R-132FBFS</b>            | BF132FSX                    | OR56.75X3.53X  | 2.34                         | 69.7  | 50.0  | 165 |
| 2 1/2        | <b>R-140FBFS</b>            | BF140FSX                    | OR69.44X3.53X  | 2.81                         | 80.7  | 62.0  | 175 |
| 3            | <b>R-148FBFS</b>            | BF148FSX                    | OR85.32X3.53X  | 4.20                         | 97.7  | 77.8  | 200 |
| 3 1/2        | <b>R-156FBFS</b>            | BF156FSX                    | OR98.02X3.53X  | 6.15                         | 114.7 | 89.8  | 200 |
| 4            | <b>R-164FBFS</b>            | BF164FSX                    | OR110.72X3.53X | 6.75                         | 124.7 | 99.8  | 200 |
| 5            | <b>R-180FBFS</b>            | BF180FSX                    | OR136.12X3.53X | 8.22                         | 149.7 | 124.8 | 200 |
| 6            | <b>R-196FBFS</b>            | BF196FSX                    | OR158.34X3.53X | 12.81                        | 179.7 | 149.8 | 215 |
| 8            | <b>R-1128FBFS</b>           | BF1128FSX                   | OR219.3X5.7X   | 21.18                        | 239.7 | 206.5 | 240 |

Other sizes on request

Please change suffixes according to material/surface required

| Order code suffixes |                                |           |
|---------------------|--------------------------------|-----------|
| Material            | Suffix surface<br>and material | Example   |
| Steel               | S                              | R-132BFS  |
| Stainless steel     | SS                             | R-132BFSS |



**RF – Reducer flange**

SAE 1000/ISO 6162-1 footprint

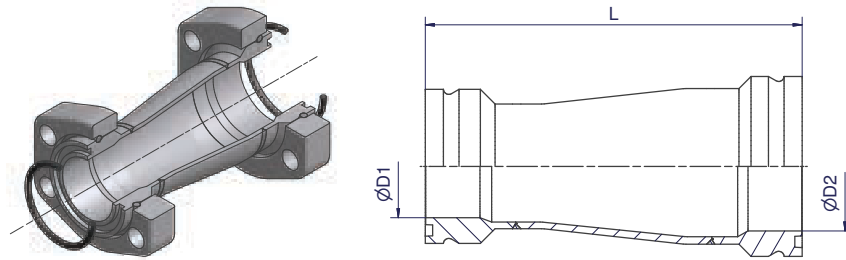

| Size Inch     | Complete Part Order code | Reducer Body Order code | O-Ring D1      | O-Ring D2      | D1    | D2    | L   | Weight (Steel) kg/1 piece | W.P. |
|---------------|--------------------------|-------------------------|----------------|----------------|-------|-------|-----|---------------------------|------|
| 2 - 1 1/2     | <b>R-132-124LRFCF</b>    | RF132-124LOMDCF         | OR56.75X3.53X  | OR47.22X3.53X  | 48.3  | 60.3  | 146 | 0.91                      | 70   |
| 2 1/2 - 1 1/2 | <b>R-140-124LRFCF</b>    | RF140-124LOMDCF         | OR69.44X3.53X  | OR47.22X3.53X  | 48.3  | 76.1  | 160 | 1.04                      | 70   |
| 2 1/2 - 2     | <b>R-140-132LRFCF</b>    | RF140-132LOMDCF         | OR69.44X3.53X  | OR56.75X3.53X  | 60.3  | 76.1  | 160 | 1.25                      | 70   |
| 3 - 1 1/2     | <b>R-148-124LRFCF</b>    | RF148-124LOMDCF         | OR85.32X3.53X  | OR47.22X3.53X  | 48.3  | 88.9  | 165 | 1.34                      | 70   |
| 3 - 2         | <b>R-148-132LRFCF</b>    | RF148-132LOMDCF         | OR85.32X3.53X  | OR56.75X3.53X  | 60.3  | 88.9  | 165 | 1.45                      | 70   |
| 3 - 2 1/2     | <b>R-148-140LRFCF</b>    | RF148-140LOMDCF         | OR85.32X3.53X  | OR69.44X3.53X  | 76.1  | 88.9  | 168 | 1.53                      | 70   |
| 3 1/2 - 2 1/2 | <b>R-156-140LRFCF</b>    | RF156-140LOMDCF         | OR98.02X3.53X  | OR69.44X3.53X  | 79.1  | 108.0 | 177 | 2.00                      | 50   |
| 3 1/2 - 3     | <b>R-156-148LRFCF</b>    | RF156-148LOMDCF         | OR98.02X3.53X  | OR85.32X3.53X  | 88.9  | 108.0 | 182 | 2.32                      | 50   |
| 4 - 3         | <b>R-164-148LRFCF</b>    | RF164-148LOMDCF         | OR110.72X3.53X | OR85.32X3.53X  | 88.9  | 114.3 | 182 | 2.43                      | 50   |
| 5 - 4         | <b>R-180-164LRFCF</b>    | RF180-164LOMDCF         | OR136.12X3.53X | OR110.72X3.53X | 114.3 | 139.7 | 214 | 3.86                      | 50   |

Other sizes on request

Please change suffixes according to material/surface required

| Order code suffixes             |                             |                  |
|---------------------------------|-----------------------------|------------------|
| Material                        | Suffix surface and material | Example          |
| Steel, zinc plated, Cr(VI)-free | CF                          | RF-132-124-LRFCF |
| Stainless steel                 | SS                          | RF-132-124-LRFSS |

## Parflange® F37 – SAE 1000/ISO 6162-1 footprint

### RF – Reducer flange flat face

SAE 1000/ISO 6162-1 footprint

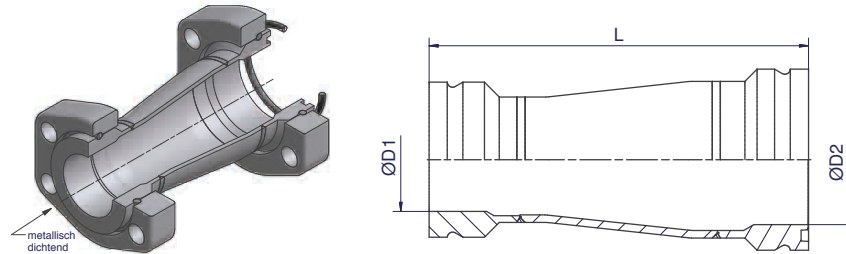

| Size<br>Inch  | Complete Part<br>Order code | Reducer Body<br>Order code | O-Ring         | D1    | D2    | L   | Weight<br>(Steel)<br>kg/1 piece | W.P. |
|---------------|-----------------------------|----------------------------|----------------|-------|-------|-----|---------------------------------|------|
| 2 - 1 1/2     | <b>R-132-124FRFCF</b>       | RF132-124FOMDCF            | OR56.75X3.53X  | 48.3  | 60.3  | 146 | 0.91                            | 70   |
| 2 1/2 - 1 1/2 | <b>R-140-124FRFCF</b>       | RF140-124FOMDCF            | OR69.44X3.53X  | 48.3  | 76.1  | 160 | 1.04                            | 70   |
| 2 1/2 - 2     | <b>R-140-132FRFCF</b>       | RF140-132FOMDCF            | OR69.44X3.53X  | 60.3  | 76.1  | 160 | 1.25                            | 70   |
| 3 - 1 1/2     | <b>R-148-124FRFCF</b>       | RF148-124FOMDCF            | OR85.32X3.53X  | 48.3  | 88.9  | 165 | 1.34                            | 70   |
| 3 - 2         | <b>R-148-132FRFCF</b>       | RF148-132FOMDCF            | OR85.32X3.53X  | 60.3  | 88.9  | 165 | 1.45                            | 70   |
| 3 - 2 1/2     | <b>R-148-140FRFCF</b>       | RF148-140FOMDCF            | OR85.32X3.53X  | 76.1  | 88.9  | 168 | 1.53                            | 70   |
| 3 1/2 - 2 1/2 | <b>R-156-140FRFCF</b>       | RF156-140FOMDCF            | OR98.02X3.53X  | 79.1  | 108.0 | 177 | 2.00                            | 50   |
| 3 1/2 - 3     | <b>R-156-148FRFCF</b>       | RF156-148FOMDCF            | OR98.02X3.53X  | 88.9  | 108.0 | 182 | 2.32                            | 50   |
| 4 - 3         | <b>R-164-148FRFCF</b>       | RF164-148FOMDCF            | OR110.72X3.53X | 88.9  | 114.3 | 182 | 2.43                            | 50   |
| 5 - 4         | <b>R-180-164FRFCF</b>       | RF180-164FOMDCF            | OR136.12X3.53X | 114.3 | 139.7 | 214 | 3.86                            | 50   |

Other sizes on request

Please change suffixes according to material/surface required

| Order code suffixes             |                             |                 |
|---------------------------------|-----------------------------|-----------------|
| Material                        | Suffix surface and material | Example         |
| Steel, zinc plated, Cr(VI)-free | CF                          | RF132-124-FRFCF |
| Stainless steel                 | SS                          | RF132-124-FRFS  |



## LF – Elbow flange

SAE 1000/ISO 6162-1 footprint

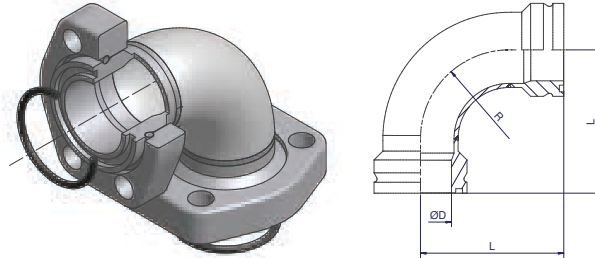

| Size Inch | Elbow Flange Complete Part Order code | Elbow Flange body Order code | O-Ring         | D            | L   | R     | Weight (Steel) kg/1 piece | W.P. |
|-----------|---------------------------------------|------------------------------|----------------|--------------|-----|-------|---------------------------|------|
| 1 1/2     | <b>R-124LLFCF</b>                     | LF124LOMDCF                  | OR47.22X3.53X  | <b>39.8</b>  | 94  | 57.0  | 0.85                      | 70   |
| 2         | <b>R-132LLFCF</b>                     | LF132LOMDCF                  | OR56.75X3.53X  | <b>50.0</b>  | 112 | 76.0  | 1.18                      | 70   |
| 2 1/2     | <b>R-140LLFCF</b>                     | LF140LOMDCF                  | OR69.44X3.53X  | <b>62.0</b>  | 132 | 95.0  | 1.54                      | 70   |
| 3         | <b>R-148LLFCF</b>                     | LF148LOMDCF                  | OR85.32X3.53X  | <b>77.8</b>  | 155 | 114.0 | 2.44                      | 70   |
| 3 1/2     | <b>R-156LLFCF</b>                     | LF156LOMDCF                  | OR98.02X3.53X  | <b>88.9</b>  | 184 | 142.5 | 3.88                      | 50   |
| 4         | <b>R-164LLFCF</b>                     | LF164LOMDCF                  | OR110.72X3.53X | <b>99.8</b>  | 195 | 152.0 | 4.33                      | 50   |
| 5         | <b>R-180LLFCF</b>                     | LF180LOMDCF                  | OR136.12X3.53X | <b>124.8</b> | 235 | 190.0 | 6.81                      | 50   |
| 6         | <b>R-196LLFCF</b>                     | LF196LOMDCF                  | OR158.34X3.53X | <b>149.8</b> | 304 | 229.0 | 11.19                     | 50   |
| 8         | <b>R-1128LLFCF</b>                    | LF1128LOMDCF                 | OR219.3X5.7X   | <b>206.5</b> | 390 | 305.0 | 24.13                     | 50   |
| 10        | <b>R-1160LLFCF</b>                    | LF1160LOMDCF                 | OR269.3X5.7X   | <b>255.0</b> | 471 | 381.0 | 38.39                     | 50   |

Other sizes on request

Please change suffixes according to material/surface required

| Order code suffixes             |                             |            |
|---------------------------------|-----------------------------|------------|
| Material                        | Suffix surface and material | Example    |
| Steel, zinc plated, Cr(VI)-free | CF                          | R-124LLFCF |
| Stainless steel                 | SS                          | R-124LLFSS |

## Parflange® F37 – SAE 1000/ISO 6162-1 footprint

### LF – Elbow flange flat face

SAE 1000/ISO 6162-1 footprint

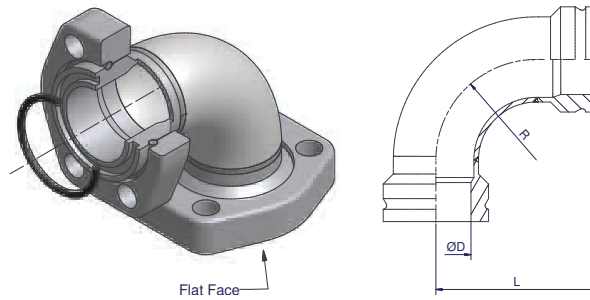

| Size<br>Inch | Elbow Flange<br>Complete Part<br>Order code | Elbow Flange<br>body<br>Order code | O-Ring         | D     | L   | R     | Weight<br>(Steel)<br>kg/1 piece | W.P. |
|--------------|---|------------------------------------|----------------|-------|-----|-------|---------------------------------|------|
| 1 1/2        | <b>R-124FLFCF</b>                           | LF124FOMDCF                        | OR47.22X3.53X  | 39.8  | 94  | 57.0  | 0.85                            | 70   |
| 2            | <b>R-132FLFCF</b>                           | LF132FOMDCF                        | OR56.75X3.53X  | 50.0  | 112 | 76.0  | 1.18                            | 70   |
| 2 1/2        | <b>R-140FLFCF</b>                           | LF140FOMDCF                        | OR69.44X3.53X  | 62.0  | 132 | 95.0  | 1.54                            | 70   |
| 3            | <b>R-148FLFCF</b>                           | LF148FOMDCF                        | OR85.32X3.53X  | 77.8  | 155 | 114.0 | 2.44                            | 70   |
| 3 1/2        | <b>R-156FLFCF</b>                           | LF156FOMDCF                        | OR98.02X3.53X  | 88.9  | 184 | 142.5 | 3.88                            | 50   |
| 4            | <b>R-164FLFCF</b>                           | LF164FOMDCF                        | OR110.72X3.53X | 99.8  | 195 | 152.0 | 4.33                            | 50   |
| 5            | <b>R-180FLFCF</b>                           | LF180FOMDCF                        | OR136.12X3.53X | 124.8 | 235 | 190.0 | 6.81                            | 50   |
| 6            | <b>R-196FLFCF</b>                           | LF196FOMDCF                        | OR158.34X3.53X | 149.8 | 304 | 229.0 | 11.19                           | 50   |
| 8            | <b>R-1128FLFCF</b>                          | LF1128FOMDCF                       | OR219.3X5.7X   | 206.5 | 390 | 305.0 | 24.13                           | 50   |
| 10           | <b>R-1160FLFCF</b>                          | LF1160FOMDCF                       | OR269.3X5.7X   | 255.0 | 471 | 381.0 | 38.39                           | 50   |

Other sizes on request

Please change suffixes according to material/surface required

| Order code suffixes             |                                |            |
|---------------------------------|--------------------------------|------------|
| Material                        | Suffix surface<br>and material | Example    |
| Steel, zinc plated, Cr(VI)-free | CF                             | R-124FLFCF |
| Stainless steel                 | SS                             | R-124FLFSS |





**TF/TF-R – TEE flange**

SAE 1000/ISO 6162-1 footprint

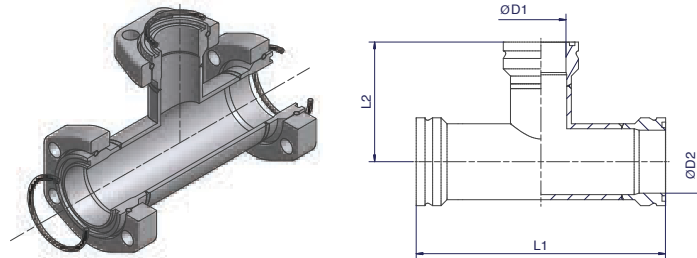

| Size Inch     | Tee Flange Complete Part Order code | Tee Flange body Order code | O-Ring D1      | O-Ring D2      | D1    | D2    | L1  | L2  | Weight (Steel) kg/1 piece | W.P. |
|---------------|-------------------------------------|----------------------------|----------------|----------------|-------|-------|-----|-----|---------------------------|------|
| 1 1/2         | <b>R-124LTFCF</b>                   | TF124LOMDCF                | OR47.22X3.53X  | OR47.22X3.53X  | 39.8  | 39.8  | 184 | 92  | 1.30                      | 70   |
| 2-1 1/2-2     | <b>R-132-124-132LTFCF</b>           | TF132-124-132LOMDCF        | OR47.22X3.53X  | OR56.75X3.53X  | 39.8  | 50.0  | 200 | 97  | 1.58                      | 70   |
| 2             | <b>R-132LTFCF</b>                   | TF132LOMDCF                | OR56.75X3.53X  | OR56.75X3.53X  | 50.0  | 50.0  | 198 | 99  | 1.67                      | 70   |
| 2 1/2-2-2 1/2 | <b>R-140-132-140LTFCF</b>           | TF140-132-140LOMDCF        | OR56.75X3.53X  | OR69.44X3.53X  | 50.0  | 62.0  | 222 | 105 | 2.02                      | 70   |
| 2 1/2         | <b>R-140LTFCF</b>                   | TF140LOMDCF                | OR69.44X3.53X  | OR69.44X3.53X  | 62.0  | 62.0  | 222 | 111 | 2.09                      | 70   |
| 3-2 1/2-3     | <b>R-148-140-148LTFCF</b>           | TF148-140-148LOMDCF        | OR69.44X3.53X  | OR85.32X3.53X  | 62.0  | 77.8  | 252 | 118 | 2.91                      | 70   |
| 3             | <b>R-148LTFCF</b>                   | TF148LOMDCF                | OR85.32X3.53X  | OR85.32X3.53X  | 77.8  | 77.8  | 252 | 126 | 3.22                      | 70   |
| 3 1/2-3-3 1/2 | <b>R-156-148-156LTFCF</b>           | TF156-148-156LOMDCF        | OR85.32X3.53X  | OR98.02X3.53X  | 77.8  | 89.8  | 283 | 137 | 4.47                      | 50   |
| 3 1/2         | <b>R-156LTFCF</b>                   | TF156LOMDCF                | OR98.02X3.53X  | OR98.02X3.53X  | 89.8  | 89.8  | 283 | 140 | 4.86                      | 50   |
| 4-3-4         | <b>R-164-148-164LTFCF</b>           | TF164-148-164LOMDCF        | OR85.32X3.53X  | OR110.72X3.53X | 77.8  | 99.8  | 293 | 138 | 4.84                      | 50   |
| 4             | <b>R-164LTFCF</b>                   | TF164LOMDCF                | OR110.72X3.53X | OR110.72X3.53X | 99.8  | 99.8  | 293 | 145 | 5.37                      | 50   |
| 5-4-5         | <b>R-180-164-180LTFCF</b>           | TF180-164-180LOMDCF        | OR110.72X3.53X | OR136.12X3.53X | 99.8  | 124.8 | 340 | 157 | 7.39                      | 50   |
| 5             | <b>R-180LTFCF</b>                   | TF180LOMDCF                | OR136.12X3.53X | OR136.12X3.53X | 124.8 | 124.8 | 341 | 169 | 8.04                      | 50   |
| 6-5-6         | <b>R-196-180-196LTFCF</b>           | TF196-180-196LOMDCF        | OR136.12X3.53X | OR158.34X3.53X | 124.8 | 149.8 | 426 | 188 | 11.49                     | 50   |
| 6             | <b>R-196LTFCF</b>                   | TF196LOMDCF                | OR158.34X3.53X | OR158.34X3.53X | 149.8 | 149.8 | 439 | 218 | 12.87                     | 50   |
| 8-6-8         | <b>R-1128-196-1128LTFCF</b>         | TF1128-196-1128LOMDCF      | OR158.34X3.53X | OR219.3X5.7X   | 149.8 | 206.5 | 528 | 243 | 22.66                     | 50   |
| 8             | <b>R-1128LTFCF</b>                  | TF1128LOMDCF               | OR219.3X5.7X   | OR219.3X5.7X   | 206.5 | 206.5 | 529 | 263 | 25.58                     | 50   |
| 10            | <b>R-1160LTFCF</b>                  | TF1160LOMDCF               | OR269.3X5.7X   | OR269.3X5.7X   | 255.0 | 255.0 | 612 | 306 | 40.16                     | 50   |

Other sizes on request

Please change suffixes according to material/surface required

| Order code suffixes             |                             |            |
|---------------------------------|-----------------------------|------------|
| Material                        | Suffix surface and material | Example    |
| Steel, zinc plated, Cr(VI)-free | CF                          | R-124LTFCF |
| Stainless steel                 | SS                          | R-124LTSS  |

**TF/TF-R – TEE flange flat**

SAE 1000/ISO 6162-1 footprint

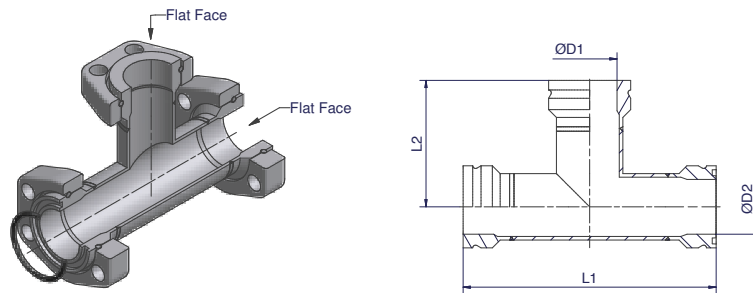

| Size Inch     | Tee Flange Complete Part Order code | Tee Flange Body Order code | O-Ring         | D1    | D2    | L1  | L2  | Weight (Steel) kg/1 piece | W.P. |
|---------------|-------------------------------------|----------------------------|----------------|-------|-------|-----|-----|---------------------------|------|
| 1 1/2         | <b>R-124FTFCF</b>                   | TF124FOMDCF                | OR47.22X3.53X  | 39.8  | 39.8  | 184 | 92  | 1.30                      | 70   |
| 2-1 1/2-2     | <b>R-132-124-132FTFCF</b>           | TF132-124-132FOMDCF        | OR56.75X3.53X  | 39.8  | 50.0  | 200 | 97  | 1.58                      | 70   |
| 2             | <b>R-132FTFCF</b>                   | TF132FOMDCF                | OR56.75X3.53X  | 50.0  | 50.0  | 198 | 99  | 1.67                      | 70   |
| 2 1/2-2-2 1/2 | <b>R-140-132-140FTFCF</b>           | TF140-132-140FOMDCF        | OR69.44X3.53X  | 50.0  | 62.0  | 222 | 105 | 2.02                      | 70   |
| 2 1/2         | <b>R-140FTFCF</b>                   | TF140FOMDCF                | OR69.44X3.53X  | 62.0  | 62.0  | 222 | 111 | 2.09                      | 70   |
| 3-2 1/2-3     | <b>R-148-140-148FTFCF</b>           | TF148-140-148FOMDCF        | OR85.32X3.53X  | 62.0  | 77.8  | 252 | 118 | 2.91                      | 70   |
| 3             | <b>R-148FTFCF</b>                   | TF148FOMDCF                | OR85.32X3.53X  | 77.8  | 77.8  | 252 | 126 | 3.22                      | 70   |
| 3 1/2-3-3 1/2 | <b>R-156-148-156FTFCF</b>           | TF156-148-156FOMDCF        | OR98.02X3.53X  | 77.8  | 89.8  | 283 | 137 | 4.47                      | 50   |
| 3 1/2         | <b>R-156FTFCF</b>                   | TF156FOMDCF                | OR98.02X3.53X  | 89.8  | 89.8  | 283 | 140 | 4.86                      | 50   |
| 4-3-4         | <b>R-164-148-164FTFCF</b>           | TF164-148-164FOMDCF        | OR110.72X3.53X | 77.8  | 99.8  | 293 | 138 | 4.84                      | 50   |
| 4             | <b>R-164FTFCF</b>                   | TF164FOMDCF                | OR110.72X3.53X | 99.8  | 99.8  | 293 | 145 | 5.37                      | 50   |
| 5-4-5         | <b>R-180-164-180FTFCF</b>           | TF180-164-180FOMDCF        | OR136.12X3.53X | 99.8  | 124.8 | 340 | 157 | 7.39                      | 50   |
| 5             | <b>R-180FTFCF</b>                   | TF180FOMDCF                | OR136.12X3.53X | 124.8 | 124.8 | 341 | 169 | 8.04                      | 50   |
| 6-5-6         | <b>R-196-180-196FTFCF</b>           | TF196-180-196FOMDCF        | OR158.34X3.53X | 124.8 | 149.8 | 426 | 188 | 11.49                     | 50   |
| 6             | <b>R-196FTFCF</b>                   | TF196FOMDCF                | OR158.34X3.53X | 149.8 | 149.8 | 439 | 218 | 12.87                     | 50   |
| 8-6-8         | <b>R-1128-196-1128FTFCF</b>         | TF1128-196-1128FOMDCF      | OR219.3X5.7X   | 149.8 | 206.5 | 528 | 243 | 22.66                     | 50   |
| 8             | <b>R-1128FTFCF</b>                  | TF1128FOMDCF               | OR219.3X5.7X   | 206.5 | 206.5 | 529 | 263 | 25.58                     | 50   |
| 10            | <b>R-1160FTFCF</b>                  | TF1160FOMDCF               | OR269.3X5.7X   | 255.0 | 255.0 | 612 | 306 | 40.16                     | 50   |

Other sizes on request

Please change suffixes according to material/surface required

| Order code suffixes             |                             |            |
|---------------------------------|-----------------------------|------------|
| Material                        | Suffix surface and material | Example    |
| Steel, zinc plated, Cr(VI)-free | CF                          | R-124FTFCF |
| Stainless steel                 | SS                          | R-124FTFSS |



**BFV – Blind flange**

SAE 1000/ISO 6162-1

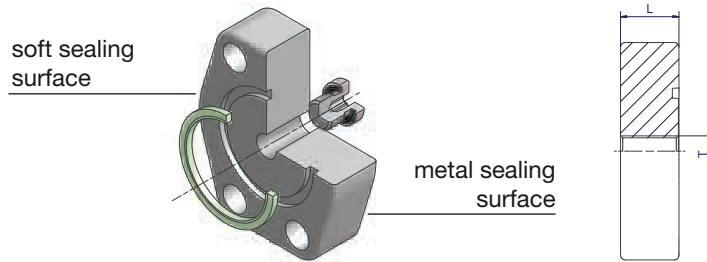

| Size<br>Inch | L  | T     | Flange incl.<br>VSTI-ED and F37 Seal<br>Order code | Weight<br>(Steel)<br>kg/1 piece |
|--------------|----|-------|--|---------------------------------|
| 1 1/2        | 20 | G 1/4 | <b>F37-124BFVCF</b>                                | 0.9                             |
| 2            | 25 | G 1/4 | <b>F37-132BFVCF</b>                                | 1.5                             |
| 2 1/2        | 30 | G 1/4 | <b>F37-140BFVCF</b>                                | 2.3                             |
| 3            | 30 | G 1/4 | <b>F37-148BFVCF</b>                                | 3.2                             |
| 3 1/2        | 30 | G 1/4 | <b>F37-156BFVCF</b>                                | 4.0                             |
| 4            | 39 | G 1/4 | <b>F37-164BFVCF</b>                                | 6.1                             |
| 5            | 39 | G 1/4 | <b>F37-180BFVCF</b>                                | 8.3                             |
| 6            | 39 | G 1/4 | <b>F37-196BFVCF</b>                                | 12.9                            |

Other sizes on request

Please change suffixes according to material/surface required

| Order code suffixes             |                             |              |
|---------------------------------|-----------------------------|--------------|
| Material                        | Suffix surface and material | Example      |
| Steel, zinc plated, Cr(VI)-free | CF                          | F37-120BFVCF |
| Stainless steel                 | SS                          | F37-120BFVSS |

## Parflange® F37 – SAE 1000/ISO 6162-1 footprint

### CPML – F37 inner plate

SAE 1000/ISO 6162-1 footprint

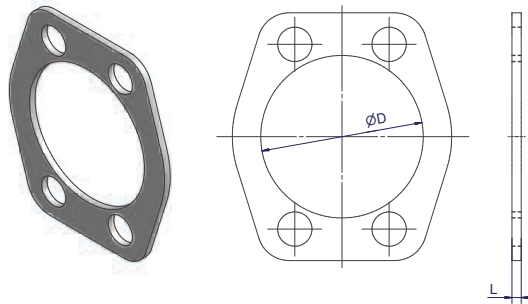

| Size<br>Inch | L   | D    | F37<br>Inner Plate<br>Order code | Weight<br>(Steel)<br>kg/1 piece |
|--------------|-----|------|----------------------------------|---------------------------------|
| 1 1/2        | 3.5 | 39.8 | <b>24CPMLCFX</b>                 | 0.13                            |
| 2            | 3.5 | 50.0 | <b>32CPMLCFX</b>                 | 0.15                            |
| 2 1/2        | 3.5 | 62.0 | <b>40CPMLCFX</b>                 | 0.19                            |
| 3            | 3.5 | 77.8 | <b>48CPMLCFX</b>                 | 0.25                            |

Other sizes on request

Please change suffixes according to material/surface required

| Order code suffixes |                             |           |
|---------------------|-----------------------------|-----------|
| Material            | Suffix surface and material | Example   |
| Steel               | CF                          | 24CPMLCFX |
| Stainless steel     | SS                          | 24CPMLSSX |



## Bolts and nuts for flange

SAE 1000/ISO 6162-1 footprint



### F37 Flare Flange

| Size<br>Inch | Flange       | Soft Seal / Flat Face |                       | Nut             |
|--------------|--------------|-----------------------|-----------------------|-----------------|
|              |              | Bolts<br>Tube to Port | Bolts<br>Tube to Tube |                 |
| 1 1/2        | F37-124-CFX  | 4 x ZYLS12X40         | 4 x ZYLS12X70         | 4 x ISO4032-M12 |
| 2            | F37-132-CFX  | 4 x ZYLS12X45         | 4 x ZYLS12X80         | 4 x ISO4032-M12 |
| 2 1/2        | F37-140-CFX  | 4 x ZYLS12X50         | 4 x ZYLS12X90         | 4 x ISO4032-M12 |
| 3            | F37-148-CFX  | 4 x ZYLS16X60         | 4 x ZYLS16X100        | 4 x ISO4032-M16 |
| 3 1/2        | F37-156-CFX  | 4 x ZYLS16X60         | 4 x ZYLS16X100        | 4 x ISO4032-M16 |
| 4            | F37-164-CFX  | 4 x ZYLS16X65         | 4 x ZYLS16X120        | 4 x ISO4032-M16 |
| 5            | F37-180-CFX  | 4 x ZYLS16X65         | 4 x ZYLS16X120        | 4 x ISO4032-M16 |
| 6            | F37-196-CFX  | 6 x ZYLS16X65         | 6 x ZYLS16X110        | 6 x ISO4032-M16 |
| 8            | F37-1128-CFX | 8 x ZYLS20X80         | 8 x ZYLS20X145        | 8 x ISO4032-M20 |

### Retaining Ring Flange

| Size<br>Inch | Flange     | Soft Seal / Flat Face |                       | Nut             |
|--------------|------------|-----------------------|-----------------------|-----------------|
|              |            | Bolts<br>Tube to Port | Bolts<br>Tube to Tube |                 |
| 1 1/2        | R-124-CFX  | 4 x ZYLS12X40         | 4 x ZYLS12X65         | 4 x ISO4032-M12 |
| 2            | R-132-CFX  | 4 x ZYLS12X40         | 4 x ZYLS12X65         | 4 x ISO4032-M12 |
| 2 1/2        | R-140-CFX  | 4 x ZYLS12X40         | 4 x ZYLS12X65         | 4 x ISO4032-M12 |
| 3            | R-148-CFX  | 4 x ZYLS16X50         | 4 x ZYLS16X80         | 4 x ISO4032-M16 |
| 3 1/2        | R-156-CFX  | 4 x ZYLS16X55         | 4 x ZYLS16X90         | 4 x ISO4032-M16 |
| 4            | R-164-CFX  | 4 x ZYLS16X55         | 4 x ZYLS16X90         | 4 x ISO4032-M16 |
| 5            | R-180-CFX  | 4 x ZYLS16X70         | 4 x ZYLS16X110        | 4 x ISO4032-M16 |
| 6            | R-196-CFX  | 6 x ZYLS16X70         | 6 x ZYLS16X110        | 6 x ISO4032-M16 |
| 8            | R-1128-CFX | 8 x ZYLS20X70         | 8 x ZYLS20X120        | 8 x ISO4032-M20 |
| 10           | R-1160-CFX | 8 x ZYLS20X80         | 8 x ZYLS20X150        | 8 x ISO4032-M20 |

Bolts and nuts must be ordered separately.

Latest information about nuts and bolts see [www.parker.com/tfde/servicemanuals/userguides](http://www.parker.com/tfde/servicemanuals/userguides)

Please add the suffixes according to the bolt quality

| Quality | Steel             |                  | Stainless Steel  |
|---------|-------------------|------------------|------------------|
|         | 8.8               | 10.9             | A4-80X           |
| Bolt    | ZYLS16X60X        | ZYLS16X60109X    | ZYLS16X60A4-80X  |
| Nut     | ISO-4032-M12-8VZX | ISO-4032-M12-10X | ISO-4032-M12-80X |

















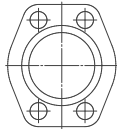
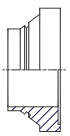
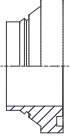
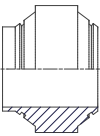

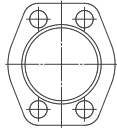

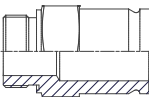
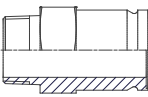

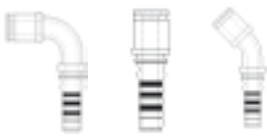
## **SAE 3000 System**

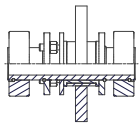
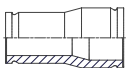
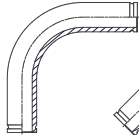
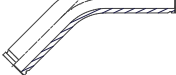
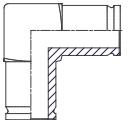
210 – 350 bar

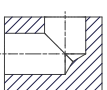
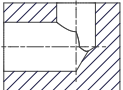
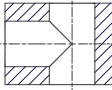
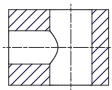
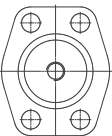
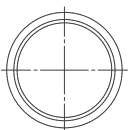
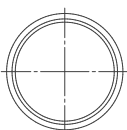
ENGINEERING YOUR SUCCESS.

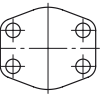

Programme overview SAE 3000/ISO 6162-1 footprint

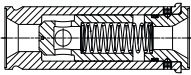
|                                 |  |  |  |  |  |   |
|---------------------------------|--|--|--|--|--|---|
| Parflange® F37 connection parts | <b>Flanges</b><br><br><b>F37</b> – p.74/75  |  |  |  |  |   |
|                                 | <b>Inserts</b><br>   <br><b>TFB</b> – p.78 <b>TFV</b> – p.79 <b>TT</b> – p.80 <b>TF</b> – p.81   |  |  |  | <b>Sleeve</b><br><br><b>SL</b> – p.82 |   |
| Retaining ring connection parts | <b>Flanges</b><br>  <br><b>R</b> – p.76 <b>R-Ring</b> – p.83 <b>PSC</b> – p.77  |  |  |  |  |   |
|                                 | <b>Male / Female</b><br>  <br><b>MTF-R</b> – p.84 <b>MTF-N</b> – p.85 <b>FTF-R</b> – p.86   |  |  | <b>Hose</b><br><br><b>Hose</b> – p.87 |  | <b>Weld</b><br><br><b>WA</b> – p.88/89 |
|                                 | <b>Tube to Tube</b><br>      <br><b>BF</b> – p.90 <b>VB</b> – p.91 <b>RF</b> – p.92 <b>FB90</b> – p.93/95 <b>FB45</b> – p.94/96 <b>LF</b> – p.97 <b>TF</b> – p.98 |  |  |  |  |   |
| SAE connection parts            | <b>Blocks</b><br>    <br><b>LB</b> – p.99 <b>LBR</b> – p.100 <b>TB</b> – p.101 <b>TBR</b> – p.102 <b>BFV</b> – p.103  |  |  |  |  |   |
| Seals<br>Adapter<br>Bolts       | <b>Components</b><br>    <br><b>BS</b> – p.104 <b>F37S</b> – p.104 <b>AO</b> – p.105 <b>TBT</b> – p.106 <b>AP</b> – p.107   |  |  |  |  | <b>Bolts and Nuts</b><br><br>p.108     |
| Ball valves                     |    <br><b>KH</b> – p.109 <b>KH</b> – p.110-112 <b>KH-R</b> – p.113 <b>RHD-R</b> – p.114   |  |  |  |  |   |

**F37 – Flare flange | SAE 3000/ISO 6162-1 footprint**

SAE 3000/ISO 6162-1

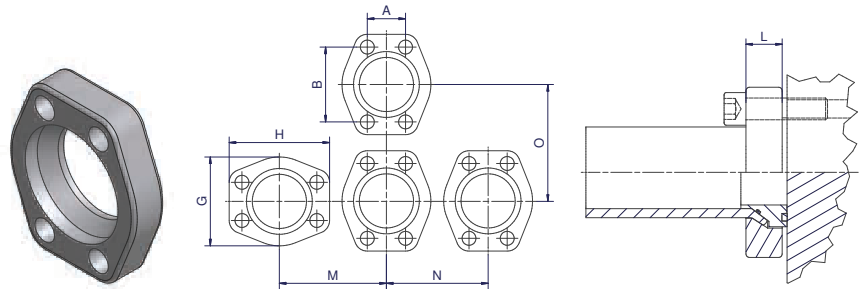

**Parflange F37 flange dimensions**

\*Jump size flanges (no adapter sleeves (SL...) necessary)

| Size<br>Inch | Flange<br>Order code   | A    | B     | G   | H     | M   | N   | O   | L  | Weight<br>(Steel)<br>kg/1 piece | W.P. bar |
|--------------|------------------------|------|-------|-----|-------|-----|-----|-----|----|---------------------------------|----------|
| 1/2          | <b>F37-308-CFX</b>     | 17.5 | 38.1  | 46  | 54.0  | 52  | 49  | 56  | 19 | 0.20                            | 350      |
| 1/2          | <b>F37-308/16-CFX*</b> | 17.5 | 38.1  | 46  | 54.0  | 52  | 49  | 56  | 19 | 0.22                            | 350      |
| 3/4          | <b>F37-312-CFX</b>     | 22.3 | 47.6  | 52  | 65.0  | 61  | 55  | 68  | 20 | 0.25                            | 350      |
| 1            | <b>F37-316-CFX</b>     | 26.2 | 52.4  | 60  | 71.0  | 67  | 61  | 72  | 24 | 0.30                            | 350      |
| 1            | <b>F37-316/25-CFX*</b> | 26.2 | 52.4  | 60  | 71.0  | 67  | 61  | 72  | 24 | 0.45                            | 350      |
| 1            | <b>F37-316/30-CFX*</b> | 26.2 | 52.4  | 60  | 71.0  | 67  | 61  | 72  | 24 | 0.39                            | 350      |
| 1 1/4        | <b>F37-320-CFX</b>     | 30.2 | 58.7  | 68  | 79.0  | 78  | 75  | 82  | 22 | 0.46                            | 280      |
| 1 1/4        | <b>F37-320/38-CFX*</b> | 30.2 | 58.7  | 68  | 79.0  | 78  | 75  | 82  | 22 | 0.46                            | 280      |
| 1 1/2        | <b>F37-324-CFX</b>     | 35.7 | 69.9  | 78  | 93.0  | 90  | 85  | 96  | 25 | 0.68                            | 280      |
| 1 1/2        | <b>F37-324/42-CFX*</b> | 35.7 | 69.9  | 78  | 93.0  | 90  | 85  | 96  | 25 | 0.75                            | 280      |
| 2            | <b>F37-332-CFX</b>     | 42.9 | 77.8  | 97  | 101.5 | 102 | 99  | 104 | 33 | 0.98                            | 280      |
| 2 1/2        | <b>F37-340-CFX</b>     | 50.8 | 88.9  | 109 | 115.5 | 114 | 111 | 117 | 44 | 1.63                            | 210      |
| 3            | <b>F37-348-CFX</b>     | 61.9 | 106.4 | 132 | 135.0 | 136 | 133 | 137 | 50 | 2.79                            | 210      |

**Parflange F37 flange dimensions**

\*Jump size flanges (no adapter sleeves (SL...) necessary)

| Size<br>Inch | Flange<br>Order code    | A    | B    | G   | H     | M   | N   | O   | L  | Thread | Weight<br>(Steel)<br>kg/1 piece | W.P. bar |
|--------------|-------------------------|------|------|-----|-------|-----|-----|-----|----|--------|---------------------------------|----------|
| 3/4          | <b>F37-312T-CFX</b>     | 22.3 | 47.6 | 52  | 65.0  | 61  | 55  | 68  | 20 | M10    | 0.25                            | 350      |
| 1            | <b>F37-316T-CFX</b>     | 26.2 | 52.4 | 60  | 71.0  | 67  | 61  | 72  | 24 | M10    | 0.30                            | 350      |
| 1            | <b>F37-316/30T-CFX*</b> | 26.2 | 52.4 | 60  | 71.0  | 67  | 61  | 72  | 24 | M10    | 0.39                            | 350      |
| 1 1/4        | <b>F37-320T-CFX</b>     | 30.2 | 58.7 | 68  | 79.0  | 78  | 75  | 82  | 22 | M10    | 0.46                            | 280      |
| 1 1/4        | <b>F37-320/38T-CFX*</b> | 30.2 | 58.7 | 68  | 79.0  | 78  | 75  | 82  | 22 | M10    | 0.46                            | 280      |
| 1 1/2        | <b>F37-324T-CFX</b>     | 35.7 | 69.9 | 78  | 93.0  | 90  | 85  | 96  | 25 | M10    | 0.68                            | 280      |
| 2            | <b>F37-332T-CFX</b>     | 42.9 | 77.8 | 97  | 101.5 | 102 | 99  | 104 | 33 | M12    | 0.98                            | 280      |
| 2 1/2        | <b>F37-340T-CFX</b>     | 50.8 | 88.9 | 109 | 115.5 | 114 | 111 | 117 | 44 | M12    | 1.63                            | 210      |

Please change suffixes according to material/surface required

| Order code suffixes             |                                   |              |            |
|---------------------------------|-----------------------------------|--------------|------------|
| Material                        | Suffix<br>surface<br>and material | Example      | Comments   |
| Steel, zinc plated, Cr(VI)-free | CF                                | F37-320-CFX  |            |
| Stainless steel                 | SS                                | F37-320-SSX  |            |
| Galvanized hot dip zinc         | TZN                               | F37-320-TZNX | on request |



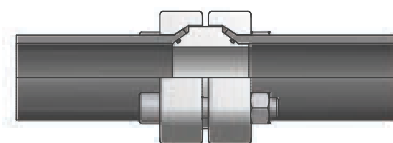

Part combination flaring SAE 3000

| Flange Pressure (bar) | Size Inch | Pipe Size   | Flange SAE 3000 ISO 6162-1 | Insert*         | F37 Seal | Sleeve           | F37 Seal / Flat Face Bonded Seal |                    |                 |
|-----------------------|-----------|-------------|----------------------------|-----------------|----------|------------------|----------------------------------|--------------------|-----------------|
|                       |           |             |                            |                 |          |                  | Bolts Tube to Port               | Bolts Tube to Tube | Nut             |
| 350                   | 1/2       | 16X2.0      | F37-308-CFX                | IN08-16X2.0T... | F37S08X  | SL08-25-16-CFX** | 4 x ZYLS8X35                     | 4 x ZYLS8X55       | 4 x ISO4032-M8  |
|                       | 1/2       | 18X2.0      | F37-308-CFX                | IN08-18X2.0T... | F37S08X  | SL08-25-18-CFX   | 4 x ZYLS8X35                     | 4 x ZYLS8X55       | 4 x ISO4032-M8  |
|                       | 1/2       | 20X2.0      | F37-308-CFX                | IN08-20X2.0T... | F37S08X  | SL08-25-20-CFX   | 4 x ZYLS8X35                     | 4 x ZYLS8X55       | 4 x ISO4032-M8  |
|                       | 1/2       | 20X2.5      | F37-308-CFX                | IN08-20X2.5T... | F37S08X  | SL08-25-20-CFX   | 4 x ZYLS8X35                     | 4 x ZYLS8X55       | 4 x ISO4032-M8  |
|                       | 1/2       | 25X2.5      | F37-308-CFX                | IN08-25X2.5T... | F37S08X  |                  | 4 x ZYLS8X35                     | 4 x ZYLS8X55       | 4 x ISO4032-M8  |
|                       | 1/2       | 25X3.0      | F37-308-CFX                | IN08-25X3.0T... | F37S08X  |                  | 4 x ZYLS8X35                     | 4 x ZYLS8X55       | 4 x ISO4032-M8  |
|                       | 3/4       | 20X2.0      | F37-312-CFX                | IN12-20X2.0T... | F37S12X  | SL12-30-20-CFX   | 4 x ZYLS10X40                    | 4 x ZYLS10X65      | 4 x ISO4032-M10 |
|                       | 3/4       | 20X2.5      | F37-312-CFX                | IN12-20X2.5T... | F37S12X  | SL12-30-20-CFX   | 4 x ZYLS10X40                    | 4 x ZYLS10X65      | 4 x ISO4032-M10 |
|                       | 3/4       | 25X2.5      | F37-312-CFX                | IN12-25X2.5T... | F37S12X  | SL12-30-25-CFX   | 4 x ZYLS10X40                    | 4 x ZYLS10X65      | 4 x ISO4032-M10 |
|                       | 3/4       | 25X3.0      | F37-312-CFX                | IN12-25X3.0T... | F37S12X  | SL12-30-25-CFX   | 4 x ZYLS10X40                    | 4 x ZYLS10X65      | 4 x ISO4032-M10 |
|                       | 3/4       | 30X3.0      | F37-312-CFX                | IN12-30X3.0T... | F37S12X  |                  | 4 x ZYLS10X40                    | 4 x ZYLS10X65      | 4 x ISO4032-M10 |
|                       | 3/4       | 30X4.0      | F37-312-CFX                | IN12-30X4.0T... | F37S12X  |                  | 4 x ZYLS10X40                    | 4 x ZYLS10X65      | 4 x ISO4032-M10 |
|                       | 1         | 25X2.5      | F37-316-CFX                | IN16-25X2.5T... | F37S16X  | SL16-38-25-CFX** | 4 x ZYLS10X45                    | 4 x ZYLS10X75      | 4 x ISO4032-M10 |
|                       | 1         | 25X3.0      | F37-316-CFX                | IN16-25X3.0T... | F37S16X  | SL16-38-25-CFX** | 4 x ZYLS10X45                    | 4 x ZYLS10X75      | 4 x ISO4032-M10 |
|                       | 1         | 30X3.0      | F37-316-CFX                | IN16-30X3.0T... | F37S16X  | SL16-38-30-CFX** | 4 x ZYLS10X45                    | 4 x ZYLS10X75      | 4 x ISO4032-M10 |
|                       | 1         | 30X4.0      | F37-316-CFX                | IN16-30X4.0T... | F37S16X  | SL16-38-30-CFX** | 4 x ZYLS10X45                    | 4 x ZYLS10X75      | 4 x ISO4032-M10 |
|                       | 1         | 38X2.5      | F37-316-CFX                | IN16-38X2.5T... | F37S16X  |                  | 4 x ZYLS10X45                    | 4 x ZYLS10X75      | 4 x ISO4032-M10 |
|                       | 1         | 38X3.0      | F37-316-CFX                | IN16-38X3.0T... | F37S16X  |                  | 4 x ZYLS10X45                    | 4 x ZYLS10X75      | 4 x ISO4032-M10 |
|                       | 1         | 38X4.0      | F37-316-CFX                | IN16-38X4.0T... | F37S16X  |                  | 4 x ZYLS10X45                    | 4 x ZYLS10X75      | 4 x ISO4032-M10 |
|                       | 1         | 38X5.0      | F37-316-CFX                | IN16-38X5.0T... | F37S16X  |                  | 4 x ZYLS10X45                    | 4 x ZYLS10X75      | 4 x ISO4032-M10 |
| 280                   | 1 1/4     | 30X3.0      | F37-320-CFX                | IN20-30X3.0T... | F37S20X  | SL20-42-30-CFX   | 4 x ZYLS10X40                    | 4 x ZYLS10X70      | 4 x ISO4032-M10 |
|                       | 1 1/4     | 30X4.0      | F37-320-CFX                | IN20-30X4.0T... | F37S20X  | SL20-42-30-CFX   | 4 x ZYLS10X40                    | 4 x ZYLS10X70      | 4 x ISO4032-M10 |
|                       | 1 1/4     | 38X3.0      | F37-320-CFX                | IN20-38X3.0T... | F37S20X  | SL20-42-38-CFX   | 4 x ZYLS10X40                    | 4 x ZYLS10X70      | 4 x ISO4032-M10 |
|                       | 1 1/4     | 38X4.0      | F37-320-CFX                | IN20-38X4.0T... | F37S20X  | SL20-42-38-CFX   | 4 x ZYLS10X40                    | 4 x ZYLS10X70      | 4 x ISO4032-M10 |
|                       | 1 1/4     | 38X5.0      | F37-320-CFX                | IN20-38X5.0T... | F37S20X  | SL20-42-38-CFX   | 4 x ZYLS10X40                    | 4 x ZYLS10X70      | 4 x ISO4032-M10 |
|                       | 1 1/4     | 42X3.0      | F37-320-CFX                | IN20-42X3.0T... | F37S20X  |                  | 4 x ZYLS10X40                    | 4 x ZYLS10X70      | 4 x ISO4032-M10 |
|                       | 1 1/4     | 42X4.0      | F37-320-CFX                | IN20-42X4.0T... | F37S20X  |                  | 4 x ZYLS10X40                    | 4 x ZYLS10X70      | 4 x ISO4032-M10 |
|                       | 1 1/2     | 38X3.0      | F37-324-CFX                | IN24-38X3.0T... | F37S24X  | SL24-50-38-CFX   | 4 x ZYLS12X45                    | 4 x ZYLS12X80      | 4 x ISO4032-M12 |
|                       | 1 1/2     | 38X4.0      | F37-324-CFX                | IN24-38X4.0T... | F37S24X  | SL24-50-38-CFX   | 4 x ZYLS12X45                    | 4 x ZYLS12X80      | 4 x ISO4032-M12 |
|                       | 1 1/2     | 38X5.0      | F37-324-CFX                | IN24-38X5.0T... | F37S24X  | SL24-50-38-CFX   | 4 x ZYLS12X45                    | 4 x ZYLS12X80      | 4 x ISO4032-M12 |
|                       | 1 1/2     | 42X3.0      | F37-324-CFX                | IN24-42X3.0T... | F37S24X  | SL24-50-42-CFX** | 4 x ZYLS12X45                    | 4 x ZYLS12X80      | 4 x ISO4032-M12 |
|                       | 1 1/2     | 42X4.0      | F37-324-CFX                | IN24-42X4.0T... | F37S24X  | SL24-50-42-CFX** | 4 x ZYLS12X45                    | 4 x ZYLS12X80      | 4 x ISO4032-M12 |
|                       | 1 1/2     | 50X3.0      | F37-324-CFX                | IN24-50X3.0T... | F37S24X  |                  | 4 x ZYLS12X45                    | 4 x ZYLS12X80      | 4 x ISO4032-M12 |
|                       | 1 1/2     | 50X5.0      | F37-324-CFX                | IN24-50X5.0T... | F37S24X  |                  | 4 x ZYLS12X45                    | 4 x ZYLS12X80      | 4 x ISO4032-M12 |
|                       | 1 1/2     | 50X6.0      | F37-324-CFX                | IN24-50X6.0T... | F37S24X  |                  | 4 x ZYLS12X45                    | 4 x ZYLS12X80      | 4 x ISO4032-M12 |
|                       | 2         | 50X3.0      | F37-332-CFX                | IN32-50X3.0T... | F37S32X  | SL32-60-50-CFX   | 4 x ZYLS12X55                    | 4 x ZYLS12X100     | 4 x ISO4032-M12 |
|                       | 2         | 50X5.0      | F37-332-CFX                | IN32-50X5.0T... | F37S32X  | SL32-60-50-CFX   | 4 x ZYLS12X55                    | 4 x ZYLS12X100     | 4 x ISO4032-M12 |
|                       | 2         | 50X6.0      | F37-332-CFX                | IN32-50X6.0T... | F37S32X  | SL32-60-50-CFX   | 4 x ZYLS12X55                    | 4 x ZYLS12X100     | 4 x ISO4032-M12 |
|                       | 2         | 60X3.0      | F37-332-CFX                | IN32-60X3.0T... | F37S32X  |                  | 4 x ZYLS12X55                    | 4 x ZYLS12X100     | 4 x ISO4032-M12 |
|                       | 2         | 60X5.0      | F37-332-CFX                | IN32-60X5.0T... | F37S32X  |                  | 4 x ZYLS12X55                    | 4 x ZYLS12X100     | 4 x ISO4032-M12 |
| 2                     | 60X6.0    | F37-332-CFX | IN32-60X6.0T...            | F37S32X         |          | 4 x ZYLS12X55    | 4 x ZYLS12X100                   | 4 x ISO4032-M12    |                 |
| 210                   | 2 1/2     | 60X3.0      | F37-340-CFX                | IN40-60X3.0T... | F37S40X  | SL40-75-60-CFX   | 4 x ZYLS12X65                    | 4 x ZYLS12X120     | 4 x ISO4032-M12 |
|                       | 2 1/2     | 60X5.0      | F37-340-CFX                | IN40-60X5.0T... | F37S40X  | SL40-75-60-CFX   | 4 x ZYLS12X65                    | 4 x ZYLS12X120     | 4 x ISO4032-M12 |
|                       | 2 1/2     | 60X6.0      | F37-340-CFX                | IN40-60X6.0T... | F37S40X  | SL40-75-60-CFX   | 4 x ZYLS12X65                    | 4 x ZYLS12X120     | 4 x ISO4032-M12 |
|                       | 2 1/2     | 75X3.0      | F37-340-CFX                | IN40-75X3.0T... | F37S40X  |                  | 4 x ZYLS12X65                    | 4 x ZYLS12X120     | 4 x ISO4032-M12 |
|                       | 2 1/2     | 75X5.0      | F37-340-CFX                | IN40-75X5.0T... | F37S40X  |                  | 4 x ZYLS12X65                    | 4 x ZYLS12X120     | 4 x ISO4032-M12 |
|                       | 3         | 75X3.0      | F37-348-CFX                | IN48-75X3.0T... | F37S48X  | SL48-90-75-CFX   | 4 x ZYLS16X80                    | 4 x ZYLS16X140     | 4 x ISO4032-M16 |
|                       | 3         | 75X5.0      | F37-348-CFX                | IN48-75X5.0T... | F37S48X  | SL48-90-75-CFX   | 4 x ZYLS16X80                    | 4 x ZYLS16X140     | 4 x ISO4032-M16 |
|                       | 3         | 90X3.5      | F37-348-CFX                | IN48-90X3.5T... | F37S48X  |                  | 4 x ZYLS16X80                    | 4 x ZYLS16X140     | 4 x ISO4032-M16 |
|                       | 3         | 90X5.0      | F37-348-CFX                | IN48-90X5.0T... | F37S48X  |                  | 4 x ZYLS16X80                    | 4 x ZYLS16X140     | 4 x ISO4032-M16 |

Select the complete version: \* ...FBCF Bonded Seal version ...FVCF F37 Seal version ...TCF Tube to Tube version ...FCF Flat Face version

\*\*Jump size flanges available alternatively to adapter sleeve, see page 74

Pressure rates related to flanges. Other sizes like schedule on request.

Bolts and nuts are not included in complete part numbers. Bolts and nuts for flanges see page 104



**R – Retaining ring flange | SAE 3000/ISO 6162-1 footprint**

SAE 3000/ISO 6162-1

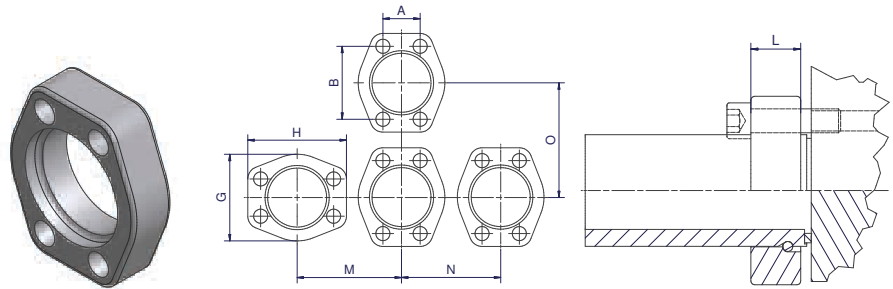

**Retaining ring flange dimensions**

| Size Inch | Order Code       | A    | B     | G   | H     | M   | N   | O   | L  | Weight (Steel) kg/1 piece | W.P. bar |
|-----------|------------------|------|-------|-----|-------|-----|-----|-----|----|---------------------------|----------|
| 1/2       | <b>R-308-CFX</b> | 17.5 | 38.1  | 46  | 54.0  | 52  | 49  | 56  | 19 | 0.2                       | 350      |
| 3/4       | <b>R-312-CFX</b> | 22.3 | 47.6  | 52  | 65.0  | 61  | 55  | 68  | 20 | 0.2                       | 350      |
| 1         | <b>R-316-CFX</b> | 26.2 | 52.4  | 59  | 70.5  | 67  | 61  | 72  | 24 | 0.3                       | 350      |
| 1 1/4     | <b>R-320-CFX</b> | 30.2 | 58.7  | 73  | 80.5  | 78  | 75  | 82  | 22 | 0.5                       | 280      |
| 1 1/2     | <b>R-324-CFX</b> | 35.7 | 69.9  | 83  | 94.5  | 90  | 85  | 96  | 25 | 0.6                       | 280      |
| 2         | <b>R-332-CFX</b> | 42.9 | 77.8  | 97  | 101.5 | 102 | 99  | 104 | 33 | 1.0                       | 280      |
| 2 1/2     | <b>R-340-CFX</b> | 50.8 | 88.9  | 109 | 115.5 | 114 | 111 | 117 | 44 | 1.6                       | 210      |
| 3         | <b>R-348-CFX</b> | 61.9 | 106.4 | 132 | 135.0 | 136 | 133 | 137 | 50 | 2.5                       | 210      |

Please change suffixes according to material/surface required

| Order code suffixes             |                             |            |            |
|---------------------------------|-----------------------------|------------|------------|
| Material                        | Suffix surface and material | Example    | Comments   |
| Steel, zinc plated, Cr(VI)-free | CF                          | R-320-CFX  |            |
| Stainless steel                 | SS                          | R-320-SSX  |            |
| Galvanized hot dip zinc         | TZN                         | R-320-TZNX | on request |

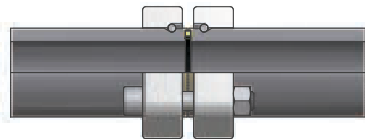

**Part combination Bonded seal SAE 3000 connection**

| Flange pressure (bar) | Size Inch | Pipe Size | Flange    | Retaining Ring | Bonded Seal | Bolts Tube to Port | Bolts Tube to Tube | Nut             |
|-----------------------|-----------|-----------|-----------|----------------|-------------|--------------------|--------------------|-----------------|
| <b>350</b>            | 1/2       | 26X6.0    | R-308-CFX | R08X           | BS08SNX     | 4 x ZYLS8X35       | 4 x ZYLS8X60       | 4 x ISO4032-M8  |
|                       | 3/4       | 36X8.0    | R-312-CFX | R12X           | BS12SNX     | 4 x ZYLS10X40      | 4 x ZYLS10X65      | 4 x ISO4032-M10 |
|                       | 1         | 39X7.5    | R-316-CFX | R16X           | BS16SNX     | 4 x ZYLS10X40      | 4 x ZYLS10X70      | 4 x ISO4032-M10 |
| <b>280</b>            | 1 1/4     | 46X8.0    | R-320-CFX | R20X           | BS20SNX     | 4 x ZYLS10X40      | 4 x ZYLS10X70      | 4 x ISO4032-M10 |
|                       | 1 1/2     | 56X8.5    | R-324-CFX | R24X           | BS24SNX     | 4 x ZYLS12X50      | 4 x ZYLS12X80      | 4 x ISO4032-M12 |
|                       | 2         | 66X8.5    | R-332-CFX | R32X           | BS32SNX     | 4 x ZYLS12X55      | 4 x ZYLS12X90      | 4 x ISO4032-M12 |
| <b>210</b>            | 2 1/2     | 80x10.0   | R-340-CFX | R40X           | BS40SNX     | 4 x ZYLS12X65      | 4 x ZYLS12X120     | 4 x ISO4032-M12 |
|                       | 3         | 97X12.0   | R-348-CFX | R48X           | BS48SNX     | 4 x ZYLS16X80      | 4 x ZYLS16X130     | 4 x ISO4032-M16 |



**PSC – Pipe seal carrier | SAE 3000/ISO 6162-1 footprint**

SAE 3000/ISO 6162-1

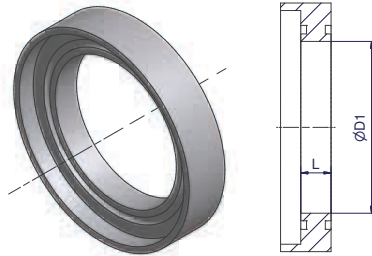

| Size Inch | Pipe size | L    | D1 | Seal carrier    | Flange pressure (bar) |
|-----------|-----------|------|----|-----------------|-----------------------|
| 1 1/2     | 56X8.5    | 10.0 | 49 | on request      | 210                   |
| 2         | 66X8.5    |      |    | PSC32-66X8.5VCF |                       |
| 2 1/2     | 80X10     | 15.0 | 60 | PSC40-80X10VCF  |                       |
| 3         | 97X12     | 15.0 | 73 | PSC48-97X12VCF  |                       |

Other sizes on request  
 Steel PSC incl. seals  
 Stainless steel PSC without seals

Please change suffixes according to material/surface required

| Order code suffixes             |                             |                 |
|---------------------------------|-----------------------------|-----------------|
| Material                        | Suffix surface and material | Example         |
| Steel, zinc plated, Cr(VI)-free | CF                          | PSC40-80X10VCF  |
| Stainless steel                 | SS                          | PSC40-80X10VSSX |

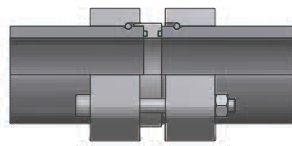

**Part combination Pipe seal carrier SAE 3000 connection**

| Flange pressure (bar) | Size Inch | Pipe Size | Flange    | Retaining Ring | Pipe Seal Carrier | O-Ring           | Bolts Tube to Port | Bolts Tube to Tube | Nut             |
|-----------------------|-----------|-----------|-----------|----------------|-------------------|------------------|--------------------|--------------------|-----------------|
| <b>280</b>            | 1 1/2     | 56X8.5    | R-324-CFX | R24X           | PSC24-56X8.5VCF   | on request       | on request         | on request         | on request      |
|                       | 2         | 66X8.5    | R-332-CFX | R32X           | PSC32-66X8.5VCF   | 2 x OR55.25X2.62 | 4 x ZYLS12X60      | 4 x ZYLS12X100     | 4 x ISO4032-M12 |
| <b>210</b>            | 2 1/2     | 80X10     | R-340-CFX | R40X           | PSC40-80X10VCF    | 2 x OR66.27X3.53 | 4 x ZYLS12X85      | 4 x ZYLS12X125     | 4 x ISO4032-M12 |
|                       | 3         | 97X12     | R-348-CFX | R48X           | PSC48-97X12VCF    | 2 x OR78.97X3.53 | 4 x ZYLS16X100     | 4 x ZYLS16X140     | 4 x ISO4032-M16 |

Other sizes on request

## TFB – Flare connection

Tube to port connection, bonded seal

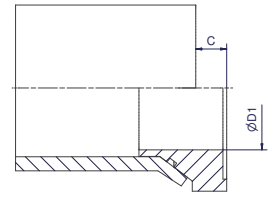
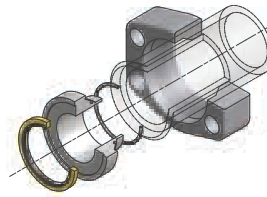

| Size  |        | Flange* incl. Insert +<br>Bonded Seal + O-Ring<br>Order code | D1   | C    | Insert incl.<br>Bonded Seal + O-Ring<br>Order code | Bonded Seal<br>Order code | O-Ring<br>Order code | Weight<br>(Steel)<br>kg/1 piece |
|-------|--------|--|------|------|--|---------------------------|----------------------|---------------------------------|
| Inch  | Tube   |  |      |      |  |                           |                      |                                 |
| 1/2   | 16X2.0 | <b>F37-308-16X2.0TFBCF</b>                                   | 9.5  | 8.0  | IN08-16X2.0TFBCF                                   | BS08SNX                   | OR12X1.0X            | 0.24                            |
| 1/2   | 18X2.0 | <b>F37-308-18X2.0TFBCF</b>                                   | 11.5 | 8.0  | IN08-18X2.0TFBCF                                   | BS08SNX                   | OR14X1.0X            | 0.24                            |
| 1/2   | 20X2.0 | <b>F37-308-20X2.0TFBCF</b>                                   | 13.5 | 8.0  | IN08-20X2.0TFBCF                                   | BS08SNX                   | OR16X1.0X            | 0.24                            |
| 1/2   | 20X2.5 | <b>F37-308-20X2.5TFBCF</b>                                   | 13.5 | 8.0  | IN08-20X2.5TFBCF                                   | BS08SNX                   | OR16X1.0X            | 0.24                            |
| 1/2   | 25X2.5 | <b>F37-308-25X2.5TFBCF</b>                                   | 13.5 | 10.0 | IN08-25X2.5TFBCF                                   | BS08SNX                   | OR20X1.0X            | 0.25                            |
| 1/2   | 25X3.0 | <b>F37-308-25X3.0TFBCF</b>                                   | 13.0 | 8.0  | IN08-25X3.0TFBCF                                   | BS08SNX                   | OR20X1.0X            | 0.24                            |
| 3/4   | 20X2.0 | <b>F37-312-20X2.0TFBCF</b>                                   | 13.5 | 8.0  | IN12-20X2.0TFBCF                                   | BS12SNX                   | OR16X1.0X            | 0.31                            |
| 3/4   | 20X2.5 | <b>F37-312-20X2.5TFBCF</b>                                   | 12.5 | 8.0  | IN12-20X2.5TFBCF                                   | BS12SNX                   | OR16X1.0X            | 0.31                            |
| 3/4   | 25X2.5 | <b>F37-312-25X2.5TFBCF</b>                                   | 17.5 | 10.0 | IN12-25X2.5TFBCF                                   | BS12SNX                   | OR20X1.0X            | 0.31                            |
| 3/4   | 25X3.0 | <b>F37-312-25X3.0TFBCF</b>                                   | 16.5 | 8.0  | IN12-25X3.0TFBCF                                   | BS12SNX                   | OR20X1.0X            | 0.32                            |
| 3/4   | 30X3.0 | <b>F37-312-30X3.0TFBCF</b>                                   | 19.0 | 8.5  | IN12-30X3.0TFBCF                                   | BS12SNX                   | OR25X1.0X            | 0.32                            |
| 3/4   | 30X4.0 | <b>F37-312-30X4.0TFBCF</b>                                   | 19.0 | 8.5  | IN12-30X4.0TFBCF                                   | BS12SNX                   | OR22X1.0X            | 1.32                            |
| 1     | 25X2.5 | <b>F37-316-25X2.5TFBCF</b>                                   | 17.5 | 10.0 | IN16-25X2.5TFBCF                                   | BS16SNX                   | OR20X1.0X            | 0.39                            |
| 1     | 25X3.0 | <b>F37-316-25X3.0TFBCF</b>                                   | 16.5 | 8.0  | IN16-25X3.0TFBCF                                   | BS16SNX                   | OR20X1.0X            | 0.39                            |
| 1     | 30X3.0 | <b>F37-316-30X3.0TFBCF</b>                                   | 21.5 | 8.5  | IN16-30X3.0TFBCF                                   | BS16SNX                   | OR25X1.0X            | 0.39                            |
| 1     | 30X4.0 | <b>F37-316-30X4.0TFBCF</b>                                   | 19.5 | 8.5  | IN16-30X4.0TFBCF                                   | BS16SNX                   | OR22X1.0X            | 0.39                            |
| 1     | 38X2.5 | <b>F37-316-38X2.5TFBCF</b>                                   | 25.0 | 9.5  | IN16-38X2.5TFBCF                                   | BS16SNX                   | OR34X1.0X            | 0.41                            |
| 1     | 38X3.0 | <b>F37-316-38X3.0TFBCF</b>                                   | 25.0 | 9.0  | IN16-38X3.0TFBCF                                   | BS16SNX                   | OR34X1.0X            | 0.40                            |
| 1     | 38X4.0 | <b>F37-316-38X4.0TFBCF</b>                                   | 25.0 | 10.0 | IN16-38X4.0TFBCF                                   | BS16SNX                   | OR30X1.0X            | 0.40                            |
| 1     | 38X5.0 | <b>F37-316-38X5.0TFBCF</b>                                   | 25.0 | 8.0  | IN16-38X5.0TFBCF                                   | BS16SNX                   | OR28X1.0X            | 0.39                            |
| 1 1/4 | 30X3.0 | <b>F37-320-30X3.0TFBCF</b>                                   | 21.5 | 8.5  | IN20-30X3.0TFBCF                                   | BS20SNX                   | OR25X1.0X            | 0.57                            |
| 1 1/4 | 30X4.0 | <b>F37-320-30X4.0TFBCF</b>                                   | 19.5 | 8.5  | IN20-30X4.0TFBCF                                   | BS20SNX                   | OR22X1.0X            | 0.58                            |
| 1 1/4 | 38X3.0 | <b>F37-320-38X3.0TFBCF</b>                                   | 29.5 | 9.0  | IN20-38X3.0TFBCF                                   | BS20SNX                   | OR34X1.0X            | 0.56                            |
| 1 1/4 | 38X4.0 | <b>F37-320-38X4.0TFBCF</b>                                   | 27.0 | 10.0 | IN20-38X4.0TFBCF                                   | BS20SNX                   | OR30X1.0X            | 0.57                            |
| 1 1/4 | 38X5.0 | <b>F37-320-38X5.0TFBCF</b>                                   | 25.5 | 8.0  | IN20-38X5.0TFBCF                                   | BS20SNX                   | OR28X1.0X            | 0.56                            |
| 1 1/4 | 42X3.0 | <b>F37-320-42X3.0TFBCF</b>                                   | 31.5 | 10.0 | IN20-42X3.0TFBCF                                   | BS20SNX                   | OR37.82X1.78X        | 0.57                            |
| 1 1/4 | 42X4.0 | <b>F37-320-42X4.0TFBCF</b>                                   | 31.5 | 10.0 | IN20-42X4.0TFBCF                                   | BS20SNX                   | OR34X1.0X            | 0.56                            |
| 1 1/2 | 38X3.0 | <b>F37-324-38X3.0TFBCF</b>                                   | 27.5 | 9.0  | IN24-38X3.0TFBCF                                   | BS20SNX                   | OR34X1.0X            | 0.65                            |
| 1 1/2 | 38X4.0 | <b>F37-324-38X4.0TFBCF</b>                                   | 27.5 | 10.0 | IN24-38X4.0TFBCF                                   | BS24SNX                   | OR30.X1.0X           | 0.87                            |
| 1 1/2 | 38X5.0 | <b>F37-324-38X5.0TFBCF</b>                                   | 25.0 | 8.0  | IN24-38X5.0TFBCF                                   | BS24SNX                   | OR28X1.0X            | 0.87                            |
| 1 1/2 | 42X3.0 | <b>F37-324-42X3.0TFBCF</b>                                   | 35.0 | 10.0 | IN24-42X3.0TFBCF                                   | BS24SNX                   | OR37.82X1.78X        | 0.88                            |
| 1 1/2 | 42X4.0 | <b>F37-324-42X4.0TFBCF</b>                                   | 31.5 | 10.0 | IN24-42X4.0TFBCF                                   | BS24SNX                   | OR34X1.0X            | 0.87                            |
| 1 1/2 | 50X3.0 | <b>F37-324-50X3.0TFBCF</b>                                   | 36.0 | 11.0 | IN24-50X3.0TFBCF                                   | BS24SNX                   | OR44.17X1.78X        | 0.87                            |
| 1 1/2 | 50X5.0 | <b>F37-324-50X5.0TFBCF</b>                                   | 36.0 | 10.0 | IN24-50X5.0TFBCF                                   | BS24SNX                   | OR41X1.78X           | 0.87                            |
| 1 1/2 | 50X6.0 | <b>F37-324-50X6.0TFBCF</b>                                   | 35.0 | 10.0 | IN24-50X6.0TFBCF                                   | BS24SNX                   | OR41X1.78X           | 0.87                            |
| 2     | 50X3.0 | <b>F37-332-50X3.0TFBCF</b>                                   | 41.5 | 11.0 | IN32-50X3.0TFBCF                                   | BS32SNX                   | OR44.17X1.78X        | 1.20                            |
| 2     | 50X5.0 | <b>F37-332-50X5.0TFBCF</b>                                   | 37.5 | 10.0 | IN32-50X5.0TFBCF                                   | BS32SNX                   | OR41X1.78X           | 1.22                            |
| 2     | 50X6.0 | <b>F37-332-50X6.0TFBCF</b>                                   | 35.0 | 10.0 | IN32-50X6.0TFBCF                                   | BS32SNX                   | OR41X1.78X           | 1.25                            |
| 2     | 60X3.0 | <b>F37-332-60X3.0TFBCF</b>                                   | 46.0 | 12.0 | IN32-60X3.0TFBCF                                   | BS32SNX                   | OR53.7X1.78X         | 1.25                            |
| 2     | 60X5.0 | <b>F37-332-60X5.0TFBCF</b>                                   | 46.0 | 11.0 | IN32-60X5.0TFBCF                                   | BS32SNX                   | OR50.52X1.78X        | 1.22                            |
| 2     | 60X6.0 | <b>F37-332-60X6.0TFBCF</b>                                   | 45.5 | 11.0 | IN32-60X6.0TFBCF                                   | BS32SNX                   | OR47.37X1.78X        | 1.21                            |
| 2 1/2 | 60X3.0 | <b>F37-340-60X3.0TFBCF</b>                                   | 50.0 | 12.0 | IN40-60X3.0TFBCF                                   | BS40SNX                   | OR53.7X1.78X         | 1.98                            |
| 2 1/2 | 60X5.0 | <b>F37-340-60X5.0TFBCF</b>                                   | 46.0 | 11.0 | IN40-60X5.0TFBCF                                   | BS40SNX                   | OR50.52X1.78X        | 1.99                            |
| 2 1/2 | 60X6.0 | <b>F37-340-60X6.0TFBCF</b>                                   | 45.5 | 11.0 | IN40-60X6.0TFBCF                                   | BS40SNX                   | OR47.37X1.78X        | 1.97                            |
| 2 1/2 | 75X3.0 | <b>F37-340-75X3.0TFBCF</b>                                   | 60.0 | 10.0 | IN40-75X3.0TFBCF                                   | BS40SNX                   | OR69.57X1.78X        | 1.93                            |
| 2 1/2 | 75X5.0 | <b>F37-340-75X5.0TFBCF</b>                                   | 60.0 | 10.0 | IN40-75X5.0TFBCF                                   | BS40SNX                   | OR63.22X1.78X        | 1.95                            |
| 3     | 75X3.0 | <b>F37-348-75X3.0TFBCF</b>                                   | 66.0 | 10.0 | IN48-75X3.0TFBCF                                   | BS48SNX                   | OR69.57X1.78X        | 3.22                            |
| 3     | 75X5.0 | <b>F37-348-75X5.0TFBCF</b>                                   | 62.0 | 10.0 | IN48-75X5.0TFBCF                                   | BS48SNX                   | OR63.22X1.78X        | 3.38                            |
| 3     | 90X3.5 | <b>F37-348-90X3.5TFBCF</b>                                   | 72.0 | 15.0 | IN48-90X3.5TFBCF                                   | BS48SNX                   | OR82.27X1.78X        | 3.39                            |
| 3     | 90X5.0 | <b>F37-348-90X5.0TFBCF</b>                                   | 72.0 | 14.0 | IN48-90X5.0TFBCF                                   | BS48SNX                   | OR79X1.78X           | 3.35                            |

Other sizes on request. \*Incl. adapter sleeve or jump size flange if necessary.

Please change suffixes according to material/surface required

| Order code suffixes             |                             |                     |
|---------------------------------|-----------------------------|---------------------|
| Material                        | Suffix surface and material | Example             |
| Steel, zinc plated, Cr(VI)-free | CF                          | F37-324-50X5.0TFBCF |
| Stainless steel                 | SS                          | F37-324-50X5.0TFBSS |



## TFV – Flare flange connection

Tube to port connection, F37 seal

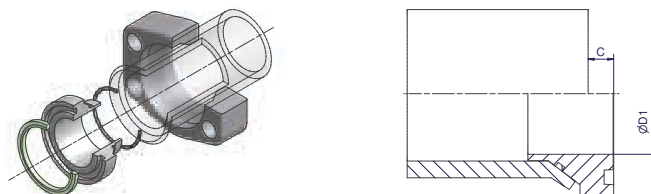

| Size  |        | Flange* incl. Insert +<br>F37 Seal + O-Ring<br>Order code | D1   | C    | Insert incl.<br>F37 Seal + O-Ring<br>Order code | F37 Seal<br>Order code | O-Ring<br>Order code | Weight<br>(Steel)<br>kg/1 piece |
|-------|--------|---|------|------|---|------------------------|----------------------|---------------------------------|
| Inch  | Tube   |   |      |      |   |                        |                      |                                 |
| 1/2   | 16X2.0 | F37-308-16X2.0TFVCF                                       | 9.5  | 8.0  | IN08-16X2.0TFVCF                                | F37S08X                | OR12X1.0X            | 0.24                            |
| 1/2   | 18X2.0 | F37-308-18X2.0TFVCF                                       | 11.5 | 8.0  | IN08-18X2.0TFVCF                                | F37S08X                | OR14X1.1X            | 0.24                            |
| 1/2   | 20X2.0 | F37-308-20X2.0TFVCF                                       | 13.5 | 8.0  | IN08-20X2.0TFVCF                                | F37S08X                | OR16X1.0X            | 0.24                            |
| 1/2   | 20X2.5 | F37-308-20X2.5TFVCF                                       | 13.5 | 8.0  | IN08-20X2.5TFVCF                                | F37S08X                | OR16X1.0X            | 0.24                            |
| 1/2   | 25X2.5 | F37-308-25X2.5TFVCF                                       | 13.5 | 10.0 | IN08-25X2.5TFVCF                                | F37S08X                | OR20X1.0X            | 0.25                            |
| 1/2   | 25X3.0 | F37-308-25X3.0TFVCF                                       | 13.0 | 8.0  | IN08-25X3.0TFVCF                                | F37S08X                | OR20X1.0X            | 0.24                            |
| 3/4   | 20X2.0 | F37-312-20X2.0TFVCF                                       | 13.5 | 8.0  | IN12-20X2.0TFVCF                                | F37S12X                | OR16X1.0X            | 0.31                            |
| 3/4   | 20X2.5 | F37-312-20X2.5TFVCF                                       | 12.5 | 8.0  | IN12-20X2.5TFVCF                                | F37S12X                | OR16X1.0X            | 0.31                            |
| 3/4   | 25X2.5 | F37-312-25X2.5TFVCF                                       | 17.5 | 10.0 | IN12-25X2.5TFVCF                                | F37S12X                | OR20X1.0X            | 0.31                            |
| 3/4   | 25X3.0 | F37-312-25X3.0TFVCF                                       | 16.5 | 8.0  | IN12-25X3.0TFVCF                                | F37S12X                | OR20X1.0X            | 0.32                            |
| 3/4   | 30X3.0 | F37-312-30X3.0TFVCF                                       | 19.0 | 8.5  | IN12-30X3.0TFVCF                                | F37S12X                | OR25X1.0X            | 0.32                            |
| 3/4   | 30X4.0 | F37-312-30X4.0TFVCF                                       | 19.0 | 8.5  | IN12-30X4.0TFVCF                                | F37S12X                | OR22X1.0X            | 0.32                            |
| 1     | 25X2.5 | F37-316-25X2.5TFVCF                                       | 17.5 | 10.0 | IN16-25X2.5TFVCF                                | F37S16X                | OR20X1.0X            | 0.38                            |
| 1     | 25X3.0 | F37-316-25X3.0TFVCF                                       | 16.5 | 8.0  | IN16-25X3.0TFVCF                                | F37S16X                | OR20X1.0X            | 0.39                            |
| 1     | 30X3.0 | F37-316-30X3.0TFVCF                                       | 21.5 | 8.5  | IN16-30X3.0TFVCF                                | F37S16X                | OR25X1.0X            | 0.41                            |
| 1     | 30X4.0 | F37-316-30X4.0TFVCF                                       | 19.5 | 8.5  | IN16-30X4.0TFVCF                                | F37S16X                | OR22X1.0X            | 0.39                            |
| 1     | 38X2.5 | F37-316-38X2.5TFVCF                                       | 25.0 | 9.5  | IN16-38X2.5TFVCF                                | F37S16X                | OR34X1.0X            | 0.41                            |
| 1     | 38X3.0 | F37-316-38X3.0TFVCF                                       | 25.0 | 9.0  | IN16-38X3.0TFVCF                                | F37S16X                | OR34X1.0X            | 0.40                            |
| 1     | 38X4.0 | F37-316-38X4.0TFVCF                                       | 25.0 | 10.0 | IN16-38X4.0TFVCF                                | F37S16X                | OR30X1.0X            | 0.40                            |
| 1     | 38X5.0 | F37-316-38X5.0TFVCF                                       | 25.0 | 8.0  | IN16-38X5.0TFVCF                                | F37S16X                | OR28X1.0X            | 0.39                            |
| 1 1/4 | 30X3.0 | F37-320-30X3.0TFVCF                                       | 21.5 | 8.5  | IN20-30X3.0TFVCF                                | F37S20X                | OR25X1.0X            | 0.57                            |
| 1 1/4 | 30X4.0 | F37-320-30X4.0TFVCF                                       | 19.5 | 8.5  | IN20-30X4.0TFVCF                                | F37S20X                | OR22X1.0X            | 0.58                            |
| 1 1/4 | 38X3.0 | F37-320-38X3.0TFVCF                                       | 29.5 | 9.0  | IN20-38X3.0TFVCF                                | F37S20X                | OR34X1.0X            | 0.56                            |
| 1 1/4 | 38X4.0 | F37-320-38X4.0TFVCF                                       | 27.0 | 10.0 | IN20-38X4.0TFVCF                                | F37S20X                | OR30X1.0X            | 0.57                            |
| 1 1/4 | 38X5.0 | F37-320-38X5.0TFVCF                                       | 25.5 | 8.0  | IN20-38X5.0TFVCF                                | F37S20X                | OR28X1.0X            | 0.56                            |
| 1 1/4 | 42X3.0 | F37-320-42X3.0TFVCF                                       | 31.5 | 10.0 | IN20-42X3.0TFVCF                                | F37S20X                | OR37.82X1.78X        | 0.57                            |
| 1 1/4 | 42X4.0 | F37-320-42X4.0TFVCF                                       | 31.5 | 10.0 | IN20-42X4.0TFVCF                                | F37S20X                | OR34X1.0X            | 0.56                            |
| 1 1/2 | 38X3.0 | F37-324-38X3.0TFVCF                                       | 27.5 | 9.0  | IN24-38X3.0TFVCF                                | F37S24X                | OR34X1.0X            | 0.87                            |
| 1 1/2 | 38X4.0 | F37-324-38X4.0TFVCF                                       | 27.5 | 10.0 | IN24-38X4.0TFVCF                                | F37S24X                | OR30.X1.0X           | 0.87                            |
| 1 1/2 | 38X5.0 | F37-324-38X5.0TFVCF                                       | 25.0 | 8.0  | IN24-38X5.0TFVCF                                | F37S24X                | OR41X1.78X           | 0.87                            |
| 1 1/2 | 42X3.0 | F37-324-42X3.0TFVCF                                       | 33.5 | 10.0 | IN24-42X3.0TFVCF                                | F37S24X                | OR37.82X1.78X        | 0.87                            |
| 1 1/2 | 42X4.0 | F37-324-42X4.0TFVCF                                       | 31.5 | 10.0 | IN24-42X4.0TFVCF                                | F37S24X                | OR34X1.0X            | 0.87                            |
| 1 1/2 | 50X3.0 | F37-324-50X3.0TFVCF                                       | 36.0 | 11.0 | IN24-50X3.0TFVCF                                | F37S24X                | OR44.17X1.78X        | 0.87                            |
| 1 1/2 | 50X5.0 | F37-324-50X5.0TFVCF                                       | 36.0 | 10.0 | IN24-50X5.0TFVCF                                | F37S24X                | OR41X1.78X           | 0.87                            |
| 1 1/2 | 50X6.0 | F37-324-50X6.0TFVCF                                       | 35.0 | 10.0 | IN24-50X6.0TFVCF                                | F37S24X                | OR41X1.78X           | 0.87                            |
| 2     | 50X3.0 | F37-332-50X3.0TFVCF                                       | 41.5 | 11.0 | IN32-50X3.0TFVCF                                | F37S32X                | OR44.17X1.78X        | 1.20                            |
| 2     | 50X5.0 | F37-332-50X5.0TFVCF                                       | 37.5 | 10.0 | IN32-50X5.0TFVCF                                | F37S32X                | OR41X1.78X           | 1.22                            |
| 2     | 50X6.0 | F37-332-50X6.0TFVCF                                       | 35.0 | 10.0 | IN32-50X6.0TFVCF                                | F37S32X                | OR41X1.78X           | 1.25                            |
| 2     | 60X3.0 | F37-332-60X3.0TFVCF                                       | 46.0 | 12.0 | IN32-60X3.0TFVCF                                | F37S32X                | OR53.7X1.78X         | 1.25                            |
| 2     | 60X5.0 | F37-332-60X5.0TFVCF                                       | 46.0 | 11.0 | IN32-60X5.0TFVCF                                | F37S32X                | OR50.52X1.78X        | 1.22                            |
| 2     | 60X6.0 | F37-332-60X6.0TFVCF                                       | 45.5 | 11.0 | IN32-60X6.0TFVCF                                | F37S32X                | OR47.37X1.78X        | 1.21                            |
| 2 1/2 | 60X3.0 | F37-340-60X3.0TFVCF                                       | 50.0 | 12.0 | IN40-60X3.0TFVCF                                | F37S40X                | OR53.7X1.78X         | 1.98                            |
| 2 1/2 | 60X5.0 | F37-340-60X5.0TFVCF                                       | 46.0 | 11.0 | IN40-60X5.0TFVCF                                | F37S40X                | OR50.52X1.78X        | 1.99                            |
| 2 1/2 | 60X6.0 | F37-340-60X6.0TFVCF                                       | 45.5 | 11.0 | IN40-60X6.0TFVCF                                | F37S40X                | OR47.37X1.78X        | 1.97                            |
| 2 1/2 | 75X3.0 | F37-340-75X3.0TFVCF                                       | 60.0 | 10.0 | IN40-75X3.0TFVCF                                | F37S40X                | OR69.57X1.78X        | 1.93                            |
| 2 1/2 | 75X5.0 | F37-340-75X5.0TFVCF                                       | 60.0 | 10.0 | IN40-75X5.0TFVCF                                | F37S40X                | OR63.22X1.78X        | 1.95                            |
| 3     | 75X3.0 | F37-348-75X3.0TFVCF                                       | 66.0 | 10.0 | IN48-75X3.0TFVCF                                | F37S48X                | OR69.57X1.78X        | 3.22                            |
| 3     | 75X5.0 | F37-348-75X5.0TFVCF                                       | 62.0 | 10.0 | IN48-75X5.0TFVCF                                | F37S48X                | OR63.22X1.78X        | 3.38                            |
| 3     | 90X3.5 | F37-348-90X3.5TFVCF                                       | 72.0 | 15.0 | IN48-90X3.5TFVCF                                | F37S48X                | OR82.27X1.78X        | 3.39                            |
| 3     | 90X5.0 | F37-348-90X5.0TFVCF                                       | 72.0 | 14.0 | IN48-90X5.0TFVCF                                | F37S48X                | OR79X1.78X           | 3.35                            |

Other sizes on request. \*Incl. adapter sleeve or jump size flange if necessary.

Please change suffixes according to material/surface required

| Order code suffixes             |                             |                     |
|---------------------------------|-----------------------------|---------------------|
| Material                        | Suffix surface and material | Example             |
| Steel, zinc plated, Cr(VI)-free | CF                          | F37-324-50X5.0TFVCF |
| Stainless steel                 | SS                          | F37-324-50X5.0TFVSS |

**TT – Flare flange connection**

Tube to tube connection

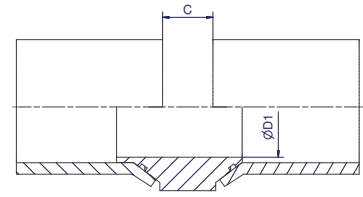
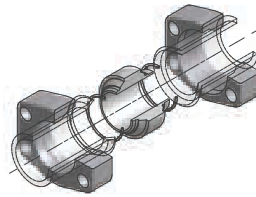

| Size  |        | 2 Flanges* incl. Insert +<br>2 x O-Ring<br>Order code | D1   | C  | Insert incl.<br>2 x O-Ring<br>Order code | O-Ring<br>Order code | Weight<br>(Steel)<br>kg/1 piece |
|-------|--------|---|------|----|--|----------------------|---------------------------------|
| Inch  | Tube   |   |      |    |  |                      |                                 |
| 1/2   | 16X2.0 | <b>F37-308-16X2.0TTCF</b>                             | 9.5  | 16 | IN08-16X2.0TTCF                          | OR12X1.0X            | 0.28                            |
| 1/2   | 18X2.0 | <b>F37-308-18X2.0TTCF</b>                             | 11.5 | 16 | IN08-18X2.0TTCF                          | OR14X1.1X            | 0.29                            |
| 1/2   | 20X2.0 | <b>F37-308-20X2.0TTCF</b>                             | 13.5 | 16 | IN08-20X2.0TTCF                          | OR16X1.0X            | 0.29                            |
| 1/2   | 20X2.5 | <b>F37-308-20X2.5TTCF</b>                             | 13.5 | 16 | IN08-20X2.5TTCF                          | OR16X1.0X            | 0.29                            |
| 1/2   | 25X2.5 | <b>F37-308-25X2.5TTCF</b>                             | 13.5 | 20 | IN08-25X2.5TTCF                          | OR20X1.0X            | 0.30                            |
| 1/2   | 25X3.0 | <b>F37-308-25X3.0TTCF</b>                             | 13.0 | 16 | IN08-25X3.0TTCF                          | OR20X1.0X            | 0.29                            |
| 3/4   | 20X2.0 | <b>F37-312-20X2.0TTCF</b>                             | 13.5 | 16 | IN12-20X2.0TTCF                          | OR16X1.0X            | 0.38                            |
| 3/4   | 20X2.5 | <b>F37-312-20X2.5TTCF</b>                             | 12.5 | 16 | IN12-20X2.5TTCF                          | OR16X1.0X            | 0.38                            |
| 3/4   | 25X2.5 | <b>F37-312-25X2.5TTCF</b>                             | 17.5 | 20 | IN12-25X2.5TTCF                          | OR20X1.0X            | 0.39                            |
| 3/4   | 25X3.0 | <b>F37-312-25X3.0TTCF</b>                             | 16.5 | 16 | IN12-25X3.0TTCF                          | OR20X1.0X            | 0.39                            |
| 3/4   | 30X3.0 | <b>F37-312-30X3.0TTCF</b>                             | 19.0 | 17 | IN12-30X3.0TTCF                          | OR25X1.0X            | 0.40                            |
| 3/4   | 30X4.0 | <b>F37-312-30X4.0TTCF</b>                             | 19.0 | 17 | IN12-30X4.0TTCF                          | OR22X1.0X            | 0.40                            |
| 1     | 25X2.5 | <b>F37-316-25X2.5TTCF</b>                             | 17.5 | 20 | IN16-25X2.5TTCF                          | OR20X1.0X            | 0.49                            |
| 1     | 25X3.0 | <b>F37-316-25X3.0TTCF</b>                             | 16.5 | 16 | IN16-25X3.0TTCF                          | OR20X1.0X            | 0.49                            |
| 1     | 30X3.0 | <b>F37-316-30X3.0TTCF</b>                             | 21.5 | 17 | IN16-30X3.0TTCF                          | OR25X1.0X            | 0.48                            |
| 1     | 30X4.0 | <b>F37-316-30X4.0TTCF</b>                             | 19.5 | 17 | IN16-30X4.0TTCF                          | OR22X1.0X            | 0.49                            |
| 1     | 38X2.5 | <b>F37-316-38X2.5TTCF</b>                             | 25.0 | 19 | IN16-38X2.5TTCF                          | OR34X1.0X            | 0.54                            |
| 1     | 38X3.0 | <b>F37-316-38X3.0TTCF</b>                             | 25.0 | 18 | IN16-38X3.0TTCF                          | OR34X1.0X            | 0.52                            |
| 1     | 38X4.0 | <b>F37-316-38X4.0TTCF</b>                             | 25.0 | 20 | IN16-38X4.0TTCF                          | OR30X1.0X            | 0.50                            |
| 1     | 38X5.0 | <b>F37-316-38X5.0TTCF</b>                             | 25.0 | 16 | IN16-38X5.0TTCF                          | OR28X1.0X            | 0.48                            |
| 1 1/4 | 30X3.0 | <b>F37-320-30X3.0TTCF</b>                             | 21.5 | 17 | IN20-30X3.0TTCF                          | OR25X1.0X            | 0.70                            |
| 1 1/4 | 30X4.0 | <b>F37-320-30X4.0TTCF</b>                             | 19.5 | 17 | IN20-30X4.0TTCF                          | OR22X1.0X            | 0.73                            |
| 1 1/4 | 38X3.0 | <b>F37-320-38X3.0TTCF</b>                             | 29.0 | 18 | IN20-38X3.0TTCF                          | OR34X1.0X            | 0.68                            |
| 1 1/4 | 38X4.0 | <b>F37-320-38X4.0TTCF</b>                             | 27.0 | 20 | IN20-38X4.0TTCF                          | OR30X1.0X            | 0.69                            |
| 1 1/4 | 38X5.0 | <b>F37-320-38X5.0TTCF</b>                             | 25.5 | 16 | IN20-38X5.0TTCF                          | OR28X1.0X            | 0.67                            |
| 1 1/4 | 42X3.0 | <b>F37-320-42X3.0TTCF</b>                             | 31.5 | 20 | IN20-42X3.0TTCF                          | OR37.82X1.78X        | 0.68                            |
| 1 1/4 | 42X4.0 | <b>F37-320-42X4.0TTCF</b>                             | 31.5 | 20 | IN20-42X4.0TTCF                          | OR34X1.0X            | 0.67                            |
| 1 1/2 | 38X3.0 | <b>F37-324-38X3.0TTCF</b>                             | 27.5 | 18 | IN24-38X3.0TTCF                          | OR34X1.0X            | 0.93                            |
| 1 1/2 | 38X4.0 | <b>F37-324-38X4.0TTCF</b>                             | 27.5 | 20 | IN24-38X4.0TTCF                          | OR30.X1.0X           | 0.93                            |
| 1 1/2 | 38X5.0 | <b>F37-324-38X5.0TTCF</b>                             | 25.0 | 16 | IN24-38X5.0TTCF                          | OR41X1.78X           | 0.93                            |
| 1 1/2 | 42X3.0 | <b>F37-324-42X3.0TTCF</b>                             | 33.5 | 20 | IN24-42X3.0TTCF                          | OR37.82X1.78X        | 0.98                            |
| 1 1/2 | 42X4.0 | <b>F37-324-42X4.0TTCF</b>                             | 31.5 | 20 | IN24-42X4.0TTCF                          | OR34X1.0X            | 1.08                            |
| 1 1/2 | 50X3.0 | <b>F37-324-50X3.0TTCF</b>                             | 36.0 | 22 | IN24-50X3.0TTCF                          | OR44.17X1.78X        | 1.10                            |
| 1 1/2 | 50X5.0 | <b>F37-324-50X5.0TTCF</b>                             | 36.0 | 20 | IN24-50X5.0TTCF                          | OR41X1.78X           | 1.21                            |
| 1 1/2 | 50X6.0 | <b>F37-324-50X6.0TTCF</b>                             | 35.0 | 20 | IN24-50X6.0TTCF                          | OR41X1.78X           | 1.10                            |
| 2     | 50X3.0 | <b>F37-332-50X3.0TTCF</b>                             | 41.5 | 22 | IN32-50X3.0TTCF                          | OR44.17X1.78X        | 1.40                            |
| 2     | 50X5.0 | <b>F37-332-50X5.0TTCF</b>                             | 37.5 | 20 | IN32-50X5.0TTCF                          | OR41X1.78X           | 1.51                            |
| 2     | 50X6.0 | <b>F37-332-50X6.0TTCF</b>                             | 35.0 | 20 | IN32-50X6.0TTCF                          | OR41X1.78X           | 1.56                            |
| 2     | 60X3.0 | <b>F37-332-60X3.0TTCF</b>                             | 46.0 | 24 | IN32-60X3.0TTCF                          | OR53.7X1.78X         | 1.53                            |
| 2     | 60X5.0 | <b>F37-332-60X5.0TTCF</b>                             | 46.0 | 22 | IN32-60X5.0TTCF                          | OR50.52X1.78X        | 1.46                            |
| 2     | 60X6.0 | <b>F37-332-60X6.0TTCF</b>                             | 45.5 | 22 | IN32-60X6.0TTCF                          | OR47.37X1.78X        | 1.45                            |
| 2 1/2 | 60X3.0 | <b>F37-340-60X3.0TTCF</b>                             | 50.0 | 24 | IN40-60X3.0TTCF                          | OR53.7X1.78X         | 1.98                            |
| 2 1/2 | 60X5.0 | <b>F37-340-60X5.0TTCF</b>                             | 46.0 | 22 | IN40-60X5.0TTCF                          | OR50.52X1.78X        | 1.99                            |
| 2 1/2 | 60X6.0 | <b>F37-340-60X6.0TTCF</b>                             | 45.0 | 22 | IN40-60X6.0TTCF                          | OR47.37X1.78X        | 1.97                            |
| 2 1/2 | 75X3.0 | <b>F37-340-75X3.0TTCF</b>                             | 60.0 | 20 | IN40-75X3.0TTCF                          | OR69.57X1.78X        | 1.93                            |
| 2 1/2 | 75X5.0 | <b>F37-340-75X5.0TTCF</b>                             | 60.0 | 20 | IN40-75X5.0TTCF                          | OR63.22X1.78X        | 1.95                            |
| 3     | 75X3.0 | <b>F37-348-75X3.0TTCF</b>                             | 66.0 | 20 | IN48-75X3.0TTCF                          | OR69.57X1.78X        | 3.22                            |
| 3     | 75X5.0 | <b>F37-348-75X5.0TTCF</b>                             | 62.0 | 20 | IN48-75X5.0TTCF                          | OR63.22X1.78X        | 3.38                            |
| 3     | 90X3.5 | <b>F37-348-90X3.5TTCF</b>                             | 72.0 | 30 | IN48-90X3.5TTCF                          | OR82.27X1.78X        | 3.39                            |
| 3     | 90X5.0 | <b>F37-348-90X5.0TTCF</b>                             | 72.0 | 28 | IN48-90X5.0TTCF                          | OR79X1.78X           | 3.35                            |

Other sizes on request. \*Incl. adapter sleeve or jump size flange if necessary.

Please change suffixes according to material/surface required

| Order code suffixes             |                             |                    |
|---------------------------------|-----------------------------|--------------------|
| Material                        | Suffix surface and material | Example            |
| Steel, zinc plated, Cr(VI)-free | CF                          | F37-324-50X5.0TTCF |
| Stainless steel                 | SS                          | F37-324-50X5.0TTSS |





**TF – Flare flange connection**

Tube to flange connection, flat face

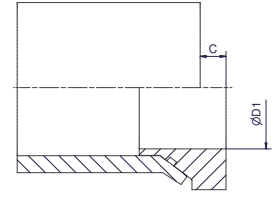
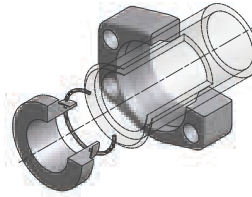

| Size  |        | Flange* incl. Insert +<br>O-Ring<br>Order code | D1   | C    | Insert incl.<br>O-Ring<br>Order code | O-Ring<br>Order code | Weight<br>(Steel)<br>kg/1 piece |
|-------|--------|--|------|------|--------------------------------------|----------------------|---------------------------------|
| Inch  | Tube   |  |      |      |                                      |                      |                                 |
| 1/2   | 16X2.0 | F37-308-16X2.0TFCF                             | 9.5  | 8.0  | IN08-16X2.0TFCF                      | OR12X1.0X            | 0.24                            |
| 1/2   | 18X2.0 | F37-308-18X2.0TFCF                             | 11.5 | 8.0  | IN08-18X2.0TFCF                      | OR14X1.1X            | 0.24                            |
| 1/2   | 20X2.0 | F37-308-20X2.0TFCF                             | 13.5 | 8.0  | IN08-20X2.0TFCF                      | OR16X1.0X            | 0.25                            |
| 1/2   | 20X2.5 | F37-308-20X2.5TFCF                             | 13.5 | 8.0  | IN08-20X2.5TFCF                      | OR16X1.0X            | 0.25                            |
| 1/2   | 25X2.5 | F37-308-25X2.5TFCF                             | 13.5 | 10.0 | IN08-25X2.5TFCF                      | OR20X1.0X            | 0.25                            |
| 1/2   | 25X3.0 | F37-308-25X3.0TFCF                             | 13.0 | 8.0  | IN08-25X3.0TFCF                      | OR20X1.0X            | 0.24                            |
| 3/4   | 20X2.0 | F37-312-20X2.0TFCF                             | 13.5 | 8.0  | IN12-20X2.0TFCF                      | OR16X1.0X            | 0.31                            |
| 3/4   | 20X2.5 | F37-312-20X2.5TFCF                             | 12.5 | 8.0  | IN12-20X2.5TFCF                      | OR16X1.0X            | 0.31                            |
| 3/4   | 25X2.5 | F37-312-25X2.5TFCF                             | 17.5 | 10.0 | IN12-25X2.5TFCF                      | OR20X1.0X            | 0.31                            |
| 3/4   | 25X3.0 | F37-312-25X3.0TFCF                             | 16.5 | 8.0  | IN12-25X3.0TFCF                      | OR20X1.0X            | 0.32                            |
| 3/4   | 30X3.0 | F37-312-30X3.0TFCF                             | 19.0 | 8.5  | IN12-30X3.0TFCF                      | OR25X1.0X            | 0.32                            |
| 3/4   | 30X4.0 | F37-312-30x4.0TFCF                             | 19.0 | 8.5  | IN12-30x4.0TFCF                      | OR22X1.0X            | 0.32                            |
| 1     | 25X2.5 | F37-316-25X2.5TFCF                             | 17.5 | 10.0 | IN16-25X2.5TFCF                      | OR20X1.0X            | 0.38                            |
| 1     | 25X3.0 | F37-316-25X3.0TFCF                             | 16.5 | 8.0  | IN16-25X3.0TFCF                      | OR20X1.0X            | 0.39                            |
| 1     | 30X3.0 | F37-316-30X3.0TFCF                             | 21.5 | 8.5  | IN16-30X3.0TFCF                      | OR25X1.0X            | 0.41                            |
| 1     | 30X4.0 | F37-316-30X4.0TFCF                             | 19.5 | 8.5  | IN16-30X4.0TFCF                      | OR22X1.0X            | 0.39                            |
| 1     | 38X2.5 | F37-316-38X2.5TFCF                             | 25.0 | 9.5  | IN16-38X2.5TFCF                      | OR34X1.0X            | 0.41                            |
| 1     | 38X3.0 | F37-316-38X3.0TFCF                             | 25.0 | 9.0  | IN16-38X3.0TFCF                      | OR34X1.0X            | 0.40                            |
| 1     | 38X4.0 | F37-316-38X4.0TFCF                             | 25.0 | 10.0 | IN16-38X4.0TFCF                      | OR30X1.0X            | 0.40                            |
| 1     | 38X5.0 | F37-316-38X5.0TFCF                             | 25.0 | 8.0  | IN16-38X5.0TFCF                      | OR28X1.0X            | 0.39                            |
| 1 1/4 | 30X3.0 | F37-320-30X3.0TFCF                             | 21.5 | 8.5  | IN20-30X3.0TFCF                      | OR25X1.0X            | 0.57                            |
| 1 1/4 | 30X4.0 | F37-320-30X4.0TFCF                             | 19.5 | 8.5  | IN20-30X4.0TFCF                      | OR22X1.0X            | 0.59                            |
| 1 1/4 | 38X3.0 | F37-320-38X3.0TFCF                             | 29.0 | 9.0  | IN20-38X3.0TFCF                      | OR34X1.0X            | 0.56                            |
| 1 1/4 | 38X4.0 | F37-320-38X4.0TFCF                             | 27.0 | 10.0 | IN20-38X4.0TFCF                      | OR30X1.0X            | 0.57                            |
| 1 1/4 | 38X5.0 | F37-320-38X5.0TFCF                             | 25.5 | 8.0  | IN20-38X5.0TFCF                      | OR28X1.0X            | 0.56                            |
| 1 1/4 | 42X3.0 | F37-320-42X3.0TFCF                             | 31.5 | 10.0 | IN20-42X3.0TFCF                      | OR37.82X1.78X        | 0.57                            |
| 1 1/4 | 42X4.0 | F37-320-42X4.0TFCF                             | 31.5 | 10.0 | IN20-42X4.0TFCF                      | OR34X1.0X            | 0.56                            |
| 1 1/2 | 38X3.0 | F37-324-38X3.0TFCF                             | 27.5 | 9.0  | IN24-38X3.0TFCF                      | OR34X1.0X            | 0.87                            |
| 1 1/2 | 38X4.0 | F37-324-38X4.0TFCF                             | 27.5 | 10.0 | IN24-38X4.0TFCF                      | OR30.X1.0X           | 0.87                            |
| 1 1/2 | 38X5.0 | F37-324-38X5.0TFCF                             | 25.0 | 8.0  | IN24-38X5.0TFCF                      | OR41X1.78X           | 0.87                            |
| 1 1/2 | 42X3.0 | F37-324-42X3.0TFCF                             | 33.5 | 10.0 | IN24-42X3.0TFCF                      | OR37.82X1.78X        | 0.87                            |
| 1 1/2 | 42X4.0 | F37-324-42X4.0TFCF                             | 31.5 | 10.0 | IN24-42X4.0TFCF                      | OR34X1.0X            | 0.87                            |
| 1 1/2 | 50X3.0 | F37-324-50X3.0TFCF                             | 36.0 | 11.0 | IN24-50X3.0TFCF                      | OR44.17X1.78X        | 0.87                            |
| 1 1/2 | 50X5.0 | F37-324-50X5.0TFCF                             | 36.0 | 10.0 | IN24-50X5.0TFCF                      | OR41X1.78X           | 0.87                            |
| 1 1/2 | 50X6.0 | F37-324-50X6.0TFCF                             | 35.0 | 10.0 | IN24-50X6.0TFCF                      | OR41X1.78X           | 0.87                            |
| 2     | 50X3.0 | F37-332-50X3.0TFCF                             | 41.5 | 11.0 | IN32-50X3.0TFCF                      | OR44.17X1.78X        | 1.20                            |
| 2     | 50X5.0 | F37-332-50X5.0TFCF                             | 37.5 | 10.0 | IN32-50X5.0TFCF                      | OR41X1.78X           | 1.22                            |
| 2     | 50X6.0 | F37-332-50X6.0TFCF                             | 35.0 | 10.0 | IN32-50X6.0TFCF                      | OR41X1.78X           | 1.25                            |
| 2     | 60X3.0 | F37-332-60X3.0TFCF                             | 46.0 | 12.0 | IN32-60X3.0TFCF                      | OR53.7X1.78X         | 1.25                            |
| 2     | 60X5.0 | F37-332-60X5.0TFCF                             | 46.0 | 11.0 | IN32-60X5.0TFCF                      | OR50.52X1.78X        | 1.22                            |
| 2     | 60X6.0 | F37-332-60X6.0TFCF                             | 45.5 | 11.0 | IN32-60X6.0TFCF                      | OR47.37X1.78X        | 1.21                            |
| 2 1/2 | 60X3.0 | F37-340-60X3.0TFCF                             | 50.0 | 12.0 | IN40-60X3.0TFCF                      | OR53.7X1.78X         | 1.98                            |
| 2 1/2 | 60X5.0 | F37-340-60X5.0TFCF                             | 46.0 | 11.0 | IN40-60X5.0TFCF                      | OR50.52X1.78X        | 1.99                            |
| 2 1/2 | 60X6.0 | F37-340-60X6.0TFCF                             | 45.5 | 11.0 | IN40-60X6.0TFCF                      | OR47.37X1.78X        | 1.97                            |
| 2 1/2 | 75X3.0 | F37-340-75X3.0TFCF                             | 60.0 | 10.0 | IN40-75X3.0TFCF                      | OR69.57X1.78X        | 1.93                            |
| 2 1/2 | 75X5.0 | F37-340-75X5.0TFCF                             | 60.0 | 10.0 | IN40-75X5.0TFCF                      | OR63.22X1.78X        | 1.95                            |
| 3     | 75X3.0 | F37-348-75X3.0TFCF                             | 66.0 | 10.0 | IN48-75X3.0TFCF                      | OR69.57X1.78X        | 3.22                            |
| 3     | 75X5.0 | F37-348-75X5.0TFCF                             | 62.0 | 10.0 | IN48-75X5.0TFCF                      | OR63.22X1.78X        | 3.38                            |
| 3     | 90X3.5 | F37-348-90X3.5TFCF                             | 72.0 | 15.0 | IN48-90X3.5TFCF                      | OR82.27X1.78X        | 3.39                            |
| 3     | 90X5.0 | F37-348-90X5.0TFCF                             | 72.0 | 14.0 | IN48-90X5.0TFCF                      | OR79X1.78X           | 3.35                            |

Other sizes on request. \*Incl. adapter sleeve or jump size flange if necessary.

Please change suffixes according to material/surface required

| Order code suffixes             |                             |                    |
|---------------------------------|-----------------------------|--------------------|
| Material                        | Suffix surface and material | Example            |
| Steel, zinc plated, Cr(VI)-free | CF                          | F37-324-50X5.0TFCF |
| Stainless steel                 | SS                          | F37-324-50X5.0TFSS |



**SL – Sleeve**

SAE 3000/ISO 6162-1

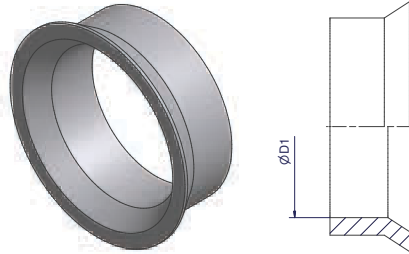

| Size<br>Inch | Tube OD | Order code             | D1    | Weight<br>(Steel)<br>kg/1 piece |
|--------------|---------|------------------------|-------|---------------------------------|
| 1/2          | 16      | <b>SL08-25-16-CFX*</b> | 16.30 | 0.04                            |
| 1/2          | 18      | <b>SL08-25-18-CFX</b>  | 18.30 | 0.04                            |
| 1/2          | 20      | <b>SL08-25-20-CFX</b>  | 20.30 | 0.04                            |
| 3/4          | 20      | <b>SL12-30-20-CFX</b>  | 20.30 | 0.04                            |
| 3/4          | 25      | <b>SL12-30-25-CFX</b>  | 25.20 | 0.04                            |
| 1            | 25      | <b>SL16-38-25-CFX*</b> | 25.20 | 0.04                            |
| 1            | 30      | <b>SL16-38-30-CFX*</b> | 30.20 | 0.04                            |
| 1 1/4        | 30      | <b>SL20-42-30-CFX</b>  | 30.20 | 0.04                            |
| 1 1/4        | 38      | <b>SL20-42-38-CFX*</b> | 38.25 | 0.04                            |
| 1 1/2        | 38      | <b>SL24-50-38-CFX</b>  | 38.25 | 0.14                            |
| 1 1/2        | 42      | <b>SL24-50-42-CFX*</b> | 42.30 | 0.10                            |
| 2            | 50      | <b>SL32-60-50-CFX</b>  | 50.30 | 0.16                            |
| 2 1/2        | 60      | <b>SL40-75-60-CFX</b>  | 60.45 | 0.36                            |
| 3            | 75      | <b>SL48-90-75-CFX</b>  | 75.45 | 0.52                            |

\*By use of jump size flanges, no adapter sleeves necessary. For jump size flanges see page 74.

Please change suffixes according to material/surface required

| Order code suffixes             |                             |                |
|---------------------------------|-----------------------------|----------------|
| Material                        | Suffix surface and material | Example        |
| Steel, zinc plated, Cr(VI)-free | CF                          | SL24-50-42-CFX |
| Stainless steel                 | SS                          | SL24-50-42-SSX |



## R – Retaining ring

SAE 3000/ISO 6162-1

| Size<br>Inch | Tube    | D    | S   | Order code  |
|--------------|---------|------|-----|-------------|
| 1/2          | 26X6.0  | 22.3 | 4.0 | <b>R08X</b> |
| 3/4          | 36X8.0  | 32.3 | 4.0 | <b>R12X</b> |
| 1            | 39X7.5  | 34.3 | 5.0 | <b>R16X</b> |
| 1 1/4        | 46X8.0  | 41.3 | 5.0 | <b>R20X</b> |
| 1 1/2        | 56X8.5  | 51.3 | 5.0 | <b>R24X</b> |
| 2            | 66X8.5  | 61.3 | 5.0 | <b>R32X</b> |
| 2 1/2        | 80X10.0 | 75.3 | 5.0 | <b>R40X</b> |
| 3            | 97X12.0 | 91.3 | 6.0 | <b>R48X</b> |

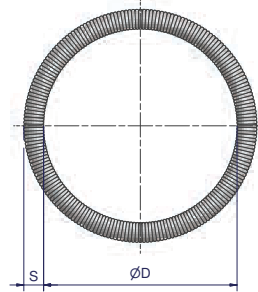

Material: Stainless steel

**MTF-R – Male thread adapter, BSPP**

SAE 3000/ISO 6162-1

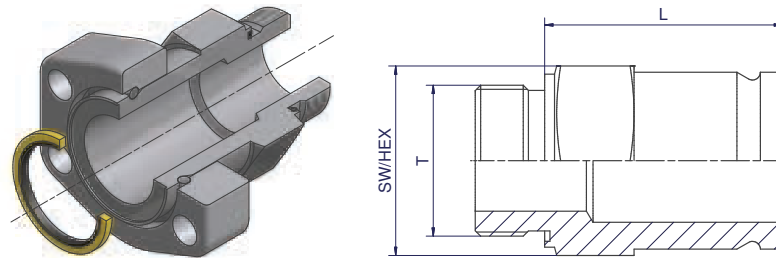

| Size<br>Inch | Tube    | Complete part<br>Order code | Body incl.<br>ED Seal<br>Order code | Weight body<br>(Steel)<br>kg/1 piece | L     | T (BSPP) | SW/<br>HEX |
|--------------|---------|-----------------------------|-------------------------------------|--------------------------------------|-------|----------|------------|
| 3/4          | 36X8.0  | <b>R-312MTFRCF</b>          | MTF12ROMDCF                         | 0.32                                 | 61.0  | G 3/4A   | 36         |
| 3/4          | 36X8.0  | <b>R-312MTFR1/2CF</b>       | MTF12R1/2OMDCF                      | 0.32                                 | 61.0  | G 1/2A   | 36         |
| 1            | 39X7.5  | <b>R-316MTFRCF</b>          | MTF16ROMDCF                         | 0.50                                 | 69.0  | G 1A     | 41         |
| 1            | 39X7.5  | <b>R-316MTFR3/4CF</b>       | MTF16R3/4OMDCF                      | 0.50                                 | 69.0  | G 3/4A   | 41         |
| 1 1/4        | 46X8.0  | <b>R-320MTFRCF</b>          | MTF20ROMDCF                         | 0.75                                 | 80.0  | G 1 1/4A | 50         |
| 1 1/4        | 46X8.0  | <b>R-320MTFR1CF</b>         | MTF20R1OMDCF                        | 0.75                                 | 80.0  | G 1A     | 50         |
| 1 1/2        | 56X8.5  | <b>R-324MTFRCF</b>          | MTF24ROMDCF                         | 1.80                                 | 93.0  | G 1 1/2A | 60         |
| 1 1/2        | 56X8.5  | <b>R-324MTFR11/4CF</b>      | MTF24R11/4OMDCF                     | 1.80                                 | 93.0  | G 1 1/4A | 60         |
| 2            | 66X8.5  | <b>R-332MTFRCF</b>          | MTF32ROMDCF                         | 2.50                                 | 104.0 | G 2A     | 75         |
| 2            | 66X8.5  | <b>R-332MTFR11/2CF</b>      | MTF32R11/2OMDCF                     | 2.50                                 | 104.0 | G 1 1/2A | 75         |
| 2 1/2        | 80X10.0 | <b>R-340MTFRCF</b>          | MTF40ROMDCF                         | 3.50                                 | 134.0 | G 2 1/2A | 85         |
| 2 1/2        | 80X10.0 | <b>R-340MTFR2CF</b>         | MTF40R2OMDCF                        | 3.50                                 | 134.0 | G 2A     | 85         |
| 3            | 97X12.0 | <b>R-348MTFRCF</b>          | MTF48ROMDCF                         | 5.00                                 | 145.0 | G 3A     | 95         |

Other sizes on request

Please change suffixes according to material/surface required

| Order code suffixes             |                             |             |
|---------------------------------|-----------------------------|-------------|
| Material                        | Suffix surface and material | Example     |
| Steel, zinc plated, Cr(VI)-free | CF                          | R-320MTFRCF |
| Stainless steel                 | SS                          | R-320MTFRSS |



**MTF-N – Male thread adapter, NPT**

SAE 3000/ISO 6162-1

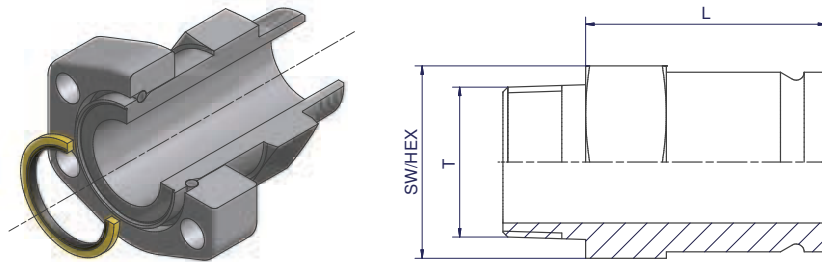

| Size Inch | Tube    | Complete part Order code | Body Order code | Weight body (Steel) kg/1 piece | L     | T (NPT)    | SW/ HEX |
|-----------|---------|--------------------------|-----------------|--------------------------------|-------|------------|---------|
| 1/2       | 26X6.0  | <b>R-308MTFNCF</b>       | MTF08NCFX       | 0.26                           | 72.6  | 1/2-14     | 27      |
| 3/4       | 36X8.0  | <b>R-312MTFNCF</b>       | MTF12NCFX       | 0.48                           | 72.6  | 3/4-14     | 36      |
| 1         | 39X7.5  | <b>R-316MTFNCF</b>       | MTF16NCFX       | 0.45                           | 67.7  | 1-11.5     | 41      |
| 1 1/4     | 46X8.0  | <b>R-320MTFNCF</b>       | MTF20NCFX       | 0.70                           | 75.0  | 1 1/4-11.5 | 50      |
| 1 1/2     | 56X8.5  | <b>R-324MTFNCF</b>       | MTF24NCFX       | 1.80                           | 93.2  | 1 1/2-11.5 | 60      |
| 2         | 66X8.5  | <b>R-332MTFNCF</b>       | MTF32NCFX       | 2.40                           | 100.4 | 2-11.5     | 75      |
| 2 1/2     | 80X10.0 | <b>R-340MTFNCF</b>       | MTF40NCFX       | 2.50                           | 130.0 | 2 1/2-8    | 85      |
| 3         | 97X12.0 | <b>R-348MTFNCF</b>       | MTF48NCFX       | 2.50                           | 141.2 | 3-8        | 95      |

Other sizes on request

Please change suffixes according to material/surface required

| Order code suffixes             |                             |             |
|---------------------------------|-----------------------------|-------------|
| Material                        | Suffix surface and material | Example     |
| Steel, zinc plated, Cr(VI)-free | CF                          | R-320MTFNCF |
| Stainless steel                 | SS                          | R-320MTFNSS |

**FTF-R – Female thread adapter, BSPP**

SAE 3000/ISO 6162-1

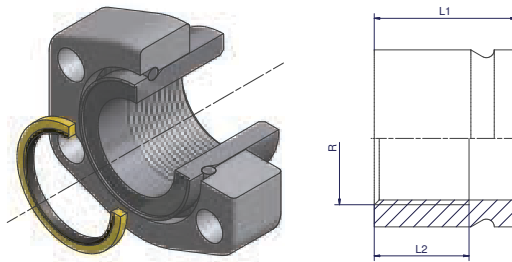

| Size Inch | Tube    | Complete part Order code | Body Order code | Weight body (Steel) kg/1 piece | L1 | L2 | R (BSPP) |
|-----------|---------|--------------------------|-----------------|--------------------------------|----|----|----------|
| 1/2       | 26X6.0  | <b>R-308FTFRCF</b>       | FTF08RCFX       | 0.11                           | 35 | 25 | G 1/4    |
| 3/4       | 36X8.0  | <b>R-312FTFRCF</b>       | FTF12RCFX       | 0.22                           | 40 | 25 | G 1/2    |
| 1         | 39X7.5  | <b>R-316FTFRCF</b>       | FTF16RCFX       | 0.20                           | 40 | 25 | G 3/4    |
| 1 1/4     | 46X8.0  | <b>R-320FTFRCF</b>       | FTF20RCFX       | 0.30                           | 42 | 30 | G 1      |
| 1 1/2     | 56X8.5  | <b>R-324FTFRCF</b>       | FTF24RCFX       | 0.45                           | 45 | 30 | G 1 1/4  |
| 2         | 66X8.5  | <b>R-332FTFRCF</b>       | FTF32RCFX       | 0.75                           | 55 | 40 | G 1 1/2  |
| 2 1/2     | 80X10.0 | <b>R-340FTFRCF</b>       | FTF40RCFX       | 1.52                           | 80 | 40 | G 2      |
| 3         | 97X12.0 | <b>R-348FTFRCF</b>       | FTF48RCFX       | 2.11                           | 85 | 50 | G 2 1/2  |

Other sizes on request

Please change suffixes according to material/surface required



| Order code suffixes             |                             |             |
|---------------------------------|-----------------------------|-------------|
| Material                        | Suffix surface and material | Example     |
| Steel, zinc plated, Cr(VI)-free | CF                          | R-320FTFRCF |
| Stainless steel                 | SS                          | R-320FTFRSS |





## Retaining ring hose couplings

SAE 3000/ISO 6162-1

One Piece No-Skive Hose fittings 48 Series for Parker hose types 301SN (2 wire braid) & 421SN (one wire braid)

|            |       |  |  |  |
|------------|-------|---|--|---|
| Connection |       | Order code  | Order code   | Order code  |
| Flange     | Hose  |   |  |   |
| 1 1/4      | 1 1/4 | <b>1X548-20-20</b>  | <b>1X748-20-20</b>   | <b>1X948-20-20</b>  |
| 1 1/2      | 1 1/2 | <b>1X548-24-24</b>  | <b>1X748-24-24</b>   | <b>1X948-24-24</b>  |
| 2          | 2     | <b>1X548-32-32</b>  | <b>1X748-32-32</b>   | <b>1X948-32-32</b>  |

Interlock Hose nipples V6 series for Parker hose types H82 & R42 (6 spiral)

|            |       |  |  |  |
|------------|-------|--|---|--|
| Connection |       | Order code   | Order code  | Order code   |
| Flange     | Hose  |  |   |  |
| 1 1/4      | 1 1/4 | <b>KX5V6-20-20</b>   | <b>KX7V6-20-20</b>  | <b>KX9V6-20-20</b>   |
| 1 1/2      | 1 1/2 | <b>KX5V6-24-24</b>   | <b>KX7V6-24-24</b>  | <b>KX9V6-24-24</b>   |
| 2          | 2     | <b>KX5V6-32-32</b>   | <b>KX7V6-32-32</b>  | <b>KX9V6-32-32</b>   |

Interlock Shells V6 Series for Parker hose types H82 & R42

|            |  |  |
|------------|--|---|
| Connection |  | Order code  |
| Hose       |  |   |
| 1 1/4      |  | <b>100V6-20</b>   |
| 1 1/2      |  | <b>100V6-24</b>   |
| 2          |  | <b>100V6-32</b>   |



**WA – Weld adapter connection**

SAE 3000/ISO 6162-1

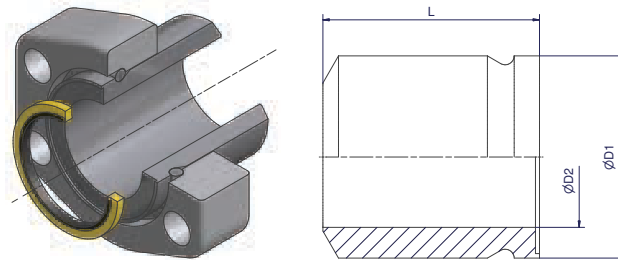

| Size Inch | Tube     | Complete Part Order code | Retaining Ring | Bonded Seal | Flange Order code | Weld Adapter Body Order code | Weight (Steel) kg/1 piece | D1 | D2 | L  |
|-----------|----------|--------------------------|----------------|-------------|-------------------|------------------------------|---------------------------|----|----|----|
| 1/2       | 12X1.5   | <b>R-308WA-12X1.5S</b>   | R08X           | BS08SNX     | R-308-CFX         | WA08-12X1.5SX                | <b>0.29</b>               | 26 | 9  | 40 |
| 1/2       | 16X2.0   | <b>R-308WA-16X2.0S</b>   | R08X           | BS08SNX     | R-308-CFX         | WA08-16X2.0SX                | <b>0.30</b>               | 26 | 12 | 40 |
| 1/2       | 18X2.0   | <b>R-308WA-18X2.0S</b>   | R08X           | BS08SNX     | R-308-CFX         | WA08-18X2.0SX                | <b>0.30</b>               | 26 | 14 | 40 |
| 1/2       | 20X2.0   | <b>R-308WA-20X2.5S</b>   | R08X           | BS08SNX     | R-308-CFX         | WA08-20X2.5SX                | <b>0.30</b>               | 26 | 15 | 40 |
| 1/2       | 21.3X2.1 | <b>R-308WA-21.3X2.1S</b> | R08X           | BS08SNX     | R-308-CFX         | WA08-21.3X2.1SX              | <b>0.30</b>               | 26 | 17 | 40 |
| 1/2       | 21.3X2.8 | <b>R-308WA-21.3X2.8S</b> | R08X           | BS08SNX     | R-308-CFX         | WA08-21.3X2.8SX              | <b>0.30</b>               | 26 | 16 | 40 |
| 1/2       | 21.3X3.7 | <b>R-308WA-21.3X3.7S</b> | R08X           | BS08SNX     | R-308-CFX         | WA08-21.3X3.7SX              | <b>0.31</b>               | 26 | 14 | 45 |
| 1/2       | 21.3X4.8 | <b>R-308WA-21.3X4.8S</b> | R08X           | BS08SNX     | R-308-CFX         | WA08-21.3X4.8SX              | <b>0.32</b>               | 26 | 12 | 45 |
| 1/2       | 21.3X7.5 | <b>R-308WA-21.3X7.5S</b> | R08X           | BS08SNX     | R-308-CFX         | WA08-21.3X7.5SX              | <b>0.32</b>               | 26 | 6  | 45 |
| 1/2       | 25X2.5   | <b>R-308WA-25X2.5S</b>   | R08X           | BS08SNX     | R-308-CFX         | WA08-25X2.5SX                | <b>0.29</b>               | 26 | 14 | 40 |
| 1/2       | 26X6.0   | <b>R-308WA-26X6.0S</b>   | R08X           | BS08SNX     | R-308-CFX         | WA08-26X6.0SX                | <b>0.31</b>               | 26 | 14 | 40 |
| 3/4       | 20X2.5   | <b>R-312WA-20X2.5S</b>   | R12X           | BS12SNX     | R-312-CFX         | WA12-20X2.5SX                | <b>0.41</b>               | 36 | 15 | 45 |
| 3/4       | 25X3.0   | <b>R-312WA-25X3.0S</b>   | R12X           | BS12SNX     | R-312-CFX         | WA12-25X3.0SX                | <b>0.41</b>               | 36 | 19 | 45 |
| 3/4       | 26.7X2.1 | <b>R-312WA-26.7X2.1S</b> | R12X           | BS12SNX     | R-312-CFX         | WA12-26.7X2.1SX              | <b>0.40</b>               | 36 | 20 | 45 |
| 3/4       | 26.7X2.8 | <b>R-312WA-26.7X2.8S</b> | R12X           | BS12SNX     | R-312-CFX         | WA12-26.7X2.8SX              | <b>0.41</b>               | 36 | 20 | 45 |
| 3/4       | 26.7X3.9 | <b>R-312WA-26.7X3.9S</b> | R12X           | BS12SNX     | R-312-CFX         | WA12-26.7X3.9SX              | <b>0.41</b>               | 36 | 19 | 45 |
| 3/4       | 26.7X5.6 | <b>R-312WA-26.7X5.6S</b> | R12X           | BS12SNX     | R-312-CFX         | WA12-26.7X5.6SX              | <b>0.44</b>               | 36 | 16 | 50 |
| 3/4       | 26.7X7.8 | <b>R-312WA-26.7X7.8S</b> | R12X           | BS12SNX     | R-312-CFX         | WA12-26.7X7.8SX              | <b>0.45</b>               | 36 | 11 | 50 |
| 3/4       | 30X3.0   | <b>R-312WA-30X3.0S</b>   | R12X           | BS12SNX     | R-312-CFX         | WA12-30X3.0SX                | <b>0.41</b>               | 36 | 20 | 50 |
| 3/4       | 30X4.0   | <b>R-312WA-30X4.0S</b>   | R12X           | BS12SNX     | R-312-CFX         | WA12-30X4.0SX                | <b>0.42</b>               | 36 | 20 | 50 |
| 3/4       | 30X6.0   | <b>R-312WA-30X6.0S</b>   | R12X           | BS12SNX     | R-312-CFX         | WA12-30X6.0SX                | <b>0.44</b>               | 36 | 18 | 50 |
| 3/4       | 30X8.0   | <b>R-312WA-30X8.0S</b>   | R12X           | BS12SNX     | R-312-CFX         | WA12-30X8.0SX                | <b>0.46</b>               | 36 | 14 | 50 |
| 1         | 25X3.0   | <b>R-316WA-25X3.0S</b>   | R16X           | BS16SNX     | R-316-CFX         | WA16-25X3.0SX                | <b>0.61</b>               | 39 | 19 | 60 |
| 1         | 30X4.0   | <b>R-316WA-30X4.0S</b>   | R16X           | BS16SNX     | R-316-CFX         | WA16-30X4.0SX                | <b>0.60</b>               | 39 | 20 | 60 |
| 1         | 33.4X2.8 | <b>R-316WA-33.4X2.8S</b> | R16X           | BS16SNX     | R-316-CFX         | WA16-33.4X2.8SX              | <b>0.56</b>               | 39 | 24 | 60 |
| 1         | 33.4X3.4 | <b>R-316WA-33.4X3.4S</b> | R16X           | BS16SNX     | R-316-CFX         | WA16-33.4X3.4SX              | <b>0.57</b>               | 39 | 24 | 60 |
| 1         | 33.4X4.6 | <b>R-316WA-33.4X4.6S</b> | R16X           | BS16SNX     | R-316-CFX         | WA16-33.4X4.6SX              | <b>0.59</b>               | 39 | 24 | 60 |
| 1         | 33.4X6.5 | <b>R-316WA-33.4X6.5S</b> | R16X           | BS16SNX     | R-316-CFX         | WA16-33.4X6.5SX              | <b>0.65</b>               | 39 | 20 | 60 |
| 1         | 33.4X9.1 | <b>R-316WA-33.4X9.1S</b> | R16X           | BS16SNX     | R-316-CFX         | WA16-33.4X9.1SX              | <b>0.64</b>               | 39 | 15 | 60 |
| 1         | 38X4.0   | <b>R-316WA-38X4.0S</b>   | R16X           | BS16SNX     | R-316-CFX         | WA16-38X4.0SX                | <b>0.54</b>               | 39 | 24 | 55 |
| 1         | 38X5.0   | <b>R-316WA-38X5.0S</b>   | R16X           | BS16SNX     | R-316-CFX         | WA16-38X5.0SX                | <b>0.56</b>               | 39 | 24 | 55 |
| 1         | 38X7.0   | <b>R-316WA-38X7.0S</b>   | R16X           | BS16SNX     | R-316-CFX         | WA16-38X7.0SX                | <b>0.62</b>               | 39 | 24 | 60 |
| 1         | 39X7.5   | <b>R-316WA-39X7.5S</b>   | R16X           | BS16SNX     | R-316-CFX         | WA16-39X7.5SX                | <b>0.57</b>               | 39 | 24 | 50 |
| 1 1/4     | 30X4.0   | <b>R-320WA-30X4.0S</b>   | R20X           | BS20SNX     | R-320-CFX         | WA20-30X4.0SX                | <b>1.04</b>               | 46 | 22 | 70 |
| 1 1/4     | 38X4.0   | <b>R-320WA-38X4.0S</b>   | R20X           | BS20SNX     | R-320-CFX         | WA20-38X4.0SX                | <b>0.89</b>               | 46 | 30 | 65 |
| 1 1/4     | 38X5.0   | <b>R-320WA-38X5.0S</b>   | R20X           | BS20SNX     | R-320-CFX         | WA20-38X5.0SX                | <b>0.94</b>               | 46 | 28 | 65 |
| 1 1/4     | 42X3.0   | <b>R-320WA-42X3.0S</b>   | R20X           | BS20SNX     | R-320-CFX         | WA20-42X3.0SX                | <b>0.84</b>               | 46 | 30 | 65 |
| 1 1/4     | 42X4.0   | <b>R-320WA-42X4.0S</b>   | R20X           | BS20SNX     | R-320-CFX         | WA20-42X4.0SX                | <b>0.87</b>               | 46 | 30 | 65 |
| 1 1/4     | 42X6.0   | <b>R-320WA-42X6.0S</b>   | R20X           | BS20SNX     | R-320-CFX         | WA20-42X6.0SX                | <b>0.93</b>               | 46 | 30 | 65 |
| 1 1/4     | 42.2X2.7 | <b>R-320WA-42.2X2.7S</b> | R20X           | BS20SNX     | R-320-CFX         | WA20-42.2X2.7SX              | <b>0.83</b>               | 46 | 30 | 65 |
| 1 1/4     | 42.2X3.6 | <b>R-320WA-42.2X3.6S</b> | R20X           | BS20SNX     | R-320-CFX         | WA20-42.2X3.6SX              | <b>0.86</b>               | 46 | 30 | 65 |
| 1 1/4     | 42.2X4.9 | <b>R-320WA-42.2X4.9S</b> | R20X           | BS20SNX     | R-320-CFX         | WA20-42.2X4.9SX              | <b>0.90</b>               | 46 | 30 | 65 |
| 1 1/4     | 42.2X6.4 | <b>R-320WA-42.2X6.4S</b> | R20X           | BS20SNX     | R-320-CFX         | WA20-42.2X6.4SX              | <b>0.94</b>               | 46 | 29 | 65 |
| 1 1/4     | 42.2X9.7 | <b>R-320WA-42.2X9.7S</b> | R20X           | BS20SNX     | R-320-CFX         | WA20-42.2X9.7SX              | <b>1.06</b>               | 46 | 23 | 65 |
| 1 1/4     | 46X7.0   | <b>R-320WA-46X7.0S</b>   | R20X           | BS20SNX     | R-320-CFX         | WA20-46X7.0SX                | <b>0.95</b>               | 46 | 30 | 65 |
| 1 1/4     | 46X8.0   | <b>R-320WA-46X8.0S</b>   | R20X           | BS20SNX     | R-320-CFX         | WA20-46X8.0SX                | <b>0.88</b>               | 46 | 30 | 55 |
| 1 1/2     | 38X5.0   | <b>R-324WA-38X5.0S</b>   | R24X           | BS24SNX     | R-324-CFX         | WA24-38X5.0SX                | <b>1.45</b>               | 56 | 28 | 75 |
| 1 1/2     | 48.3X2.8 | <b>R-324WA-48.3X2.8S</b> | R24X           | BS24SNX     | R-324-CFX         | WA24-48.3X2.8SX              | <b>1.11</b>               | 56 | 39 | 70 |
| 1 1/2     | 48.3X3.7 | <b>R-324WA-48.3X3.7S</b> | R24X           | BS24SNX     | R-324-CFX         | WA24-48.3X3.7SX              | <b>1.15</b>               | 56 | 39 | 70 |
| 1 1/2     | 48.3X5.1 | <b>R-324WA-48.3X5.1S</b> | R24X           | BS24SNX     | R-324-CFX         | WA24-48.3X5.1SX              | <b>1.21</b>               | 56 | 38 | 70 |

see next page



**WA – Weld adapter connection** continued

SAE 3000/ISO 6162-1

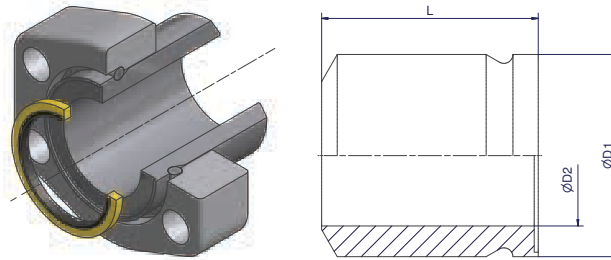

| Size Inch | Tube      | Complete Part Order code  | Retaining Ring | Bonded Seal | Flange Order code | Weld Adapter Body Order code | Weight (Steel) kg/1 piece | D1 | D2 | L   |
|-----------|-----------|---------------------------|----------------|-------------|-------------------|------------------------------|---------------------------|----|----|-----|
| 1 1/2     | 48.3X7.1  | <b>R-324WA-48.3X7.1S</b>  | R24X           | BS24SNX     | R-324-CFX         | WA24-48.3X7.1SX              | 1.33                      | 56 | 34 | 70  |
| 1 1/2     | 48.3X10.2 | <b>R-324WA-48.3X10.2S</b> | R24X           | BS24SNX     | R-324-CFX         | WA24-48.3X10.2SX             | 1.29                      | 56 | 28 | 70  |
| 1 1/2     | 50X3.0    | <b>R-324WA-50X3.0S</b>    | R24X           | BS24SNX     | R-324-CFX         | WA24-50X3.0SX                | 1.10                      | 56 | 39 | 70  |
| 1 1/2     | 50X5.0    | <b>R-324WA-50X5.0S</b>    | R24X           | BS24SNX     | R-324-CFX         | WA24-50X5.0SX                | 1.17                      | 56 | 40 | 70  |
| 1 1/2     | 50X6.0    | <b>R-324WA-50X6.0S</b>    | R24X           | BS24SNX     | R-324-CFX         | WA24-50X6.0SX                | 1.23                      | 56 | 38 | 70  |
| 1 1/2     | 50x9.0    | <b>R-324WA-50X9.0S</b>    | R24X           | BS24SNX     | R-324-CFX         | WA24-50X9.0SX                | 1.39                      | 56 | 32 | 70  |
| 1 1/2     | 56X8.5    | <b>R-324WA-56X8.5S</b>    | R24X           | BS24SNX     | R-324-CFX         | WA24-56X8.5SX                | 1.15                      | 56 | 39 | 60  |
| 2         | 48.3X5.6  | <b>R-332WA-48.3X5.6S</b>  | R32X           | BS32SNX     | R-332-CFX         | WA32-48.3X5.6SX              | 2.30                      | 66 | 37 | 90  |
| 2         | 50X9.0    | <b>R-332WA-50X9.0S</b>    | R32X           | BS32SNX     | R-332-CFX         | WA32-50X9.0SX                | 2.51                      | 66 | 32 | 90  |
| 2         | 60X3.0    | <b>R-332WA-60X3.0S</b>    | R32X           | BS32SNX     | R-332-CFX         | WA32-60X3.0SX                | 1.79                      | 66 | 49 | 90  |
| 2         | 60X5.0    | <b>R-332WA-60X5.0S</b>    | R32X           | BS32SNX     | R-332-CFX         | WA32-60X5.0SX                | 1.89                      | 66 | 50 | 90  |
| 2         | 60X6.0    | <b>R-332WA-60X6.0S</b>    | R32X           | BS32SNX     | R-332-CFX         | WA32-60X6.0SX                | 2.00                      | 66 | 48 | 90  |
| 2         | 60X8.0    | <b>R-332WA-60X8.0S</b>    | R32X           | BS32SNX     | R-332-CFX         | WA32-60X8.0SX                | 2.18                      | 66 | 44 | 90  |
| 2         | 60x10.0   | <b>R-332WA-60X10.0S</b>   | R32X           | BS32SNX     | R-332-CFX         | WA32-60X10.0SX               | 2.36                      | 66 | 40 | 90  |
| 2         | 60.3X2.8  | <b>R-332WA-60.3X2.8S</b>  | R32X           | BS32SNX     | R-332-CFX         | WA32-60.3X2.8SX              | 1.77                      | 66 | 49 | 90  |
| 2         | 60.3X3.9  | <b>R-332WA-60.3X3.9S</b>  | R32X           | BS32SNX     | R-332-CFX         | WA32-60.3X3.9SX              | 1.85                      | 66 | 49 | 90  |
| 2         | 60.3X5.5  | <b>R-332WA-60.3X5.5S</b>  | R32X           | BS32SNX     | R-332-CFX         | WA32-60.3X5.5SX              | 1.94                      | 66 | 49 | 90  |
| 2         | 60.3X8.7  | <b>R-332WA-60.3X8.7S</b>  | R32X           | BS32SNX     | R-332-CFX         | WA32-60.3X8.7SX              | 2.24                      | 66 | 43 | 90  |
| 2         | 60.3X11.1 | <b>R-332WA-60.3X11.1S</b> | R32X           | BS32SNX     | R-332-CFX         | WA32-60.3X11.1SX             | 2.44                      | 66 | 38 | 90  |
| 2         | 66X8.5    | <b>R-332WA-66X8.5S</b>    | R32X           | BS32SNX     | R-332-CFX         | WA32-66X8.5SX                | 1.85                      | 66 | 49 | 75  |
| 2 1/2     | 65X8.5    | <b>R-340WA-65X8.5S</b>    | R40X           | BS40SNX     | R-340-CFX         | WA40-65X8.5SX                | 3.80                      | 80 | 49 | 105 |
| 2 1/2     | 73X7.0    | <b>R-340WA-73X7.0S</b>    | R40X           | BS40SNX     | R-340-CFX         | WA40-73X7.0SX                | 3.29                      | 80 | 59 | 105 |
| 2 1/2     | 75X3.0    | <b>R-340WA-75X3.0S</b>    | R40X           | BS40SNX     | R-340-CFX         | WA40-75X3.0SX                | 2.90                      | 80 | 60 | 105 |
| 2 1/2     | 75X5.0    | <b>R-340WA-75X5.0S</b>    | R40X           | BS40SNX     | R-340-CFX         | WA40-75X5.0SX                | 3.07                      | 80 | 60 | 105 |
| 2 1/2     | 76.1X6.3  | <b>R-340WA-76.1X6.3S</b>  | R40X           | BS40SNX     | R-340-CFX         | WA40-76.1X6.3SX              | 3.15                      | 80 | 60 | 105 |
| 2 1/2     | 76.1X12.5 | <b>R-340WA-76.1X12.5S</b> | R40X           | BS40SNX     | R-340-CFX         | WA40-76.1X12.5SX             | 3.87                      | 80 | 51 | 105 |
| 2 1/2     | 80X10.0   | <b>R-340WA-80X10.0S</b>   | R40X           | BS40SNX     | R-340-CFX         | WA40-80X10.0SX               | 3.10                      | 80 | 60 | 90  |
| 3         | 76.1X12.5 | <b>R-348WA-76.1X12.5S</b> | R48X           | BS48SNX     | R-348-CFX         | WA48-76.1X12.5SX             | 5.68                      | 97 | 51 | 120 |
| 3         | 80X10.0   | <b>R-348WA-80X10.0S</b>   | R48X           | BS48SNX     | R-348-CFX         | WA48-80X10.0SX               | 5.57                      | 97 | 60 | 120 |
| 3         | 88.9X3.1  | <b>R-348WA-88.9X3.1S</b>  | R48X           | BS48SNX     | R-348-CFX         | WA48-88.9X3.1SX              | 4.68                      | 97 | 73 | 120 |
| 3         | 88.9X5.5  | <b>R-348WA-88.9X5.5S</b>  | R48X           | BS48SNX     | R-348-CFX         | WA48-88.9X5.5SX              | 4.97                      | 97 | 73 | 120 |
| 3         | 88.9X7.7  | <b>R-348WA-88.9X7.7S</b>  | R48X           | BS48SNX     | R-348-CFX         | WA48-88.9X7.7SX              | 5.17                      | 97 | 74 | 120 |
| 3         | 88.9X8.8  | <b>R-348WA-88.9X8.8S</b>  | R48X           | BS48SNX     | R-348-CFX         | WA48-88.9X8.8SX              | 5.40                      | 97 | 71 | 120 |
| 3         | 88.9X11.1 | <b>R-348WA-88.9X11.1S</b> | R48X           | BS48SNX     | R-348-CFX         | WA48-88.9X11.1SX             | 5.84                      | 97 | 67 | 120 |
| 3         | 88.9X12.5 | <b>R-348WA-88.9X12.5S</b> | R48X           | BS48SNX     | R-348-CFX         | WA48-88.9X12.5SX             | 6.10                      | 97 | 64 | 120 |
| 3         | 88.9X15.2 | <b>R-348WA-88.9X15.2S</b> | R48X           | BS48SNX     | R-348-CFX         | WA48-88.9X15.2SX             | 6.50                      | 97 | 59 | 120 |
| 3         | 90X3.5    | <b>R-348WA-90X3.5S</b>    | R48X           | BS48SNX     | R-348-CFX         | WA48-90X3.5SX                | 4.69                      | 97 | 73 | 120 |
| 3         | 90X5.0    | <b>R-348WA-90X5.0S</b>    | R48X           | BS48SNX     | R-348-CFX         | WA48-90X5.0SX                | 5.00                      | 97 | 80 | 120 |
| 3         | 90X9.0    | <b>R-348WA-90X9.0S</b>    | R48X           | BS48SNX     | R-348-CFX         | WA48-90X9.0SX                | 5.35                      | 97 | 72 | 120 |
| 3         | 97X12.0   | <b>R-348WA-97X12.0S</b>   | R48X           | BS48SNX     | R-348-CFX         | WA48-97X12.0SX               | 5.15                      | 97 | 73 | 110 |

Other sizes on request

Please change suffixes according to material/surface required

| Order code suffixes |                             |                 |
|---------------------|-----------------------------|-----------------|
| Material            | Suffix surface and material | Example         |
| Steel               | S                           | R-320WA-42X3.0S |
| Stainless steel     | SS                          | R-320WA-42X3.SS |

**BF – Bulkhead flange**

SAE 3000/ISO 6162-1

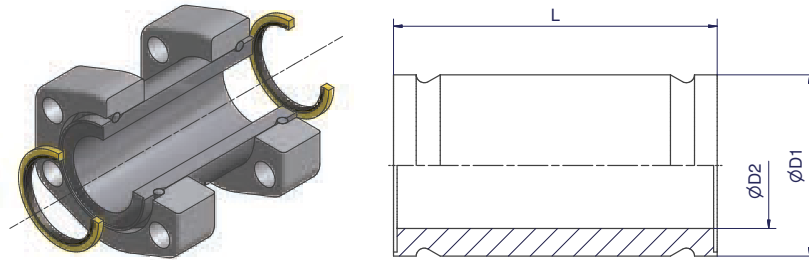

| Size Inch | D1 | D2 | L   | Complete Part Order code | Bulkhead Body Order code | Weight body (Steel) kg/1 piece |
|-----------|----|----|-----|--------------------------|--------------------------|--------------------------------|
| 1         | 39 | 24 | 170 | <b>R-316BFS</b>          | BF16SX                   | 0.96                           |
| 1 1/4     | 46 | 30 | 180 | <b>R-320BFS</b>          | BF20SX                   | 1.30                           |
| 1 1/2     | 56 | 39 | 180 | <b>R-324BFS</b>          | BF24SX                   | 1.75                           |
| 2         | 66 | 49 | 210 | <b>R-332BFS</b>          | BF32SX                   | 2.45                           |
| 2 1/2     | 80 | 60 | 220 | <b>R-340BFS</b>          | BF40SX                   | 3.70                           |
| 3         | 97 | 73 | 240 | <b>R-348BFS</b>          | BF48SX                   | 7.85                           |

Please change suffixes according to material/surface required

| Order code suffixes |                             |           |
|---------------------|-----------------------------|-----------|
| Material            | Suffix surface and material | Example   |
| Steel               | S                           | R-320BFS  |
| Stainless steel     | SS                          | R-320BFSS |



**VB – Vibra bulkhead**

SAE 3000/ISO 6162-1

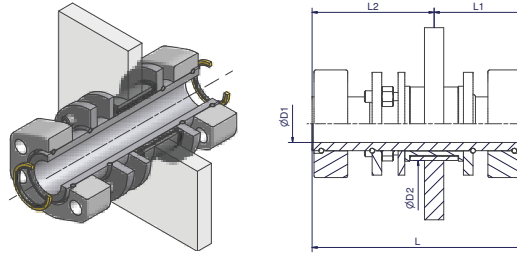

| Size<br>Inch | Complete Part<br>Order code | Tube    | D1 | D2    | L   | L1  | L2  | Weight<br>(Steel)<br>kg/1 piece |
|--------------|-----------------------------|---------|----|-------|-----|-----|-----|---------------------------------|
| 3/4          | <b>R-312VBCF</b>            | 36X8.0  | 20 | 55.5  | 220 | 95  | 125 | 2.90                            |
| 1            | <b>R-316VBCF</b>            | 39X7.5  | 24 | 59.5  | 220 | 95  | 125 | 3.15                            |
| 1 1/4        | <b>R-320VBCF</b>            | 46X8.0  | 30 | 66.5  | 220 | 95  | 125 | 4.10                            |
| 1 1/2        | <b>R-324VBCF</b>            | 56X8.5  | 39 | 76.5  | 220 | 95  | 125 | 4.90                            |
| 2            | <b>R-332VBCF</b>            | 66X8.5  | 49 | 86.5  | 250 | 110 | 140 | 6.19                            |
| 2 1/2        | <b>R-340VBCF</b>            | 80X10.0 | 60 | 100.5 | 260 | 115 | 145 | 9.22                            |
| 3            | <b>R-348VBCF</b>            | 97X12.0 | 73 | 117.5 | 280 | 125 | 155 | 15.32                           |

Other sizes on request

Please change suffixes according to material/surface required

| Order code suffixes             |                                |           |
|---------------------------------|--------------------------------|-----------|
| Material                        | Suffix surface<br>and material | Example   |
| Steel, zinc plated, Cr(VI)-free | CF                             | R-320VBCF |
| Stainless steel                 | SS                             | R-320VBSS |

**RF – Reducer flange**

SAE 3000/ISO 6162-1

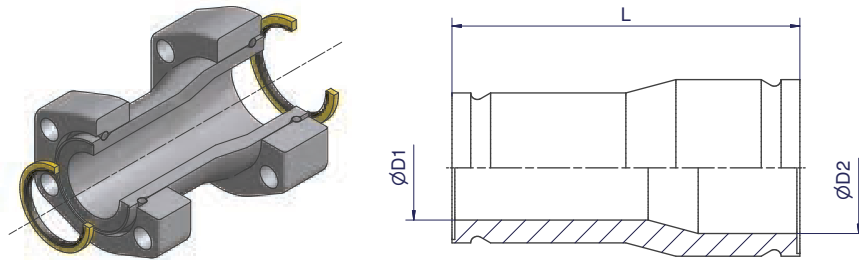

| Size<br>Inch  | Complete Part<br>Order code | Reducer Body<br>Order code | D1 | D2 | L   | Weight body<br>(Steel)<br>kg/1 piece |
|---------------|-----------------------------|----------------------------|----|----|-----|--------------------------------------|
| 1 1/4 - 1     | <b>R-320-316RFCF</b>        | <b>RF20-16CFX</b>          | 24 | 30 | 110 | 0.7                                  |
| 1 1/2 - 1     | <b>R-324-316RFCF</b>        | <b>RF24-16CFX</b>          | 24 | 39 | 115 | 0.9                                  |
| 1 1/2 - 1 1/4 | <b>R-324-320RFCF</b>        | <b>RF24-20CFX</b>          | 30 | 39 | 130 | 1.1                                  |
| 2 - 1 1/4     | <b>R-332-320RFCF</b>        | <b>RF32-20CFX</b>          | 30 | 49 | 130 | 1.3                                  |
| 2 - 1 1/2     | <b>R-332-324RFCF</b>        | <b>RF32-24CFX</b>          | 39 | 49 | 130 | 1.4                                  |
| 2 1/2 - 1 1/2 | <b>R-340-324RFCF</b>        | <b>RF40-24CFX</b>          | 39 | 60 | 150 | 2.1                                  |
| 2 1/2 - 2     | <b>R-340-332RFCF</b>        | <b>RF40-32CFX</b>          | 49 | 60 | 150 | 2.2                                  |
| 3 - 2         | <b>R-348-332RFCF</b>        | <b>RF48-32CFX</b>          | 49 | 73 | 180 | 3.4                                  |
| 3 - 2 1/2     | <b>R-348-340RFCF</b>        | <b>RF48-40CFX</b>          | 60 | 73 | 180 | 3.7                                  |

Other sizes on request

Please change suffixes according to material/surface required

| Order code suffixes             |                             |               |
|---------------------------------|-----------------------------|---------------|
| Material                        | Suffix surface and material | Example       |
| Steel, zinc plated, Cr(VI)-free | CF                          | R-320-316RFCF |
| Stainless steel                 | SS                          | R-320-316RFSS |



## FB90 – 90° Flange bend

SAE 3000/ISO 6162-1

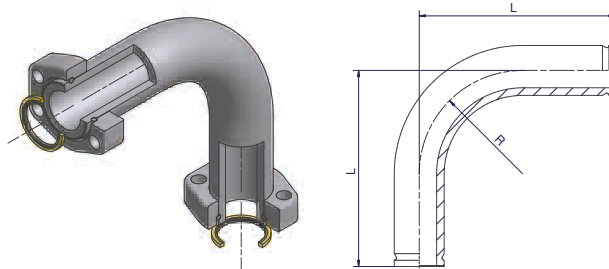

| Size<br>Inch | Complete Part<br>Order code | 90° Flange Bend<br>Order code | Tube    | L   | R   | Weight body<br>(Steel)<br>kg/1 piece |
|--------------|-----------------------------|-------------------------------|---------|-----|-----|--------------------------------------|
| 1            | <b>R-316FB90S</b>           | <b>FB90-16SX</b>              | 39X7.5  | 160 | 98  | 1.59                                 |
| 1 1/4        | <b>R-320FB90S</b>           | <b>FB90-20SX</b>              | 46X8.0  | 180 | 96  | 2.35                                 |
| 1 1/2        | <b>R-324FB90S</b>           | <b>FB90-24SX</b>              | 56X8.5  | 220 | 116 | 3.84                                 |
| 2            | <b>R-332FB90S</b>           | <b>FB90-32SX</b>              | 66X8.5  | 275 | 165 | 5.72                                 |
| 2 1/2        | <b>R-340FB90S</b>           | <b>FB90-40SX</b>              | 80X10.0 | 370 | 200 | 11.20                                |
| 3            | <b>R-348FB90S</b>           | <b>FB90-48SX</b>              | 97X12.0 | 450 | 243 | 19.90                                |

Other sizes on request

Please change suffixes according to material/surface required

| Order code suffixes             |                                |             |            |
|---------------------------------|--------------------------------|-------------|------------|
| Material                        | Suffix surface<br>and material | Example     | Comments   |
| Steel, zinc plated, Cr(VI)-free | SX                             | R-320FB90SX |            |
| Stainless steel                 | SS                             | R-320FB90SS | on request |



**FB45 – 45° Flange bend**

SAE 3000/ISO 6162-1

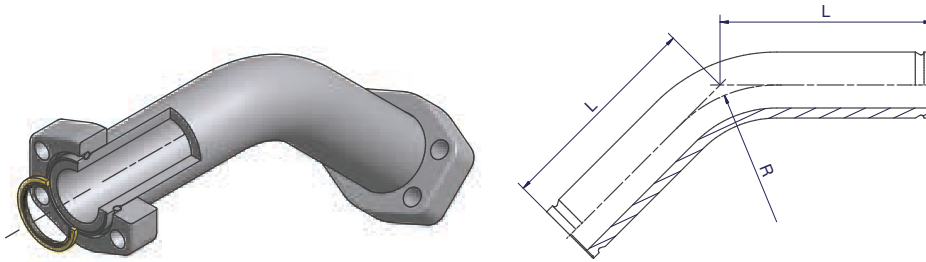

| Size<br>Inch | Complete Part<br>Order code | 45° Flange Bend<br>Order code | Tube    | L   | R   | Weight body<br>(Steel)<br>kg/1 piece |
|--------------|-----------------------------|-------------------------------|---------|-----|-----|--------------------------------------|
| 1            | <b>R-316FB45S</b>           | <b>FB45-16SX</b>              | 39X7.5  | 140 | 80  | 1.58                                 |
| 1 1/4        | <b>R-320FB45S</b>           | <b>FB45-20SX</b>              | 46X8.0  | 150 | 96  | 2.18                                 |
| 1 1/2        | <b>R-324FB45S</b>           | <b>FB45-24SX</b>              | 56X8.5  | 180 | 116 | 3.49                                 |
| 2            | <b>R-332FB45S</b>           | <b>FB45-32SX</b>              | 66X8.5  | 220 | 165 | 5.16                                 |
| 2 1/2        | <b>R-340FB45S</b>           | <b>FB45-40SX</b>              | 80X10.0 | 240 | 200 | 8.07                                 |
| 3            | <b>R-348FB45S</b>           | <b>FB45-48SX</b>              | 97X12.0 | 260 | 243 | 12.70                                |

Available on request

Please change suffixes according to material/surface required

| Order code suffixes             |                                |             |            |
|---------------------------------|--------------------------------|-------------|------------|
| Material                        | Suffix surface<br>and material | Example     | Comments   |
| Steel, zinc plated, Cr(VI)-free | SX                             | FB45-320Sx  |            |
| Stainless steel                 | SS                             | FB45-320SSX | on request |



**FB90 – 90° Flange bend**

SAE 3000/ISO 6162-1

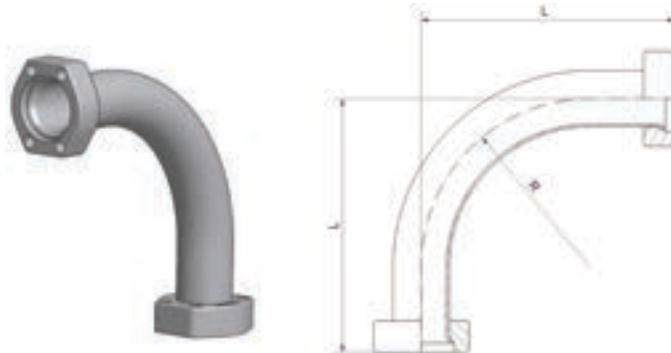

| Size<br>Inch | Tube   | Complete Part<br>Order code | L   | R     | W.P. in bar according to EDIN 2413 (bended pipes)              |  |
|--------------|--------|-----------------------------|-----|-------|--|--|
|              |        |                             |     |       | Tube E355N or E235N - Cr(VI) plated or<br>phosphated and oiled | Seamless Coldrawn Stainless Steel<br>Tube ASTM A269/A213 - AISI 316L |
| 1 1/2        | 50X5   | <b>F37-324FB90</b>          | 220 | 150.0 | 263  | 218  |
| 2            | 60X5   | <b>F37-332FB90</b>          | 275 | 180.0 | 222  | 184  |
| 2 1/2        | 75X5   | <b>F37-340FB90</b>          | 370 | 187.5 | 180  | 149  |
| 3            | 90X3.5 | <b>F37-348FB90</b>          | 450 | 225.0 | 91   | 89   |
| 3            | 90x5   | <b>F37-348905FB90</b>       | 450 | 225.0 | 151  | 126  |

Other sizes on request

Please change suffixes according to material/surface required

| Order code suffixes             |                                |               |
|---------------------------------|--------------------------------|---------------|
| Material                        | Suffix surface<br>and material | Example       |
| Steel, zinc plated, Cr(VI)-free | CF                             | F37-324FB90CF |
| Stainless steel                 | SS                             | F37-324FB90SS |

**FB45 – 45° Flange bend**

SAE 3000/ISO 6162-1



| Size<br>Inch | Tube | Complete Part<br>Order code | L   | R     | W.P. in bar according to EDIN 2413 (bended pipes)              |   |
|--------------|------|-----------------------------|-----|-------|--|---|
|              |      |                             |     |       | Tube E355N or E235N -<br>Cr(VI) plated or phosphated and oiled | Seamless Colddrawn Stainless Steel<br>Tube ASTM A269/A213 - AISI 316L |
| 1 1/2        | 50X5 | <b>F37-324FB45</b>          | 220 | 150.0 | 263  | 218   |
| 2            | 60X5 | <b>F37-332FB45</b>          | 275 | 180.0 | 222  | 184   |
| 2 1/2        | 75X5 | <b>F37-340FB45</b>          | 370 | 187.5 | 180  | 149   |
| 3            | 90X5 | <b>F37-348905FB45</b>       | 370 | 187.5 | 151  | 126   |

Other sizes on request

Please change suffixes according to material/surface required

| Order code suffixes             |                                |               |
|---------------------------------|--------------------------------|---------------|
| Material                        | Suffix surface<br>and material | Example       |
| Steel, zinc plated, Cr(VI)-free | CF                             | F37-324FB45CF |
| Stainless steel                 | SS                             | F37-324FB45SS |



## LF – Elbow flange

SAE 3000/ISO 6162-1

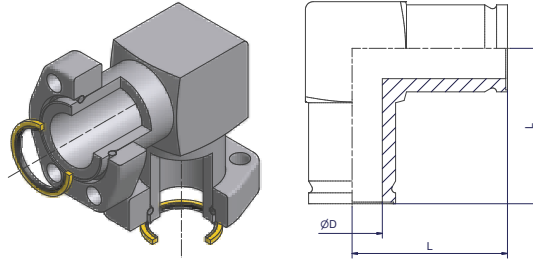

| Size<br>Inch | Complete Part<br>Order code | Elbow Flange<br>body<br>Order code | D  | L   | Weight body<br>(Steel)<br>kg/1 piece |
|--------------|-----------------------------|------------------------------------|----|-----|--------------------------------------|
| 1/2          | <b>R-308LFCF</b>            | <b>LF08CFX</b>                     | 14 | 70  | 0.50                                 |
| 3/4          | <b>R-312LFCF</b>            | <b>LF12CFX</b>                     | 20 | 80  | 1.07                                 |
| 1            | <b>R-316LFCF</b>            | <b>LF16CFX</b>                     | 24 | 85  | 1.32                                 |
| 1 1/4        | <b>R-320LFCF</b>            | <b>LF20CFX</b>                     | 30 | 90  | 1.72                                 |
| 1 1/2        | <b>R-324LFCF</b>            | <b>LF24CFX</b>                     | 39 | 100 | 2.60                                 |
| 2            | <b>R-332LFCF</b>            | <b>LF32CFX</b>                     | 49 | 110 | 4.00                                 |
| 2 1/2        | <b>R-340LFCF</b>            | <b>LF40CFX</b>                     | 60 | 140 | 6.40                                 |
| 3            | <b>R-348LFCF</b>            | <b>LF48CFX</b>                     | 73 | 160 | 10.80                                |

Other sizes on request

Please change suffixes according to material/surface required

| Order code suffixes             |                                |           |
|---------------------------------|--------------------------------|-----------|
| Material                        | Suffix surface<br>and material | Example   |
| Steel, zinc plated, Cr(VI)-free | CF                             | R-320LFCF |
| Stainless steel                 | SS                             | R-320LFSS |

**TF – TEE flange**

SAE 3000/ISO 6162-1

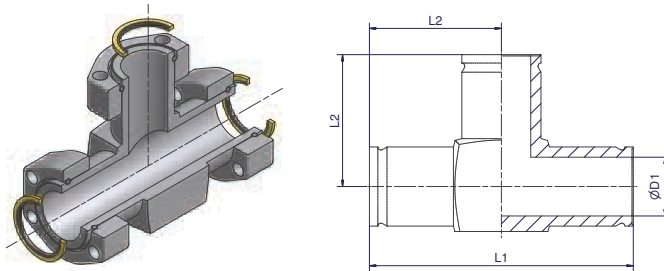

| Size<br>Inch | Complete Part<br>Order code | Tee Flange<br>body<br>Order code | D1 | L1  | L2  | Weight body<br>(Steel)<br>kg/1 piece |
|--------------|-----------------------------|----------------------------------|----|-----|-----|--------------------------------------|
| 1/2          | <b>R-308TFCF</b>            | <b>TF08CFX</b>                   | 14 | 120 | 60  | 0.75                                 |
| 3/4          | <b>R-312TFCF</b>            | <b>TF12CFX</b>                   | 20 | 130 | 65  | 1.60                                 |
| 1            | <b>R-316TFCF</b>            | <b>TF16CFX</b>                   | 24 | 140 | 70  | 2.00                                 |
| 1 1/4        | <b>R-320TFCF</b>            | <b>TF20CFX</b>                   | 30 | 180 | 90  | 2.03                                 |
| 1 1/2        | <b>R-324TFCF</b>            | <b>TF24CFX</b>                   | 39 | 200 | 100 | 3.13                                 |
| 2            | <b>R-332TFCF</b>            | <b>TF32CFX</b>                   | 49 | 220 | 110 | 4.53                                 |
| 2 1/2        | <b>R-340TFCF</b>            | <b>TF40CFX</b>                   | 60 | 260 | 130 | 7.05                                 |
| 3            | <b>R-348TFCF</b>            | <b>TF48CFX</b>                   | 73 | 320 | 160 | 12.81                                |

Other sizes on request

Please change suffixes according to material/surface required

| Order code suffixes             |                             |           |
|---------------------------------|-----------------------------|-----------|
| Material                        | Suffix surface and material | Example   |
| Steel, zinc plated, Cr(VI)-free | CF                          | R-320TFCF |
| Stainless steel                 | SS                          | R-320TFSS |



## LB – Flange L-block

SAE 3000/ISO 6162-1

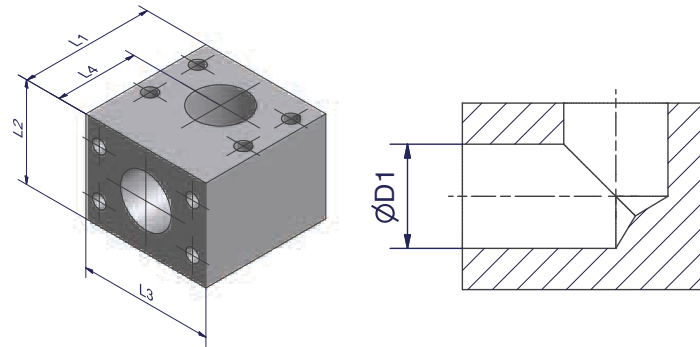

| Size<br>Inch | Order code      | D1 | L1  | L2  | L3  | L4 | Weight (Steel)<br>kg/1 piece |
|--------------|-----------------|----|-----|-----|-----|----|------------------------------|
| 1            | <b>LB316CFX</b> | 25 | 70  | 48  | 70  | 46 | 1.5                          |
| 1 1/4        | <b>LB320CFX</b> | 30 | 80  | 58  | 80  | 51 | 2.4                          |
| 1 1/2        | <b>LB324CFX</b> | 38 | 90  | 68  | 90  | 56 | 3.4                          |
| 2            | <b>LB332CFX</b> | 50 | 96  | 78  | 100 | 57 | 4.4                          |
| 2 1/2        | <b>LB340CFX</b> | 60 | 110 | 88  | 110 | 65 | 6.0                          |
| 3            | <b>LB348CFX</b> | 73 | 135 | 110 | 135 | 80 | 11.3                         |

Other sizes on request

Please change suffixes according to material/surface required

| Order code suffixes             |                                   |          |
|---------------------------------|-----------------------------------|----------|
| Material                        | Suffix<br>surface<br>and material | Example  |
| Steel, zinc plated, Cr(VI)-free | CF                                | LB320CFX |
| Stainless steel                 | SS                                | LB320SSX |

**LBR – Flange L-block reducer**

SAE 3000/ISO 6162-1

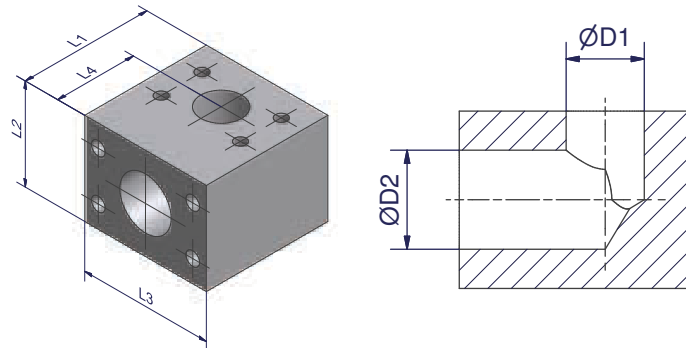

| Size<br>Inch  | Order code           | D1 | D2 | L1 | L2 | L3  | L4 | Weight (Steel)<br>kg/1 piece |
|---------------|----------------------|----|----|----|----|-----|----|------------------------------|
| 1 1/4 - 1     | <b>LBR320-316CFX</b> | 25 | 30 | 80 | 58 | 80  | 51 | 2.4                          |
| 1 1/2 - 1     | <b>LBR324-316CFX</b> | 25 | 38 | 90 | 68 | 90  | 56 | 3.6                          |
| 1 1/2 - 1 1/4 | <b>LBR324-320CFX</b> | 30 | 38 | 90 | 68 | 90  | 56 | 3.6                          |
| 2 - 1         | <b>LBR332-316CFX</b> | 25 | 50 | 96 | 78 | 100 | 57 | 4.7                          |
| 2 - 1 1/4     | <b>LBR332-320CFX</b> | 30 | 50 | 96 | 78 | 100 | 57 | 4.7                          |
| 2 - 1 1/2     | <b>LBR332-324CFX</b> | 38 | 50 | 96 | 78 | 100 | 57 | 4.6                          |

Other sizes on request

Please change suffixes according to material/surface required

| Order code suffixes             |                                   |               |
|---------------------------------|-----------------------------------|---------------|
| Material                        | Suffix<br>surface<br>and material | Example       |
| Steel, zinc plated, Cr(VI)-free | CF                                | LBR320-316CFX |
| Stainless steel                 | SS                                | LBR320-316SSX |





## TB – Flange T-block

SAE 3000/ISO 6162-1

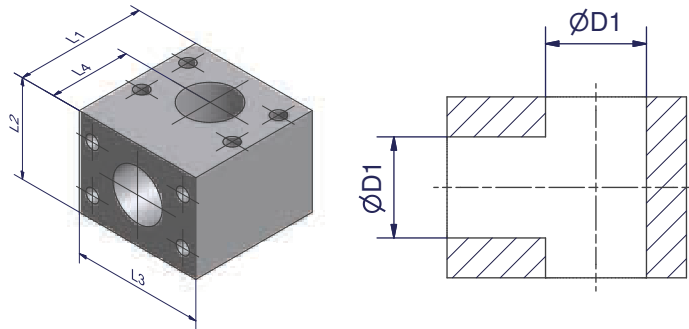

| Size<br>Inch | Order code      | D1 | L1  | L2  | L3  | L4 | Weight (Steel)<br>kg/1 piece |
|--------------|-----------------|----|-----|-----|-----|----|------------------------------|
| 1/2          | <b>TB308CFX</b> | 13 | 60  | 50  | 60  | 37 | 1.2                          |
| 3/4          | <b>TB312CFX</b> | 19 | 68  | 55  | 66  | 44 | 1.6                          |
| 1            | <b>TB316CFX</b> | 25 | 70  | 55  | 70  | 46 | 1.6                          |
| 1 1/4        | <b>TB320CFX</b> | 30 | 80  | 58  | 80  | 51 | 2.2                          |
| 1 1/2        | <b>TB324CFX</b> | 38 | 90  | 68  | 90  | 56 | 3.1                          |
| 2            | <b>TB332CFX</b> | 50 | 96  | 78  | 100 | 57 | 3.9                          |
| 2 1/2        | <b>TB340CFX</b> | 60 | 110 | 88  | 110 | 65 | 5.3                          |
| 3            | <b>TB348CFX</b> | 73 | 135 | 110 | 135 | 80 | 10.0                         |

Other sizes on request

Please change suffixes according to material/surface required

| Order code suffixes             |                                   |          |
|---------------------------------|-----------------------------------|----------|
| Material                        | Suffix<br>surface<br>and material | Example  |
| Steel, zinc plated, Cr(VI)-free | CF                                | TB320CFX |
| Stainless steel                 | SS                                | TB320SSX |

**TBR – Flange T-block reducer**

SAE 3000/ISO 6162-1

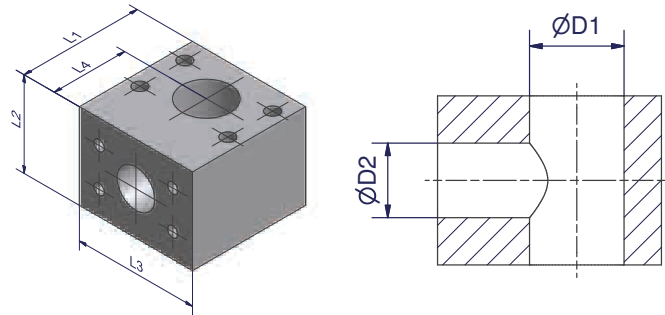

| Size Inch             | Order code               | D1 | D2 | L1  | L2  | L3  | L4 | Weight (Steel) kg/1 piece |
|-----------------------|--------------------------|----|----|-----|-----|-----|----|---------------------------|
| 1 1/4 - 1 - 1 1/4     | <b>TBR320-316-320CFX</b> | 30 | 25 | 80  | 58  | 80  | 51 | 2.3                       |
| 1 1/2 - 1 1/4 - 1 1/2 | <b>TBR324-320-324CFX</b> | 38 | 30 | 90  | 68  | 90  | 56 | 3.3                       |
| 1 1/2 - 1 - 1 1/2     | <b>TBR324-316-324CFX</b> | 38 | 25 | 90  | 68  | 90  | 56 | 3.4                       |
| 2 - 1 1/2 - 2         | <b>TBR332-324-332CFX</b> | 50 | 38 | 96  | 78  | 100 | 57 | 4.2                       |
| 2 - 1 1/4 - 2         | <b>TBR332-320-332CFX</b> | 50 | 30 | 96  | 78  | 100 | 57 | 4.3                       |
| 2 1/2 - 2 - 2 1/2     | <b>TBR340-332-340CFX</b> | 60 | 50 | 110 | 88  | 110 | 65 | 5.6                       |
| 2 1/2 - 1 1/2 - 2 1/2 | <b>TBR340-324-340CFX</b> | 60 | 38 | 110 | 88  | 110 | 65 | 5.9                       |
| 3 - 2 1/2 - 3         | <b>TBR348-340-348CFX</b> | 73 | 60 | 135 | 110 | 135 | 80 | 10.6                      |
| 3 - 2 - 3             | <b>TBR348-332-348CFX</b> | 73 | 50 | 135 | 110 | 135 | 80 | 11.0                      |

Other sizes on request

Please change suffixes according to material/surface required

| Order code suffixes             |                             |                   |
|---------------------------------|-----------------------------|-------------------|
| Material                        | Suffix surface and material | Example           |
| Steel, zinc plated, Cr(VI)-free | CF                          | TBR320-316-320CFX |
| Stainless steel                 | SS                          | TBR320-316-320SSX |



## BFV – Blind flange

SAE 3000/ISO 6162-1

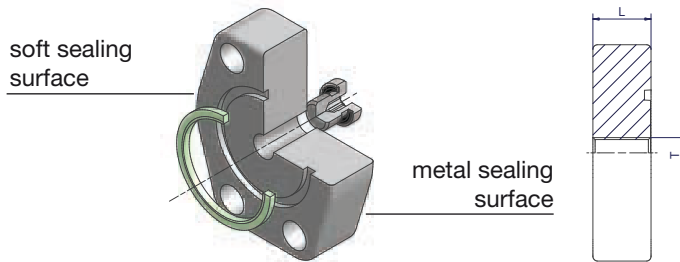

| Size<br>Inch | L  | T     | Weight (Steel)<br>kg/1 piece | Flange incl.<br>VSTI-ED and F37 Seal<br>Order code |
|--------------|----|-------|------------------------------|--|
| 1            | 24 | G 1/4 | 0.60                         | <b>F37-316BFVCF</b>                                |
| 1 1/4        | 22 | G 1/4 | 0.70                         | <b>F37-320BFVCF</b>                                |
| 1 1/2        | 25 | G 1/4 | 1.10                         | <b>F37-324BFVCF</b>                                |
| 2            | 33 | G 1/4 | 2.00                         | <b>F37-332BFVCF</b>                                |
| 2 1/2        | 44 | G 1/4 | 3.45                         | <b>F37-340BFVCF</b>                                |
| 3            | 50 | G 1/4 | 5.45                         | <b>F37-348BFVCF</b>                                |

Please change suffixes according to material/surface required

| Order code suffixes             |                             |              |
|---------------------------------|-----------------------------|--------------|
| Material                        | Suffix surface and material | Example      |
| Steel, zinc plated, Cr(VI)-free | CF                          | F37-320BFVCF |
| Stainless steel                 | SS                          | F37-320BFVSS |

**BS – Bonded seal**

SAE 3000/ISO 6162-1

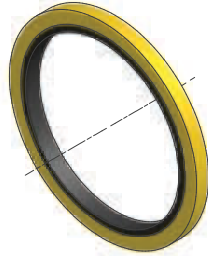

| Size<br>Inch | Steel          | Stainless Steel |
|--------------|----------------|-----------------|
| 1/2          | <b>BS08SNX</b> | <b>BS08SSNX</b> |
| 3/4          | <b>BS12SNX</b> | <b>BS12SSNX</b> |
| 1            | <b>BS16SNX</b> | <b>BS16SSNX</b> |
| 1 1/4        | <b>BS20SNX</b> | <b>BS20SSNX</b> |
| 1 1/2        | <b>BS24SNX</b> | <b>BS24SSNX</b> |
| 2            | <b>BS32SNX</b> | <b>BS32SSNX</b> |
| 2 1/2        | <b>BS40SNX</b> | <b>BS40SSNX</b> |
| 3            | <b>BS48SNX</b> | <b>BS48SSNX</b> |

Sealing: NBR  
Other sealing materials like FKM on request

**F37S – F37 seal**

SAE 3000/ISO 6162-1

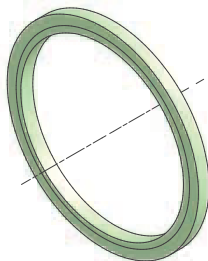

| Size<br>Inch | F37 Seal       |
|--------------|----------------|
| 1/2          | <b>F37S08X</b> |
| 3/4          | <b>F37S12X</b> |
| 1            | <b>F37S16X</b> |
| 1 1/4        | <b>F37S20X</b> |
| 1 1/2        | <b>F37S24X</b> |
| 2            | <b>F37S32X</b> |
| 2 1/2        | <b>F37S40X</b> |
| 3            | <b>F37S48X</b> |

Sealing: Polyurethane  
Material properties and applications see page 18



**AO – Adapter bonded seal to F37 seal/O-Ring**

SAE 3000/ISO 6162-1

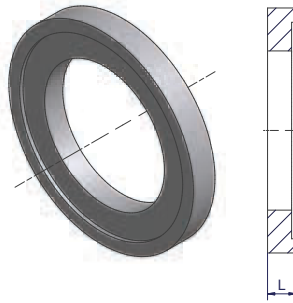

| Size<br>Inch | L | Weight (Steel)<br>kg/1 piece | Adapter<br>Order code |
|--------------|---|------------------------------|-----------------------|
| 1/2          | 5 | 0.01                         | <b>AO08CFX</b>        |
| 3/4          | 5 | 0.02                         | <b>AO12CFX</b>        |
| 1            | 7 | 0.06                         | <b>AO16CFX</b>        |
| 1 1/4        | 7 | 0.06                         | <b>AO20CFX</b>        |
| 1 1/2        | 7 | 0.08                         | <b>AO24CFX</b>        |
| 2            | 7 | 0.10                         | <b>AO32CFX</b>        |
| 2 1/2        | 7 | 0.14                         | <b>AO40CFX</b>        |
| 3            | 7 | 0.20                         | <b>AO48CFX</b>        |

Please change suffixes according to material/surface required

| Order code suffixes             |                             |         |
|---------------------------------|-----------------------------|---------|
| Material                        | Suffix surface and material | Example |
| Steel, zinc plated, Cr(VI)-free | CF                          | AO32CFX |
| Stainless steel                 | SS                          | AO32SSX |

**TBT – TEE between bonded seal**

SAE 3000/ISO 6162-1

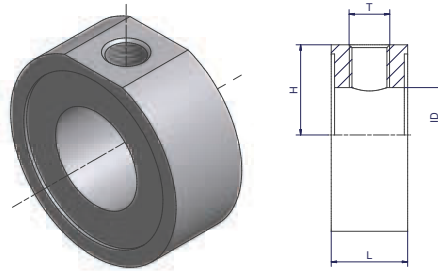

| Size<br>Inch | Order code*         | L  | H    | T       | ID | Bolt ISO 4762 | Weight body<br>(Steel)<br>kg/1 piece |
|--------------|---------------------|----|------|---------|----|---------------|--------------------------------------|
| 1            | <b>TBT16-1/4CFX</b> | 25 | 20.5 | G 1/4 A | 25 | ZYLS10X90     | 0.21                                 |
| 1 1/4        | <b>TBT20-1/4CFX</b> | 25 | 24.5 | G 1/4 A | 27 | ZYLS10X100    | 0.30                                 |
| 1 1/4        | <b>TBT20-1/2CFX</b> | 40 | 22.5 | G 1/2 A | 24 | ZYLS10X120    | 0.49                                 |
| 1 1/2        | <b>TBT24-1/4CFX</b> | 25 | 29.5 | G 1/4 A | 31 | ZYLS12X110    | 0.42                                 |
| 1 1/2        | <b>TBT24-1/2CFX</b> | 40 | 28.0 | G 1/2 A | 30 | ZYLS12X130    | 0.68                                 |
| 2            | <b>TBT32-1/4CFX</b> | 25 | 35.0 | G 1/4 A | 41 | ZYLS12X110    | 0.51                                 |
| 2            | <b>TBT32-1/2CFX</b> | 40 | 34.0 | G 1/2 A | 38 | ZYLS12X130    | 0.87                                 |
| 2 1/2        | <b>TBT40-1/4CFX</b> | 30 | 41.5 | G 1/4 A | 60 | ZYLS12X150    | 0.63                                 |
| 3            | <b>TBT48-1/4CFX</b> | 30 | 50.0 | G 1/4 A | 72 | ZYLS12X150    | 0.90                                 |

\*For testpoints and diagnostic test equipment see catalogue 4100, Industrial Tube Fittings Europe

Alternative versions on request



**TFVB**

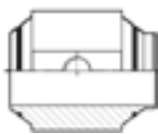

**TTB**

Please change suffixes according to material/surface required

| Order code suffixes             |                             |              |
|---------------------------------|-----------------------------|--------------|
| Material                        | Suffix surface and material | Example      |
| Steel, zinc plated, Cr(VI)-free | CF                          | TBT24-1/4CFX |
| Stainless steel                 | SS                          | TBT24-1/4SSX |



## AP – SAE flange locking plate

SAE 3000/ISO 6162-1

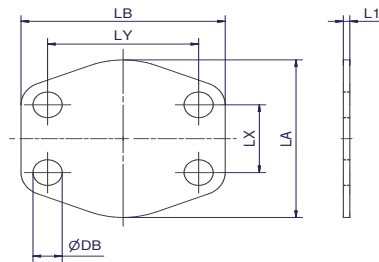

| Nom. flange size |             | L1* | LA  | LB  | LX   | LY    | DB   | Weight body<br>(Steel)<br>kg/1 piece | Order code   |
|------------------|-------------|-----|-----|-----|------|-------|------|--------------------------------------|--------------|
| SAE<br>(In)      | ISO<br>(DN) |     |     |     |      |       |      |                                      |              |
| 1/2              | 13          | 3   | 47  | 57  | 17.5 | 38.1  | 9.0  | 0.02                                 | <b>8AP1</b>  |
| 3/4              | 19          | 3   | 49  | 66  | 22.3 | 47.6  | 11.0 | 0.02                                 | <b>12AP1</b> |
| 1                | 25          | 3   | 53  | 71  | 26.2 | 52.4  | 11.0 | 0.02                                 | <b>16AP1</b> |
| 1 1/4            | 32          | 3   | 69  | 80  | 30.2 | 58.7  | 11.5 | 0.03                                 | <b>20AP1</b> |
| 1 1/2            | 38          | 3   | 77  | 95  | 35.7 | 69.9  | 13.5 | 0.03                                 | <b>24AP1</b> |
| 2                | 51          | 3   | 89  | 103 | 42.9 | 77.8  | 13.5 | 0.04                                 | <b>32AP1</b> |
| 2 1/2            | 64          | 3   | 101 | 116 | 50.8 | 89.9  | 13.5 | 0.04                                 | <b>40AP1</b> |
| 3                | 76          | 4   | 124 | 136 | 61.9 | 106.4 | 17.0 | 0.07                                 | <b>48AP1</b> |
| 3 1/2            | 89          | 4   | 136 | 152 | 69.9 | 102.7 | 17.0 | 0.07                                 | <b>56AP1</b> |
| 4                | 102         | 4   | 146 | 162 | 77.8 | 130.2 | 17.0 | 0.09                                 | <b>64AP1</b> |
| 5                | 127         | 4   | 180 | 184 | 92.1 | 152.4 | 17.0 | 0.10                                 | <b>80AP1</b> |

\*L1 x 2 with locking and rubber plate (CFSBR70)  
This flange locking plate is not used under pressure!

Please change suffixes according to material/surface required

| Order code suffixes                              |                             |             |                            |
|--|-----------------------------|-------------|----------------------------|
| Material   | Suffix surface and material | Example     | Description                |
| Steel, zinc plated, Cr(VI)-free                  | CF                          | 8AP1CF      | only locking plate         |
| Stainless steel                                  | SS                          | 8AP1SS      | only locking plate         |
| Steel (zinc plated, Cr(VI)-free), SBR 70 Shore A | CFSBR70                     | 8AP1CFSBR70 | locking incl. rubber plate |



**Bolts and nuts for flange**

SAE 3000/ISO 6162-1



**F37 Flare Flange**

| Size<br>Inch | Flange      | F37 Seal / Flat Face /<br>Bonded Seal |                       | Nut            |
|--------------|-------------|---------------------------------------|-----------------------|----------------|
|              |             | Bolts<br>Tube to Port                 | Bolts<br>Tube to Tube |                |
| 1/2          | F37-308-CFX | 4x ZYLS8X35                           | 4x ZYLS8X55           | 4x ISO4032-M8  |
| 3/4          | F37-312-CFX | 4x ZYLS10X40                          | 4x ZYLS10X65          | 4x ISO4032-M10 |
| 1            | F37-316-CFX | 4x ZYLS10X45                          | 4x ZYLS10X75          | 4x ISO4032-M10 |
| 1 1/4        | F37-320-CFX | 4x ZYLS10X40                          | 4x ZYLS10X70          | 4x ISO4032-M10 |
| 1 1/2        | F37-324-CFX | 4x ZYLS12X45                          | 4x ZYLS12X80          | 4x ISO4032-M12 |
| 2            | F37-332-CFX | 4x ZYLS12X55                          | 4x ZYLS12X100         | 4x ISO4032-M12 |
| 2 1/2        | F37-340-CFX | 4x ZYLS12X65                          | 4x ZYLS12X120         | 4x ISO4032-M12 |
| 3            | F37-348-CFX | 4x ZYLS16X80                          | 4x ZYLS16X140         | 4x ISO4032-M16 |

**Retaining Ring Flange**

| Size<br>Inch | Flange    | F37 Seal / Flat Face /<br>Bonded Seal |                       | Nut            |
|--------------|-----------|---------------------------------------|-----------------------|----------------|
|              |           | Bolts<br>Tube to Port                 | Bolts<br>Tube to Tube |                |
| 1/2          | R-308-CFX | 4x ZYLS8X35                           | 4x ZYLS8X60           | 4x ISO4032-M8  |
| 3/4          | R-312-CFX | 4x ZYLS10X40                          | 4x ZYLS10X65          | 4x ISO4032-M10 |
| 1            | R-316-CFX | 4x ZYLS10X40                          | 4x ZYLS10X70          | 4x ISO4032-M10 |
| 1 1/4        | R-320-CFX | 4x ZYLS10X40                          | 4x ZYLS10X70          | 4x ISO4032-M10 |
| 1 1/2        | R-324-CFX | 4x ZYLS12X50                          | 4x ZYLS12X80          | 4x ISO4032-M12 |
| 2            | R-332-CFX | 4x ZYLS12X55                          | 4x ZYLS12X90          | 4x ISO4032-M12 |
| 2 1/2        | R-340-CFX | 4x ZYLS12X65                          | 4x ZYLS12X120         | 4x ISO4032-M12 |
| 3            | R-348-CFX | 4x ZYLS16X80                          | 4x ZYLS16X130         | 4x ISO4032-M16 |

Bolts and nuts must be ordered separately

Latest information about nuts and bolts see [www.parker.com/tfde/servicemanuals/userguides](http://www.parker.com/tfde/servicemanuals/userguides)

Please add the suffixes according to the bolt quality

| Quality | Steel             |                  | Stainless Steel  |
|---------|-------------------|------------------|------------------|
|         | 8.8               | 10.9             |                  |
| Bolt    | ZYLS16X60X        | ZYLS16X60109X    | ZYLS16X60A4-80X  |
| Nut     | ISO-4032-M12-8VZX | ISO-4032-M12-10X | ISO-4032-M12-80X |



## KH – Ball valve

Female BSPP thread (ISO 1179-1)

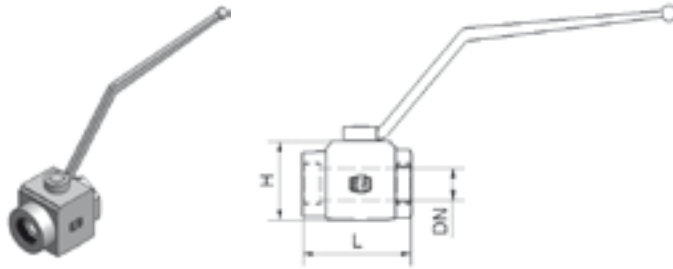

Material Steel

| Size<br>Inch | DN | L   | H   | Order code     | Weight<br>(Steel)<br>kg/1 piece | W.P.<br>bar |
|--------------|----|-----|-----|----------------|---------------------------------|-------------|
| 1 ¼          | 32 | 110 | 80  | <b>KH11/4X</b> | 3                               | 315         |
| 1 1/2        | 40 | 114 | 90  | <b>KH11/2X</b> | 4                               | 315         |
| 2            | 50 | 129 | 104 | <b>KH2X</b>    | 5                               | 400         |

Please change suffixes according to material/surface required

| Order code suffixes             |                                   |           |
|---------------------------------|-----------------------------------|-----------|
| Material                        | Suffix<br>surface<br>and material | Example   |
| Steel, zinc plated, Cr(VI)-free | CF                                | KH11/4CFX |
| Steel                           |                                   | KH11/4    |
| Stainless steel                 | 71                                | KH11/471X |

|              | Materials      |                 |
|--------------|----------------|-----------------|
| Body         | Steel          | Stainless Steel |
| Ball         | Steel          | Stainless Steel |
| Stem         | Steel          | Stainless Steel |
| Ball seats   | POM            | POM             |
| O-Ring       | NBR            | NBR             |
| Tmin / T max | -10°C / 100 °C | -30°C / 100°C   |

**KH – Ball valve drilled and tapped for SAE 3000 and SAE 6000 Flanges**

SAE 3000/ISO 6162-1

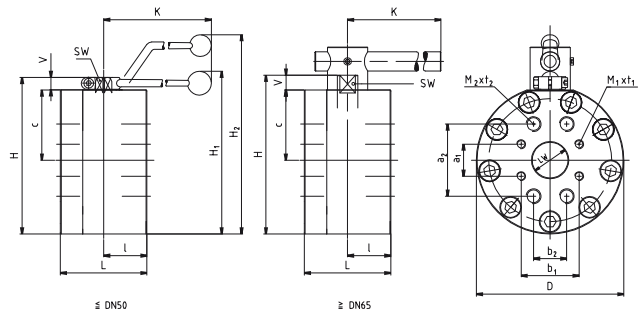

Material Steel

| Order Code       | PN (bar)  | DN | LW | L   | I  | D   | H   | c    | V  | K   | SW | a1    | b1   | M1  | t1 | H1  | H2  | Material Code | Lever | Weight kg |
|------------------|-----------|----|----|-----|----|-----|-----|------|----|-----|----|-------|------|-----|----|-----|-----|---------------|-------|-----------|
| <b>KH08-15CF</b> | 210 / 420 | 15 | 15 | 75  | 35 | 88  | 88  | 31   | 13 | 160 | 12 | 17.5  | 38.1 | M8  | 18 | -   | 132 | <b>212A</b>   | Al    | 2.96      |
| <b>KH12-20CF</b> | 210 / 420 | 20 | 20 | 80  | 35 | 98  | 100 | 36.5 | 14 | 200 | 14 | 22.2  | 47.6 | M10 | 18 | 103 | -   | <b>212A</b>   | Zn    | 4.20      |
| <b>KH16-25CF</b> | 210 / 420 | 25 | 25 | 88  | 38 | 118 | 113 | 39.5 | 14 | 200 | 14 | 52.4  | 26.2 | M10 | 20 | 116 | -   | <b>212A</b>   | Zn    | 6.00      |
| <b>KH20-32CF</b> | 210 / 420 | 32 | 32 | 100 | 50 | 145 | 158 | 68   | 17 | 320 | 17 | 30.2  | 58.7 | M12 | 20 | 167 | -   | <b>212A</b>   | Al    | 11.65     |
| <b>KH24-38CF</b> | 210 / 420 | 40 | 38 | 110 | 55 | 165 | 178 | 78   | 17 | 320 | 17 | 35.7  | 69.8 | M12 | 20 | 187 | -   | <b>212A</b>   | Al    | 17.10     |
| <b>KH32-48CF</b> | 210 / 420 | 50 | 48 | 116 | 58 | 198 | 210 | 94   | 17 | 320 | 17 | 42.9  | 77.8 | M12 | 20 | 219 | -   | <b>212A</b>   | Al    | 24.60     |
| <b>KH40-63CF</b> | 210 / 420 | 65 | 63 | 170 | 75 | 218 | 275 | 100  | 20 | 600 | 16 | 88.9  | 50.8 | M12 | 41 | -   | -   | <b>282A</b>   | St    | 44.40     |
| <b>KH48-76CF</b> | 210 / 420 | 80 | 76 | 170 | 70 | 248 | 307 | 111  | 21 | 600 | 19 | 106.4 | 61.9 | M16 | 47 | -   | -   | <b>282A</b>   | St    | 54.90     |

Steel ball valves 1/2" up to 3" with SAE 3000 and SAE 6000 boring pattern

Please change suffixes according to material/surface required

| Order code suffixes             |                             |           |
|---------------------------------|-----------------------------|-----------|
| Material                        | Suffix surface and material | Example   |
| Steel, zinc plated, Cr(VI)-free | CF                          | KH20-25CF |
| Stainless steel                 | SS                          | KH20-25SS |

|              | Material 212A |
|--------------|---------------|
| Body         | Steel         |
| Ball         | Steel         |
| Stem         | Steel         |
| Ball seats   | POM           |
| O-Ring       | NBR           |
| Tmin / T max | -10°C / 100°C |



**KH – Ball valve drilled and tapped for SAE 3000 Flanges**

SAE 3000/ISO 6162-1

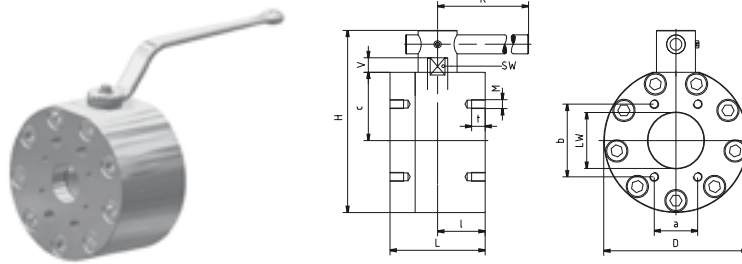

Material Steel

| Order Code        | PN (bar) | DN  | LW  | L   | I   | D   | H   | c   | V  | K   | SW | a   | b    | M   | t  | Material Code | Lever | Weight kg |
|-------------------|----------|-----|-----|-----|-----|-----|-----|-----|----|-----|----|-----|------|-----|----|---------------|-------|-----------|
| <b>KH64-100CF</b> | 210      | 100 | 100 | 170 | 85  | 258 | 326 | 122 | 27 | 900 | 24 | 130 | 78.0 | M16 | 24 | <b>282A</b>   | St(2) | 60.5      |
| <b>KH80-118CF</b> | 210      | 125 | 118 | 210 | 105 | 295 | 377 | 140 | 33 | 900 | 36 | 152 | 92.1 | M16 | 30 | <b>282A</b>   | St(2) | 95.5      |

Please change suffixes according to material/surface required

| Order code suffixes             |                             |           |
|---------------------------------|-----------------------------|-----------|
| Material                        | Suffix surface and material | Example   |
| Steel, zinc plated, Cr(VI)-free | CF                          | KH20-25CF |
| Stainless steel                 | SS                          | KH20-25SS |

|              | Material 282A   |
|--------------|-----------------|
| Body         | Steel           |
| Ball         | Steel           |
| Stem         | Stainless Steel |
| Ball seats   | POM             |
| O-Ring       | NBR             |
| Tmin / T max | -10°C / 100°C   |

**KH – Ball valve drilled and tapped for SAE 3000 Flanges**

SAE 3000/ISO 6162-1

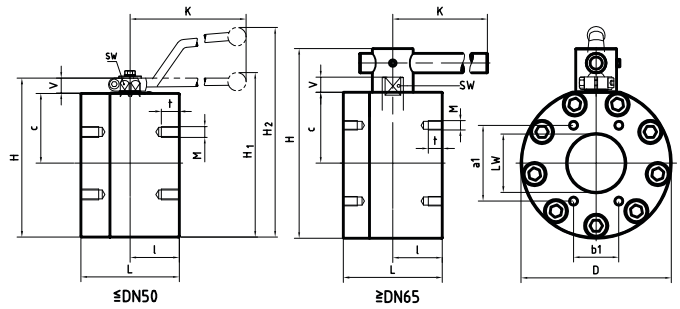

Material Stainless Steel

| Order Code | PN (bar) | DN  | LW  | L   | I   | D   | H   | c    | V  | K   | SW | a1    | b1   | M1  | t1 | H1  | H2  | Material Code | Lever | Weight kg |
|------------|----------|-----|-----|-----|-----|-----|-----|------|----|-----|----|-------|------|-----|----|-----|-----|---------------|-------|-----------|
| KH08-15SS  | 210      | 15  | 15  | 75  | 35  | 78  | 83  | 31   | 13 | 160 | 12 | 38.1  | 17.5 | M8  | 18 | -   | 127 | 442A          | Al    | 2.96      |
| KH12-20SS  | 210      | 20  | 20  | 80  | 35  | 98  | 100 | 36.5 | 14 | 200 | 14 | 47.6  | 22.2 | M10 | 18 | 103 | -   | 442A          | Zn    | 4.20      |
| KH16-25SS  | 210      | 25  | 25  | 88  | 38  | 118 | 113 | 39.5 | 14 | 200 | 14 | 52.4  | 26.2 | M10 | 20 | 116 | -   | 442A          | Zn    | 6.00      |
| KH20-32SS  | 210      | 32  | 32  | 100 | 50  | 145 | 158 | 68   | 17 | 320 | 17 | 58.7  | 30.2 | M12 | 20 | 167 | -   | 442A          | Al    | 11.65     |
| KH24-38SS  | 210      | 40  | 38  | 110 | 55  | 165 | 178 | 78   | 17 | 320 | 17 | 69.8  | 35.7 | M12 | 20 | 187 | -   | 442A          | Al    | 17.10     |
| KH32-48SS  | 210      | 50  | 48  | 116 | 58  | 198 | 210 | 94   | 17 | 320 | 17 | 77.8  | 42.9 | M12 | 20 | 219 | -   | 442A          | Al    | 24.60     |
| KH40-63SS  | 210      | 65  | 63  | 150 | 75  | 198 | 259 | 94   | 20 | 600 | 16 | 88.9  | 50.8 | M12 | 19 | -   | -   | 442A          | St    | 44.40     |
| KH48-76SS  | 210      | 80  | 76  | 140 | 70  | 210 | 277 | 100  | 26 | 600 | 19 | 106.4 | 61.9 | M16 | 24 | -   | -   | 442A          | St    | 54.90     |
| KH64-100SS | 210      | 100 | 100 | 170 | 85  | 258 | 326 | 122  | 27 | 900 | 24 | 130.2 | 77.8 | M16 | 24 | -   | -   | 442A          | St    | 60.50     |
| KH80-118SS | 210      | 125 | 118 | 210 | 105 | 295 | 377 | 140  | 33 | 900 | 36 | 152.4 | 92.1 | M16 | 30 | -   | -   | 442A          | St    | 95.50     |

Please change suffixes according to material/surface required

| Order code suffixes             |                             |           |
|---------------------------------|-----------------------------|-----------|
| Material                        | Suffix surface and material | Example   |
| Steel, zinc plated, Cr(VI)-free | CF                          | KH20-25CF |
| Stainless steel                 | SS                          | KH20-25SS |

|              | Material 442A   |
|--------------|-----------------|
| Body         | Stainless Steel |
| Ball         | Stainless Steel |
| Stem         | Stainless Steel |
| Ball seats   | POM             |
| O-Ring       | NBR             |
| Tmin / T max | -30°C / 100°C   |



**KH-R – Ball valve with SAE 3000 Flanges**

SAE 3000/ISO 6162-1

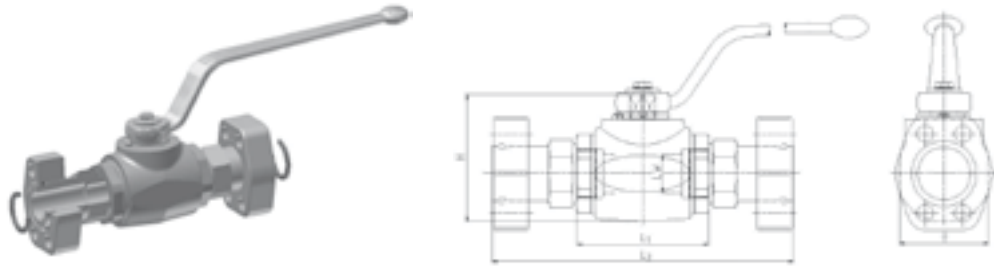

Material Steel

| Size Inch | LW | L1  | L2    | B   | H   | Complete part Order code | Valve body Order code | Weight body (Steel) kg/1 piece | W.P. bar |
|-----------|----|-----|-------|-----|-----|--------------------------|-----------------------|--------------------------------|----------|
| 3/4       | 20 | 95  | 217.0 | 49  | 75  | <b>KH-R-312-20CF</b>     | KH-R-12-20CF          | 2.5                            | 350      |
| 1         | 25 | 113 | 251.0 | 58  | 83  | <b>KH-R-316-25CF</b>     | KH-R-16-25CF          | 3.8                            | 350      |
| 1 1/4     | 32 | 111 | 271.0 | 81  | 107 | <b>KH-R-320-32CF</b>     | KH-R-20-32CF          | 6.0                            | 280      |
| 1 1/2     | 38 | 130 | 316.0 | 100 | 124 | <b>KH-R-324-38CF</b>     | KH-R-24-38CF          | 8.4                            | 280      |
| 2         | 48 | 140 | 348.0 | 118 | 138 | <b>KH-R-332-48CF</b>     | KH-R-32-48CF          | 13.9                           | 280      |

Other sizes on request

Material Stainless Steel

| Size Inch | LW | L1  | L2    | B   | H   | Complete part Order code | Valve body Order code | Weight body (Steel) kg/1 piece | W.P. bar |
|-----------|----|-----|-------|-----|-----|--------------------------|-----------------------|--------------------------------|----------|
| 3/4       | 20 | 95  | 217.0 | 49  | 75  | <b>KH-R-312-20SS</b>     | KH-R-12-20SS          | 2.5                            | 350      |
| 1         | 25 | 113 | 251.0 | 58  | 83  | <b>KH-R-316-25SS</b>     | KH-R-16-25SS          | 3.8                            | 350      |
| 1 1/4     | 32 | 111 | 271.0 | 81  | 107 | <b>KH-R-320-32SS</b>     | KH-R-20-32SS          | 8.6                            | 280      |
| 1 1/2     | 38 | 130 | 316.0 | 100 | 124 | <b>KH-R-324-38SS</b>     | KH-R-24-38SS          | 12.0                           | 280      |
| 2         | 48 | 140 | 348.0 | 118 | 138 | <b>KH-R-332-48SS</b>     | KH-R-32-48SS          | 16.1                           | 280      |

Other sizes on request

Please change suffixes according to material/surface required

| Order code suffixes             |                             |               |            |
|---------------------------------|-----------------------------|---------------|------------|
| Material                        | Suffix surface and material | Example       | Comments   |
| Steel, zinc plated, Cr(VI)-free | CF                          | KH-R-320-25CF |            |
| Stainless steel                 | SS                          | KH-R-320-25SS | on request |

|              | Materials      |                 |
|--------------|----------------|-----------------|
| Body         | Steel          | Stainless Steel |
| Ball         | Steel          | Stainless Steel |
| Stem         | Steel          | Stainless Steel |
| Ball seats   | POM            | POM             |
| O-Ring       | NBR            | NBR             |
| Tmin / T max | -20°C / 100 °C | -30°C / 100°C   |

**RHD-R – Non return valves**

SAE 3000/ISO 6162-1

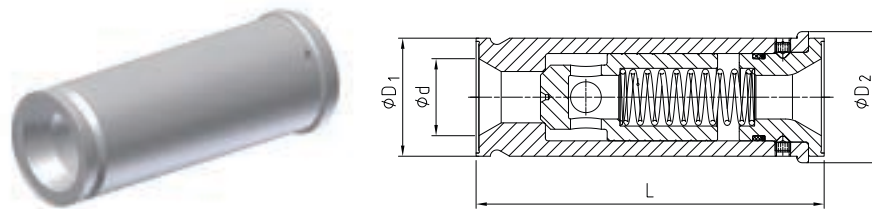

Material Steel

| Size<br>Inch | L     | D1 | D2    | d    | Complete part<br>Order code | Valve body<br>Order code | Weight body<br>(Steel)<br>kg/1 piece | W.P.<br>bar |
|--------------|-------|----|-------|------|-----------------------------|--------------------------|--------------------------------------|-------------|
| 3/4          | 96.4  | 36 | 40.2  | 20.0 | <b>RHD-R-312-0.5BCF</b>     | RHD-R-12-0.5BCF          | 0.53                                 | 210         |
| 1            | 116.6 | 39 | 44.2  | 23.0 | <b>RHD-R-316-0.5BCF</b>     | RHD-R-16-0.5BCF          | 0.78                                 |             |
| 1 1/4        | 135.6 | 46 | 51.1  | 30.0 | <b>RHD-R-320-0.5BCF</b>     | RHD-R-20-0.5BCF          | 1.26                                 |             |
| 1 1/2        | 135.6 | 56 | 60.5  | 38.8 | <b>RHD-R-324-0.5BCF</b>     | RHD-R-24-0.5BCF          | 1.61                                 |             |
| 2            | 180.1 | 66 | 70.5  | 49.0 | <b>RHD-R-332-0.5BCF</b>     | RHD-R-32-0.5BCF          | 2.54                                 |             |
| 2 1/2        | 190.0 | 80 | 84.5  | 60.0 | <b>RHD-R-340-0.5BCF</b>     | RHD-R-40-0.5BCF          | 3.89                                 |             |
| 3            | 200.0 | 97 | 103.2 | 73.0 | <b>RHD-R-348-0.5BCF</b>     | RHD-R-48-0.5BCF          | 5.90                                 |             |

Opening pressure 0.5 bar. Other pressure rates on request.

Please change suffixes according to material/surface required

| Order code suffixes                    |                                   |                  |
|--|-----------------------------------|------------------|
| Material                               | Suffix<br>surface<br>and material | Example          |
| Steel, zinc plated, Cr(VI)-free        | CF                                | RHD-R-320-0.5BCF |
| Stainless steel<br>(inner parts steel) | SS                                | RHD-R-320-0.5BSS |

|              | Materials      |
|--------------|----------------|
| Body         | Steel          |
| O-Ring       | NBR            |
| Tmin / T max | -10°C / 100 °C |

















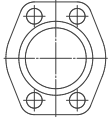
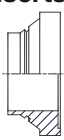
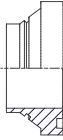
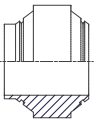
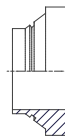

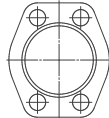

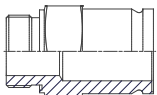
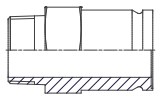

## **SAE 6000 System**

420 bar

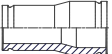
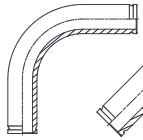
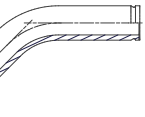
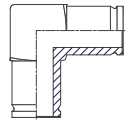
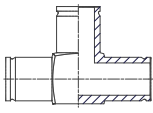
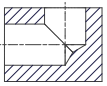
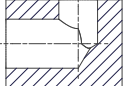
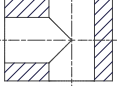
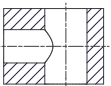
ENGINEERING YOUR SUCCESS.

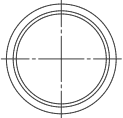
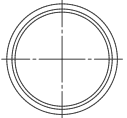
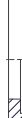
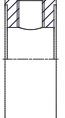
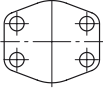

Programme overview SAE 6000/ISO 6162-2 footprint

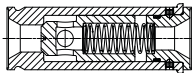
|                                 |   |  |  |   |  |  |   |  |
|---------------------------------|---|--|--|---|--|--|---|--|
| Parflange® F37 connection parts | <b>Flanges</b><br><br><b>F37 – p.118/119</b>   |  |  |   |  |  |   |  |
|                                 | <b>Inserts</b><br><br><b>TFB – p.122</b> <br><b>TFV – p.123</b> <br><b>TT – p.124</b> <br><b>TF – p.125</b>   |  |  |   |  | <b>Sleeve</b><br><br><b>SL – p.126</b>      |   |  |
| Retaining ring connection parts | <b>Flanges</b><br><br><b>R – p.120</b> <br><b>R-Ring – p.127</b> <br><b>PSC – p.121</b>  |  |  |   |  |  |   |  |
|                                 | <b>Male / Female</b><br><br><b>MTF-R – p.128</b> <br><b>MTF-N – p.129</b> <br><b>FTF-R – p.130</b>   |  |  | <b>Hose</b><br><br><b>Hose – p.131</b> |  |  | <b>Weld</b><br><br><b>WA – p.132/133</b> |  |
|                                 | <b>Tube to Tube</b><br><br><b>BF – p.134</b> <br><b>VB – p.135</b> <br><b>RF – p.136</b> <br><b>FB90 – p.137/139</b> <br><b>FB45 – p.138/140</b> <br><b>LF – p.141</b> <br><b>TF – p.142</b> |  |  |   |  |  |   |  |
| SAE connection parts            | <b>Blocks</b><br><br><b>LB – p.143</b> <br><b>LBR – p.144</b> <br><b>TB – p.145</b> <br><b>TBR – p.146</b> <br><b>BFV – p.147</b>  |  |  |   |  |  |   |  |
| Seals<br>Adapter<br>Bolts       | <b>Components</b><br><br><b>BS – p.148</b> <br><b>F37S – p.148</b> <br><b>AO – p.149</b> <br><b>TBT – p.150</b> <br><b>AP – p.151</b>  |  |  |   |  | <b>Bolts and Nuts</b><br><br><p>p.152</p> |   |  |
| Ball valves                     | <br><b>KH – p.153</b> <br><b>KH – p.154</b> <br><b>KH-R – p.155</b> <br><b>RHD-R – p.156</b>   |  |  |   |  |  |   |  |

**F37 – Flare flange | SAE 6000/ISO 6162-2 footprint**

SAE 6000/ISO 6162-2

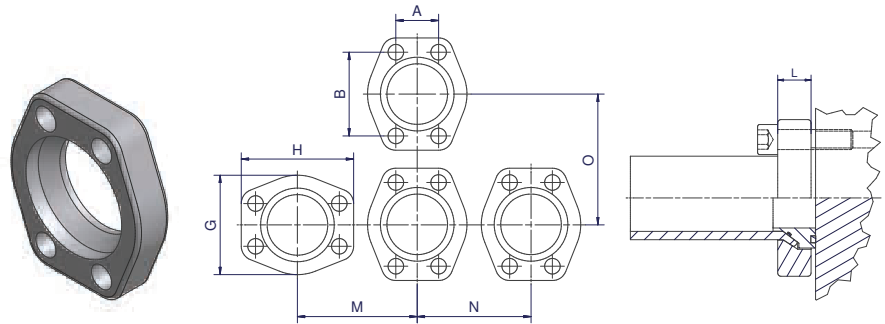

**Parflange F37 flange dimensions**

\* Jump size flanges (no adapter sleeves (SL...) necessary)

| Size Inch | Flange Order code      | A    | B    | G   | H      | M   | N   | O   | L  | Weight (Steel) kg/1 piece | W.P. bar |
|-----------|------------------------|------|------|-----|--------|-----|-----|-----|----|---------------------------|----------|
| 1/2       | <b>F37-608-CFX</b>     | 18.2 | 40.5 | 48  | 56.40  | 56  | 53  | 59  | 20 | 0.20                      | 420      |
| 3/4       | <b>F37-612-CFX</b>     | 23.8 | 50.8 | 60  | 71.35  | 70  | 66  | 75  | 24 | 0.35                      | 420      |
| 3/4       | <b>F37-612/25-CFX*</b> | 23.8 | 50.8 | 60  | 71.35  | 70  | 66  | 75  | 24 | 0.45                      | 420      |
| 1         | <b>F37-616-CFX</b>     | 27.8 | 57.2 | 70  | 81.00  | 80  | 75  | 84  | 24 | 0.53                      | 420      |
| 1         | <b>F37-616/25-CFX*</b> | 27.8 | 57.2 | 70  | 81.00  | 80  | 75  | 84  | 24 | 0.64                      | 420      |
| 1         | <b>F37-616/30-CFX*</b> | 27.8 | 57.2 | 70  | 81.00  | 80  | 75  | 84  | 24 | 0.53                      | 420      |
| 1 1/4     | <b>F37-620-CFX</b>     | 31.8 | 66.6 | 78  | 95.50  | 90  | 83  | 99  | 30 | 0.92                      | 420      |
| 1 1/4     | <b>F37-620/38-CFX*</b> | 31.8 | 66.6 | 78  | 95.50  | 90  | 83  | 99  | 30 | 0.92                      | 420      |
| 1 1/2     | <b>F37-624-CFX</b>     | 36.5 | 79.3 | 95  | 112.00 | 108 | 101 | 116 | 35 | 1.54                      | 420      |
| 1 1/2     | <b>F37-624/42-CFX*</b> | 36.5 | 79.3 | 95  | 112.00 | 108 | 101 | 116 | 35 | 1.54                      | 420      |
| 2         | <b>F37-632-CFX</b>     | 44.5 | 96.8 | 114 | 133.50 | 128 | 120 | 137 | 40 | 2.44                      | 420      |
| 2         | <b>F37-632/50-CFX*</b> | 44.5 | 96.8 | 114 | 133.50 | 128 | 120 | 137 | 40 | 2.76                      | 420      |

**Parflange F37 flange dimensions**

\* Jump size flanges (no adapter sleeves (SL...) necessary)

| Size Inch | Flange Order code       | A    | B    | G   | H      | M   | N   | O   | L  | Thread | Weight (Steel) kg/1 piece | W.P. bar |
|-----------|-------------------------|------|------|-----|--------|-----|-----|-----|----|--------|---------------------------|----------|
| 3/4       | <b>F37-612T-CFX</b>     | 23.8 | 50.8 | 60  | 71.35  | 70  | 66  | 75  | 24 | M10    | 0.35                      | 420      |
| 1         | <b>F37-616T-CFX</b>     | 27.8 | 57.2 | 70  | 81.00  | 80  | 75  | 84  | 24 | M10    | 0.53                      | 420      |
| 1         | <b>F37-616/25T-CFX*</b> | 27.8 | 57.2 | 70  | 81.00  | 80  | 75  | 84  | 24 | M12    | 0.64                      | 420      |
| 1 1/4     | <b>F37-620T-CFX</b>     | 31.8 | 66.6 | 78  | 95.50  | 90  | 83  | 99  | 30 | M10    | 0.92                      | 420      |
| 1 1/4     | <b>F37-620/38T-CFX*</b> | 31.8 | 66.6 | 78  | 95.50  | 90  | 83  | 99  | 30 | M12    | 0.92                      | 420      |
| 1 1/2     | <b>F37-624T-CFX</b>     | 36.5 | 79.3 | 95  | 112.00 | 108 | 101 | 116 | 35 | M12    | 1.54                      | 420      |
| 2         | <b>F37-632T-CFX</b>     | 44.5 | 96.8 | 114 | 133.50 | 128 | 120 | 137 | 40 | M12    | 2.44                      | 420      |

Please change suffixes according to material/surface required

| Order code suffixes             |                             |              |            |
|---------------------------------|-----------------------------|--------------|------------|
| Material                        | Suffix surface and material | Example      | Comments   |
| Steel, zinc plated, Cr(VI)-free | CF                          | F37-620-CFX  |            |
| Stainless steel                 | SS                          | F37-620-SSX  |            |
| Galvanized hot dip zinc         | TZN                         | F37-620-TZNX | on request |



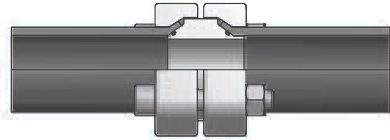

Part combination flaring SAE 6000

| Flange Pressure (bar) | Size Inch | Pipe Size | Flange SAE 6000 ISO 6162-2 | Insert*         | F37 Seal | Sleeve           | F37 Seal / Flat Face / Bonded Seal |                    | Nuts            |
|-----------------------|-----------|-----------|----------------------------|-----------------|----------|------------------|------------------------------------|--------------------|-----------------|
|                       |           |           |                            |                 |          |                  | Bolts Tube to Port                 | Bolts Tube to Tube |                 |
| 420                   | 1/2       | 16X2.0    | F37-608-CFX                | IN08-16X2.0T... | F37S08X  | SL08-25-16-CFX   | 4 x ZYLS8X35                       | 4 x ZYLS8X65       | 4 x ISO4032-M8  |
|                       | 1/2       | 18X2.0    | F37-608-CFX                | IN08-18X2.0T... | F37S08X  | SL08-25-18-CFX   | 4 x ZYLS8X35                       | 4 x ZYLS8X65       | 4 x ISO4032-M8  |
|                       | 1/2       | 20X2.0    | F37-608-CFX                | IN08-20X2.0T... | F37S08X  | SL08-25-20-CFX   | 4 x ZYLS8X35                       | 4 x ZYLS8X65       | 4 x ISO4032-M8  |
|                       | 1/2       | 20X2.5    | F37-608-CFX                | IN08-20X2.5T... | F37S08X  | SL08-25-20-CFX   | 4 x ZYLS8X35                       | 4 x ZYLS8X65       | 4 x ISO4032-M8  |
|                       | 1/2       | 25X2.5    | F37-608-CFX                | IN08-25X2.5T... | F37S08X  |                  | 4 x ZYLS8X35                       | 4 x ZYLS8X65       | 4 x ISO4032-M8  |
|                       | 1/2       | 25X3.0    | F37-608-CFX                | IN08-25X3.0T... | F37S08X  |                  | 4 x ZYLS8X35                       | 4 x ZYLS8X65       | 4 x ISO4032-M8  |
|                       | 3/4       | 20X2.0    | F37-612-CFX                | IN12-20X2.0T... | F37S12X  | SL12-30-20-CFX   | 4 x ZYLS10X45                      | 4 x ZYLS10X75      | 4 x ISO4032-M10 |
|                       | 3/4       | 20X2.5    | F37-612-CFX                | IN12-20X2.5T... | F37S12X  | SL12-30-20-CFX   | 4 x ZYLS10X45                      | 4 x ZYLS10X75      | 4 x ISO4032-M10 |
|                       | 3/4       | 25X2.5    | F37-612-CFX                | IN12-25X2.5T... | F37S12X  | SL12-30-25-CFX** | 4 x ZYLS10X45                      | 4 x ZYLS10X75      | 4 x ISO4032-M10 |
|                       | 3/4       | 25X3.0    | F37-612-CFX                | IN12-25X3.0T... | F37S12X  | SL12-30-25-CFX** | 4 x ZYLS10X45                      | 4 x ZYLS10X75      | 4 x ISO4032-M10 |
|                       | 3/4       | 30X3.0    | F37-612-CFX                | IN12-30X3.0T... | F37S12X  |                  | 4 x ZYLS10X45                      | 4 x ZYLS10X75      | 4 x ISO4032-M10 |
|                       | 3/4       | 30X4.0    | F37-612-CFX                | IN12-30X4.0T... | F37S12X  |                  | 4 x ZYLS10X45                      | 4 x ZYLS10X75      | 4 x ISO4032-M10 |
|                       | 1         | 25X2.5    | F37-616-CFX                | IN16-25X2.5T... | F37S16X  | SL16-38-25-CFX** | 4 x ZYLS12X45                      | 4 x ZYLS12X75      | 4 x ISO4032-M12 |
|                       | 1         | 25X3.0    | F37-616-CFX                | IN16-25X3.0T... | F37S16X  | SL16-38-25-CFX** | 4 x ZYLS12X45                      | 4 x ZYLS12X75      | 4 x ISO4032-M12 |
|                       | 1         | 30X3.0    | F37-616-CFX                | IN16-30X3.0T... | F37S16X  | SL16-38-30-CFX** | 4 x ZYLS12X45                      | 4 x ZYLS12X75      | 4 x ISO4032-M12 |
|                       | 1         | 30X4.0    | F37-616-CFX                | IN16-30X4.0T... | F37S16X  | SL16-38-30-CFX** | 4 x ZYLS12X45                      | 4 x ZYLS12X75      | 4 x ISO4032-M12 |
|                       | 1         | 38X2.5    | F37-616-CFX                | IN16-38X2.5T... | F37S16X  |                  | 4 x ZYLS12X45                      | 4 x ZYLS12X75      | 4 x ISO4032-M12 |
|                       | 1         | 38X3.0    | F37-616-CFX                | IN16-38X3.0T... | F37S16X  |                  | 4 x ZYLS12X45                      | 4 x ZYLS12X75      | 4 x ISO4032-M12 |
|                       | 1         | 38X4.0    | F37-616-CFX                | IN16-38X4.0T... | F37S16X  |                  | 4 x ZYLS12X45                      | 4 x ZYLS12X75      | 4 x ISO4032-M12 |
|                       | 1         | 38X5.0    | F37-616-CFX                | IN16-38X5.0T... | F37S16X  |                  | 4 x ZYLS12X45                      | 4 x ZYLS12X75      | 4 x ISO4032-M12 |
|                       | 1 1/4     | 30X3.0    | F37-620-CFX                | IN20-30X3.0T... | F37S20X  | SL20-42-30-CFX   | 4 x ZYLS14X55                      | 4 x ZYLS14 x90     | 4 x ISO4032-M14 |
|                       | 1 1/4     | 30X4.0    | F37-620-CFX                | IN20-30X4.0T... | F37S20X  | SL20-42-30-CFX   | 4 x ZYLS14X55                      | 4 x ZYLS14 x90     | 4 x ISO4032-M14 |
|                       | 1 1/4     | 38X3.0    | F37-620-CFX                | IN20-38X3.0T... | F37S20X  | SL20-42-38-CFX** | 4 x ZYLS14X55                      | 4 x ZYLS14 x90     | 4 x ISO4032-M14 |
|                       | 1 1/4     | 38X4.0    | F37-620-CFX                | IN20-38X4.0T... | F37S20X  | SL20-42-38-CFX** | 4 x ZYLS14X55                      | 4 x ZYLS14 x90     | 4 x ISO4032-M14 |
|                       | 1 1/4     | 38X5.0    | F37-620-CFX                | IN20-38X5.0T... | F37S20X  | SL20-42-38-CFX** | 4 x ZYLS14X55                      | 4 x ZYLS14 x90     | 4 x ISO4032-M14 |
|                       | 1 1/4     | 42X3.0    | F37-620-CFX                | IN20-42X3.0T... | F37S20X  |                  | 4 x ZYLS14X55                      | 4 x ZYLS14 x90     | 4 x ISO4032-M14 |
|                       | 1 1/4     | 42X4.0    | F37-620-CFX                | IN20-42X4.0T... | F37S20X  |                  | 4 x ZYLS14X55                      | 4 x ZYLS14 x90     | 4 x ISO4032-M14 |
|                       | 1 1/2     | 38X3.0    | F37-624-CFX                | IN24-38X3.0T... | F37S24X  | SL24-50-38-CFX   | 4 x ZYLS16X60                      | 4 x ZYLS16X100     | 4 x ISO4032-M16 |
|                       | 1 1/2     | 38X4.0    | F37-624-CFX                | IN24-38X4.0T... | F37S24X  | SL24-50-38-CFX   | 4 x ZYLS16X60                      | 4 x ZYLS16X100     | 4 x ISO4032-M16 |
|                       | 1 1/2     | 38X5.0    | F37-624-CFX                | IN24-38X5.0T... | F37S24X  | SL24-50-38-CFX   | 4 x ZYLS16X60                      | 4 x ZYLS16X100     | 4 x ISO4032-M16 |
|                       | 1 1/2     | 42X3.0    | F37-624-CFX                | IN24-42X3.0T... | F37S24X  | SL24-50-42-CFX** | 4 x ZYLS16X60                      | 4 x ZYLS16X100     | 4 x ISO4032-M16 |
|                       | 1 1/2     | 42X4.0    | F37-624-CFX                | IN24-42X4.0T... | F37S24X  | SL24-50-42-CFX** | 4 x ZYLS16X60                      | 4 x ZYLS16X100     | 4 x ISO4032-M16 |
|                       | 1 1/2     | 50X3.0    | F37-624-CFX                | IN24-50X3.0T... | F37S24X  |                  | 4 x ZYLS16X60                      | 4 x ZYLS16X100     | 4 x ISO4032-M16 |
|                       | 1 1/2     | 50X5.0    | F37-624-CFX                | IN24-50X5.0T... | F37S24X  |                  | 4 x ZYLS16X60                      | 4 x ZYLS16X100     | 4 x ISO4032-M16 |
|                       | 1 1/2     | 50X6.0    | F37-624-CFX                | IN24-50X6.0T... | F37S24X  |                  | 4 x ZYLS16X60                      | 4 x ZYLS16X100     | 4 x ISO4032-M16 |
|                       | 2         | 50X3.0    | F37-632-CFX                | IN32-50X3.0T... | F37S32X  | SL32-60-50-CFX** | 4 x ZYLS20X70                      | 4 x ZYLS20X120     | 4 x ISO4032-M20 |
|                       | 2         | 50X5.0    | F37-632-CFX                | IN32-50X5.0T... | F37S32X  | SL32-60-50-CFX** | 4 x ZYLS20X70                      | 4 x ZYLS20X120     | 4 x ISO4032-M20 |
|                       | 2         | 50X6.0    | F37-632-CFX                | IN32-50X6.0T... | F37S32X  | SL32-60-50-CFX** | 4 x ZYLS20X70                      | 4 x ZYLS20X120     | 4 x ISO4032-M20 |
|                       | 2         | 60X3.0    | F37-632-CFX                | IN32-60X3.0T... | F37S32X  |                  | 4 x ZYLS20X70                      | 4 x ZYLS20X120     | 4 x ISO4032-M20 |
|                       | 2         | 60X5.0    | F37-632-CFX                | IN32-60X5.0T... | F37S32X  |                  | 4 x ZYLS20X70                      | 4 x ZYLS20X120     | 4 x ISO4032-M20 |
|                       | 2         | 60X6.0    | F37-632-CFX                | IN32-60X6.0T... | F37S32X  |                  | 4 x ZYLS20X70                      | 4 x ZYLS20X120     | 4 x ISO4032-M20 |

Select the complete version:

- \* ...FBCF Bonded Seal version
- ...FVCF F37 Seal version
- ...TCF Tube to Tube version
- ...FCF Flat Face version

\*\*Jump size flanges available alternatively to adapter sleeve, see page 74

Pressure rates related to flanges.

Other sizes like schedule on request

Bolts and nuts are not included in a complete part.

Bolt and nuts for flanges see page 144

**R – Retaining ring flange | SAE 6000/ISO 6162-2 footprint**

SAE 6000/ISO 6162-2

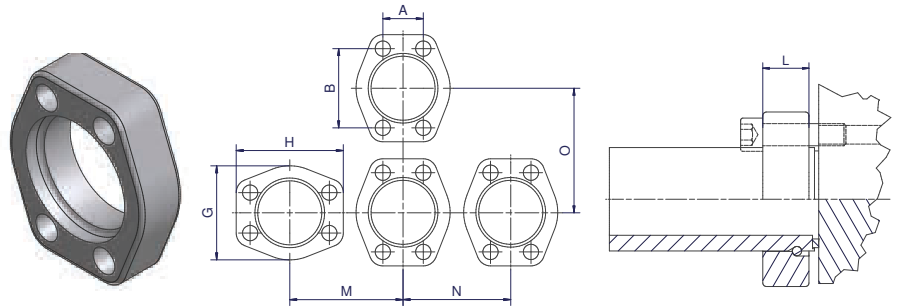

**Retaining ring flange dimensions**

| Size Inch | Flange Order code | A    | B    | G   | H     | M   | N   | O   | L  | Weight (Steel) kg/1 piece | W.P. bar |
|-----------|-------------------|------|------|-----|-------|-----|-----|-----|----|---------------------------|----------|
| 1/2       | <b>R-608-CFX</b>  | 18.2 | 40.5 | 48  | 56.4  | 56  | 53  | 59  | 20 | 0.22                      | 420      |
| 3/4       | <b>R-612-CFX</b>  | 23.8 | 50.8 | 60  | 71.35 | 70  | 66  | 75  | 24 | 0.39                      | 420      |
| 1         | <b>R-616-CFX</b>  | 27.8 | 57.2 | 70  | 81    | 80  | 75  | 84  | 24 | 0.55                      | 420      |
| 1 1/4     | <b>R-620-CFX</b>  | 31.8 | 66.6 | 78  | 95.5  | 90  | 83  | 99  | 30 | 0.89                      | 420      |
| 1 1/2     | <b>R-624-CFX</b>  | 36.5 | 79.3 | 95  | 112   | 108 | 101 | 116 | 35 | 1.46                      | 420      |
| 2         | <b>R-632-CFX</b>  | 44.5 | 96.8 | 114 | 133.5 | 128 | 120 | 137 | 40 | 2.35                      | 420      |

Please change suffixes according to material/surface required

| Order code suffixes             |                             |            |            |
|---------------------------------|-----------------------------|------------|------------|
| Material                        | Suffix surface and material | Example    | Comments   |
| Steel, zinc plated, Cr(VI)-free | CF                          | R-620-CFX  |            |
| Stainless steel                 | SS                          | R-620-SSX  |            |
| Galvanized hot dip zinc         | TZN                         | R-620-TZNX | on request |

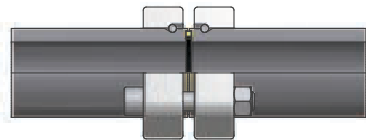

**Part combination Bonded seal SAE 6000 connection**

| Flange pressure (bar) | Size Inch | Pipe Size | Flange    | Retaining Ring | Bonded Seal | Bolts Tube to Port | Bolts Tube to Tube | Nut             |
|-----------------------|-----------|-----------|-----------|----------------|-------------|--------------------|--------------------|-----------------|
| <b>420</b>            | 1/2       | 26X6.0    | R-608-CFX | R08X           | BS08SNX     | 4 x ZYLS8X35       | 4 x ZYLS8X60       | 4 x ISO4032-M8  |
|                       | 3/4       | 36X8.0    | R-612-CFX | R12X           | BS12SNX     | 4 x ZYLS10X45      | 4 x ZYLS10X80      | 4 x ISO4032-M10 |
|                       | 1         | 39X7.5    | R-616-CFX | R16X           | BS16SNX     | 4 x ZYLS12X45      | 4 x ZYLS12X80      | 4 x ISO4032-M12 |
|                       | 1 1/4     | 46X8.0    | R-620-CFX | R20X           | BS20SNX     | 4 x ZYLS14X50      | 4 x ZYLS14X90      | 4 x ISO4032-M14 |
|                       | 1 1/2     | 56X8.5    | R-624-CFX | R24X           | BS24SNX     | 4 x ZYLS16X60      | 4 x ZYLS16X110     | 4 x ISO4032-M16 |
|                       | 2         | 66X8.5    | R-632-CFX | R32X           | BS32SNX     | 4 x ZYLS20X70      | 4 x ZYLS20X110     | 4 x ISO4032-M20 |



**PSC – Pipe seal carrier | SAE 6000/ISO 6162-2 footprint**

SAE 6000/ISO 6162-2

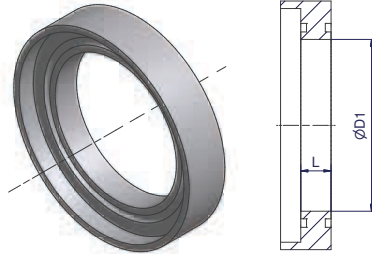

| Size Inch | Pipe size | L    | D1 | Seal carrier    | Flange pressure (bar) |
|-----------|-----------|------|----|-----------------|-----------------------|
| 2         | 66X8.5    | 10,0 | 49 | PSC32-66X8.5VCF | 420                   |
| 2 1/2     | 80X10     | 15.0 | 60 | PSC40-80X10VCF  |                       |
| 3         | 97X12     | 15.0 | 73 | PSC48-97X12VCF  |                       |

Other sizes on request  
 Steel PSC incl. seals  
 Stainless steel PSC without seals

Please change suffixes according to material/surface required

| Order code suffixes             |                             |                 |
|---------------------------------|-----------------------------|-----------------|
| Material                        | Suffix surface and material | Example         |
| Steel, zinc plated, Cr(VI)-free | CF                          | PSC40-80X10VCF  |
| Stainless steel                 | SS                          | PSC40-80X10VSSX |

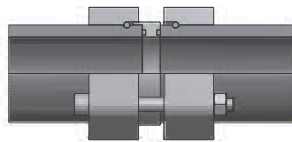

Part combination Pipe seal carrier SAE 6000 connection

| Flange pressure (bar) | Size Inch | Pipe Size | Flange    | Retaining Ring | Seal Carrier    | SO-Ring          | Bolts Tube to Port | Bolts Tube to Tube | Nut         |
|-----------------------|-----------|-----------|-----------|----------------|-----------------|------------------|--------------------|--------------------|-------------|
| <b>420</b>            | 2         | 66X8.5    | R-632-CFX | R32X           | PSC32-66X8.5VCF | 2 x OR55.25X2.62 | 4 x ZYLS20X80      | 4 x ZYLS20X120     | ISO4032-M20 |
|                       | 2 1/2     | 80X10     | R-640-CFX | R40X           | PSC40-80X10VCF  | 2 x OR66.27X3.53 | 4 x ZYLS24X100     | 4 x ZYLS24X150     | ISO4032-M24 |
|                       | 3         | 97X12     | R-648-CFX | R48X           | PSC48-97X12VCF  | 2 x OR78.97X3.53 | 4 x ZYLS30X110     | 4 x ZYLS30X160     | ISO4032-M30 |

Other sizes on request



## TFB – Flare flange connection

Tube to port connection, bonded seal

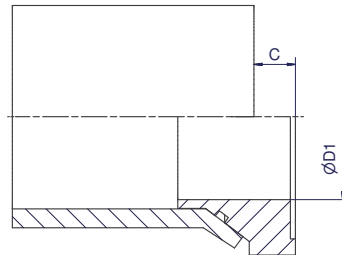
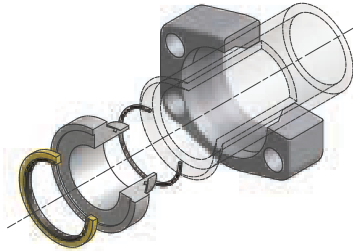

| Size  |        | Flange* incl. Insert +<br>Bonded Seal + O-Ring<br>Order code | D1   | C    | Insert incl.<br>Bonded Seal + O-Ring<br>Order code | Bonded Seal<br>Order code | O-Ring<br>Order code | Weight<br>(Steel)<br>kg/1 piece |
|-------|--------|--|------|------|--|---------------------------|----------------------|---------------------------------|
| Inch  | Tube   |  |      |      |  |                           |                      |                                 |
| 1/2   | 16X2.0 | F37-608-16X2.0TFBCF  | 9.5  | 8.0  | IN08-16X2.0TFBCF                                   | BS08SNX                   | OR12X1.0X            | 0.24                            |
| 1/2   | 18X2.0 | F37-608-18X2.0TFBCF  | 11.5 | 8.0  | IN08-18X2.0TFBCF                                   | BS08SNX                   | OR14X1.1X            | 0.24                            |
| 1/2   | 20X2.0 | F37-608-20X2.0TFBCF  | 13.5 | 8.0  | IN08-20X2.0TFBCF                                   | BS08SNX                   | OR16X1.0X            | 0.24                            |
| 1/2   | 20X2.5 | F37-608-20x2.5TFBCF  | 13.5 | 8.0  | IN08-20X2.5TFBCF                                   | BS08SNX                   | OR16X1.0X            | 0.24                            |
| 1/2   | 25X2.5 | F37-608-25X2.5TFBCF  | 13.5 | 10.0 | IN08-25X2.5TFBCF                                   | BS08SNX                   | OR20X1.0X            | 0.25                            |
| 1/2   | 25X3.0 | F37-608-25X3.0TFBCF  | 13.0 | 8.0  | IN08-25X3.0TFBCF                                   | BS08SNX                   | OR20X1.0X            | 0.24                            |
| 3/4   | 20X2.0 | F37-612-20X2.0TFBCF  | 13.5 | 8.0  | IN12-20X2.0TFBCF                                   | BS12SNX                   | OR16X1.0X            | 0.41                            |
| 3/4   | 20X2.5 | F37-612-20X2.5TFBCF  | 12.5 | 8.0  | IN12-20X2.5TFBCF                                   | BS12SNX                   | OR16X1.0X            | 0.41                            |
| 3/4   | 25X2.5 | F37-612-25X2.5TFBCF  | 17.5 | 10.0 | IN12-25X2.5TFBCF                                   | BS12SNX                   | OR20X1.0X            | 0.41                            |
| 3/4   | 25X3.0 | F37-612-25X3.0TFBCF  | 16.5 | 8.0  | IN12-25X3.0TFBCF                                   | BS12SNX                   | OR20X1.0X            | 0.42                            |
| 3/4   | 30X3.0 | F37-612-30X3.0TFBCF  | 19.0 | 8.5  | IN12-30X3.0TFBCF                                   | BS12SNX                   | OR25X1.0X            | 0.42                            |
| 3/4   | 30X4.0 | F37-612-30X4.0TFBCF  | 19.5 | 8.5  | IN12-30X4.0TFBCF                                   | BS12SNX                   | OR22X1.0X            | 0.42                            |
| 1     | 25X2.5 | F37-616-25X2.5TFBCF  | 17.5 | 10.0 | IN16-25X2.5TFBCF                                   | BS16SNX                   | OR20X1.0X            | 0.62                            |
| 1     | 25X3.0 | F37-616-25X3.0TFBCF  | 16.5 | 8.0  | IN16-25X3.0TFBCF                                   | BS16SNX                   | OR20X1.0X            | 0.62                            |
| 1     | 30X3.0 | F37-616-30X3.0TFBCF  | 21.5 | 8.5  | IN16-30X3.0TFBCF                                   | BS16SNX                   | OR25X1.0X            | 0.62                            |
| 1     | 30X4.0 | F37-616-30X4.0TFBCF  | 19.5 | 8.5  | IN16-30X4.0TFBCF                                   | BS16SNX                   | OR22X1.0X            | 0.62                            |
| 1     | 38X2.5 | F37-616-38X2.5TFBCF  | 25.0 | 9.5  | IN16-38X2.5TFBCF                                   | BS16SNX                   | OR34X1.0X            | 0.64                            |
| 1     | 38X3.0 | F37-616-38X3.0TFBCF  | 25.0 | 9.0  | IN16-38X3.0TFBCF                                   | BS16SNX                   | OR34X1.0X            | 0.63                            |
| 1     | 38X4.0 | F37-616-38X4.0TFBCF  | 25.0 | 10.0 | IN16-38X4.0TFBCF                                   | BS16SNX                   | OR30X1.0X            | 0.63                            |
| 1     | 38X5.0 | F37-616-38X5.0TFBCF  | 25.0 | 8.0  | IN16-38X5.0TFBCF                                   | BS16SNX                   | OR28X1.0X            | 0.62                            |
| 1 1/4 | 30X3.0 | F37-620-30X3.0TFBCF  | 21.5 | 8.5  | IN20-30X3.0TFBCF                                   | BS20SNX                   | OR25X1.0X            | 1.03                            |
| 1 1/4 | 30X4.0 | F37-620-30X4.0TFBCF  | 19.5 | 8.5  | IN20-30X4.0TFBCF                                   | BS20SNX                   | OR22X1.0X            | 1.04                            |
| 1 1/4 | 38X3.0 | F37-620-38X3.0TFBCF  | 29.5 | 9.0  | IN20-38X3.0TFBCF                                   | BS20SNX                   | OR34X1.0X            | 1.02                            |
| 1 1/4 | 38X4.0 | F37-620-38X4.0TFBCF  | 27.0 | 10.0 | IN20-38X4.0TFBCF                                   | BS20SNX                   | OR30X1.0X            | 1.03                            |
| 1 1/4 | 38X5.0 | F37-620-38X5.0TFBCF  | 25.5 | 8.0  | IN20-38X5.0TFBCF                                   | BS20SNX                   | OR28X1.0X            | 1.02                            |
| 1 1/4 | 42X3.0 | F37-620-42X3.0TFBCF  | 31.5 | 10.0 | IN20-42X3.0TFBCF                                   | BS20SNX                   | OR37.82X1.78X        | 1.03                            |
| 1 1/4 | 42X4.0 | F37-620-42X4.0TFBCF  | 31.5 | 10.0 | IN20-42X4.0TFBCF                                   | BS20SNX                   | OR34X1.0X            | 1.02                            |
| 1 1/2 | 38X3.0 | F37-624-38X3.0TFBCF  | 27.5 | 9.0  | IN24-38X3.0TFBCF                                   | BS24SNX                   | OR34X1.0X            | 1.11                            |
| 1 1/2 | 38X4.0 | F37-624-38X4.0TFBCF  | 27.5 | 10.0 | IN24-38X4.0TFBCF                                   | BS24SNX                   | OR30X1.0X            | 1.73                            |
| 1 1/2 | 38X5.0 | F37-624-38X5.0TFBCF  | 25.0 | 8.0  | IN24-38X5.0TFBCF                                   | BS24SNX                   | OR28X1.0X            | 1.73                            |
| 1 1/2 | 42X3.0 | F37-624-42X3.0TFBCF  | 35.0 | 10.0 | IN24-42X3.0TFBCF                                   | BS24SNX                   | OR37.82X1.78X        | 1.74                            |
| 1 1/2 | 42X4.0 | F37-624-42X4.0TFBCF  | 31.5 | 10.0 | IN24-42X4.0TFBCF                                   | BS24SNX                   | OR34X1.0X            | 1.73                            |
| 1 1/2 | 50X3.0 | F37-624-50X3.0TFBCF  | 36.0 | 11.0 | IN24-50X3.0TFBCF                                   | BS24SNX                   | OR44.17X1.78X        | 1.73                            |
| 1 1/2 | 50X5.0 | F37-624-50X5.0TFBCF  | 36.0 | 10.0 | IN24-50X5.0TFBCF                                   | BS24SNX                   | OR41X1.78X           | 1.73                            |
| 1 1/2 | 50X6.0 | F37-624-50X6.0TFBCF  | 35.0 | 10.0 | IN24-50X6.0TFBCF                                   | BS24SNX                   | OR41X1.78X           | 1.73                            |
| 2     | 50X3.0 | F37-632-50X3.0TFBCF  | 41.5 | 11.0 | IN32-50X3.0TFBCF                                   | BS32SNX                   | OR44.17X1.78X        | 2.66                            |
| 2     | 50X5.0 | F37-632-50X5.0TFBCF  | 37.5 | 10.0 | IN32-50X5.0TFBCF                                   | BS32SNX                   | OR41X1.78X           | 2.68                            |
| 2     | 50X6.0 | F37-632-50X6.0TFBCF  | 35.0 | 10.0 | IN32-50X6.0TFBCF                                   | BS32SNX                   | OR41X1.78X           | 2.71                            |
| 2     | 60X3.0 | F37-632-60X3.0TFBCF  | 46.0 | 12.0 | IN32-60X3.0TFBCF                                   | BS32SNX                   | OR53.7X1.78X         | 2.71                            |
| 2     | 60X5.0 | F37-632-60X5.0TFBCF  | 46.0 | 11.0 | IN32-60X5.0TFBCF                                   | BS32SNX                   | OR50.52X1.78X        | 2.68                            |
| 2     | 60X6.0 | F37-632-60X6.0TFBCF  | 45.5 | 11.0 | IN32-60X6.0TFBCF                                   | BS32SNX                   | OR47.37X1.78X        | 2.67                            |

Other sizes on request. \*Incl. adapter sleeve or jump size flange if necessary.

Please change suffixes according to material/surface required

| Order code suffixes             |                             |                     |
|---------------------------------|-----------------------------|---------------------|
| Material                        | Suffix surface and material | Example             |
| Steel, zinc plated, Cr(VI)-free | CF                          | F37-624-50X5.0TFBCF |
| Stainless steel                 | SS                          | F37-624-50X5.0TFBSS |



**TFV – Flare flange connection**

Tube to port connection, F37 seal

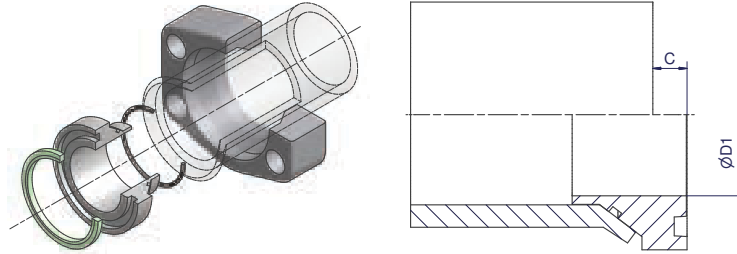

| Size  |        | Flange* incl. Insert +<br>F37 Seal + O-Ring<br>Order code | D1   | C    | Insert incl.<br>F37 Seal + O-Ring<br>Order code | F37 Seal<br>Order code | O-Ring<br>Order code | Weight<br>(Steel)<br>kg/1 piece |
|-------|--------|---|------|------|---|------------------------|----------------------|---------------------------------|
| Inch  | Tube   |   |      |      |   |                        |                      |                                 |
| 1/2   | 16X2.0 | F37-608-16X2.0TFVCF                                       | 9.5  | 8.0  | IN08-16X2.0TFVCF                                | F37S08X                | OR12X1.0X            | 0.24                            |
| 1/2   | 18X2.0 | F37-608-18X2.0TFVCF                                       | 9.5  | 8.0  | IN08-18X2.0TFVCF                                | F37S08X                | OR14X1.1X            | 0.24                            |
| 1/2   | 20X2.0 | F37-608-20X2.0TFVCF                                       | 11.5 | 8.0  | IN08-20X2.0TFVCF                                | F37S08X                | OR16X1.0X            | 0.24                            |
| 1/2   | 20X2.5 | F37-608-20X2.5TFVCF                                       | 13.5 | 8.0  | IN08-20X2.5TFVCF                                | F37S08X                | OR16X1.0X            | 0.24                            |
| 1/2   | 25X2.5 | F37-608-25X2.5TFVCF                                       | 13.5 | 10.0 | IN08-25X2.5TFVCF                                | F37S08X                | OR20X1.0X            | 0.25                            |
| 1/2   | 25X3.0 | F37-608-25X3.0TFVCF                                       | 13.5 | 8.0  | IN08-25X3.0TFVCF                                | F37S08X                | OR20X1.0X            | 0.24                            |
| 3/4   | 20X2.0 | F37-612-20X2.0TFVCF                                       | 13.0 | 8.0  | IN12-20X2.0TFVCF                                | F37S12X                | OR16X1.0X            | 0.41                            |
| 3/4   | 20X2.5 | F37-612-20X2.5TFVCF                                       | 13.5 | 8.0  | IN12-20X2.5TFVCF                                | F37S12X                | OR16X1.0X            | 0.41                            |
| 3/4   | 25X2.5 | F37-612-25X2.5TFVCF                                       | 12.5 | 10.0 | IN12-25X2.5TFVCF                                | F37S12X                | OR20X1.0X            | 0.41                            |
| 3/4   | 25X3.0 | F37-612-25X3.0TFVCF                                       | 17.5 | 8.0  | IN12-25X3.0TFVCF                                | F37S12X                | OR20X1.0X            | 0.42                            |
| 3/4   | 30X3.0 | F37-612-30X3.0TFVCF                                       | 16.5 | 8.5  | IN12-30X3.0TFVCF                                | F37S12X                | OR25X1.0X            | 0.42                            |
| 3/4   | 30X4.0 | F37-612-30X4.0TFVCF                                       | 19.0 | 8.5  | IN12-30X4.0TFVCF                                | F37S12X                | OR22X1.0X            | 0.42                            |
| 1     | 25X2.5 | F37-616-25X2.5TFVCF                                       | 19.5 | 10.0 | IN16-25X2.5TFVCF                                | F37S16X                | OR20X1.0X            | 0.61                            |
| 1     | 25X3.0 | F37-616-25X3.0TFVCF                                       | 17.5 | 8.0  | IN16-25X3.0TFVCF                                | F37S16X                | OR20X1.0X            | 0.62                            |
| 1     | 30X3.0 | F37-616-30X3.0TFVCF                                       | 16.5 | 8.5  | IN16-30X3.0TFVCF                                | F37S16X                | OR25X1.0X            | 0.64                            |
| 1     | 30X4.0 | F37-616-30X4.0TFVCF                                       | 21.5 | 8.5  | IN16-30X4.0TFVCF                                | F37S16X                | OR22X1.0X            | 0.62                            |
| 1     | 38X2.5 | F37-616-38X2.5TFVCF                                       | 19.5 | 9.5  | IN16-38X2.5TFVCF                                | F37S16X                | OR34X1.0X            | 0.64                            |
| 1     | 38X3.0 | F37-616-38X3.0TFVCF                                       | 25.0 | 9.0  | IN16-38X3.0TFVCF                                | F37S16X                | OR34X1.0X            | 0.63                            |
| 1     | 38X4.0 | F37-616-38X4.0TFVCF                                       | 25.0 | 10.0 | IN16-38X4.0TFVCF                                | F37S16X                | OR30X1.0X            | 0.63                            |
| 1     | 38X5.0 | F37-616-38X5.0TFVCF                                       | 25.0 | 8.0  | IN16-38X5.0TFVCF                                | F37S16X                | OR28X1.0X            | 0.62                            |
| 1 1/4 | 30X3.0 | F37-620-30X3.0TFVCF                                       | 25.0 | 8.5  | IN20-30X3.0TFVCF                                | F37S20X                | OR25X1.0X            | 1.03                            |
| 1 1/4 | 30X4.0 | F37-620-30X4.0TFVCF                                       | 21.5 | 8.5  | IN20-30X4.0TFVCF                                | F37S20X                | OR22X1.0X            | 1.04                            |
| 1 1/4 | 38X3.0 | F37-620-38X3.0TFVCF                                       | 19.5 | 9.0  | IN20-38X3.0TFVCF                                | F37S20X                | OR34X1.0X            | 1.02                            |
| 1 1/4 | 38X4.0 | F37-620-38X4.0TFVCF                                       | 29.5 | 10.0 | IN20-38X4.0TFVCF                                | F37S20X                | OR30X1.0X            | 1.03                            |
| 1 1/4 | 38X5.0 | F37-620-38X5.0TFVCF                                       | 27.0 | 8.0  | IN20-38X5.0TFVCF                                | F37S20X                | OR28X1.0X            | 1.02                            |
| 1 1/4 | 42X3.0 | F37-620-42X3.0TFVCF                                       | 25.5 | 10.0 | IN20-42X3.0TFVCF                                | F37S20X                | OR37.82X1.78X        | 1.03                            |
| 1 1/4 | 42X4.0 | F37-620-42X4.0TFVCF                                       | 31.5 | 10.0 | IN20-42X4.0TFVCF                                | F37S20X                | OR34X1.0X            | 1.02                            |
| 1 1/2 | 38X3.0 | F37-624-38X3.0TFVCF                                       | 31.5 | 9.0  | IN24-38X3.0TFVCF                                | F37S24X                | OR34X1.0X            | 1.73                            |
| 1 1/2 | 38X4.0 | F37-624-38X4.0TFVCF                                       | 27.5 | 10.0 | IN24-38X4.0TFVCF                                | F37S24X                | OR30X1.0X            | 1.73                            |
| 1 1/2 | 38X5.0 | F37-624-38X5.0TFVCF                                       | 27.5 | 8.0  | IN24-38X5.0TFVCF                                | F37S24X                | OR28X1.0X            | 1.73                            |
| 1 1/2 | 42X3.0 | F37-624-42X3.0TFVCF                                       | 25.0 | 10.0 | IN24-42X3.0TFVCF                                | F37S24X                | OR37.82X1.78X        | 1.73                            |
| 1 1/2 | 42X4.0 | F37-624-42X4.0TFVCF                                       | 33.5 | 10.0 | IN24-42X4.0TFVCF                                | F37S24X                | OR34X1.0X            | 1.73                            |
| 1 1/2 | 50X3.0 | F37-624-50X3.0TFVCF                                       | 31.5 | 11.0 | IN24-50X3.0TFVCF                                | F37S24X                | OR44.17X1.78X        | 1.73                            |
| 1 1/2 | 50X5.0 | F37-624-50X5.0TFVCF                                       | 36.0 | 10.0 | IN24-50X5.0TFVCF                                | F37S24X                | OR41X1.78X           | 1.73                            |
| 1 1/2 | 50X6.0 | F37-624-50X6.0TFVCF                                       | 36.0 | 10.0 | IN24-50X6.0TFVCF                                | F37S24X                | OR41X1.78X           | 1.73                            |
| 2     | 50X3.0 | F37-632-50X3.0TFVCF                                       | 35.0 | 11.0 | IN32-50X3.0TFVCF                                | F37S32X                | OR44.17X1.78X        | 2.66                            |
| 2     | 50X5.0 | F37-632-50X5.0TFVCF                                       | 41.5 | 10.0 | IN32-50X5.0TFVCF                                | F37S32X                | OR41X1.78X           | 2.68                            |
| 2     | 50X6.0 | F37-632-50X6.0TFVCF                                       | 37.5 | 10.0 | IN32-50X6.0TFVCF                                | F37S32X                | OR41X1.78X           | 2.71                            |
| 2     | 60X3.0 | F37-632-60X3.0TFVCF                                       | 35.0 | 12.0 | IN32-60X3.0TFVCF                                | F37S32X                | OR53.7X1.78X         | 2.71                            |
| 2     | 60X5.0 | F37-632-60X5.0TFVCF                                       | 46.0 | 11.0 | IN32-60X5.0TFVCF                                | F37S32X                | OR50.52X1.78X        | 2.68                            |
| 2     | 60X6.0 | F37-632-60X6.0TFVCF                                       | 46.0 | 11.0 | IN32-60X6.0TFVCF                                | F37S32X                | OR47.37X1.78X        | 2.67                            |

Other sizes on request. \*Incl. adapter sleeve or jump size flange if necessary.

Please change suffixes according to material/surface required

| Order code suffixes             |                             |                     |
|---------------------------------|-----------------------------|---------------------|
| Material                        | Suffix surface and material | Example             |
| Steel, zinc plated, Cr(VI)-free | CF                          | F37-624-50X5.0TFVCF |
| Stainless steel                 | SS                          | F37-624-50X5.0TFVSS |

**TT – Flare connection**

Tube to tube connection

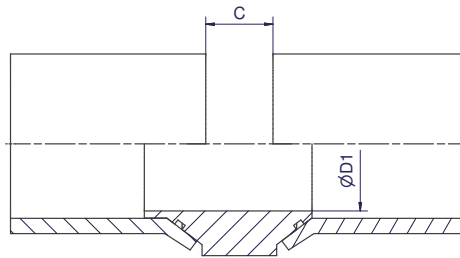
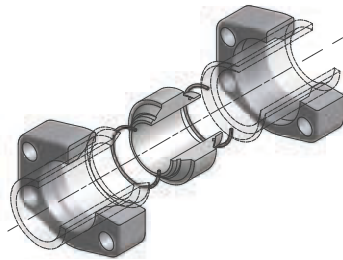

| Size  |        | 2 x Flanges* incl. Insert +<br>2 x O-Ring<br>Order code | D1   | C  | Insert incl. 2 x O-Ring<br>Order code | O-Ring<br>Order code | Weight<br>(Steel)<br>kg/1 piece |
|-------|--------|---|------|----|---------------------------------------|----------------------|---------------------------------|
| Inch  | Tube   |   |      |    |                                       |                      |                                 |
| 1/2   | 16X2.0 | <b>F37-608-16X2.0TTCF</b>                               | 9.5  | 16 | IN08-16X2.0TTCF                       | OR12X1.0X            | 0.28                            |
| 1/2   | 18X2.0 | <b>F37-608-18X2.0TTCF</b>                               | 11.5 | 16 | IN08-18X2.0TTCF                       | OR14X1.1X            | 0.29                            |
| 1/2   | 20X2.0 | <b>F37-608-20X2.0TTCF</b>                               | 13.5 | 16 | IN08-20X2.0TTCF                       | OR16X1.0X            | 0.29                            |
| 1/2   | 20X2.5 | <b>F37-608-20X2.5TTCF</b>                               | 13.5 | 16 | IN08-20X2.5TTCF                       | OR16X1.0X            | 0.29                            |
| 1/2   | 25X2.5 | <b>F37-608-25X2.5TTCF</b>                               | 13.5 | 20 | IN08-25X2.5TTCF                       | OR20X1.0X            | 0.30                            |
| 1/2   | 25X3.0 | <b>F37-608-25X3.0TTCF</b>                               | 13.5 | 16 | IN08-25X3.0TTCF                       | OR20X1.0X            | 0.29                            |
| 3/4   | 20X2.0 | <b>F37-612-20X2.0TTCF</b>                               | 13.5 | 16 | IN12-20X2.0TTCF                       | OR16X1.0X            | 0.48                            |
| 3/4   | 20X2.5 | <b>F37-612-20X2.5TTCF</b>                               | 12.5 | 16 | IN12-20X2.5TTCF                       | OR16X1.0X            | 0.48                            |
| 3/4   | 25X2.5 | <b>F37-612-25X2.5TTCF</b>                               | 17.5 | 20 | IN12-25X2.5TTCF                       | OR20X1.0X            | 0.49                            |
| 3/4   | 25X3.0 | <b>F37-612-25X3.0TTCF</b>                               | 16.5 | 16 | IN12-25X3.0TTCF                       | OR20X1.0X            | 0.49                            |
| 3/4   | 30X3.0 | <b>F37-612-30X3.0TTCF</b>                               | 19.0 | 17 | IN12-30X3.0TTCF                       | OR25X1.0X            | 0.50                            |
| 3/4   | 30X4.0 | <b>F37-612-30X4.0TTCF</b>                               | 19.5 | 17 | IN12-30X4.0TTCF                       | OR22X1.0X            | 0.50                            |
| 1     | 25X2.5 | <b>F37-616-25X2.5TTCF</b>                               | 17.5 | 20 | IN16-25X2.5TTCF                       | OR20X1.0X            | 0.72                            |
| 1     | 25X3.0 | <b>F37-616-25X3.0TTCF</b>                               | 16.5 | 16 | IN16-25X3.0TTCF                       | OR20X1.0X            | 0.72                            |
| 1     | 30X3.0 | <b>F37-616-30X3.0TTCF</b>                               | 21.5 | 17 | IN16-30X3.0TTCF                       | OR25X1.0X            | 0.71                            |
| 1     | 30X4.0 | <b>F37-616-30X4.0TTCF</b>                               | 19.5 | 17 | IN16-30X4.0TTCF                       | OR22X1.0X            | 0.72                            |
| 1     | 38X2.5 | <b>F37-616-38X2.5TTCF</b>                               | 25.0 | 19 | IN16-38X2.5TTCF                       | OR34X1.0X            | 0.77                            |
| 1     | 38X3.0 | <b>F37-616-38X3.0TTCF</b>                               | 25.0 | 18 | IN16-38X3.0TTCF                       | OR34X1.0X            | 0.75                            |
| 1     | 38X4.0 | <b>F37-616-38X4.0TTCF</b>                               | 25.0 | 20 | IN16-38X4.0TTCF                       | OR30X1.0X            | 0.73                            |
| 1     | 38X5.0 | <b>F37-616-38X5.0TTCF</b>                               | 25.0 | 16 | IN16-38X5.0TTCF                       | OR28X1.0X            | 0.71                            |
| 1 1/4 | 30X3.0 | <b>F37-620-30X3.0TTCF</b>                               | 21.5 | 17 | IN20-30X3.0TTCF                       | OR25X1.0X            | 1.16                            |
| 1 1/4 | 30X4.0 | <b>F37-620-30X4.0TTCF</b>                               | 19.5 | 17 | IN20-30X4.0TTCF                       | OR22X1.0X            | 1.19                            |
| 1 1/4 | 38X3.0 | <b>F37-620-38X3.0TTCF</b>                               | 25.0 | 18 | IN20-38X3.0TTCF                       | OR34X1.0X            | 1.14                            |
| 1 1/4 | 38X4.0 | <b>F37-620-38X4.0TTCF</b>                               | 27.0 | 20 | IN20-38X4.0TTCF                       | OR30X1.0X            | 1.15                            |
| 1 1/4 | 38X5.0 | <b>F37-620-38X5.0TTCF</b>                               | 25.5 | 16 | IN20-38X5.0TTCF                       | OR28X1.0X            | 1.13                            |
| 1 1/4 | 42X3.0 | <b>F37-620-42X3.0TTCF</b>                               | 31.5 | 20 | IN20-42X3.0TTCF                       | OR37.82X1.78X        | 1.14                            |
| 1 1/4 | 42X4.0 | <b>F37-620-42X4.0TTCF</b>                               | 31.5 | 20 | IN20-42X4.0TTCF                       | OR34X1.0X            | 1.13                            |
| 1 1/2 | 38X3.0 | <b>F37-624-38X3.0TTCF</b>                               | 27.5 | 18 | IN24-38X3.0TTCF                       | OR34X1.0X            | 1.79                            |
| 1 1/2 | 38X4.0 | <b>F37-624-38X4.0TTCF</b>                               | 27.5 | 20 | IN24-38X4.0TTCF                       | OR30X1.0X            | 1.79                            |
| 1 1/2 | 38X5.0 | <b>F37-624-38X5.0TTCF</b>                               | 25.0 | 16 | IN24-38X5.0TTCF                       | OR28X1.0X            | 1.79                            |
| 1 1/2 | 42X3.0 | <b>F37-624-42X3.0TTCF</b>                               | 33.5 | 20 | IN24-42X3.0TTCF                       | OR37.82X1.78X        | 1.84                            |
| 1 1/2 | 42X4.0 | <b>F37-624-42X4.0TTCF</b>                               | 31.5 | 20 | IN24-42X4.0TTCF                       | OR34X1.0X            | 1.94                            |
| 1 1/2 | 50X3.0 | <b>F37-624-50X3.0TTCF</b>                               | 36.0 | 22 | IN24-50X3.0TTCF                       | OR44.17X1.78X        | 1.96                            |
| 1 1/2 | 50X5.0 | <b>F37-624-50X5.0TTCF</b>                               | 36.0 | 20 | IN24-50X5.0TTCF                       | OR41X1.78X           | 2.07                            |
| 1 1/2 | 50X6.0 | <b>F37-624-50X6.0TTCF</b>                               | 35.0 | 20 | IN24-50X6.0TTCF                       | OR41X1.78X           | 1.96                            |
| 2     | 50X3.0 | <b>F37-632-50X3.0TTCF</b>                               | 41.5 | 22 | IN32-50X3.0TTCF                       | OR44.17X1.78X        | 2.86                            |
| 2     | 50X5.0 | <b>F37-632-50X5.0TTCF</b>                               | 37.5 | 20 | IN32-50X5.0TTCF                       | OR41X1.78X           | 2.97                            |
| 2     | 50X6.0 | <b>F37-632-50X6.0TTCF</b>                               | 35.0 | 20 | IN32-50X6.0TTCF                       | OR41X1.78X           | 3.02                            |
| 2     | 60X3.0 | <b>F37-632-60X3.0TTCF</b>                               | 46.0 | 24 | IN32-60X3.0TTCF                       | OR53.7X1.78X         | 2.99                            |
| 2     | 60X5.0 | <b>F37-632-60X5.0TTCF</b>                               | 46.0 | 22 | IN32-60X5.0TTCF                       | OR50.52X1.78X        | 2.92                            |
| 2     | 60X6.0 | <b>F37-632-60X6.0TTCF</b>                               | 45.5 | 22 | IN32-60X6.0TTCF                       | OR47.37X1.78X        | 2.91                            |

Other sizes on request. \*Incl. adapter sleeve or jump size flange if necessary.

Please change suffixes according to material/surface required

| Order code suffixes             |                             |                    |
|---------------------------------|-----------------------------|--------------------|
| Material                        | Suffix surface and material | Example            |
| Steel, zinc plated, Cr(VI)-free | CF                          | F37-624-50X5.0TTCF |
| Stainless steel                 | SS                          | F37-624-50X5.0TTSS |



**TF – Flare flange connection**

Tube to port connection, flat face

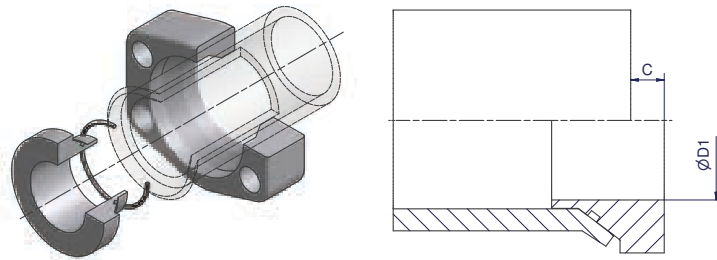

| Size  |        | Flange* incl. Insert +<br>O-Ring<br>Order code | D1   | C    | Insert incl. O-Ring<br>Order code | O-Ring<br>Order code | Weight<br>(Steel)<br>kg/1 piece |
|-------|--------|--|------|------|-----------------------------------|----------------------|---------------------------------|
| Inch  | Tube   |  |      |      |                                   |                      |                                 |
| 1/2   | 16X2.0 | F37-608-16X2.0TFCF                             | 9.5  | 8.0  | IN08-16X2.0TFCF                   | OR12X1.0X            | 0.24                            |
| 1/2   | 18X2.0 | F37-608-18X2.0TFCF                             | 11.5 | 8.0  | IN08-18X2.0TFCF                   | OR14X1.1X            | 0.24                            |
| 1/2   | 20X2.0 | F37-608-20X2.0TFCF                             | 13.5 | 8.0  | IN08-20X2.0TFCF                   | OR16X1.0X            | 0.25                            |
| 1/2   | 20X2.5 | F37-608-20X2.5TFCF                             | 13.5 | 8.0  | IN08-20X2.5TFCF                   | OR16X1.0X            | 0.25                            |
| 1/2   | 25X2.5 | F37-608-25X2.5TFCF                             | 13.5 | 10.0 | IN08-25X2.5TFCF                   | OR20X1.0X            | 0.25                            |
| 1/2   | 25X3.0 | F37-608-25X3.0TFCF                             | 13.0 | 8.0  | IN08-25X3.0TFCF                   | OR20X1.0X            | 0.24                            |
| 3/4   | 20X2.0 | F37-612-20X2.0TFCF                             | 13.5 | 8.0  | IN12-20X2.0TFCF                   | OR16X1.0X            | 0.41                            |
| 3/4   | 20X2.5 | F37-612-20X2.5TFCF                             | 12.5 | 8.0  | IN12-20X2.5TFCF                   | OR16X1.0X            | 0.41                            |
| 3/4   | 25X2.5 | F37-612-25X2.5TFCF                             | 17.5 | 10.0 | IN12-25X2.5TFCF                   | OR20X1.0X            | 0.41                            |
| 3/4   | 25X3.0 | F37-612-25X3.0TFCF                             | 16.5 | 8.0  | IN12-25X3.0TFCF                   | OR20X1.0X            | 0.42                            |
| 3/4   | 30X3.0 | F37-612-30X3.0TFCF                             | 19.0 | 8.5  | IN12-30X3.0TFCF                   | OR25X1.0X            | 0.42                            |
| 3/4   | 30X4.0 | F37-612-30X4.0TFCF                             | 19.5 | 8.5  | IN12-30X4.0TFCF                   | OR22X1.0X            | 0.42                            |
| 1     | 25X2.5 | F37-616-25X2.5TFCF                             | 17.5 | 10.0 | IN16-25X2.5TFCF                   | OR20X1.0X            | 0.61                            |
| 1     | 25X3.0 | F37-616-25X3.0TFCF                             | 16.5 | 8.0  | IN16-25X3.0TFCF                   | OR20X1.0X            | 0.62                            |
| 1     | 30X3.0 | F37-616-30X3.0TFCF                             | 21.5 | 8.5  | IN16-30X3.0TFCF                   | OR25X1.0X            | 0.64                            |
| 1     | 30X4.0 | F37-616-30X4.0TFCF                             | 19.5 | 8.5  | IN16-30X4.0TFCF                   | OR22X1.0X            | 0.62                            |
| 1     | 38X2.5 | F37-616-38X2.5TFCF                             | 25.0 | 9.5  | IN16-38X2.5TFCF                   | OR34X1.0X            | 0.64                            |
| 1     | 38X3.0 | F37-616-38X3.0TFCF                             | 25.0 | 9.0  | IN16-38X3.0TFCF                   | OR34X1.0X            | 0.63                            |
| 1     | 38X4.0 | F37-616-38X4.0TFCF                             | 25.0 | 10.0 | IN16-38X4.0TFCF                   | OR30X1.0X            | 0.63                            |
| 1     | 38X5.0 | F37-616-38X5.0TFCF                             | 25.0 | 8.0  | IN16-38X5.0TFCF                   | OR28X1.0X            | 0.62                            |
| 1 1/4 | 30X3.0 | F37-620-30X3.0TFCF                             | 21.5 | 8.5  | IN20-30X3.0TFCF                   | OR25X1.0X            | 1.03                            |
| 1 1/4 | 30X4.0 | F37-620-30X4.0TFCF                             | 19.5 | 8.5  | IN20-30X4.0TFCF                   | OR22X1.0X            | 1.05                            |
| 1 1/4 | 38X3.0 | F37-620-38X3.0TFCF                             | 29.0 | 9.0  | IN20-38X3.0TFCF                   | OR34X1.0X            | 1.02                            |
| 1 1/4 | 38X4.0 | F37-620-38X4.0TFCF                             | 27.0 | 10.0 | IN20-38X4.0TFCF                   | OR30X1.0X            | 1.03                            |
| 1 1/4 | 38X5.0 | F37-620-38X5.0TFCF                             | 25.5 | 8.0  | IN20-38X5.0TFCF                   | OR28X1.0X            | 1.02                            |
| 1 1/4 | 42X3.0 | F37-620-42X3.0TFCF                             | 31.5 | 10.0 | IN20-42X3.0TFCF                   | OR37.82X1.78X        | 1.03                            |
| 1 1/4 | 42X4.0 | F37-620-42X4.0TFCF                             | 31.5 | 10.0 | IN20-42X4.0TFCF                   | OR34X1.0X            | 1.02                            |
| 1 1/2 | 38X3.0 | F37-624-38X3.0TFCF                             | 27.5 | 9.0  | IN24-38X3.0TFCF                   | OR34X1.0X            | 1.73                            |
| 1 1/2 | 38X4.0 | F37-624-38X4.0TFCF                             | 27.5 | 10.0 | IN24-38X4.0TFCF                   | OR30X1.0X            | 1.73                            |
| 1 1/2 | 38X5.0 | F37-624-38X5.0TFCF                             | 25.0 | 8.0  | IN24-38X5.0TFCF                   | OR28X1.0X            | 1.73                            |
| 1 1/2 | 42X3.0 | F37-624-42X3.0TFCF                             | 33.5 | 10.0 | IN24-42X3.0TFCF                   | OR37.82X1.78X        | 1.73                            |
| 1 1/2 | 42X4.0 | F37-624-42X4.0TFCF                             | 31.5 | 10.0 | IN24-42X4.0TFCF                   | OR34X1.0X            | 1.73                            |
| 1 1/2 | 50X3.0 | F37-624-50X3.0TFCF                             | 36.0 | 11.0 | IN24-50X3.0TFCF                   | OR44.17X1.78X        | 1.73                            |
| 1 1/2 | 50X5.0 | F37-624-50X5.0TFCF                             | 36.0 | 10.0 | IN24-50X5.0TFCF                   | OR41X1.78X           | 1.73                            |
| 1 1/2 | 50X6.0 | F37-624-50X6.0TFCF                             | 35.0 | 10.0 | IN24-50X6.0TFCF                   | OR41X1.78X           | 1.73                            |
| 2     | 50X3.0 | F37-632-50X3.0TFCF                             | 41.5 | 11.0 | IN32-50X3.0TFCF                   | OR44.17X1.78X        | 2.66                            |
| 2     | 50X5.0 | F37-632-50X5.0TFCF                             | 37.5 | 10.0 | IN32-50X5.0TFCF                   | OR41X1.78X           | 2.68                            |
| 2     | 50X6.0 | F37-632-50X6.0TFCF                             | 35.0 | 10.0 | IN32-50X6.0TFCF                   | OR41X1.78X           | 2.71                            |
| 2     | 60X3.0 | F37-632-60X3.0TFCF                             | 46.0 | 12.0 | IN32-60X3.0TFCF                   | OR53.7X1.78X         | 2.71                            |
| 2     | 60X5.0 | F37-632-60X5.0TFCF                             | 46.0 | 11.0 | IN32-60X5.0TFCF                   | OR50.52X1.78X        | 2.68                            |
| 2     | 60X6.0 | F37-632-60X6.0TFCF                             | 45.5 | 11.0 | IN32-60X6.0TFCF                   | OR47.37X1.78X        | 2.67                            |

Other sizes on request. \*Incl. adapter sleeve or jump size flange if necessary.

Please change suffixes according to material/surface required

| Order code suffixes             |                             |                    |
|---------------------------------|-----------------------------|--------------------|
| Material                        | Suffix surface and material | Example            |
| Steel, zinc plated, Cr(VI)-free | CF                          | F37-624-50X5.0TFCF |
| Stainless steel                 | SS                          | F37-624-50X5.0TFSS |

**SL – Sleeve**

SAE 6000/ISO 6162-2

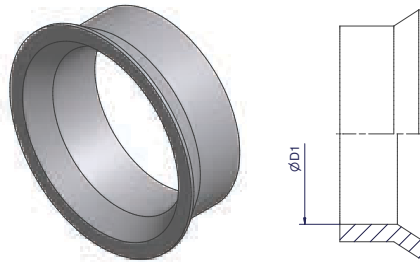

| Size<br>Inch | Tube OD | Order code             | D1   | Weight<br>(Steel)<br>kg/1 piece |
|--------------|---------|------------------------|------|---------------------------------|
| 1/2          | 16      | <b>SL08-25-16-CFX</b>  | 16.3 | 0.04                            |
| 1/2          | 18      | <b>SL08-25-18-CFX</b>  | 18.3 | 0.04                            |
| 1/2          | 20      | <b>SL08-25-20-CFX</b>  | 20.3 | 0.04                            |
| 3/4          | 20      | <b>SL12-30-20-CFX</b>  | 20.3 | 0.04                            |
| 3/4          | 25      | <b>SL12-30-25-CFX*</b> | 25.2 | 0.04                            |
| 1            | 25      | <b>SL16-38-25-CFX*</b> | 25.2 | 0.04                            |
| 1            | 30      | <b>SL16-38-30-CFX*</b> | 30.2 | 0.04                            |
| 1 1/4        | 30      | <b>SL20-42-30-CFX</b>  | 30.2 | 0.04                            |
| 1 1/4        | 38      | <b>SL20-42-38-CFX*</b> | 38.3 | 0.04                            |
| 1 1/2        | 38      | <b>SL24-50-38-CFX</b>  | 38.3 | 0.14                            |
| 1 1/2        | 42      | <b>SL24-50-42-CFX*</b> | 42.3 | 0.10                            |
| 2            | 50      | <b>SL32-60-50-CFX*</b> | 50.3 | 0.16                            |

\*By use of jump size flanges, no adapter sleeves necessary. For jump size flanges see page 118.

Please change suffixes according to material/surface required

| Order code suffixes             |                             |                |
|---------------------------------|-----------------------------|----------------|
| Material                        | Suffix surface and material | Example        |
| Steel, zinc plated, Cr(VI)-free | CF                          | SL24-50-42-CFX |
| Stainless steel                 | SS                          | SL24-50-42-SSX |



## R – Retaining ring

SAE 6000/ISO 6162-2

| Size<br>Inch | Tube   | D    | S   | Order code  |
|--------------|--------|------|-----|-------------|
| 1/2          | 26X6.0 | 22.3 | 4.0 | <b>R08X</b> |
| 3/4          | 36X8.0 | 32.3 | 4.0 | <b>R12X</b> |
| 1            | 39X7.5 | 34.3 | 5.0 | <b>R16X</b> |
| 1 1/4        | 46X8.0 | 41.3 | 5.0 | <b>R20X</b> |
| 1 1/2        | 56X8.5 | 51.3 | 5.0 | <b>R24X</b> |
| 2            | 66X8.5 | 61.3 | 5.0 | <b>R32X</b> |

Material: Stainless steel

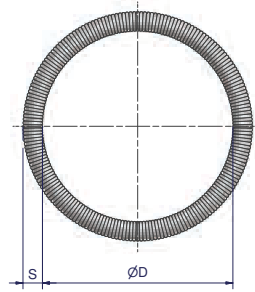

**MTF-R – Male thread adapter, BSPP**

SAE 6000/ISO 6162-2

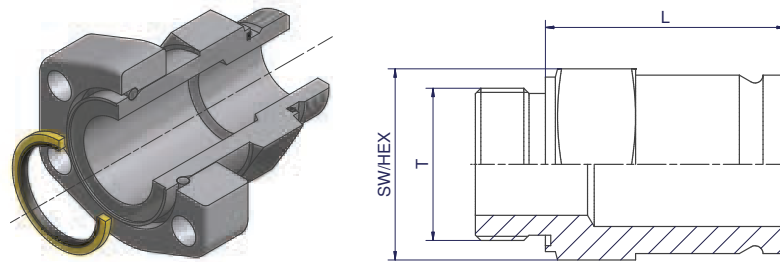

| Size Inch | Tube   | Complete part Order code | Body incl. ED Seal Order code | Weight body (Steel) kg/1 piece | L     | T (BSPP)  | SW/ HEX |
|-----------|--------|--------------------------|-------------------------------|--------------------------------|-------|-----------|---------|
| 3/4       | 36X8.0 | <b>R-612MTFRCF</b>       | MTF12ROMDCF                   | 0.32                           | 61.0  | G 3/4 A   | 36      |
| 3/4       | 36X8.0 | <b>R-612MTFR1/2CF</b>    | MTF12R1/2OMDCF                | 0.32                           | 61.0  | G 1/2 A   | 36      |
| 1         | 39X7.5 | <b>R-616MTFRCF</b>       | MTF16ROMDCF                   | 0.50                           | 69.0  | G 1 A     | 41      |
| 1         | 39X7.5 | <b>R-616MTFR3/4CF</b>    | MTF16R3/4OMDCF                | 0.50                           | 69.0  | G 3/4 A   | 41      |
| 1 1/4     | 46X8.0 | <b>R-620MTFRCF</b>       | MTF20ROMDCF                   | 0.75                           | 80.0  | G 1 1/4 A | 50      |
| 1 1/4     | 46X8.0 | <b>R-620MTFR1CF</b>      | MTF20R1OMDCF                  | 0.75                           | 80.0  | G 1 A     | 50      |
| 1 1/2     | 56X8.5 | <b>R-624MTFRCF</b>       | MTF24ROMDCF                   | 1.80                           | 93.0  | G 1 1/2 A | 60      |
| 1 1/2     | 56X8.5 | <b>R-624MTFR11/4CF</b>   | MTF24R11/4OMDCF               | 1.80                           | 93.0  | G 1 1/4 A | 60      |
| 2         | 66X8.5 | <b>R-632MTFRCF</b>       | MTF32ROMDCF                   | 2.50                           | 104.0 | G 2 A     | 75      |
| 2         | 66X8.5 | <b>R-632MTFR11/2CF</b>   | MTF32R11/2OMDCF               | 2.50                           | 104.0 | G 1 1/2 A | 75      |

Other sizes on request

Please change suffixes according to material/surface required

| Order code suffixes             |                             |             |
|---------------------------------|-----------------------------|-------------|
| Material                        | Suffix surface and material | Example     |
| Steel, zinc plated, Cr(VI)-free | CF                          | MTF20ROMDCF |
| Stainless steel                 | SS                          | MTF20ROMDSS |





## MTF-N – Male thread adapter, NPT

SAE 6000/ISO 6162-2

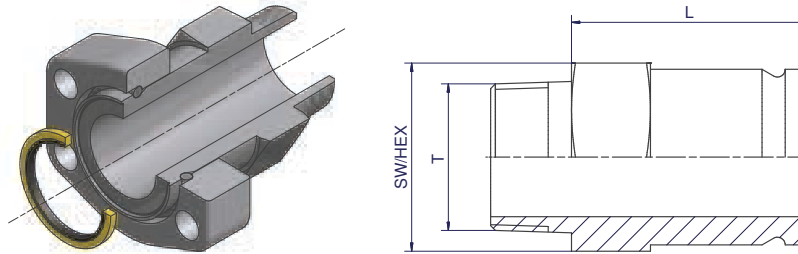

| Size Inch | Tube   | Complete part Order code | Body Order code | Weight body (Steel) kg/1 piece | L     | T (NPT)    | SW/HEX |
|-----------|--------|--------------------------|-----------------|--------------------------------|-------|------------|--------|
| 1/2       | 26X6.0 | <b>R-608MTFNCF</b>       | MTF08NCFX       | 0.26                           | 72.6  | 1/2-14     | 27     |
| 3/4       | 36X8.0 | <b>R-612MTFNCF</b>       | MTF12NCFX       | 0.48                           | 72.6  | 3/4-14     | 36     |
| 1         | 39X7.5 | <b>R-616MTFNCF</b>       | MTF16NCFX       | 0.45                           | 67.7  | 1-11.5     | 41     |
| 1 1/4     | 46X8.0 | <b>R-620MTFNCF</b>       | MTF20NCFX       | 0.70                           | 75.0  | 1 1/4-11.5 | 50     |
| 1 1/2     | 56X8.5 | <b>R-624MTFNCF</b>       | MTF24NCFX       | 1.80                           | 93.2  | 1 1/2-11.5 | 60     |
| 2         | 66X8.5 | <b>R-632MTFNCF</b>       | MTF32NCFX       | 2.40                           | 100.4 | 2-11.5     | 75     |

Other sizes on request

Please change suffixes according to material/surface required

| Order code suffixes             |                             |            |
|---------------------------------|-----------------------------|------------|
| Material                        | Suffix surface and material | Example    |
| Steel, zinc plated, Cr(VI)-free | CF                          | MTF20NCFX  |
| Stainless steel                 | SS                          | MTF20NCFSS |

**FTF-R – Female thread adapter, BSPP**

SAE 6000/ISO 6162-2

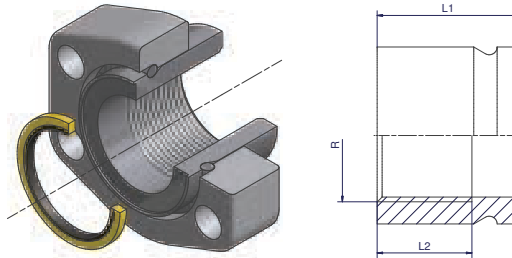

| Size Inch | Tube   | Complete part Order code | Body Order code | Weight body (Steel) kg/1 piece | L1 | L2 | R (BSPP) |
|-----------|--------|--------------------------|-----------------|--------------------------------|----|----|----------|
| 1/2       | 26X6.0 | <b>R-608FTFRCF</b>       | FTF08RCFX       | 0.11                           | 35 | 25 | G 1/4    |
| 3/4       | 36X8.0 | <b>R-612FTFRCF</b>       | FTF12RCFX       | 0.22                           | 40 | 25 | G 1/2    |
| 1         | 39X7.5 | <b>R-616FTFRCF</b>       | FTF16RCFX       | 0.20                           | 40 | 25 | G 3/4    |
| 1 1/4     | 46X8.0 | <b>R-620FTFRCF</b>       | FTF20RCFX       | 0.30                           | 42 | 30 | G 1      |
| 1 1/2     | 56X8.5 | <b>R-624FTFRCF</b>       | FTF24RCFX       | 0.45                           | 45 | 30 | G 1 1/4  |
| 2         | 66X8.5 | <b>R-632FTFRCF</b>       | FTF32RCFX       | 0.75                           | 55 | 40 | G 1 1/2  |

Other sizes on request

Please change suffixes according to material/surface required



| Order code suffixes             |                             |            |
|---------------------------------|-----------------------------|------------|
| Material                        | Suffix surface and material | Example    |
| Steel, zinc plated, Cr(VI)-free | CF                          | FTF20RCFX  |
| Stainless steel                 | SS                          | FTF20RCFSS |





## Retaining ring hose couplings

SAE 6000/ISO 6162-2

One Piece No-Skive Hose fittings 48 Series for Parker hose types 301SN (2 wire braid) & 421SN (one wire braid)

|            |       |  |  |  |
|------------|-------|---|---|---|
| Connection |       | Order code  | Order code  | Order code  |
| Flange     | Hose  |   |   |   |
| 1 1/4      | 1 1/4 | <b>1X548-20-20</b>  | <b>1X748-20-20</b>  | <b>1X948-20-20</b>  |
| 1 1/2      | 1 1/2 | <b>1X548-24-24</b>  | <b>1X748-24-24</b>  | <b>1X948-24-24</b>  |
| 2          | 2     | <b>1X548-32-32</b>  | <b>1X748-32-32</b>  | <b>1X948-32-32</b>  |

Interlock Hose nipples V6 series for Parker hose types H82 & R42 (6 spiral)

|            |       |  |  |  |
|------------|-------|--|--|--|
| Connection |       | Order code   | Order code   | Order code   |
| Flange     | Hose  |  |  |  |
| 1 1/4      | 1 1/4 | <b>KX5V6-20-20</b>   | <b>KX7V6-20-20</b>   | <b>KX9V6-20-20</b>   |
| 1 1/2      | 1 1/2 | <b>KX5V6-24-24</b>   | <b>KX7V6-24-24</b>   | <b>KX9V6-24-24</b>   |
| 2          | 2     | <b>KX5V6-32-32</b>   | <b>KX7V6-32-32</b>   | <b>KX9V6-32-32</b>   |

Interlock Shells V6 Series for Parker hose types H82 & R42

|            |  |  |
|------------|--|---|
| Connection |  | Order code  |
| Hose       |  |   |
| 1 1/4      |  | <b>100V6-20</b>   |
| 1 1/2      |  | <b>100V6-24</b>   |
| 2          |  | <b>100V6-32</b>   |

**WA – Weld adapter connection**

SAE 6000/ISO 6162-2

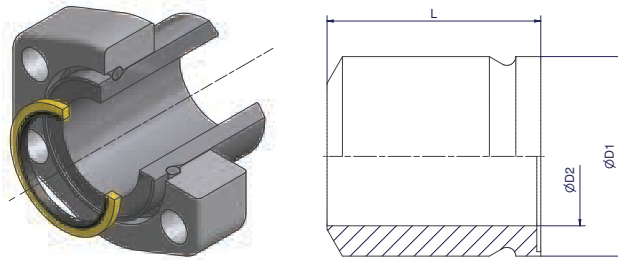

| Size Inch | Tube     | Complete Part Order code | Retaining Ring | Bonded Seal | Flange Order code | Weld Adapter Body Order code | Weight (Steel) kg/1 piece | D1 | D2 | L  |
|-----------|----------|--------------------------|----------------|-------------|-------------------|------------------------------|---------------------------|----|----|----|
| 1/2       | 12X1.5   | <b>R-608WA-12X1.5S</b>   | R08X           | BS08SNX     | R-608-CFX         | WA08-12X1.5SX                | 0.29                      | 26 | 14 | 40 |
| 1/2       | 16X2.0   | <b>R-608WA-16X2.0S</b>   | R08X           | BS08SNX     | R-608-CFX         | WA08-16X2.0SX                | 0.30                      | 26 | 14 | 40 |
| 1/2       | 18X2.0   | <b>R-608WA-18X2.0S</b>   | R08X           | BS08SNX     | R-608-CFX         | WA08-18X2.0SX                | 0.30                      | 26 | 14 | 40 |
| 1/2       | 20X2.0   | <b>R-608WA-20X2.5S</b>   | R08X           | BS08SNX     | R-608-CFX         | WA08-20X2.5SX                | 0.30                      | 26 | 14 | 40 |
| 1/2       | 21.3X2.1 | <b>R-608WA-21.3X2.1S</b> | R08X           | BS08SNX     | R-608-CFX         | WA08-21.3X2.1SX              | 0.30                      | 26 | 14 | 40 |
| 1/2       | 21.3X2.8 | <b>R-608WA-21.3X2.8S</b> | R08X           | BS08SNX     | R-608-CFX         | WA08-21.3X2.8SX              | 0.30                      | 26 | 14 | 40 |
| 1/2       | 21.3X3.7 | <b>R-608WA-21.3X3.7S</b> | R08X           | BS08SNX     | R-608-CFX         | WA08-21.3X3.7SX              | 0.31                      | 26 | 14 | 45 |
| 1/2       | 21.3X4.8 | <b>R-608WA-21.3X4.8S</b> | R08X           | BS08SNX     | R-608-CFX         | WA08-21.3X4.8SX              | 0.32                      | 26 | 14 | 45 |
| 1/2       | 21.3X7.5 | <b>R-608WA-21.3X7.5S</b> | R08X           | BS08SNX     | R-608-CFX         | WA08-21.3X7.5SX              | 0.32                      | 26 | 14 | 45 |
| 1/2       | 25X2.5   | <b>R-608WA-25X2.5S</b>   | R08X           | BS08SNX     | R-608-CFX         | WA08-25X2.5SX                | 0.29                      | 26 | 14 | 40 |
| 1/2       | 26X6.0   | <b>R-608WA-26X6.0S</b>   | R08X           | BS08SNX     | R-608-CFX         | WA08-26X6.0SX                | 0.31                      | 26 | 14 | 40 |
| 3/4       | 20X2.5   | <b>R-612WA-20X2.5S</b>   | R12X           | BS12SNX     | R-612-CFX         | WA12-20X2.5SX                | 0.41                      | 36 | 20 | 45 |
| 3/4       | 25X3.0   | <b>R-612WA-25X3.0S</b>   | R12X           | BS12SNX     | R-612-CFX         | WA12-25X3.0SX                | 0.41                      | 36 | 20 | 45 |
| 3/4       | 26.7X2.1 | <b>R-612WA-26.7X2.1S</b> | R12X           | BS12SNX     | R-612-CFX         | WA12-26.7X2.1SX              | 0.40                      | 36 | 20 | 45 |
| 3/4       | 26.7X2.8 | <b>R-612WA-26.7X2.8S</b> | R12X           | BS12SNX     | R-612-CFX         | WA12-26.7X2.8SX              | 0.41                      | 36 | 20 | 45 |
| 3/4       | 26.7X3.9 | <b>R-612WA-26.7X3.9S</b> | R12X           | BS12SNX     | R-612-CFX         | WA12-26.7X3.9SX              | 0.41                      | 36 | 20 | 45 |
| 3/4       | 26.7X5.6 | <b>R-612WA-26.7X5.6S</b> | R12X           | BS12SNX     | R-612-CFX         | WA12-26.7X5.6SX              | 0.44                      | 36 | 20 | 50 |
| 3/4       | 26.7X7.8 | <b>R-612WA-26.7X7.8S</b> | R12X           | BS12SNX     | R-612-CFX         | WA12-26.7X7.8SX              | 0.45                      | 36 | 20 | 50 |
| 3/4       | 30X3.0   | <b>R-612WA-30X3.0S</b>   | R12X           | BS12SNX     | R-612-CFX         | WA12-30X3.0SX                | 0.41                      | 36 | 20 | 50 |
| 3/4       | 30X4.0   | <b>R-612WA-30X4.0S</b>   | R12X           | BS12SNX     | R-612-CFX         | WA12-30X4.0SX                | 0.42                      | 36 | 20 | 50 |
| 3/4       | 30X6.0   | <b>R-612WA-30X6.0S</b>   | R12X           | BS12SNX     | R-612-CFX         | WA12-30X6.0SX                | 0.44                      | 36 | 20 | 50 |
| 3/4       | 36X8.0   | <b>R-612WA-36X8.0S</b>   | R12X           | BS12SNX     | R-612-CFX         | WA12-36X8.0SX                | 0.46                      | 36 | 20 | 50 |
| 1         | 25X3.0   | <b>R-616WA-25X3.0S</b>   | R16X           | BS16SNX     | R-616-CFX         | WA16-25X3.0SX                | 0.66                      | 39 | 19 | 60 |
| 1         | 30X4.0   | <b>R-616WA-30X4.0S</b>   | R16X           | BS16SNX     | R-616-CFX         | WA16-30X4.0SX                | 0.65                      | 39 | 20 | 60 |
| 1         | 33.4X2.8 | <b>R-616WA-33.4X2.8S</b> | R16X           | BS16SNX     | R-616-CFX         | WA16-33.4X2.8SX              | 0.61                      | 39 | 24 | 60 |
| 1         | 33.4X3.4 | <b>R-616WA-33.4X3.4S</b> | R16X           | BS16SNX     | R-616-CFX         | WA16-33.4X3.4SX              | 0.62                      | 39 | 24 | 60 |
| 1         | 33.4X4.6 | <b>R-616WA-33.4X4.6S</b> | R16X           | BS16SNX     | R-616-CFX         | WA16-33.4X4.6SX              | 0.64                      | 39 | 24 | 60 |
| 1         | 33.4X6.5 | <b>R-616WA-33.4X6.5S</b> | R16X           | BS16SNX     | R-616-CFX         | WA16-33.4X6.5SX              | 0.70                      | 39 | 20 | 60 |
| 1         | 33.4X9.1 | <b>R-616WA-33.4X9.1S</b> | R16X           | BS16SNX     | R-616-CFX         | WA16-33.4X9.1SX              | 0.69                      | 39 | 24 | 60 |
| 1         | 38X4.0   | <b>R-616WA-38X4.0S</b>   | R16X           | BS16SNX     | R-616-CFX         | WA16-38X4.0SX                | 0.59                      | 39 | 24 | 55 |
| 1         | 38X5.0   | <b>R-616WA-38X5.0S</b>   | R16X           | BS16SNX     | R-616-CFX         | WA16-38X5.0SX                | 0.61                      | 39 | 24 | 55 |
| 1         | 38X7.0   | <b>R-616WA-38X7.0S</b>   | R16X           | BS16SNX     | R-616-CFX         | WA16-38X7.0SX                | 0.67                      | 39 | 24 | 60 |
| 1         | 39X7.5   | <b>R-616WA-39X7.5S</b>   | R16X           | BS16SNX     | R-616-CFX         | WA16-39X7.5SX                | 0.62                      | 39 | 24 | 50 |
| 1 1/4     | 30X4.0   | <b>R-620WA-30X4.0S</b>   | R20X           | BS20SNX     | R-620-CFX         | WA20-30X4.0SX                | 1.06                      | 46 | 22 | 70 |
| 1 1/4     | 38X4.0   | <b>R-620WA-38X4.0S</b>   | R20X           | BS20SNX     | R-620-CFX         | WA20-38X4.0SX                | 0.91                      | 46 | 30 | 65 |
| 1 1/4     | 38X5.0   | <b>R-620WA-38X5.0S</b>   | R20X           | BS20SNX     | R-620-CFX         | WA20-38X5.0SX                | 0.96                      | 46 | 28 | 65 |
| 1 1/4     | 42X3.0   | <b>R-620WA-42X3.0S</b>   | R20X           | BS20SNX     | R-620-CFX         | WA20-42X3.0SX                | 0.86                      | 46 | 30 | 65 |
| 1 1/4     | 42X4.0   | <b>R-620WA-42X4.0S</b>   | R20X           | BS20SNX     | R-620-CFX         | WA20-42X4.0SX                | 0.89                      | 46 | 30 | 65 |
| 1 1/4     | 42X6.0   | <b>R-620WA-42X6.0S</b>   | R20X           | BS20SNX     | R-620-CFX         | WA20-42X6.0SX                | 0.95                      | 46 | 30 | 65 |
| 1 1/4     | 42.2X2.7 | <b>R-620WA-42.2X2.7S</b> | R20X           | BS20SNX     | R-620-CFX         | WA20-42.2X2.7SX              | 0.85                      | 46 | 30 | 65 |
| 1 1/4     | 42.2X3.6 | <b>R-620WA-42.2X3.6S</b> | R20X           | BS20SNX     | R-620-CFX         | WA20-42.2X3.6SX              | 0.88                      | 46 | 30 | 65 |
| 1 1/4     | 42.2X4.9 | <b>R-620WA-42.2X4.9S</b> | R20X           | BS20SNX     | R-620-CFX         | WA20-42.2X4.9SX              | 0.92                      | 46 | 30 | 65 |
| 1 1/4     | 42.2X6.4 | <b>R-620WA-42.2X6.4S</b> | R20X           | BS20SNX     | R-620-CFX         | WA20-42.2X6.4SX              | 0.96                      | 46 | 29 | 65 |
| 1 1/4     | 42.2X9.7 | <b>R-620WA-42.2X9.7S</b> | R20X           | BS20SNX     | R-620-CFX         | WA20-42.2X9.7SX              | 1.08                      | 46 | 23 | 65 |
| 1 1/4     | 46X7.0   | <b>R-620WA-46X7.0S</b>   | R20X           | BS20SNX     | R-620-CFX         | WA20-46X7.0SX                | 0.97                      | 46 | 30 | 65 |
| 1 1/4     | 46X8.0   | <b>R-620WA-46X8.0S</b>   | R20X           | BS20SNX     | R-620-CFX         | WA20-46X8.0SX                | 0.90                      | 46 | 30 | 55 |

See next page

**WA – Weld adapter connection** continued

SAE 6000/ISO 6162-2

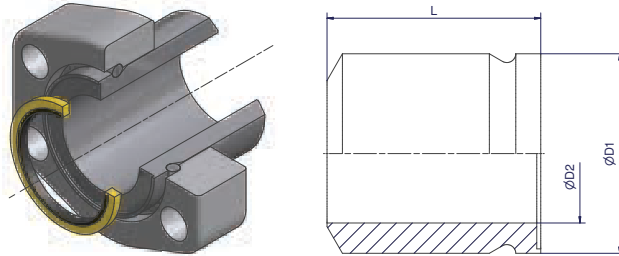

| Size Inch | Tube      | Complete Part Order code  | Retaining Ring | Bonded Seal | Flange Order code | Weld Adapter Body Order code | Weight (Steel) kg/1 piece | D1 | D2 | L  |
|-----------|-----------|---------------------------|----------------|-------------|-------------------|------------------------------|---------------------------|----|----|----|
| 1 1/2     | 38X5.0    | <b>R-624WA-38X5.0S</b>    | R24X           | BS24SNX     | R-624-CFX         | WA24-38X5.0SX                | 1.48                      | 56 | 28 | 75 |
| 1 1/2     | 48.3X2.8  | <b>R-624WA-48.3X2.8S</b>  | R24X           | BS24SNX     | R-624-CFX         | WA24-48.3X2.8SX              | 1.14                      | 56 | 39 | 70 |
| 1 1/2     | 48.3X3.7  | <b>R-624WA-48.3X3.7S</b>  | R24X           | BS24SNX     | R-624-CFX         | WA24-48.3X3.7SX              | 1.18                      | 56 | 39 | 70 |
| 1 1/2     | 48.3X5.1  | <b>R-624WA-48.3X5.1S</b>  | R24X           | BS24SNX     | R-624-CFX         | WA24-48.3X5.1SX              | 1.24                      | 56 | 38 | 70 |
| 1 1/2     | 48.3X7.1  | <b>R-624WA-48.3X7.1S</b>  | R24X           | BS24SNX     | R-624-CFX         | WA24-48.3X7.1SX              | 1.36                      | 56 | 34 | 70 |
| 1 1/2     | 48.3X10.2 | <b>R-624WA-48.3X10.2S</b> | R24X           | BS24SNX     | R-624-CFX         | WA24-48.3X10.2SX             | 1.32                      | 56 | 30 | 70 |
| 1 1/2     | 50X3.0    | <b>R-624WA-50X3.0S</b>    | R24X           | BS24SNX     | R-624-CFX         | WA24-50X3.0SX                | 1.13                      | 56 | 39 | 70 |
| 1 1/2     | 50X5.0    | <b>R-624WA-50X5.0S</b>    | R24X           | BS24SNX     | R-624-CFX         | WA24-50X5.0SX                | 1.20                      | 56 | 40 | 70 |
| 1 1/2     | 50X6.0    | <b>R-624WA-50X6.0S</b>    | R24X           | BS24SNX     | R-624-CFX         | WA24-50X6.0SX                | 1.26                      | 56 | 38 | 70 |
| 1 1/2     | 50x9.0    | <b>R-624WA-50X9.0S</b>    | R24X           | BS24SNX     | R-624-CFX         | WA24-50X9.0SX                | 1.42                      | 56 | 32 | 70 |
| 1 1/2     | 56X8.5    | <b>R-624WA-56X8.5S</b>    | R24X           | BS24SNX     | R-624-CFX         | WA24-56X8.5SX                | 1.18                      | 56 | 39 | 60 |
| 2         | 48.3X5.6  | <b>R-632WA-48.3X5.6S</b>  | R32X           | BS32SNX     | R-632-CFX         | WA32-48.3X5.6SX              | 2.40                      | 66 | 37 | 90 |
| 2         | 50X9.0    | <b>R-632WA-50X9.0S</b>    | R32X           | BS32SNX     | R-632-CFX         | WA32-50X9.0SX                | 2.61                      | 66 | 32 | 90 |
| 2         | 60X3.0    | <b>R-632WA-60X3.0S</b>    | R32X           | BS32SNX     | R-632-CFX         | WA32-60X3.0SX                | 1.89                      | 66 | 49 | 90 |
| 2         | 60X5.0    | <b>R-632WA-60X5.0S</b>    | R32X           | BS32SNX     | R-632-CFX         | WA32-60X5.0SX                | 1.99                      | 66 | 50 | 90 |
| 2         | 60X6.0    | <b>R-632WA-60X6.0S</b>    | R32X           | BS32SNX     | R-632-CFX         | WA32-60X6.0SX                | 2.10                      | 66 | 48 | 90 |
| 2         | 60X8.0    | <b>R-632WA-60X8.0S</b>    | R32X           | BS32SNX     | R-632-CFX         | WA32-60X8.0SX                | 2.28                      | 66 | 44 | 90 |
| 2         | 60x10.0   | <b>R-632WA-60X10.0S</b>   | R32X           | BS32SNX     | R-632-CFX         | WA32-60X10.0SX               | 2.46                      | 66 | 40 | 90 |
| 2         | 60.3X2.8  | <b>R-632WA-60.3X2.8S</b>  | R32X           | BS32SNX     | R-632-CFX         | WA32-60.3X2.8SX              | 1.87                      | 66 | 49 | 90 |
| 2         | 60.3X3.9  | <b>R-632WA-60.3X3.9S</b>  | R32X           | BS32SNX     | R-632-CFX         | WA32-60.3X3.9SX              | 1.95                      | 66 | 49 | 90 |
| 2         | 60.3X5.5  | <b>R-632WA-60.3X5.5S</b>  | R32X           | BS32SNX     | R-632-CFX         | WA32-60.3X5.5SX              | 2.04                      | 66 | 49 | 90 |
| 2         | 60.3X8.7  | <b>R-632WA-60.3X8.7S</b>  | R32X           | BS32SNX     | R-632-CFX         | WA32-60.3X8.7SX              | 2.34                      | 66 | 43 | 90 |
| 2         | 60.3X11.1 | <b>R-632WA-60.3X11.1S</b> | R32X           | BS32SNX     | R-632-CFX         | WA32-60.3X11.1SX             | 2.54                      | 66 | 38 | 90 |
| 2         | 66X8.5    | <b>R-632WA-66X8.5S</b>    | R32X           | BS32SNX     | R-632-CFX         | WA32-66X8.5SX                | 1.95                      | 66 | 49 | 75 |

Other sizes on request

Please change suffixes according to material/surface required

| Order code suffixes |                             |                  |
|---------------------|-----------------------------|------------------|
| Material            | Suffix surface and material | Example          |
| Steel               | S                           | R-620WA-46X8.0S  |
| Stainless steel     | SS                          | R-620WA-46X8.0SS |

**BF – Bulkhead flange**

SAE 6000/ISO 6162-2

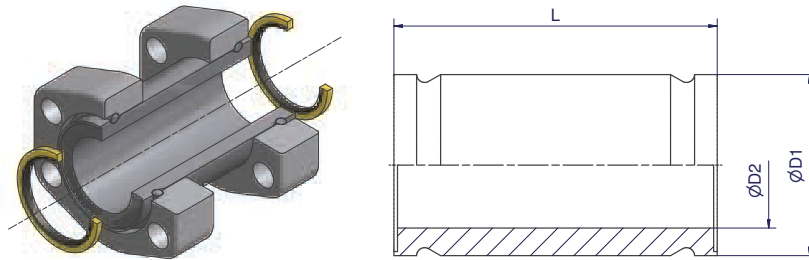

| Size<br>Inch | D1 | D2 | L   | Complete Part<br>Order code | Bulkhead Body<br>Order code | Weight body (Steel)<br>kg/1 piece |
|--------------|----|----|-----|-----------------------------|-----------------------------|-----------------------------------|
| 1            | 39 | 24 | 170 | <b>R-616BFS</b>             | BF16SX                      | 0.96                              |
| 1 1/4        | 46 | 30 | 180 | <b>R-620BFS</b>             | BF20SX                      | 1.30                              |
| 1 1/2        | 56 | 39 | 180 | <b>R-624BFS</b>             | BF24SX                      | 1.75                              |
| 2            | 66 | 49 | 210 | <b>R-632BFS</b>             | BF32SX                      | 2.45                              |

Other sizes on request

Please change suffixes according to material/surface required

| Order code suffixes |                                |           |
|---------------------|--------------------------------|-----------|
| Material            | Suffix surface<br>and material | Example   |
| Steel               | S                              | R-620BFS  |
| Stainless steel     | SS                             | R-620BFSS |



**VB – Vibra bulkhead**

SAE 6000/ISO 6162-2

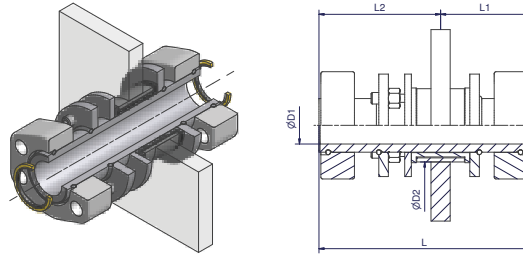

| Size Inch | Tube   | D1 | D2   | L   | L1  | L2  | Complete Part Order code | Weight (Steel) kg/1 piece |
|-----------|--------|----|------|-----|-----|-----|--------------------------|---------------------------|
| 1         | 39X7.5 | 24 | 59.5 | 220 | 95  | 125 | <b>R-616VBCF</b>         | 3.20                      |
| 1 1/4     | 46X8.0 | 30 | 66.5 | 220 | 95  | 125 | <b>R-620VBCF</b>         | 4.10                      |
| 1 1/2     | 56X8.5 | 39 | 76.5 | 220 | 95  | 125 | <b>R-624VBCF</b>         | 4.90                      |
| 2         | 66X8.5 | 49 | 86.5 | 250 | 110 | 140 | <b>R-632VBCF</b>         | 6.19                      |

Other sizes on request

Please change suffixes according to material/surface required

| Order code suffixes             |                             |           |
|---------------------------------|-----------------------------|-----------|
| Material                        | Suffix surface and material | Example   |
| Steel, zinc plated, Cr(VI)-free | CF                          | R-620VBCF |
| Stainless steel                 | SS                          | R-620VBSS |



**RF – Reducer flange**

SAE 6000/ISO 6162-2

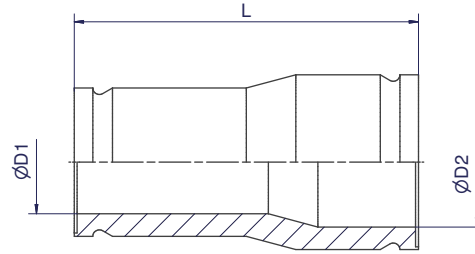
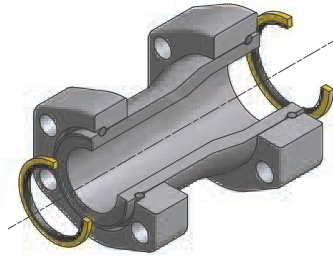

| Size<br>Inch  | D1 | D2 | L   | Complete Part<br>Order code | Reducer Body<br>Order code | Weight body<br>(Steel)<br>kg/1 piece |
|---------------|----|----|-----|-----------------------------|----------------------------|--------------------------------------|
| 1 1/4 - 1     | 24 | 30 | 110 | <b>R-620-616RFCF</b>        | <b>RF20-16CFX</b>          | 0.7                                  |
| 1 1/2 - 1     | 24 | 39 | 115 | <b>R-624-616RFCF</b>        | <b>RF24-16CFX</b>          | 0.9                                  |
| 1 1/2 - 1 1/4 | 30 | 39 | 130 | <b>R-624-620RFCF</b>        | <b>RF24-20CFX</b>          | 1.1                                  |
| 2 - 1 1/4     | 30 | 49 | 130 | <b>R-632-620RFCF</b>        | <b>RF32-20CFX</b>          | 1.3                                  |
| 2 - 1 1/2     | 39 | 49 | 130 | <b>R-632-624RFCF</b>        | <b>RF32-24CFX</b>          | 1.4                                  |

Other sizes on request

Please change suffixes according to material/surface required

| Order code suffixes             |                             |               |
|---------------------------------|-----------------------------|---------------|
| Material                        | Suffix surface and material | Example       |
| Steel, zinc plated, Cr(VI)-free | CF                          | R-620-616RFCF |
| Stainless steel                 | SS                          | R-620-616RFSS |



## FB90 – 90° Flange bend

SAE 6000/ISO 6162-2

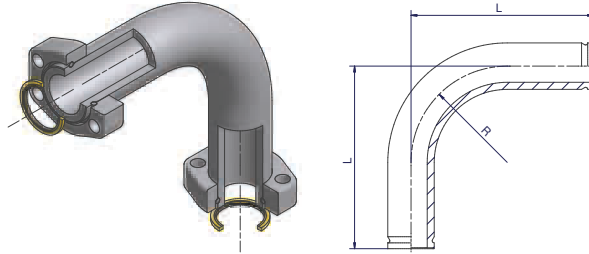

| Size<br>Inch | Tube   | L   | R   | Complete Part<br>Order code | 90° Flange Bend<br>Order code | Weight body<br>(Steel)<br>kg/1 piece |
|--------------|--------|-----|-----|-----------------------------|-------------------------------|--------------------------------------|
| 1            | 39X7.5 | 160 | 98  | <b>R-616FB90S</b>           | FB90-16SX                     | 1.59                                 |
| 1 1/4        | 46X8.0 | 180 | 96  | <b>R-620FB90S</b>           | FB90-20SX                     | 2.35                                 |
| 1 1/2        | 56X8.5 | 220 | 116 | <b>R-624FB90S</b>           | FB90-24SX                     | 3.84                                 |
| 2            | 66X8.5 | 275 | 165 | <b>R-632FB90S</b>           | FB90-32SX                     | 5.72                                 |

Please change suffixes according to material/surface required

| Order code suffixes             |                                |             |            |
|---------------------------------|--------------------------------|-------------|------------|
| Material                        | Suffix surface<br>and material | Example     | Comments   |
| Steel, zinc plated, Cr(VI)-free | S                              | R-620FB90S  |            |
| Stainless steel                 | SS                             | R-620FB90SS | on request |

**FB45 – 45° Flange bend**

SAE 6000/ISO 6162-2

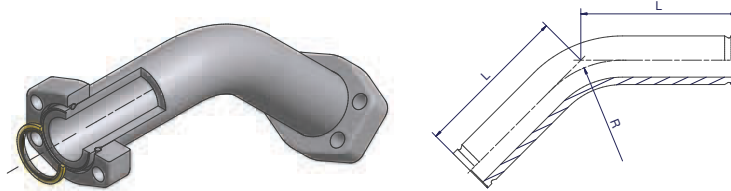

| Size<br>Inch | Tube   | L   | R   | Complete Part<br>Order code | 45° Flange Bend<br>Order code | Weight body<br>(Steel)<br>kg/1 piece |
|--------------|--------|-----|-----|-----------------------------|-------------------------------|--------------------------------------|
| 1            | 39X7.5 | 140 | 80  | <b>R-616FB45S</b>           | FB45-16SX                     | 1.58                                 |
| 1 1/4        | 46X8.0 | 150 | 96  | <b>R-620FB45S</b>           | FB45-20SX                     | 2.18                                 |
| 1 1/2        | 56X8.5 | 180 | 116 | <b>R-624FB45S</b>           | FB45-24SX                     | 3.49                                 |
| 2            | 66X8.5 | 220 | 165 | <b>R-632FB45S</b>           | FB45-32SX                     | 5.16                                 |

Available on request

Please change suffixes according to material/surface required

| Order code suffixes             |                             |             |            |
|---------------------------------|-----------------------------|-------------|------------|
| Material                        | Suffix surface and material | Example     | Comments   |
| Steel, zinc plated, Cr(VI)-free | S                           | R-620FB45S  |            |
| Stainless steel                 | SS                          | R-620FB45SS | on request |



## FB90 – 90° Flange bend

SAE 6000/ISO 6162-2

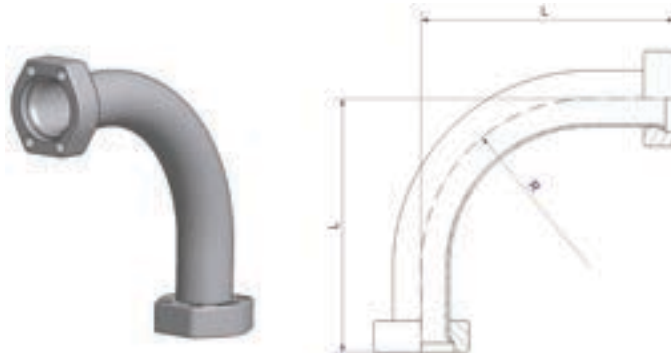

| Size<br>Inch | Tube | Complete Part<br>Order code | L   | R   | W.P. in bar according to EDIN 2413 (bended pipes)                |   |
|--------------|------|-----------------------------|-----|-----|--|---|
|              |      |                             |     |     | Tube E355N/St52.4 NBK -<br>Cr(VI) plated or phosphated and oiled | Seamless Colddrawn Stainless Steel<br>Tube ASTM A269/A213 - AISI 316L |
| 1 1/2        | 50X5 | <b>F37-624FB90</b>          | 220 | 150 | 263  | 218   |
| 2            | 60X5 | <b>F37-632FB90</b>          | 275 | 180 | 222  | 184   |

Other sizes on request

Please change suffixes according to material/surface required

| Order code suffixes             |                                |               |
|---------------------------------|--------------------------------|---------------|
| Material                        | Suffix surface<br>and material | Example       |
| Steel, zinc plated, Cr(VI)-free | CF                             | F37-624FB90CF |
| Stainless steel                 | SS                             | F37-624FB90SS |

**FB45 – 45° Flange bend**

SAE 6000/ISO 6162-2

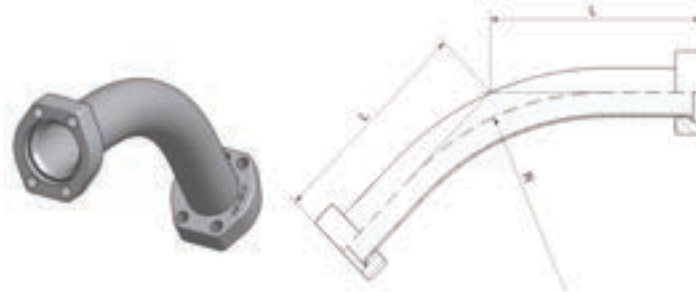

| Size<br>Inch | Tube | Complete Part<br>Order code | L   | R   | W.P. in bar according to EDIN 2413 (bended pipes)                |   |
|--------------|------|-----------------------------|-----|-----|--|---|
|              |      |                             |     |     | Tube E355N/St52.4 NBK -<br>Cr(VI) plated or phosphated and oiled | Seamless Colddrawn Stainless Steel<br>Tube ASTM A269/A213 - AISI 316L |
| 1 1/2        | 50X5 | <b>F37-624FB45</b>          | 180 | 150 | 263  | 218   |
| 2            | 60X5 | <b>F37-632FB45</b>          | 220 | 180 | 222  | 184   |

Other sizes on request

Please change suffixes according to material/surface required

| Order code suffixes             |                                |               |
|---------------------------------|--------------------------------|---------------|
| Material                        | Suffix surface<br>and material | Example       |
| Steel, zinc plated, Cr(VI)-free | CF                             | F37-624FB45CF |
| Stainless steel                 | SS                             | F37-624FB45SS |



## LF – Elbow flange

SAE 6000/ISO 6162-2

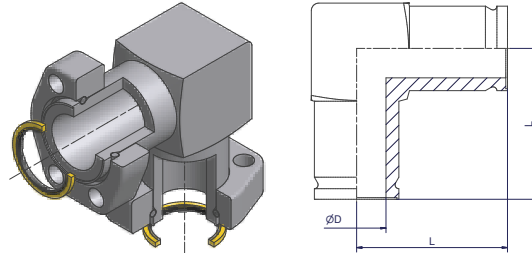

| Size<br>Inch | D  | L   | Complete Part<br>Order code | Elbow Flange<br>body<br>Order code | Weight body (Steel)<br>kg/1 piece |
|--------------|----|-----|-----------------------------|------------------------------------|-----------------------------------|
| 1/2          | 14 | 70  | <b>R-608LFCF</b>            | <b>LF08CFX</b>                     | 0.50                              |
| 3/4          | 20 | 80  | <b>R-612LFCF</b>            | <b>LF12CFX</b>                     | 1.07                              |
| 1            | 24 | 85  | <b>R-616LFCF</b>            | <b>LF16CFX</b>                     | 1.32                              |
| 1 1/4        | 30 | 90  | <b>R-620LFCF</b>            | <b>LF20CFX</b>                     | 1.72                              |
| 1 1/2        | 39 | 100 | <b>R-624LFCF</b>            | <b>LF24CFX</b>                     | 2.60                              |
| 2            | 49 | 110 | <b>R-632LFCF</b>            | <b>LF32CFX</b>                     | 4.02                              |

Please change suffixes according to material/surface required

| Order code suffixes             |                                |           |
|---------------------------------|--------------------------------|-----------|
| Material                        | Suffix surface<br>and material | Example   |
| Steel, zinc plated, Cr(VI)-free | CF                             | R-620LFCF |
| Stainless steel                 | SS                             | R-620LFSS |

**TF – TEE flange**

SAE 6000/ISO 6162-2

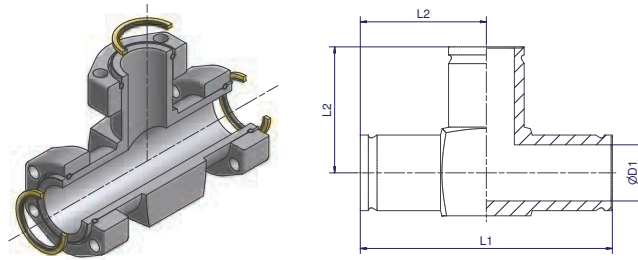

| Size<br>Inch | D1 | L1  | L2  | Complete Part<br>Order code | Tee Flange<br>body<br>Order code | Weight body<br>(Steel)<br>kg/1 piece |
|--------------|----|-----|-----|-----------------------------|----------------------------------|--------------------------------------|
| 1/2          | 14 | 120 | 60  | <b>R-608TFCF</b>            | <b>TF08CFX</b>                   | 0.75                                 |
| 3/4          | 20 | 130 | 65  | <b>R-612TFCF</b>            | <b>TF12CFX</b>                   | 3.20                                 |
| 1            | 24 | 140 | 70  | <b>R-616TFCF</b>            | <b>TF16CFX</b>                   | 2.00                                 |
| 1 1/4        | 30 | 180 | 90  | <b>R-620TFCF</b>            | <b>TF20CFX</b>                   | 2.03                                 |
| 1 1/2        | 39 | 200 | 100 | <b>R-624TFCF</b>            | <b>TF24CFX</b>                   | 3.13                                 |
| 2            | 49 | 220 | 110 | <b>R-632TFCF</b>            | <b>TF32CFX</b>                   | 4.53                                 |

Please change suffixes according to material/surface required

| Order code suffixes             |                                |           |
|---------------------------------|--------------------------------|-----------|
| Material                        | Suffix surface<br>and material | Example   |
| Steel, zinc plated, Cr(VI)-free | CF                             | R-620TFCF |
| Stainless steel                 | SS                             | R-620TFSS |





## LB – Flange L-block

SAE 6000/ISO 6162-2

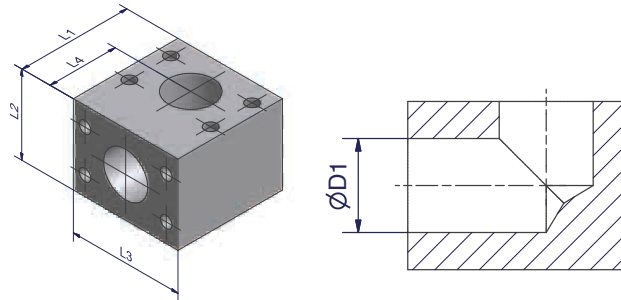

| Size<br>Inch | D1 | L1  | L2 | L3  | L4 | Weight (Steel)<br>kg/1 piece | Order code      |
|--------------|----|-----|----|-----|----|------------------------------|-----------------|
| 1            | 25 | 80  | 65 | 80  | 54 | 2.8                          | <b>LB616CFX</b> |
| 1 1/4        | 30 | 86  | 64 | 90  | 57 | 3.2                          | <b>LB620CFX</b> |
| 1 1/2        | 38 | 90  | 74 | 100 | 66 | 4.6                          | <b>LB624CFX</b> |
| 2            | 50 | 122 | 88 | 132 | 78 | 8.8                          | <b>LB632CFX</b> |

Other sizes on request

Please change suffixes according to material/surface required

| Order code suffixes             |                                   |          |
|---------------------------------|-----------------------------------|----------|
| Material                        | Suffix<br>surface<br>and material | Example  |
| Steel, zinc plated, Cr(VI)-free | CF                                | LB620CFX |
| Stainless steel                 | SS                                | LB620SSX |

**LBR – Flange L-block reducer**

SAE 6000/ISO 6162-2

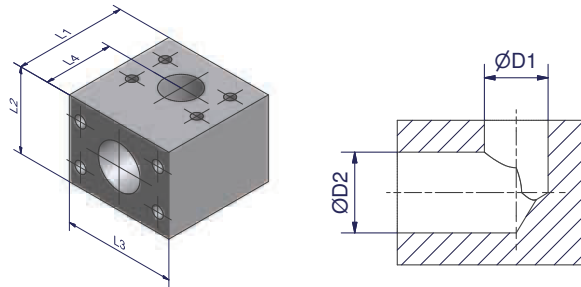

| Size<br>Inch  | D1 | D2 | L1  | L2 | L3  | L4 | Weight (Steel)<br>kg/1 piece | Order code           |
|---------------|----|----|-----|----|-----|----|------------------------------|----------------------|
| 1 1/4 - 1     | 25 | 30 | 86  | 64 | 90  | 57 | 3.3                          | <b>LBR620-616CFX</b> |
| 1 1/2 - 1     | 25 | 38 | 100 | 74 | 100 | 66 | 4.9                          | <b>LBR624-616CFX</b> |
| 1 1/2 - 1 1/4 | 30 | 38 | 100 | 74 | 100 | 66 | 4.8                          | <b>LBR624-620CFX</b> |
| 2 - 1         | 25 | 50 | 122 | 88 | 132 | 78 | 9.4                          | <b>LBR632-616CFX</b> |
| 2 - 1 1/4     | 30 | 50 | 122 | 88 | 132 | 78 | 9.3                          | <b>LBR632-620CFX</b> |
| 2 - 1 1/2     | 38 | 50 | 122 | 88 | 132 | 78 | 9.1                          | <b>LBR632-624CFX</b> |

Other sizes on request

Please change suffixes according to material/surface required

| Order code suffixes             |                                   |               |
|---------------------------------|-----------------------------------|---------------|
| Material                        | Suffix<br>surface<br>and material | Example       |
| Steel, zinc plated, Cr(VI)-free | CF                                | LBR620-616CFX |
| Stainless steel                 | SS                                | LBR620-616SSX |



**TB – Flange T-block**

SAE 6000/ISO 6162-2

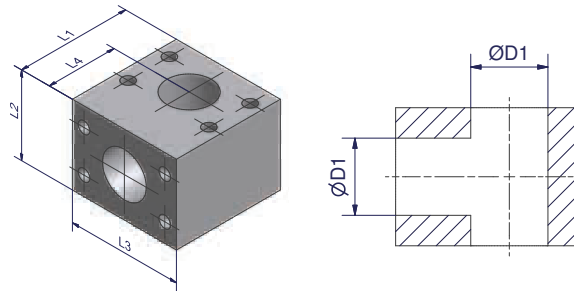

| Size<br>Inch | D1 | L1  | L2 | L3  | L4 | Weight (Steel)<br>kg/1 piece | Order code      |
|--------------|----|-----|----|-----|----|------------------------------|-----------------|
| 3/4          | 19 | 75  | 60 | 75  | 49 | 2.27                         | <b>TB612CFX</b> |
| 1            | 25 | 80  | 65 | 80  | 54 | 1.60                         | <b>TB616CFX</b> |
| 1 1/4        | 30 | 86  | 64 | 90  | 57 | 2.20                         | <b>TB620CFX</b> |
| 1 1/2        | 38 | 100 | 74 | 100 | 66 | 3.10                         | <b>TB624CFX</b> |
| 2            | 50 | 122 | 88 | 132 | 78 | 3.90                         | <b>TB632CFX</b> |

Other sizes and combinations on request

Please change suffixes according to material/surface required

| Order code suffixes             |                                   |          |
|---------------------------------|-----------------------------------|----------|
| Material                        | Suffix<br>surface<br>and material | Example  |
| Steel, zinc plated, Cr(VI)-free | CF                                | TB620CFX |
| Stainless steel                 | SS                                | TB620SSX |

**TBR – Flange T-block reducer**

SAE 6000/ISO 6162-2

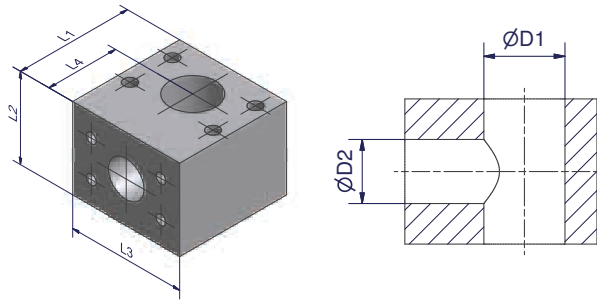

| Size Inch             | D1 | D2 | L1  | L2 | L3  | L4 | Weight (Steel) kg/1 piece | Order code               |
|-----------------------|----|----|-----|----|-----|----|---------------------------|--------------------------|
| 1 1/4 - 1 - 1 1/4     | 30 | 25 | 86  | 64 | 90  | 57 | 3.1                       | <b>TBR620-616-620CFX</b> |
| 1 1/2 - 1 1/4 - 1 1/2 | 38 | 30 | 100 | 74 | 100 | 66 | 4.4                       | <b>TBR624-620-624CFX</b> |
| 1 1/2 - 1 - 1 1/2     | 38 | 25 | 100 | 74 | 100 | 66 | 4.6                       | <b>TBR624-616-624CFX</b> |
| 2 - 1 1/2 - 2         | 50 | 38 | 122 | 88 | 132 | 78 | 8.5                       | <b>TBR632-624-632CFX</b> |
| 2 - 1 1/4 - 2         | 50 | 30 | 122 | 88 | 132 | 78 | 8.8                       | <b>TBR632-620-632CFX</b> |

Other sizes on request

Please change suffixes according to material/surface required

| Order code suffixes             |                             |                   |
|---------------------------------|-----------------------------|-------------------|
| Material                        | Suffix surface and material | Example           |
| Steel, zinc plated, Cr(VI)-free | CF                          | TBR620-616-620CFX |
| Stainless steel                 | SS                          | TBR620-616-620SSX |



## BFV – Blind flange

SAE 6000/ISO 6162-2

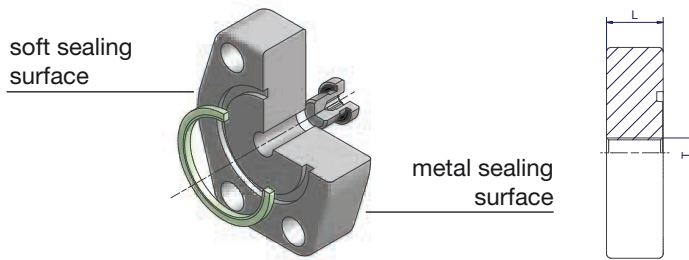

| Size<br>Inch | L  | T1    | Weight<br>(Steel)<br>kg/1 piece | Flange incl.<br>VSTI-ED and F37 Seal<br>Order code |
|--------------|----|-------|---------------------------------|--|
| 1/2          | 20 | G 1/4 | 0.29                            | <b>F37-608BFVCF</b>                                |
| 3/4          | 24 | G 1/4 | 0.57                            | <b>F37-612BFVCF</b>                                |
| 1            | 24 | G 1/4 | 0.60                            | <b>F37-616BFVCF</b>                                |
| 1 1/4        | 22 | G 1/4 | 0.70                            | <b>F37-620BFVCF</b>                                |
| 1 1/2        | 25 | G 1/4 | 1.10                            | <b>F37-624BFVCF</b>                                |
| 2            | 33 | G 1/4 | 2.00                            | <b>F37-632BFVCF</b>                                |

Other sizes on request

Please change suffixes according to material/surface required

| Order code suffixes             |                             |              |
|---------------------------------|-----------------------------|--------------|
| Material                        | Suffix surface and material | Example      |
| Steel, zinc plated, Cr(VI)-free | CF                          | F37-620BFVCF |
| Stainless steel                 | SS                          | F37-620BFVSS |

**BS – Bonded seal**

SAE 6000/ISO 6162-2

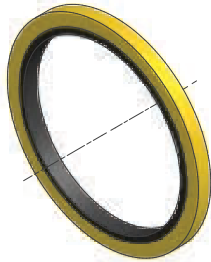

| Size<br>Inch | Steel          | Stainless Steel |
|--------------|----------------|-----------------|
| 1/2          | <b>BS08SNX</b> | <b>BS08SSNX</b> |
| 3/4          | <b>BS12SNX</b> | <b>BS12SSNX</b> |
| 1            | <b>BS16SNX</b> | <b>BS16SSNX</b> |
| 1 1/4        | <b>BS20SNX</b> | <b>BS20SSNX</b> |
| 1 1/2        | <b>BS24SNX</b> | <b>BS24SSNX</b> |
| 2            | <b>BS32SNX</b> | <b>BS32SSNX</b> |

Sealing: NBR  
Other sealing materials like FKM on request

**F37S – F37 Seal**

SAE 6000/ISO 6162-2

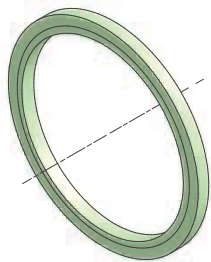

| Size<br>Inch | F37 Seal       |
|--------------|----------------|
| 1/2          | <b>F37S08X</b> |
| 3/4          | <b>F37S12X</b> |
| 1            | <b>F37S16X</b> |
| 1 1/4        | <b>F37S20X</b> |
| 1 1/2        | <b>F37S24X</b> |
| 2            | <b>F37S32X</b> |

Sealing: Polyurethane  
Material properties and applications see page 18



**AO – Adapter bonded seal to F37 seal/O-Ring**

SAE 6000/ISO 6162-2

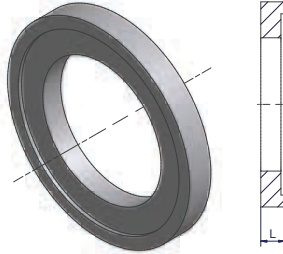

| Size<br>Inch | L | Weight<br>(Steel)<br>kg/1 piece | Adapter*<br>Order code |
|--------------|---|---------------------------------|------------------------|
| 1/2          | 5 | 0.02                            | <b>AO08CFX</b>         |
| 3/4          | 5 | 0.02                            | <b>AO12CFX</b>         |
| 1            | 7 | 0.06                            | <b>AO16CFX</b>         |
| 1 1/4        | 7 | 0.06                            | <b>AO20CFX</b>         |
| 1 1/2        | 7 | 0.08                            | <b>AO24CFX</b>         |
| 2            | 7 | 0.10                            | <b>AO32CFX</b>         |

\*Part excluding seals

Please change suffixes according to material/surface required

| Order code suffixes             |                             |         |
|---------------------------------|-----------------------------|---------|
| Material                        | Suffix surface and material | Example |
| Steel, zinc plated, Cr(VI)-free | CF                          | AO32CFX |
| Stainless steel                 | SS                          | AO32SSX |

**TBT – Tee between bonded seal**

SAE 6000/ISO 6162-2

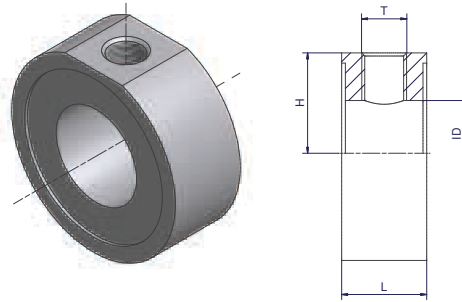

| Size Inch | L  | H    | T     | ID | Bolt ISO 4762 | Weight (Steel) kg/1 piece | Order code*         |
|-----------|----|------|-------|----|---------------|---------------------------|---------------------|
| 1         | 25 | 20.5 | G 1/4 | 25 | ZYLS10X90     | 0.21                      | <b>TBT16-1/4CFX</b> |
| 1 1/4     | 25 | 24.5 | G 1/4 | 27 | ZYLS10X100    | 0.30                      | <b>TBT20-1/4CFX</b> |
| 1 1/4     | 40 | 22.5 | G 1/2 | 24 | ZYLS10X120    | 0.49                      | <b>TBT20-1/2CFX</b> |
| 1 1/2     | 25 | 29.5 | G 1/4 | 31 | ZYLS12X110    | 0.42                      | <b>TBT24-1/4CFX</b> |
| 1 1/2     | 40 | 28.0 | G 1/2 | 30 | ZYLS12X130    | 0.68                      | <b>TBT24-1/2CFX</b> |
| 2         | 25 | 35.0 | G 1/4 | 41 | ZYLS12X110    | 0.51                      | <b>TBT32-1/4CFX</b> |
| 2         | 40 | 34.0 | G 1/2 | 38 | ZYLS12X130    | 0.87                      | <b>TBT32-1/2CFX</b> |

\*Part excluding seals  
For testpoints and diagnostic test equipment see catalogue 4100, Industrial Tube Fittings Europe

Alternative versions on request



**TFVB**

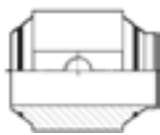

**TTB**

Please change suffixes according to material/surface required

| Order code suffixes             |                             |              |
|---------------------------------|-----------------------------|--------------|
| Material                        | Suffix surface and material | Example      |
| Steel, zinc plated, Cr(VI)-free | CF                          | TBT24-1/4CFX |
| Stainless steel                 | SS                          | TBT24-1/4SSX |





## AP – SAE flange locking plate

SAE 6000/ISO 6162-2

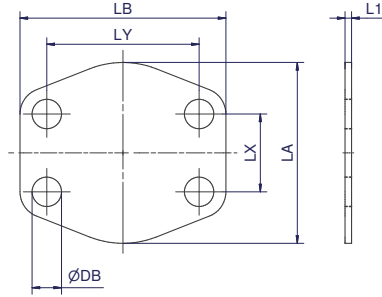

| Nom. flange size |             | L1* | LA  | LB  | LX   | LY    | DB   | Weight body<br>(Steel)<br>kg/1 piece | Order code   |
|------------------|-------------|-----|-----|-----|------|-------|------|--------------------------------------|--------------|
| SAE<br>(In)      | ISO<br>(DN) |     |     |     |      |       |      |                                      |              |
| 1/2              | 13          | 4   | 47  | 57  | 18.2 | 40.5  | 9.0  | 0.02                                 | <b>8AP2</b>  |
| 3/4              | 19          | 4   | 53  | 71  | 23.8 | 50.8  | 11.0 | 0.02                                 | <b>12AP2</b> |
| 1                | 25          | 4   | 66  | 80  | 27.8 | 57.1  | 13.0 | 0.03                                 | <b>16AP2</b> |
| 1 1/4            | 32          | 4   | 77  | 94  | 31.8 | 66.7  | 15.0 | 0.04                                 | <b>20AP2</b> |
| 1 1/2            | 38          | 4   | 89  | 103 | 36.5 | 79.4  | 17.0 | 0.05                                 | <b>24AP2</b> |
| 2                | 51          | 4   | 123 | 135 | 44.5 | 96.8  | 21.0 | 0.06                                 | <b>32AP2</b> |
| 2 1/2            | 64          | 4   | 150 | 166 | 58.7 | 123.8 | 25.0 | 0.08                                 | <b>40AP2</b> |
| 3                | 76          | 4   | 178 | 208 | 71.4 | 125.4 | 32.0 | 0.10                                 | <b>48AP2</b> |

\*L1 x 2 with locking and rubber plate (CFSBR70)  
This flange locking plate is not used under pressure!

Please change suffixes according to material/surface required

| Order code suffixes                              |                             |             |                            |
|--|-----------------------------|-------------|----------------------------|
| Material   | Suffix surface and material | Example     | Description                |
| Steel, zinc plated, Cr(VI)-free                  | CF                          | 8AP2CF      | only locking plate         |
| Stainless steel                                  | SS                          | 8AP2SS      | only locking plate         |
| Steel (zinc plated, Cr(VI)-free), SBR 70 Shore A | CFSBR70                     | 8AP2CFSBR70 | locking incl. rubber plate |

## Bolts and nuts for flange

SAE 6000/ISO 6162-2



### F37 Flare Flange

| Size<br>Inch | Flange      | F37 Seal / Flat Face / Bonded Seal |                       | Nut             |
|--------------|-------------|------------------------------------|-----------------------|-----------------|
|              |             | Bolts<br>Tube to Port              | Bolts<br>Tube to Tube |                 |
| 1/2          | F37-608-CFX | 4 x ZYLS8X35                       | 4 x ZYLS8X65          | 4 x ISO4032-M8  |
| 3/4          | F37-612-CFX | 4 x ZYLS10X45                      | 4 x ZYLS10X75         | 4 x ISO4032-M10 |
| 1            | F37-616-CFX | 4 x ZYLS12X45                      | 4 x ZYLS12X75         | 4 x ISO4032-M12 |
| 1 1/4        | F37-620-CFX | 4 x ZYLS14X55                      | 4 x ZYLS14X90         | 4 x ISO4032-M14 |
| 1 1/2        | F37-624-CFX | 4 x ZYLS16X60                      | 4 x ZYLS16X100        | 4 x ISO4032-M16 |
| 2            | F37-632-CFX | 4 x ZYLS20X70                      | 4 x ZYLS20X120        | 4 x ISO4032-M20 |

### Retaining Ring Flange

| Size<br>Inch | Flange    | Flat Face / Bonded Seal |                       | Nut             |
|--------------|-----------|-------------------------|-----------------------|-----------------|
|              |           | Bolts<br>Tube to Port   | Bolts<br>Tube to Tube |                 |
| 1/2          | R-608-CFX | 4 x ZYLS8X35            | 4 x ZYLS8X60          | 4 x ISO4032-M8  |
| 3/4          | R-612-CFX | 4 x ZYLS10X45           | 4 x ZYLS10X80         | 4 x ISO4032-M10 |
| 1            | R-616-CFX | 4 x ZYLS12X45           | 4 x ZYLS12X80         | 4 x ISO4032-M12 |
| 1 1/4        | R-620-CFX | 4 x ZYLS14X50           | 4 x ZYLS14X90         | 4 x ISO4032-M14 |
| 1 1/2        | R-624-CFX | 4 x ZYLS16X60           | 4 x ZYLS16X110        | 4 x ISO4032-M16 |
| 2            | R-632-CFX | 4 x ZYLS20X70           | 4 x ZYLS20X110        | 4 x ISO4032-M20 |
| 2 1/2        | R-640-CFX | 4 x ZYLS24X90           | 4 x ZYLS24X150        | 4 x ISO4032-M24 |
| 3            | R-648-CFX | 4 x ZYLS30X100          | 4 x ZYLS30X160        | 4 x ISO4032-M30 |

Bolts and nuts must be ordered separately

Latest information about nuts and bolts see [www.parker.com/tfde/servicemanuals/userguides](http://www.parker.com/tfde/servicemanuals/userguides)

Please add the suffixes according to the bolt quality

| Quality | Steel             |                    | 0Stainless Steel |
|---------|-------------------|--------------------|------------------|
|         | 8.8               | 10.9               | A4-80X           |
| Bolt    | ZYLS16X60X        | ZYLS16X60109X      | ZYLS16X60A4-80X  |
| Nut     | ISO-4032-M12-8VZX | ISO-4032-M12-10VZX | ISO-4032-M12-80X |

\* Bolt quality 10.9 recommended.  
Bolt quality 8.8 can affect the pressure capability.



## KH – Ball valve

400 bar female BSPP thread (ISO 1179-1)

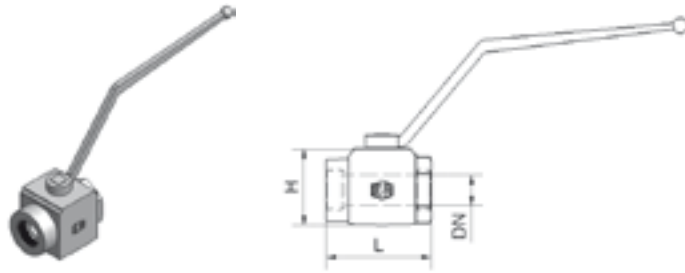

Material Steel

| Size<br>Inch | DN | L   | H   | Order code     | Weight<br>(Steel)<br>kg/1 piece | W.P.<br>bar |
|--------------|----|-----|-----|----------------|---------------------------------|-------------|
| 1 1/4        | 32 | 110 | 80  | <b>KH11/4X</b> | 3                               | 400         |
| 1 1/2        | 40 | 114 | 90  | <b>KH11/2X</b> | 4                               |             |
| 2            | 50 | 129 | 104 | <b>KH2X</b>    | 5                               |             |

Please change suffixes according to material/surface required

| Order code suffixes             |                                   |           |
|---------------------------------|-----------------------------------|-----------|
| Material                        | Suffix<br>surface<br>and material | Example   |
| Steel, zinc plated, Cr(VI)-free | CF                                | KH11/4CFX |
| Steel                           |                                   | KH11/4X   |
| Stainless steel                 | 71                                | KH11/471X |

|              | Materials      |                 |
|--------------|----------------|-----------------|
| Body         | Steel          | Stainless Steel |
| Ball         | Steel          | Stainless Steel |
| Stem         | Steel          | Stainless Steel |
| Ball seats   | POM            | POM             |
| O-Ring       | NBR            | NBR             |
| Tmin / T max | -30°C / 100 °C | -30°C / 100°C   |

**KH – Ball valve drilled and tapped for SAE 6000 and SAE 3000 flanges**

SAE 6000/ISO 6162-2

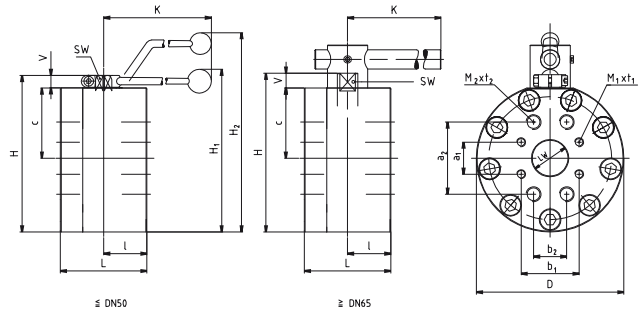

Material Steel

| Order Code       | PN (bar)  | DN | LW | L   | I  | D   | H   | c    | V  | K   | SW | a2   | b2   | M2  | t2 | H1  | H2  | Material Code | Lever | Weight kg |
|------------------|-----------|----|----|-----|----|-----|-----|------|----|-----|----|------|------|-----|----|-----|-----|---------------|-------|-----------|
| <b>KH08-15CF</b> | 210 / 420 | 15 | 15 | 75  | 35 | 88  | 88  | 31.0 | 13 | 160 | 12 | 40.5 | 18.2 | M8  | 18 | -   | 132 | <b>212A</b>   | Al    | 2.96      |
| <b>KH12-20CF</b> | 210 / 420 | 20 | 20 | 80  | 35 | 98  | 100 | 36.5 | 14 | 200 | 14 | 50.8 | 23.8 | M10 | 18 | 103 | -   | <b>212A</b>   | Zn    | 4.20      |
| <b>KH16-25CF</b> | 210 / 420 | 25 | 25 | 88  | 38 | 118 | 113 | 39.5 | 14 | 200 | 14 | 27.8 | 57.2 | M12 | 20 | 116 | -   | <b>212A</b>   | Zn    | 6.00      |
| <b>KH20-32CF</b> | 210 / 420 | 32 | 32 | 100 | 50 | 145 | 158 | 68.0 | 17 | 320 | 17 | 66.7 | 31.8 | M14 | 22 | 167 | -   | <b>212A</b>   | Al    | 11.65     |
| <b>KH24-38CF</b> | 210 / 420 | 40 | 38 | 110 | 55 | 165 | 178 | 78.0 | 17 | 320 | 17 | 79.4 | 36.5 | M16 | 27 | 187 | -   | <b>212A</b>   | Al    | 17.10     |
| <b>KH32-48CF</b> | 210 / 420 | 50 | 48 | 116 | 58 | 198 | 210 | 94.0 | 17 | 320 | 17 | 96.8 | 44.5 | M20 | 28 | 219 | -   | <b>212A</b>   | Al    | 24.60     |

Steel ball valves 1/2" up to 2" with SAE 3000 and SAE 6000 boring pattern

Please change suffixes according to material/surface required

| Order code suffixes             |                             |           |            |
|---------------------------------|-----------------------------|-----------|------------|
| Material                        | Suffix surface and material | Example   | Comments   |
| Steel, zinc plated, Cr(VI)-free | CF                          | KH20-32CF | on request |
| Stainless steel                 | SS                          | KH20-32SS |            |

|              | Material 221A |
|--------------|---------------|
| Body         | Stahl         |
| Ball         | Stahl         |
| Stem         | Stahl         |
| Ball seats   | POM           |
| O-Ring       | NBR           |
| Tmin / T max | -10°C / 100°C |



## KH-R – Ball valve with SAE 6000 Flanges

SAE 6000/ISO 6162-2

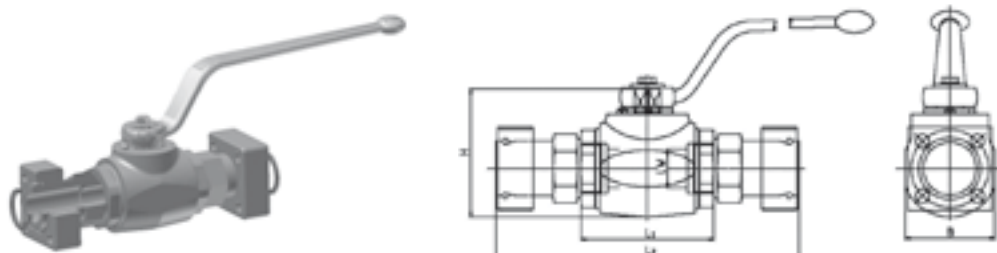

Material Steel

| Size<br>Inch | LW | L1  | L2    | B   | H   | Complete part<br>Order code | Valve body<br>Order code | Weight body<br>(Steel)<br>kg/1 piece | W.P.<br>bar |
|--------------|----|-----|-------|-----|-----|-----------------------------|--------------------------|--------------------------------------|-------------|
| 3/4          | 20 | 95  | 217.0 | 49  | 75  | <b>KH-R-612-20CF</b>        | KH-R-12-20CF             | 2.8                                  | 420         |
| 1            | 25 | 113 | 251.0 | 58  | 83  | <b>KH-R-616-25CF</b>        | KH-R-16-25CF             | 4.2                                  | 315         |
| 1 1/4        | 32 | 111 | 271.0 | 81  | 107 | <b>KH-R-620-32CF</b>        | KH-R-20-32CF             | 6.8                                  | 420         |
| 1 1/2        | 38 | 130 | 316.0 | 100 | 124 | <b>KH-R-624-38CF</b>        | KH-R-24-38CF             | 10.8                                 | 420         |
| 2            | 48 | 140 | 348.0 | 118 | 138 | <b>KH-R-632-48CF</b>        | KH-R-32-48CF             | 16.5                                 | 420         |

Material Stainless Steel

| Size<br>Inch | LW | L1  | L2    | B   | H   | Complete part<br>Order code | Valve body<br>Order code | Weight body<br>(Steel)<br>kg/1 piece | W.P.<br>bar |
|--------------|----|-----|-------|-----|-----|-----------------------------|--------------------------|--------------------------------------|-------------|
| 3/4          | 20 | 95  | 217.0 | 49  | 75  | <b>KH-R-612-20SS</b>        | KH-R-12-20SS             | 2.8                                  | 420         |
| 1            | 25 | 113 | 251.0 | 58  | 83  | <b>KH-R-616-25SS</b>        | KH-R-16-25SS             | 4.2                                  | 315         |
| 1 1/4        | 32 | 111 | 271.0 | 81  | 107 | <b>KH-R-620-32SS</b>        | KH-R-20-32SS             | 9.4                                  | 420         |
| 1 1/2        | 38 | 130 | 316.0 | 100 | 124 | <b>KH-R-624-38SS</b>        | KH-R-24-38SS             | 13.8                                 | 420         |
| 2            | 48 | 140 | 348.0 | 118 | 138 | <b>KH-R-632-48SS</b>        | KH-R-32-48SS             | 18.7                                 | 420         |

Please change suffixes according to material/surface required

| Order code suffixes             |                                   |               |
|---------------------------------|-----------------------------------|---------------|
| Material                        | Suffix<br>surface<br>and material | Example       |
| Steel, zinc plated, Cr(VI)-free | CF                                | KH-R-620-32CF |
| Stainless steel                 | SS                                | KH-R-620-32SS |

|              | Materials      |                 |
|--------------|----------------|-----------------|
| Body         | Steel          | Stainless Steel |
| Ball         | Steel          | Stainless Steel |
| Stem         | Steel          | Stainless Steel |
| Ball seats   | POM            | POM             |
| O-Ring       | NBR            | NBR             |
| Tmin / T max | -20°C / 100 °C | -30°C / 100°C   |

**RHD-R – Non return valves**

SAE 6000/ISO 6162-2

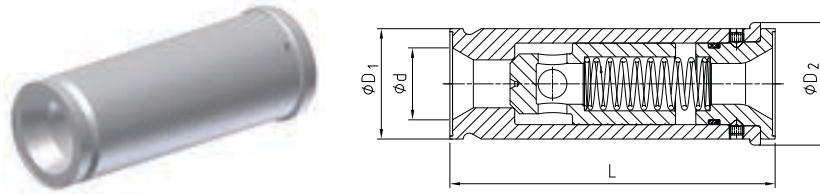

Material Steel

| Size<br>Inch | L     | D1 | D2   | d    | Complete part<br>Order code | Valve body<br>Order code | Weight body<br>(Steel)<br>kg/1 piece | W.P.<br>bar |
|--------------|-------|----|------|------|-----------------------------|--------------------------|--------------------------------------|-------------|
| 1            | 116.6 | 39 | 44.2 | 23.0 | <b>RHD-R-616-0.5BCF</b>     | RHD-R-16-0.5BCF          | 0.78                                 | 420         |
| 1 1/4        | 135.6 | 46 | 51.1 | 30.0 | <b>RHD-R-620-0.5BCF</b>     | RHD-R-20-0.5BCF          | 1.26                                 |             |
| 1 1/2        | 135.6 | 56 | 60.5 | 38.8 | <b>RHD-R-624-0.5BCF</b>     | RHD-R-24-0.5BCF          | 1.61                                 |             |
| 2            | 180.1 | 66 | 70.5 | 49.0 | <b>RHD-R-632-0.5BCF</b>     | RHD-R-32-0.5BCF          | 2.54                                 |             |

Opening pressure 0.5 bar  
Other pressure rates on request

Please change suffixes according to material/surface required

| Order code suffixes                    |                                   |                |
|--|-----------------------------------|----------------|
| Material                               | Suffix<br>surface<br>and material | Example        |
| Steel, zinc plated, Cr(VI)-free        | CF                                | RHD-R-620-32CF |
| Stainless steel<br>(inner parts steel) | SS                                | RHD-R-620-32SS |

|              | Materials      |
|--------------|----------------|
| Body         | Steel          |
| O-Ring       | NBR            |
| Tmin / T max | -10°C / 100 °C |



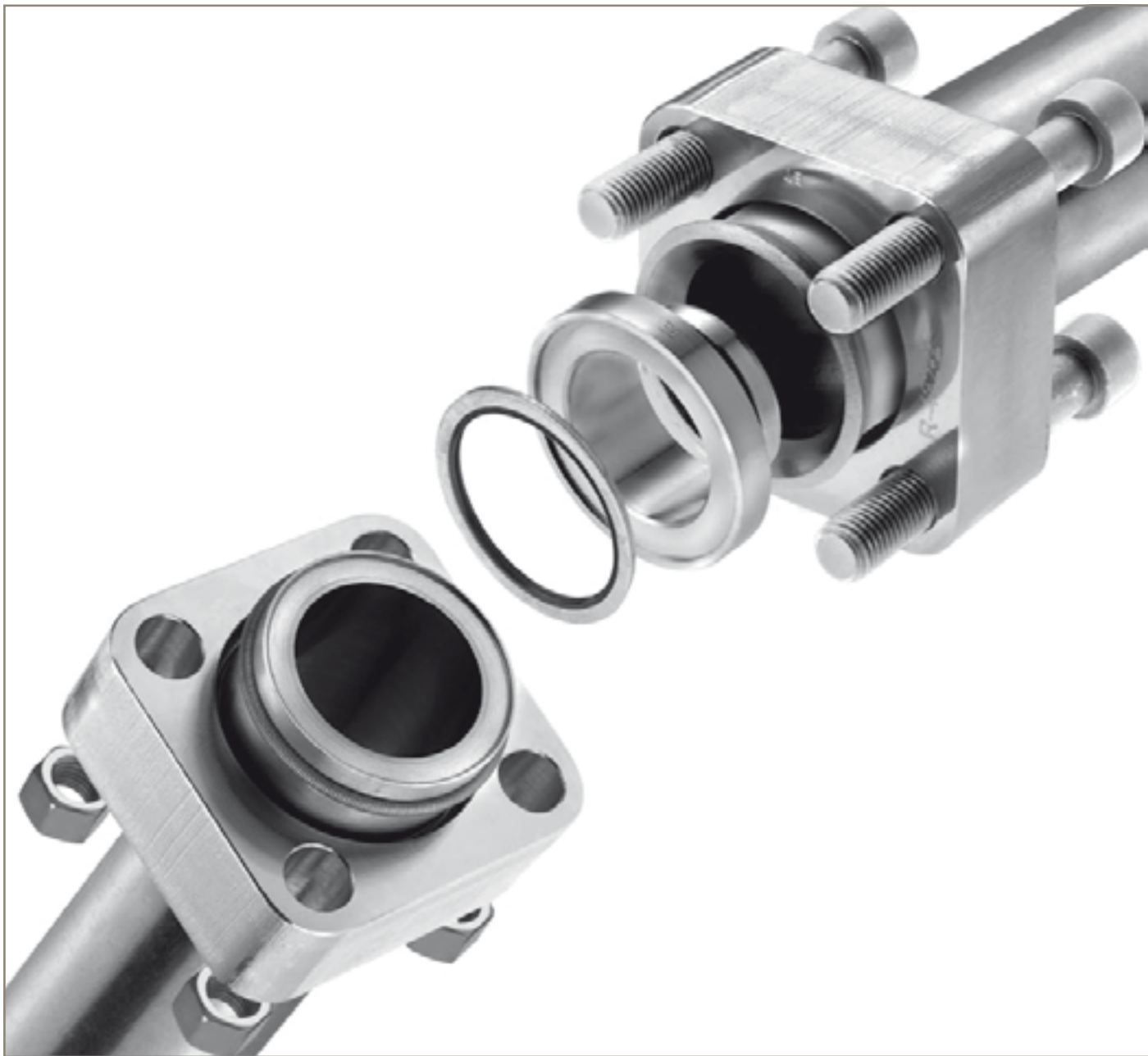

## **ISO 6164 System**







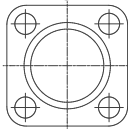
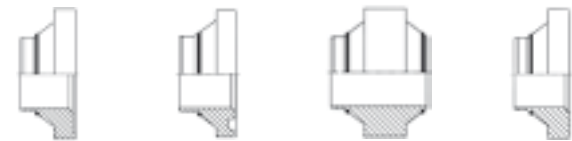

250 – 400 bar

ENGINEERING YOUR SUCCESS.

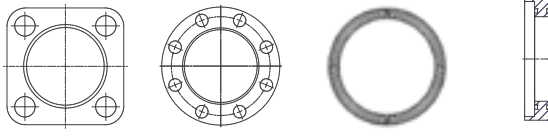

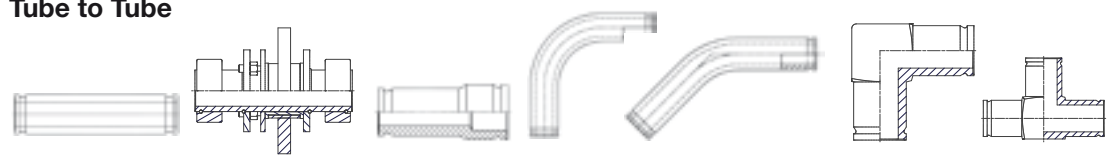
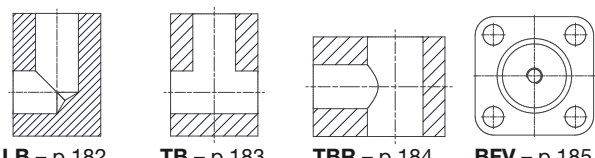

Programme overview ISO 6164 footprint

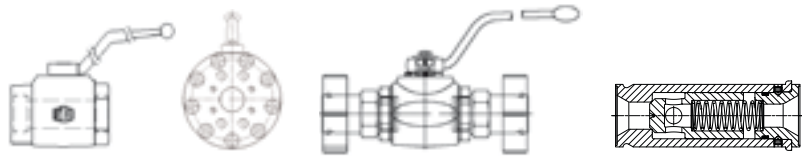
|                                 |  |  |  |  |  |  |  |   |  |  |
|---------------------------------|--|--|--|--|--|--|--|---|--|--|
| Parflange® F37 connection parts | <b>Flanges</b><br><br><b>F37 – p.160/161</b>  |  |  |  |  |  |  |   |  |  |
|                                 | <b>Inserts</b><br><br><b>TFB – p.164    TFV – p.165    TT – p.166    TF – p.167</b>   |  |  |  | <b>Sleeve</b><br><br><b>SL – p.168</b>      |  |  |   |  |  |
| Retaining ring connection parts | <b>Flanges</b><br><br><b>R – p.162    R – p.162    R-Ring – p.169    PSC – p.163</b>  |  |  |  |  | <b>Male / Female</b><br><br><b>MTF-R – p.170    MTF-N – p.171    FTF-R – p.172</b> |  | <b>Hose</b><br><br><b>Hose – p.173</b> |  | <b>Weld</b><br><br><b>WA – p.174</b> |
|                                 | <b>Tube to Tube</b><br><br><b>BF – p.175    VB – p.176    RF – p.177    FB90 – p.178    FB45 – p.179    LF – p.180    TF – p.181</b> |  |  |  |  |  |  |   |  |  |
|                                 | <b>SAE connection parts</b><br><b>Blocks</b><br><br><b>LB – p.182    TB – p.183    TBR – p.184    BFV – p.185</b>                     |  |  |  |  |  |  |   |  |  |
| Seals<br>Adapter<br>Bolts       | <b>Components</b><br><br><b>BS – p.186    F37S – p.186    AO – p.187    TBT – p.188</b>   |  |  |  | <b>Bolts and Nuts</b><br><br><p>p.189</p> |  |  |   |  |  |
|                                 | <b>Ball valves</b><br><br><b>KH – p.190    KH – p.191/192    KH-R – p.193    RHD-R – p.194</b>                                       |  |  |  |  |  |  |   |  |  |

**F37 – Flare flange | ISO 6164 footprint**

ISO 6164

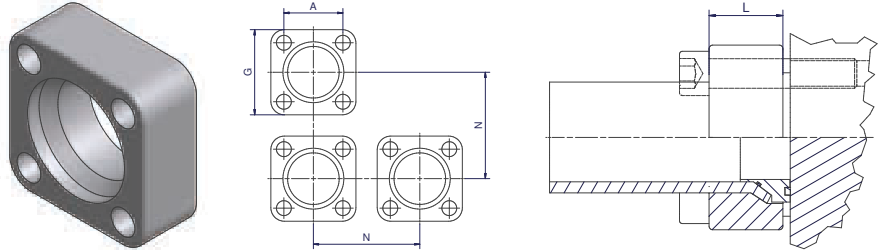

**Parflange F37 flange dimensions**

| Size Inch | Flange Order code     | A     | G   | N   | L  | Weight (Steel) kg/1 piece | W.P. bar |
|-----------|-----------------------|-------|-----|-----|----|---------------------------|----------|
| 2         | <b>F37-432-CFX</b>    | 69.3  | 100 | 105 | 40 | 1.80                      | 400      |
| 2 1/2     | <b>F37-440-CFX</b>    | 83.4  | 120 | 125 | 50 | 3.00                      |          |
| 2 1/2     | <b>F37-44073-CF*</b>  | 83.4  | 120 | 125 | 50 | 3.10                      |          |
| 3         | <b>F37-448-CFX</b>    | 102.5 | 150 | 155 | 52 | 5.40                      |          |
| 3         | <b>F37-448909-CF*</b> | 102.5 | 150 | 155 | 52 | 5.29                      |          |

\* Heavy series (with lockring)

Please change suffixes according to material/surface required

| Order code suffixes             |                             |              |            |
|---------------------------------|-----------------------------|--------------|------------|
| Material                        | Suffix surface and material | Example      | Comments   |
| Steel, zinc plated, Cr(VI)-free | CF                          | F37-432-CFX  |            |
| Stainless steel                 | SS                          | F37-432-SSX  |            |
| Galvanized hot dip zinc         | TZN                         | F37-432-TZNX | on request |



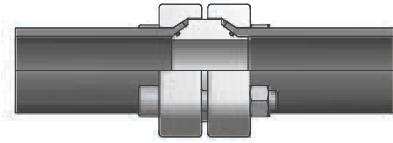

**Part combination flaring ISO 6164**

| Flange Pressure (bar) | Size Inch | Pipe Size | Flange ISO 6164 | Insert*         | F37 Seal | Sleeve         | F37 Seal/ Flat Face/ Bonded Seal |                    | Nut             |
|-----------------------|-----------|-----------|-----------------|-----------------|----------|----------------|----------------------------------|--------------------|-----------------|
|                       |           |           |                 |                 |          |                | Bolts Tube to Port               | Bolts Tube to Tube |                 |
| 400                   | 2         | 50X3.0    | F37-432-CFX     | IN32-50X3.0T... | F37S32X  | SL32-60-50-CFX | 4 x ZYLS16X65                    | 4 x ZYLS16X110     | 4 x ISO4032-M16 |
|                       | 2         | 50X5.0    | F37-432-CFX     | IN32-50X5.0T... | F37S32X  | SL32-60-50-CFX | 4 x ZYLS16X65                    | 4 x ZYLS16X110     | 4 x ISO4032-M16 |
|                       | 2         | 50X6.0    | F37-432-CFX     | IN32-50X6.0T... | F37S32X  | SL32-60-50-CFX | 4 x ZYLS16X65                    | 4 x ZYLS16X110     | 4 x ISO4032-M16 |
|                       | 2         | 60X3.0    | F37-432-CFX     | IN32-60X3.0T... | F37S32X  |                | 4 x ZYLS16X65                    | 4 x ZYLS16X110     | 4 x ISO4032-M16 |
|                       | 2         | 60X5.0    | F37-432-CFX     | IN32-60X5.0T... | F37S32X  |                | 4 x ZYLS16X65                    | 4 x ZYLS16X110     | 4 x ISO4032-M16 |
|                       | 2         | 60X6.0    | F37-432-CFX     | IN32-60X6.0T... | F37S32X  |                | 4 x ZYLS16X65                    | 4 x ZYLS16X110     | 4 x ISO4032-M16 |
|                       | 2 1/2     | 60X3.0    | F37-440-CFX     | IN40-60X3.0T... | F37S40X  | SL40-75-60-CFX | 4 x ZYLS20X80                    | 4 x ZYLS20X140     | 4 x ISO4032-M20 |
|                       | 2 1/2     | 60X5.0    | F37-440-CFX     | IN40-60X5.0T... | F37S40X  | SL40-75-60-CFX | 4 x ZYLS20X80                    | 4 x ZYLS20X140     | 4 x ISO4032-M20 |
|                       | 2 1/2     | 60X6.0    | F37-440-CFX     | IN40-60X6.0T... | F37S40X  | SL40-75-60-CFX | 4 x ZYLS20X80                    | 4 x ZYLS20X140     | 4 x ISO4032-M20 |
|                       | 2 1/2     | 73X7.0    | F37-44073-CF    | IN40-73X7.0T... | F37S40X  |                | 4 x ZYLS20X90                    | 4 x ZYLS20X160     | 4 x ISO4032-M20 |
|                       | 2 1/2     | 75X3.0    | F37-440-CFX     | IN40-75X3.0T... | F37S40X  |                | 4 x ZYLS20X80                    | 4 x ZYLS20X140     | 4 x ISO4032-M20 |
|                       | 2 1/2     | 75X5.0    | F37-440-CFX     | IN40-75X5.0T... | F37S40X  |                | 4 x ZYLS20X80                    | 4 x ZYLS20X140     | 4 x ISO4032-M20 |
|                       | 3         | 75X3.0    | F37-448-CFX     | IN48-75X3.0T... | F37S48X  | SL48-90-75-CFX | 4 x ZYLS24X90                    | 4 x ZYLS24X150     | 4 x ISO4032-M24 |
|                       | 3         | 75X5.0    | F37-448-CFX     | IN48-75X5.0T... | F37S48X  | SL48-90-75-CFX | 4 x ZYLS24X90                    | 4 x ZYLS24X150     | 4 x ISO4032-M24 |
|                       | 3         | 90X3.5    | F37-448-CFX     | IN48-90X3.5T... | F37S48X  |                | 4 x ZYLS24X90                    | 4 x ZYLS24X150     | 4 x ISO4032-M24 |
|                       | 3         | 90X5.0    | F37-448-CFX     | IN48-90X5.0T... | F37S48X  |                | 4 x ZYLS24X90                    | 4 x ZYLS24X150     | 4 x ISO4032-M24 |
|                       | 3         | 90X9.0    | F37-448909-CF   | IN48-90X9.0T... | F37S48X  |                | 4 x ZYLS24X110                   | 4 x ZYLS24X180     | 4 x ISO4032-M24 |

**Select the complete version:**

- \* ...FBCF Bonded Seal version
- ...FVCF F37 Seal version
- ...TCF Tube to Tube version
- ...FCF Flat Face version

Pressure rates related to flanges  
 Other sizes like schedule on request  
 Bolts and nuts for flanges see page 189.

Bolts and nuts are not included in a complete part.

**R – Retaining ring flange | ISO 6164 footprint**

ISO 6164

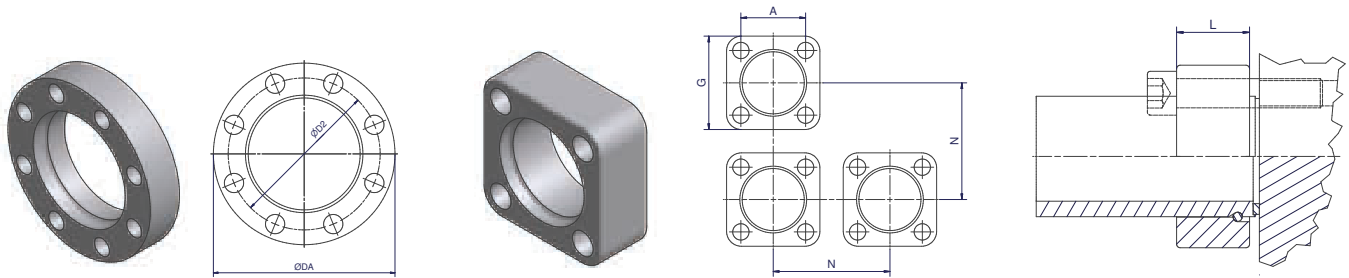

**Retaining ring flange dimensions**

| Size Inch | Flange Order Code    | A     | G   | N   | L  | Weight (Steel) kg/1 piece | W.P. bar |
|-----------|----------------------|-------|-----|-----|----|---------------------------|----------|
| 2         | <b>R-432-CFX</b>     | 69.3  | 100 | 105 | 40 | 1.60                      | 400      |
| 2 1/2     | <b>R-440-CFX</b>     | 83.4  | 120 | 125 | 50 | 2.90                      |          |
| 3         | <b>R-448-CFX</b>     | 102.5 | 150 | 155 | 52 | 5.00                      |          |
| 4         | <b>R-464-CFX</b>     | 123.7 | 180 | 185 | 70 | 9.70                      |          |
|           |                      | D2    | DA  |     |    |                           |          |
| 4 1/2     | <b>R-872-CFX</b>     | 175   | 214 |     | 60 | 8.97                      | 350      |
| 5         | <b>R-880-CFX</b>     | 205   | 245 |     | 70 | 13.44                     | 350      |
| 6         | <b>R-896-CFX</b>     | 245   | 300 |     | 80 | 21.22                     | 350      |
| 8         | <b>R-8128-CFX</b>    | 315   | 385 |     | 92 | 39.27                     | 250      |
| 10        | <b>R-8160273-CFX</b> | 375   | 450 |     | 90 | 59.31                     | 250      |

Please change suffixes according to material/surface required

| Order code suffixes             |                             |            |
|---------------------------------|-----------------------------|------------|
| Material                        | Suffix surface and material | Example    |
| Steel, zinc plated, Cr(VI)-free | CF                          | R-432-CFX  |
| Stainless steel                 | SS                          | R-432-SSX  |
| Galvanized hot dip zinc         | TZN                         | R-432-TZNX |

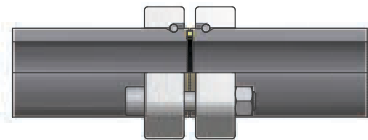

**Part combination Bonded seal ISO 6164 connection**

| Flange pressure (bar) | Size Inch | Pipe Size | Flange    | Retaining Ring | Bonded Seal | Bolts Tube to Port | Bolts Tube to Tube | Nut             |
|-----------------------|-----------|-----------|-----------|----------------|-------------|--------------------|--------------------|-----------------|
| <b>400</b>            | 2         | 66X8,5    | R-432-CFX | R32X           | BS32SNX     | 4 x ZYLS16X65      | 4 x ZYLS16X110     | 4 x ISO4032-M16 |
|                       | 2 1/2     | 80X10     | R-440-CFX | R40X           | BS40SNX     | 4 x ZYLS20X80      | 4 x ZYLS20X140     | 4 x ISO4032-M20 |
|                       | 3         | 97X12     | R-448-CFX | R48X           | BS48SNX     | 4 x ZYLS24X90      | 4 x ZYLS24X150     | 4 x ISO4032-M24 |
|                       | 4         | 115X15    | R-464-CFX | R64X           | BS64SNX     | 4 x ZYLS30X120     | 4 x ZYLS30X190     | 4 x ISO4032-M30 |
| <b>350</b>            | 4 1/2     | 130X15    | R-872-CFX | R72X           | BS72SNX     | 8 x ZYLS20X90      | 8 x ZYLS20X160     | 8 x ISO4032-M20 |
|                       | 5         | 150X15    | R-880-CFX | R80X           | BS80SNX     | 8 x ZYLS24X110     | 8 x ZYLS24X190     | 8 x ISO4032-M24 |



**PSC – Pipe seal carrier | ISO 6164 footprint**

ISO 6164

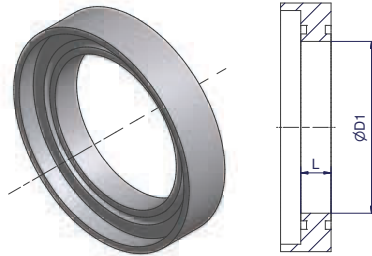

| Size Inch | Pipe size | L    | D1  | Seal carrier       | Flange pressure (bar) |
|-----------|-----------|------|-----|--------------------|-----------------------|
| 2         | 66X8.5    | 10,0 | 49  | PSC32-66X8.5VCF    | 400                   |
| 2 1/2     | 80X10     | 15.0 | 60  | PSC40-80X10VCF     | 400                   |
| 3         | 97X12     | 15.0 | 73  | PSC48-97X12VCF     | 400                   |
| 4         | 115X15    | 15.0 | 85  | PSC64-115X15VCF    | 400                   |
| 4 1/2     | 130X15    | 25.5 | 100 | PSC72-130X15VCF    | 350                   |
| 5         | 150X15    | 38.0 | 120 | PSC80-150X15VCF    | 350                   |
| 6         | 190X20    | 40.0 | 150 | PSC96-190X20VCF    | 350                   |
| 8         | 250X25    | 40.0 | 200 | PSC128-250X25VCF   | 250                   |
| 10        | 273X25.4  | 40.0 | 222 | PSC160-273X25.4VCF | 250                   |

Other sizes on request  
 Steel PSC incl. seals  
 Stainless steel PSC without seals

Please change suffixes according to material/surface required

| Order code suffixes             |                             |                 |
|---------------------------------|-----------------------------|-----------------|
| Material                        | Suffix surface and material | Example         |
| Steel, zinc plated, Cr(VI)-free | CF                          | PSC40-80X10VCF  |
| Stainless steel                 | SS                          | PSC40-80X10VSSX |

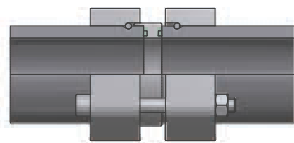

**Part combination Pipe seal carrier ISO 6164 connection**

| Flange pressure (bar) | Size Inch | Pipe Size | Flange        | Retaining Ring | Pipe seal carrier  | O-Ring            | Bolts Tube to Port | Bolts Tube to Tube | Nut         |
|-----------------------|-----------|-----------|---------------|----------------|--------------------|-------------------|--------------------|--------------------|-------------|
| 400                   | 2         | 66X8,5    | R-432-CFX     | R32X           | PSC32-66X8.5VCF    | 2 x OR55.25X2.62  | 4 x ZYLS16X75      | 4 x ZYLS16X110     | ISO4032-M16 |
|                       | 2 1/2     | 80X10     | R-440-CFX     | R40X           | PSC40-80X10VCF     | 2 x OR66.27X3.53  | 4 x ZYLS20X100     | 4 x ZYLS20X140     | ISO4032-M20 |
|                       | 3         | 97X12     | R-448-CFX     | R48X           | PSC48-97X12VCF     | 2 x OR78.97X3.53  | 4 x ZYLS24X120     | 4 x ZYLS24X150     | ISO4032-M24 |
|                       | 4         | 115X15    | R-464-CFX     | R64X           | PSC64-115X15VCF    | 2 x OR94.84X3.53  | 4 x ZYLS30X140     | 4 x ZYLS30X190     | ISO4032-M30 |
| 350                   | 4 1/2     | 130X15    | R-872-CFX     | R72X           | PSC72-130X15VCF    | 2 x OR107.54X3.53 | 8 x ZYLS20X120     | 8 x ZYLS20X190     | ISO4032-M20 |
|                       | 5         | 150X15    | R-880-CFX     | R80X           | PSC80-150X15VCF    | 2 x OR129.77X3.53 | 8 x ZYLS24X130     | 8 x ZYLS24X210     | ISO4032-M24 |
|                       | 6         | 190X20    | R-896-CFX     | R96X           | PSC96-190X20VCF    | 2 x OR158.12X5.33 | 8 x ZYLS30X160     | 8 x ZYLS30X220     | ISO4032-M30 |
| 250                   | 8         | 250X25    | R-8128-CFX    | R128X          | PSC128-250X25VCF   | 2 x OR215.27X5.33 | 8 x ZYLS36X180     | 8 x ZYLS36X250     | ISO4032-M36 |
|                       | 10        | 273X25,4  | R-8160273-CFX | R160X          | PSC160-273X25.4VCF | 2 x OR234.34X5.33 | 12 x ZYLS36X180    | 12 x ZYLS36X250    | ISO4032-M36 |

Other sizes on request

## TFB – Flare flange connection

Tube to port connection, bonded seal

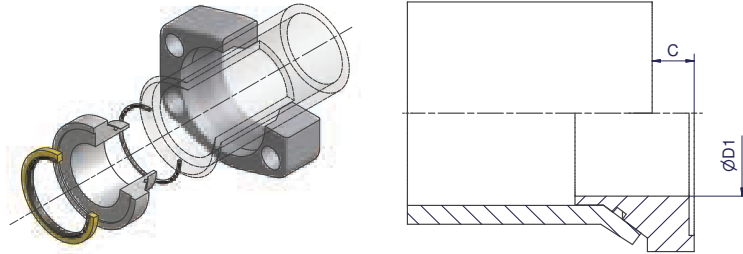

| Size  |        | Flange* incl. Insert + Bonded Seal + O-Ring<br>Order code | D1 | C  | Insert incl.<br>Bonded Seal + O-Ring<br>Order code | Bonded Seal<br>Order code | O-Ring<br>Order code | Weight<br>(Steel)<br>kg/1 piece |
|-------|--------|---|----|----|--|---------------------------|----------------------|---------------------------------|
| Inch  | Tube   |   |    |    |  |                           |                      |                                 |
| 2     | 50X3.0 | <b>F37-432-50X3.0TFBCF</b>                                | 42 | 11 | IN32-50X3.0TFBCF                                   | BS32SNX                   | OR44.17X1.78X        | 2.02                            |
| 2     | 50X5.0 | <b>F37-432-50X5.0TFBCF</b>                                | 38 | 10 | IN32-50X5.0TFBCF                                   | BS32SNX                   | OR41X1.78X           | 2.04                            |
| 2     | 50X6.0 | <b>F37-432-50X6.0TFBCF</b>                                | 35 | 10 | IN32-50X6.0TFBCF                                   | BS32SNX                   | OR41X1.78X           | 2.07                            |
| 2     | 60X3.0 | <b>F37-432-60X3.0TFBCF</b>                                | 46 | 12 | IN32-60X3.0TFBCF                                   | BS32SNX                   | OR53.7X1.78X         | 2.07                            |
| 2     | 60X5.0 | <b>F37-432-60X5.0TFBCF</b>                                | 46 | 11 | IN32-60X5.0TFBCF                                   | BS32SNX                   | OR50.52X1.78X        | 2.04                            |
| 2     | 60X6.0 | <b>F37-432-60X6.0TFBCF</b>                                | 46 | 11 | IN32-60X6.0TFBCF                                   | BS32SNX                   | OR47.37X1.78X        | 2.03                            |
| 2 1/2 | 60X3.0 | <b>F37-440-60X3.0TFBCF</b>                                | 50 | 12 | IN40-60X3.0TFBCF                                   | BS40SNX                   | OR53.7X1.78X         | 3.35                            |
| 2 1/2 | 60X5.0 | <b>F37-440-60X5.0TFBCF</b>                                | 46 | 11 | IN40-60X5.0TFBCF                                   | BS40SNX                   | OR50.52X1.78X        | 3.36                            |
| 2 1/2 | 60X6.0 | <b>F37-440-60X6.0TFBCF</b>                                | 46 | 11 | IN40-60X6.0TFBCF                                   | BS40SNX                   | OR47.37X1.78X        | 3.34                            |
| 2 1/2 | 73X7.0 | <b>F37-440-73X7.0TFBCF</b>                                | 56 | 13 | IN40-73X7.0TFBCF                                   | BS40SNX                   | OR63.22X1.78X        | 3.33                            |
| 2 1/2 | 75X3.0 | <b>F37-440-75X3.0TFBCF</b>                                | 60 | 10 | IN40-75X3.0TFBCF                                   | BS40SNX                   | OR69.57X1.78X        | 3.30                            |
| 2 1/2 | 75X5.0 | <b>F37-440-75X5.0TFBCF</b>                                | 60 | 10 | IN40-75X5.0TFBCF                                   | BS40SNX                   | OR63.22X1.78X        | 3.32                            |
| 3     | 75X3.0 | <b>F37-448-75X3.0TFBCF</b>                                | 66 | 10 | IN48-75X3.0TFBCF                                   | BS48SNX                   | OR69.57X1.78X        | 5.83                            |
| 3     | 75X5.0 | <b>F37-448-75X5.0TFBCF</b>                                | 62 | 10 | IN48-75X5.0TFBCF                                   | BS48SNX                   | OR63.22X1.78X        | 5.99                            |
| 3     | 90X3.5 | <b>F37-448-90X3.5TFBCF</b>                                | 72 | 15 | IN48-90X3.5TFBCF                                   | BS48SNX                   | OR82.27X1.78X        | 6.00                            |
| 3     | 90X5.0 | <b>F37-448-90X5.0TFBCF</b>                                | 72 | 14 | IN48-90X5.0TFBCF                                   | BS48SNX                   | OR79X1.78X           | 5.96                            |
| 3     | 90X9.0 | <b>F37-448-90X9.0TFBCF</b>                                | 69 | 17 | IN48-90X9.0TFBCF                                   | BS48SNX                   | OR72.75X1.78X        | 5.91                            |

Other sizes on request. \*Incl. adapter sleeve or jump size flange if necessary.

Please change suffixes according to material/surface required

| Order code suffixes             |                             |                  |          |
|---------------------------------|-----------------------------|------------------|----------|
| Material                        | Suffix surface and material | Example          | Comments |
| Steel, zinc plated, Cr(VI)-free | CF                          | IN24-50X5.0TFBCF |          |
| Stainless steel                 | SS                          | IN24-50X5.0TFBSS |          |



## TFV – Flare flange connection

Tube to port connection, F37 seal

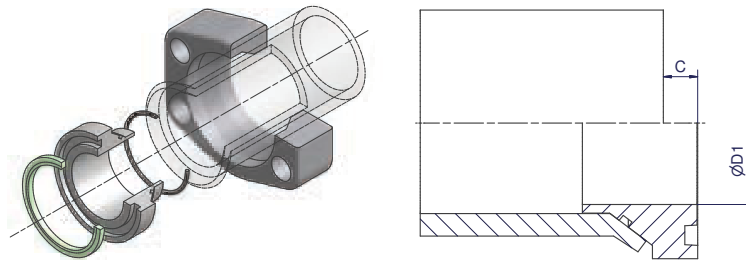

| Size  |        | Flange* incl. Insert + F37 Seal + O-Ring<br>Order code | D1 | C  | Insert incl.<br>F37 Seal + O-Ring<br>Order code | F37 Seal<br>Order code | O-Ring<br>Order code | Weight<br>(Steel)<br>kg/1 piece |
|-------|--------|--|----|----|---|------------------------|----------------------|---------------------------------|
| Inch  | Tube   |  |    |    |   |                        |                      |                                 |
| 2     | 50X3.0 | <b>F37-432-50X3.0TFVCF</b>                             | 42 | 11 | IN32-50X3.0TFVCF                                | F3732X                 | OR44.17X1.78X        | 2.02                            |
| 2     | 50X5.0 | <b>F37-432-50X5.0TFVCF</b>                             | 38 | 10 | IN32-50X5.0TFVCF                                | F3732X                 | OR41X1.78X           | 2.04                            |
| 2     | 50X6.0 | <b>F37-432-50X6.0TFVCF</b>                             | 35 | 10 | IN32-50X6.0TFVCF                                | F3732X                 | OR41X1.78X           | 2.07                            |
| 2     | 60X3.0 | <b>F37-432-60X3.0TFVCF</b>                             | 46 | 12 | IN32-60X3.0TFVCF                                | F3732X                 | OR53.7X1.78X         | 2.07                            |
| 2     | 60X5.0 | <b>F37-432-60X5.0TFVCF</b>                             | 46 | 11 | IN32-60X5.0TFVCF                                | F3732X                 | OR50.52X1.78X        | 2.04                            |
| 2     | 60X6.0 | <b>F37-432-60X6.0TFVCF</b>                             | 46 | 11 | IN32-60X6.0TFVCF                                | F3732X                 | OR47.37X1.78X        | 2.03                            |
| 2 1/2 | 60X3.0 | <b>F37-440-60X3.0TFVCF</b>                             | 50 | 12 | IN40-60X3.0TFVCF                                | F3740X                 | OR53.7X1.78X         | 3.35                            |
| 2 1/2 | 60X5.0 | <b>F37-440-60X5.0TFVCF</b>                             | 46 | 11 | IN40-60X5.0TFVCF                                | F3740X                 | OR50.52X1.78X        | 3.36                            |
| 2 1/2 | 60X6.0 | <b>F37-440-60X6.0TFVCF</b>                             | 46 | 11 | IN40-60X6.0TFVCF                                | F3740X                 | OR47.37X1.78X        | 3.34                            |
| 2 1/2 | 73X7.0 | <b>F37-440-73X7.0TFVCF</b>                             | 56 | 13 | IN40-73X7.0TFVCF                                | F3740X                 | OR63.22X1.78X        | 3.33                            |
| 2 1/2 | 75X3.0 | <b>F37-440-75X3.0TFVCF</b>                             | 60 | 10 | IN40-75X3.0TFVCF                                | F3740X                 | OR69.57X1.78X        | 3.30                            |
| 2 1/2 | 75X5.0 | <b>F37-440-75X5.0TFVCF</b>                             | 60 | 10 | IN40-75X5.0TFVCF                                | F3740X                 | OR63.22X1.78X        | 3.32                            |
| 3     | 75X3.0 | <b>F37-448-75X3.0TFVCF</b>                             | 66 | 10 | IN48-75X3.0TFVCF                                | F3748X                 | OR69.57X1.78X        | 5.83                            |
| 3     | 75X5.0 | <b>F37-448-75X5.0TFVCF</b>                             | 62 | 10 | IN48-75X5.0TFVCF                                | F3748X                 | OR63.22X1.78X        | 5.99                            |
| 3     | 90X3.5 | <b>F37-448-90X3.5TFVCF</b>                             | 72 | 15 | IN48-90X3.5TFVCF                                | F3748X                 | OR82.27X1.78X        | 6.00                            |
| 3     | 90X5.0 | <b>F37-448-90X5.0TFVCF</b>                             | 72 | 14 | IN48-90X5.0TFVCF                                | F3748X                 | OR79X1.78X           | 5.96                            |
| 3     | 90X9.0 | <b>F37-448-90X9.0TFVCF</b>                             | 69 | 17 | IN48-90X9.0TFVCF                                | F3748X                 | OR72.75X1.78X        | 5.82                            |

Other sizes on request. \*Incl. adapter sleeve or jump size flange if necessary.

Please change suffixes according to material/surface required

| Order code suffixes             |                             |                  |
|---------------------------------|-----------------------------|------------------|
| Material                        | Suffix surface and material | Example          |
| Steel, zinc plated, Cr(VI)-free | CF                          | IN32-50X5.0TFVCF |
| Stainless steel                 | SS                          | IN32-50X5.0TFVSS |

## TT – Flare Flange Connection

Tube to tube connection

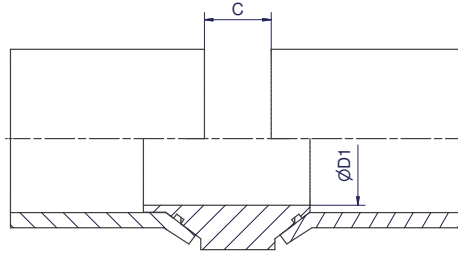
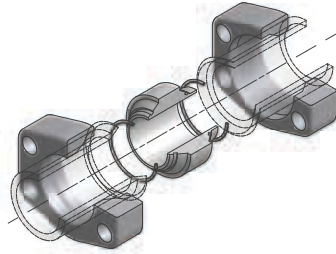

| Size  |        | 2 Flanges* incl. Insert +<br>2 x O-Ring<br>Order code | D1 | C  | Insert incl.<br>2 x O-Ring<br>Order code | O-Ring<br>Order code | Weight<br>(Steel)<br>kg/1 piece |
|-------|--------|---|----|----|--|----------------------|---------------------------------|
| Inch  | Tube   |   |    |    |  |                      |                                 |
| 2     | 50X3.0 | <b>F37-432-50X3.0TTCF</b>                             | 42 | 22 | IN32-50X3.0TTCF                          | OR44.17X1.78X        | 2.22                            |
| 2     | 50X5.0 | <b>F37-432-50X5.0TTCF</b>                             | 38 | 20 | IN32-50X5.0TTCF                          | OR41X1.78X           | 2.33                            |
| 2     | 50X6.0 | <b>F37-432-50X6.0TTCF</b>                             | 35 | 20 | IN32-50X6.0TTCF                          | OR41X1.78X           | 2.38                            |
| 2     | 60X3.0 | <b>F37-432-60X3.0TTCF</b>                             | 46 | 24 | IN32-60X3.0TTCF                          | OR53.7X1.78X         | 2.35                            |
| 2     | 60X5.0 | <b>F37-432-60X5.0TTCF</b>                             | 46 | 22 | IN32-60X5.0TTCF                          | OR50.52X1.78X        | 2.28                            |
| 2     | 60X6.0 | <b>F37-432-60X6.0TTCF</b>                             | 46 | 22 | IN32-60X6.0TTCF                          | OR47.37X1.78X        | 2.27                            |
| 2 1/2 | 60X3.0 | <b>F37-440-60X3.0TTCF</b>                             | 50 | 24 | IN40-60X3.0TTCF                          | OR53.7X1.78X         | 3.35                            |
| 2 1/2 | 60X5.0 | <b>F37-440-60X5.0TTCF</b>                             | 46 | 22 | IN40-60X5.0TTCF                          | OR50.52X1.78X        | 3.36                            |
| 2 1/2 | 60X6.0 | <b>F37-440-60X6.0TTCF</b>                             | 45 | 22 | IN40-60X6.0TTCF                          | OR47.37X1.78X        | 3.34                            |
| 2 1/2 | 73X7.0 | <b>F37-440-73X7.0TTCF</b>                             | 56 | 26 | IN40-73X7.0TTCF                          | OR63.22X1.78X        | 3.33                            |
| 2 1/2 | 75X3.0 | <b>F37-440-75X3.0TTCF</b>                             | 60 | 20 | IN40-75X3.0TTCF                          | OR69.57X1.78X        | 3.30                            |
| 2 1/2 | 75X5.0 | <b>F37-440-75X5.0TTCF</b>                             | 60 | 20 | IN40-75X5.0TTCF                          | OR63.22X1.78X        | 3.32                            |
| 3     | 75X3.0 | <b>F37-448-75X3.0TTCF</b>                             | 66 | 20 | IN48-75X3.0TTCF                          | OR69.57X1.78X        | 5.83                            |
| 3     | 75X5.0 | <b>F37-448-75X5.0TTCF</b>                             | 62 | 20 | IN48-75X5.0TTCF                          | OR63.22X1.78X        | 5.99                            |
| 3     | 90X3.5 | <b>F37-448-90X3.5TTCF</b>                             | 72 | 30 | IN48-90X3.5TTCF                          | OR82.27X1.78X        | 6.00                            |
| 3     | 90X5.0 | <b>F37-448-90X5.0TTCF</b>                             | 72 | 28 | IN48-90X5.0TTCF                          | OR79X1.78X           | 5.96                            |
| 3     | 90X9.0 | <b>F37-448-90X9.0TTCF</b>                             | 69 | 34 | IN48-90X9.0TTCF                          | OR72.75X1.78X        | 5.85                            |

Other sizes on request. \*Incl. adapter sleeve or jump size flange if necessary.

Please change suffixes according to material/surface required

| Order code suffixes             |                             |                 |
|---------------------------------|-----------------------------|-----------------|
| Material                        | Suffix surface and material | Example         |
| Steel, zinc plated, Cr(VI)-free | CF                          | IN32-50X5.0TTCF |
| Stainless steel                 | SS                          | IN32-50X5.0TTSS |





## TF – Flare Flange Connection

Tube to port connection, flat face

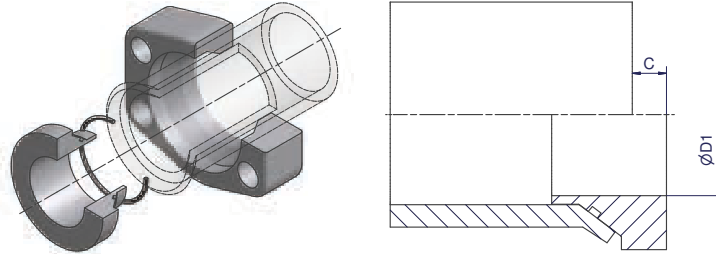

| Size  |        | Flange* incl. Insert +<br>O-Ring<br>Order code | D1 | C  | Insert incl.<br>O-Ring<br>Order code | O-Ring<br>Order code | Weight<br>(Steel)<br>kg/1 piece |
|-------|--------|--|----|----|--------------------------------------|----------------------|---------------------------------|
| Inch  | Tube   |  |    |    |                                      |                      |                                 |
| 2     | 50X3.0 | <b>F37-432-50X3.0TFCF</b>                      | 42 | 11 | IN32-50X3.0TFCF                      | OR44.17X1.78X        | 2.02                            |
| 2     | 50X5.0 | <b>F37-432-50X5.0TFCF</b>                      | 38 | 10 | IN32-50X5.0TFCF                      | OR41X1.78X           | 2.04                            |
| 2     | 50X6.0 | <b>F37-432-50X6.0TFCF</b>                      | 35 | 10 | IN32-50X6.0TFCF                      | OR41X1.78X           | 2.07                            |
| 2     | 60X3.0 | <b>F37-432-60X3.0TFCF</b>                      | 46 | 12 | IN32-60X3.0TFCF                      | OR53.7X1.78X         | 2.07                            |
| 2     | 60X5.0 | <b>F37-432-60X5.0TFCF</b>                      | 46 | 11 | IN32-60X5.0TFCF                      | OR50.52X1.78X        | 2.04                            |
| 2     | 60X6.0 | <b>F37-432-60X6.0TFCF</b>                      | 46 | 11 | IN32-60X6.0TFCF                      | OR47.37X1.78X        | 2.03                            |
| 2 1/2 | 60X3.0 | <b>F37-440-60X3.0TFCF</b>                      | 50 | 12 | IN40-60X3.0TFCF                      | OR53.7X1.78X         | 3.35                            |
| 2 1/2 | 60X5.0 | <b>F37-440-60X5.0TFCF</b>                      | 46 | 11 | IN40-60X5.0TFCF                      | OR50.52X1.78X        | 3.36                            |
| 2 1/2 | 60X6.0 | <b>F37-440-60X6.0TFCF</b>                      | 46 | 11 | IN40-60X6.0TFCF                      | OR47.37X1.78X        | 3.34                            |
| 2 1/2 | 73X7.0 | <b>F37-440-73X7.0TFCF</b>                      | 56 | 13 | IN40-73X7.0TFCF                      | OR63.22X1.78X        | 3.33                            |
| 2 1/2 | 75X3.0 | <b>F37-440-75X3.0TFCF</b>                      | 60 | 10 | IN40-75X3.0TFCF                      | OR69.57X1.78X        | 3.30                            |
| 2 1/2 | 75X5.0 | <b>F37-440-75X5.0TFCF</b>                      | 60 | 10 | IN40-75X5.0TFCF                      | OR63.22X1.78X        | 3.32                            |
| 3     | 75X3.0 | <b>F37-448-75X3.0TFCF</b>                      | 66 | 10 | IN48-75X3.0TFCF                      | OR69.57X1.78X        | 5.83                            |
| 3     | 75X5.0 | <b>F37-448-75X5.0TFCF</b>                      | 62 | 10 | IN48-75X5.0TFCF                      | OR63.22X1.78X        | 5.99                            |
| 3     | 90X3.5 | <b>F37-448-90X3.5TFCF</b>                      | 72 | 15 | IN48-90X3.5TFCF                      | OR82.27X1.78X        | 6.00                            |
| 3     | 90X5.0 | <b>F37-448-90X5.0TFCF</b>                      | 72 | 14 | IN48-90X5.0TFCF                      | OR79X1.78X           | 5.96                            |
| 3     | 90X9.0 | <b>F37-448-90X9.0TFCF</b>                      | 69 | 17 | IN48-90X9.0TFCF                      | OR72.75X1.78X        | 5.82                            |

Other sizes on request. \*Incl. adapter sleeve or jump size flange if necessary.

Please change suffixes according to material/surface required

| Order code suffixes             |                             |                 |
|---------------------------------|-----------------------------|-----------------|
| Material                        | Suffix surface and material | Example         |
| Steel, zinc plated, Cr(VI)-free | CF                          | IN32-50X5.0TFCF |
| Stainless steel                 | SS                          | IN32-50X5.0TFSS |

**SL – Sleeve**

ISO 6164

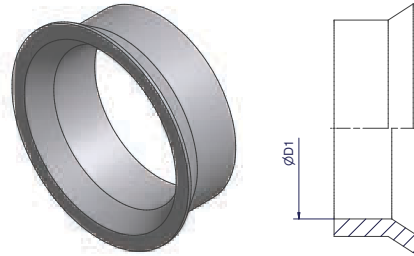

| Size<br>Inch | Tube<br>OD | Order code            | D1    | Weight<br>(Steel)<br>kg/1 piece |
|--------------|------------|-----------------------|-------|---------------------------------|
| 2            | 50         | <b>SL32-60-50-CFX</b> | 50.30 | 0.16                            |
| 2 1/2        | 60         | <b>SL40-75-60-CFX</b> | 60.45 | 0.36                            |
| 3            | 75         | <b>SL48-90-75-CFX</b> | 75.45 | 0.52                            |

Please change suffixes according to material/surface required

| Order code suffixes             |                             |                |
|---------------------------------|-----------------------------|----------------|
| Material                        | Suffix surface and material | Example        |
| Steel, zinc plated, Cr(VI)-free | CF                          | SL24-50-42-CFX |
| Stainless steel                 | SS                          | SL24-50-42-SSX |



**R – Retaining ring**

ISO 6164

| Size<br>Inch | Tube     | D     | S    | Order code   |
|--------------|----------|-------|------|--------------|
| 2            | 66X8.5   | 61.3  | 5.0  | <b>R32X</b>  |
| 2 1/2        | 80X10.0  | 75.3  | 5.0  | <b>R40X</b>  |
| 3            | 97X12.0  | 91.3  | 6.0  | <b>R48X</b>  |
| 4            | 115X15.0 | 107.3 | 8.0  | <b>R64X</b>  |
| 4 1/2        | 130x15.0 | 122.3 | 8.0  | <b>R72X</b>  |
| 5            | 150X15.0 | 142.3 | 8.0  | <b>R80X</b>  |
| 6            | 190x20.0 | 180.3 | 10.0 | <b>R96X</b>  |
| 8            | 250X25.0 | 238.3 | 12.0 | <b>R128X</b> |
| 10           | 273X25.0 | 261.4 | 12.0 | <b>R160X</b> |

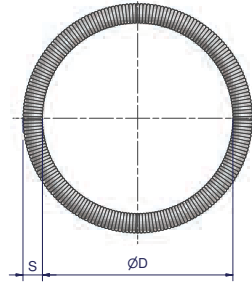

Material: Stainless steel

**MTF-R – Male thread adapter, BSPP**

ISO 6164

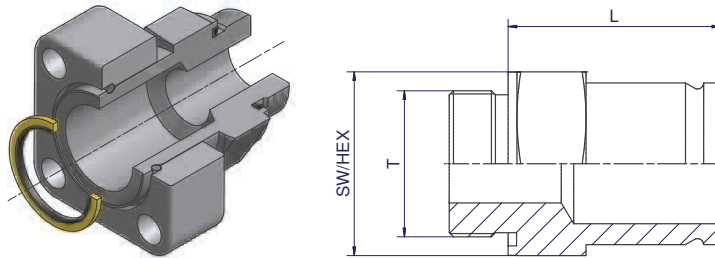

| Size<br>Inch | Tube   | Complete part<br>Order code | Body incl.<br>ED Seal<br>Order code | Weight body<br>(Steel)<br>kg/1 piece | L     | T (BSPP) | SW/<br>HEX |
|--------------|--------|-----------------------------|-------------------------------------|--------------------------------------|-------|----------|------------|
| 2            | 66X8.5 | <b>R-432MTFRCF</b>          | MTF32ROMDCF                         | 1.90                                 | 104.0 | G 2 A    | 75         |

Please change suffixes according to material/surface required

| Order code suffixes             |                             |             |
|---------------------------------|-----------------------------|-------------|
| Material                        | Suffix surface and material | Example     |
| Steel, zinc plated, Cr(VI)-free | CF                          | R-432MTFRCF |
| Stainless steel                 | SS                          | R-432MTFRSS |



## MTF-N – Male thread adapter, NPT

ISO 6164

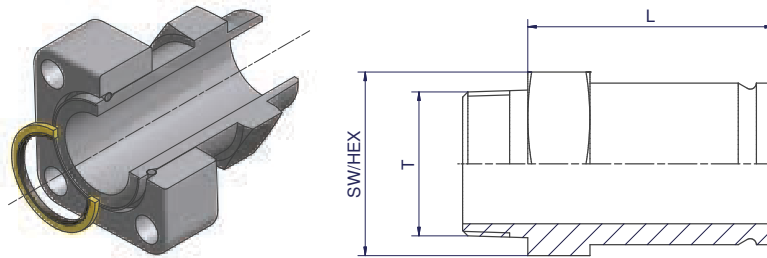

| Size<br>Inch | Tube   | Complete part<br>Order code | Body incl.<br>ED Seal<br>Order code | Weight body<br>(Steel)<br>kg/1 piece | L     | T (NPT) | SW/<br>HEX |
|--------------|--------|-----------------------------|-------------------------------------|--------------------------------------|-------|---------|------------|
| 2            | 66X8.5 | <b>R-432MTFNCF</b>          | MTF32NCFX                           | 1.40                                 | 100.4 | 2-11.5  | 75         |

Please change suffixes according to material/surface required

| Order code suffixes             |                                |             |
|---------------------------------|--------------------------------|-------------|
| Material                        | Suffix surface<br>and material | Example     |
| Steel, zinc plated, Cr(VI)-free | CF                             | R-432MTFNCF |
| Stainless steel                 | SS                             | R-432MTFNSS |

**FTF-R – Female thread adapter, BSPP**

ISO 6164

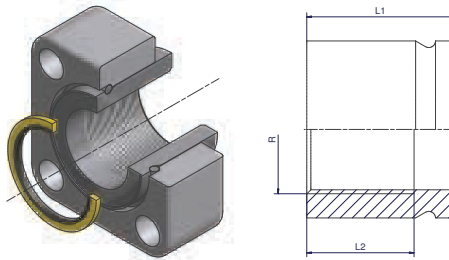

| Size<br>Inch | Tube   | Complete part<br>Order code | Body<br>Order code | Weight body<br>(Steel)<br>kg/1 piece | L1 | L2 | R (BSPP) |
|--------------|--------|-----------------------------|--------------------|--------------------------------------|----|----|----------|
| 2            | 66X8.5 | <b>R-432FTFRCF</b>          | FTF32RCFX          | 0.75                                 | 55 | 40 | G 1 1/2  |
| 2 1/2        | 80X10  | <b>R-440FTFRCF</b>          | FTF40RCFX          | 1.52                                 | 80 | 40 | G 2      |
| 3            | 97X12  | <b>R-448FTFRCF</b>          | FTF48RCFX          | 2.11                                 | 85 | 50 | G 2 1/2  |

Please change suffixes according to material/surface required



| Order code suffixes             |                                |             |
|---------------------------------|--------------------------------|-------------|
| Material                        | Suffix surface<br>and material | Example     |
| Steel, zinc plated, Cr(VI)-free | CF                             | R-432FTFRCF |
| Stainless steel                 | SS                             | R-432FTFRSS |





## Retaining ring hose couplings

ISO 6164

One Piece No-Skive Hose fittings 48 Series for Parker hose types 301SN (2 wire braid) & 421SN (one wire braid)

|            |       |  |  |  |
|------------|-------|---|---|---|
| Connection |       | Order code  | Order code  | Order code  |
| Flange     | Hose  |   |   |   |
| 1 1/4      | 1 1/4 | <b>1X548-20-20</b>  | <b>1X748-20-20</b>  | <b>1X948-20-20</b>  |
| 1 1/2      | 1 1/2 | <b>1X548-24-24</b>  | <b>1X748-24-24</b>  | <b>1X948-24-24</b>  |
| 2          | 2     | <b>1X548-32-32</b>  | <b>1X748-32-32</b>  | <b>1X948-32-32</b>  |

Interlock Hose nipples V6 series for Parker hose types H82 & R42 (6 spiral)

|            |       |  |  |  |
|------------|-------|--|--|--|
| Connection |       | Order code   | Order code   | Order code   |
| Flange     | Hose  |  |  |  |
| 1 1/4      | 1 1/4 | <b>KX5V6-20-20</b>   | <b>KX7V6-20-20</b>   | <b>KX9V6-20-20</b>   |
| 1 1/2      | 1 1/2 | <b>KX5V6-24-24</b>   | <b>KX7V6-24-24</b>   | <b>KX9V6-24-24</b>   |
| 2          | 2     | <b>KX5V6-32-32</b>   | <b>KX7V6-32-32</b>   | <b>KX9V6-32-32</b>   |

Interlock Shells V6 Series for Parker hose types H82 & R42

|            |  |  |
|------------|--|---|
| Connection |  | Order code  |
| Hose       |  |   |
| 1 1/4      |  | <b>100V6-20</b>   |
| 1 1/2      |  | <b>100V6-24</b>   |
| 2          |  | <b>100V6-32</b>   |

**WA – Weld adapter connection**

ISO 6164

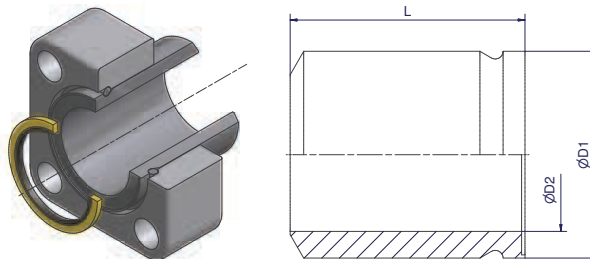

| Size Inch | Tube       | Complete Part Order code   | Retaining Ring | Bonded Seal     | Flange Order code | Weld Adapter Body Order code | Weight (Steel) kg/1 piece | D1  | D2  | L   |
|-----------|------------|----------------------------|----------------|-----------------|-------------------|------------------------------|---------------------------|-----|-----|-----|
| 2         | 48.3X5.6   | <b>R-432WA-48.3X5.6S</b>   | R32X           | BS32SNX         | R-432-CFX         | WA32-48.3X5.6SX              | 2.90                      | 66  | 37  | 90  |
| 2         | 50X9.0     | <b>R-432WA-50X9.0S</b>     | R32X           | BS32SNX         | R-432-CFX         | WA32-50X9.0SX                | 3.11                      | 66  | 32  | 90  |
| 2         | 60X3.0     | <b>R-432WA-60X3.0S</b>     | R32X           | BS32SNX         | R-432-CFX         | WA32-60X3.0SX                | 2.39                      | 66  | 49  | 90  |
| 2         | 60X5.0     | <b>R-432WA-60X5.0S</b>     | R32X           | BS32SNX         | R-432-CFX         | WA32-60X5.0SX                | 2.49                      | 66  | 50  | 90  |
| 2         | 60X6.0     | <b>R-432WA-60X6.0S</b>     | R32X           | BS32SNX         | R-432-CFX         | WA32-60X6.0SX                | 2.60                      | 66  | 48  | 90  |
| 2         | 60X8.0     | <b>R-432WA-60X8.0S</b>     | R32X           | BS32SNX         | R-432-CFX         | WA32-60X8.0SX                | 2.78                      | 66  | 44  | 90  |
| 2         | 60X10.0    | <b>R-432WA-60X10.0S</b>    | R32X           | BS32SNX         | R-432-CFX         | WA32-60X10.0SX               | 2.96                      | 66  | 40  | 90  |
| 2         | 60.3X2.8   | <b>R-432WA-60.3X2.8S</b>   | R32X           | BS32SNX         | R-432-CFX         | WA32-60.3X2.8SX              | 2.37                      | 66  | 49  | 90  |
| 2         | 60.3X3.9   | <b>R-432WA-60.3X3.9S</b>   | R32X           | BS32SNX         | R-432-CFX         | WA32-60.3X3.9SX              | 2.45                      | 66  | 49  | 90  |
| 2         | 60.3X5.5   | <b>R-432WA-60.3X5.5S</b>   | R32X           | BS32SNX         | R-432-CFX         | WA32-60.3X5.5SX              | 2.54                      | 66  | 49  | 90  |
| 2         | 60.3X8.7   | <b>R-432WA-60.3X8.7S</b>   | R32X           | BS32SNX         | R-432-CFX         | WA32-60.3X8.7SX              | 2.84                      | 66  | 43  | 90  |
| 2         | 60.3X11.1  | <b>R-432WA-60.3X11.1S</b>  | R32X           | BS32SNX         | R-432-CFX         | WA32-60.3X11.1SX             | 3.04                      | 66  | 38  | 90  |
| 2         | 66X8.5     | <b>R-432WA-66X8.5S</b>     | R32X           | BS32SNX         | R-432-CFX         | WA32-66X8.5SX                | 2.45                      | 66  | 49  | 75  |
| 2 1/2     | 65X8.0     | <b>R-440WA-65X8.0S</b>     | R40X           | BS40SNX         | R-440-CFX         | WA40-65X8.0SX                | 5.10                      | 80  | 49  | 105 |
| 2 1/2     | 65X8.5     | <b>R-440WA-65X8.5S</b>     | R40X           | BS40SNX         | R-440-CFX         | WA40-65X8.5SX                | 4.59                      | 80  | 59  | 105 |
| 2 1/2     | 73X7.0     | <b>R-440WA-73X7.0S</b>     | R40X           | BS40SNX         | R-440-CFX         | WA40-73X7.0SX                | 4.20                      | 80  | 59  | 105 |
| 2 1/2     | 75X5.0     | <b>R-440WA-75X5.0S</b>     | R40X           | BS40SNX         | R-440-CFX         | WA40-75X5.0SX                | 4.37                      | 80  | 60  | 105 |
| 2 1/2     | 76.1X6.3   | <b>R-440WA-76.1X6.3S</b>   | R40X           | BS40SNX         | R-440-CFX         | WA40-76.1X6.3SX              | 4.45                      | 80  | 60  | 105 |
| 2 1/2     | 76.1X12.5  | <b>R-440WA-76.1X12.5S</b>  | R40X           | BS40SNX         | R-440-CFX         | WA40-76.1X12.5SX             | 5.17                      | 80  | 51  | 105 |
| 2 1/2     | 80X10.0    | <b>R-440WA-80X10.0S</b>    | R40X           | BS40SNX         | R-440-CFX         | WA40-80X10.0SX               | 4.40                      | 80  | 60  | 90  |
| 3         | 76.1X12.5  | <b>R-448WA-76.1X12.5S</b>  | R48X           | BS48SNX         | R-448-CFX         | WA48-76.1X12.5SX             | 8.18                      | 97  | 51  | 120 |
| 3         | 80X10.0    | <b>R-448WA-80X10.0S</b>    | R48X           | BS48SNX         | R-448-CFX         | WA48-80X10.0SX               | 8.07                      | 97  | 60  | 120 |
| 3         | 88.9X3.1   | <b>R-448WA-88.9X3.1S</b>   | R48X           | BS48SNX         | R-448-CFX         | WA48-88.9X3.1SX              | 7.18                      | 97  | 73  | 120 |
| 3         | 88.9X5.5   | <b>R-448WA-88.9X5.5S</b>   | R48X           | BS48SNX         | R-448-CFX         | WA48-88.9X5.5SX              | 7.47                      | 97  | 73  | 120 |
| 3         | 88.9X7.7   | <b>R-448WA-88.9X7.7S</b>   | R48X           | BS48SNX         | R-448-CFX         | WA48-88.9X7.7SX              | 7.67                      | 97  | 74  | 120 |
| 3         | 88.9X8.8   | <b>R-448WA-88.9X8.8S</b>   | R48X           | BS48SNX         | R-448-CFX         | WA48-88.9X8.8SX              | 7.90                      | 97  | 71  | 120 |
| 3         | 88.9X11.1  | <b>R-448WA-88.9X11.1S</b>  | R48X           | BS48SNX         | R-448-CFX         | WA48-88.9X11.1SX             | 8.34                      | 97  | 67  | 120 |
| 3         | 88.9X12.5  | <b>R-448WA-88.9X12.5S</b>  | R48X           | BS48SNX         | R-448-CFX         | WA48-88.9X12.5SX             | 8.60                      | 97  | 64  | 120 |
| 3         | 88.9X15.2  | <b>R-448WA-88.9X15.2S</b>  | R48X           | BS48SNX         | R-448-CFX         | WA48-88.9X15.2SX             | 9.00                      | 97  | 59  | 120 |
| 3         | 90X3.5     | <b>R-448WA-90X3.5S</b>     | R48X           | BS48SNX         | R-448-CFX         | WA48-90X3.5SX                | 7.19                      | 97  | 73  | 120 |
| 3         | 90X5.0     | <b>R-448WA-90X5.0S</b>     | R48X           | BS48SNX         | R-448-CFX         | WA48-90X5.0SX                | 7.50                      | 97  | 73  | 120 |
| 3         | 90X9.0     | <b>R-448WA-90X9.0S</b>     | R48X           | BS48SNX         | R-448-CFX         | WA48-90X9.0SX                | 7.85                      | 97  | 72  | 120 |
| 3         | 97X12.0    | <b>R-448WA-97X12.0S</b>    | R48X           | BS48SNX         | R-448-CFX         | WA48-97X12.0SX               | 7.65                      | 97  | 73  | 110 |
| 4         | 100X4.0    | <b>R-464WA-100X4.0S</b>    | R64X           | BS64SNX         | R-464-CFX         | WA64-100X4.0SX               | 13.44                     | 115 | 85  | 130 |
| 4         | 101.6X8.1  | <b>R-464WA-101.6X8.1S</b>  | R64X           | BS64SNX         | R-464-CFX         | WA64-101.6X8.1SX             | 12.49                     | 115 | 85  | 130 |
| 4         | 101.6X16.0 | <b>R-464WA-101.6X16.0S</b> | R64X           | BS64SNX         | R-464-CFX         | WA64-101.6X16.0SX            | 13.73                     | 115 | 85  | 120 |
| 4         | 114.3X4.5  | <b>R-464WA-114.3X4.5S</b>  | R64X           | BS64SNX         | R-464-CFX         | WA64-114.3X4.5SX             | 14.40                     | 115 | 80  | 120 |
| 4         | 114.3X12.5 | <b>R-464WA-114.3X12.5S</b> | R64X           | BS64SNX         | R-464-CFX         | WA64-114.3X12.5SX            | 12.37                     | 115 | 85  | 120 |
| 4         | 114.3X17.1 | <b>R-464WA-114.3X17.1S</b> | R64X           | BS64SNX         | R-464-CFX         | WA64-114.3X17.1SX            | 13.90                     | 115 | 85  | 120 |
| 4         | 115X4.0    | <b>R-464WA-115X4.0S</b>    | R64X           | BS64SNX         | R-464-CFX         | WA64-115X4.0SX               | 12.36                     | 115 | 85  | 120 |
| 4         | 115X15.0   | <b>R-464WA-115X15.0S</b>   | R64X           | BS64SNX         | R-464-CFX         | WA64-115X15.0SX              | 13.87                     | 115 | 85  | 120 |
| 4 1/2     | 130X15     | <b>R-872WA-130X15.0S</b>   | R72X           | BS72SNX         | R-872-CFX         | WA72-130X15SX                | 14.02                     | 130 | 100 | 125 |
| 5         | 150X15     | <b>R-880WA-150X15.0S</b>   | R80X           | BS80SNX         | R-880-CFX         | WA80-150X15SX                | 18.55                     | 150 | 120 | 110 |
| 6         | 190x20     | <b>R-896WA-190X20.0S</b>   | R96X           | PSC96-190x20CFX | R-896-CFX         | WA96-190x20.0SX              | 32.70                     | 190 | 150 | 175 |

Please change suffixes according to material/surface required

| Order code suffixes |                             |                  |
|---------------------|-----------------------------|------------------|
| Material            | Suffix surface and material | Example          |
| Steel               | S                           | R-432WA-66X8.5S  |
| Stainless steel     | SS                          | R-432WA-66X8.5SS |





**BF – Bulkhead flange**

ISO 6164

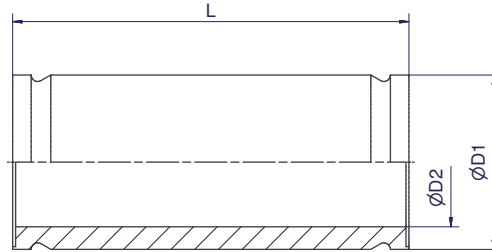
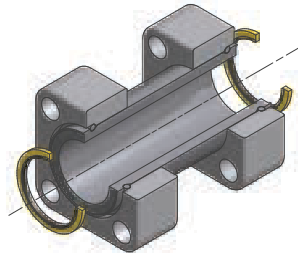

| Size<br>Inch | D1  | D2  | L   | Complete Part<br>Order code | Bulkhead Body<br>Order code | Weight body (Steel)<br>kg/1 piece |
|--------------|-----|-----|-----|-----------------------------|-----------------------------|-----------------------------------|
| 1 1/2        | 56  | 39  | 180 | <b>R-424BFS</b>             | BF24SX                      | 1.75                              |
| 2            | 66  | 49  | 210 | <b>R-432BFS</b>             | BF32SX                      | 2.45                              |
| 2 1/2        | 80  | 60  | 220 | <b>R-440BFS</b>             | BF40SX                      | 3.70                              |
| 3            | 97  | 73  | 240 | <b>R-448BFS</b>             | BF48SX                      | 7.85                              |
| 4            | 115 | 85  | 260 | <b>R-464BFS</b>             | BF64SX                      | 9.35                              |
| 5            | 150 | 120 | 260 | <b>R-880BFS</b>             | BF80SX                      | 10.53                             |

Please change suffixes according to material/surface required

| Order code suffixes |                                |           |
|---------------------|--------------------------------|-----------|
| Material            | Suffix surface<br>and material | Example   |
| Steel               | S                              | R-432BFS  |
| Stainless steel     | SS                             | R-432BFSS |

**VB – Vibra bulkhead**

ISO 6164

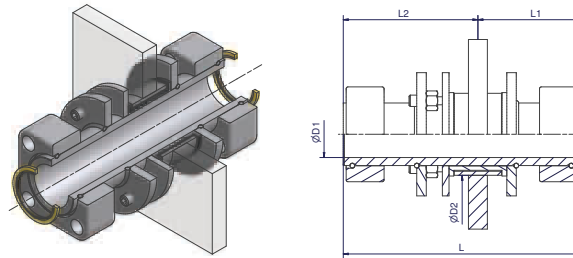

| Size<br>Inch | Tube   | D1  | D2    | L   | L1  | L2  | Complete Part<br>Order code | Weight<br>(Steel)<br>kg/1 piece |
|--------------|--------|-----|-------|-----|-----|-----|-----------------------------|---------------------------------|
| 2            | 66X8.5 | 66  | 86.5  | 250 | 110 | 140 | <b>R-432VBCF</b>            | 6.52                            |
| 2 1/2        | 80X10  | 80  | 100.5 | 260 | 115 | 145 | <b>R-440VBCF</b>            | 9.32                            |
| 3            | 97X12  | 97  | 117.5 | 280 | 125 | 155 | <b>R-448VBCF</b>            | 16.12                           |
| 4            | 115X15 | 115 | 135.5 | 300 | 135 | 165 | <b>R-464VBCF</b>            | 27.62                           |

Please change suffixes according to material/surface required

| Order code suffixes             |                             |           |
|---------------------------------|-----------------------------|-----------|
| Material                        | Suffix surface and material | Example   |
| Steel, zinc plated, Cr(VI)-free | CF                          | R-432VBCF |
| Stainless steel                 | SS                          | R-432VBSS |



## RF – Reducer flange

ISO 6164

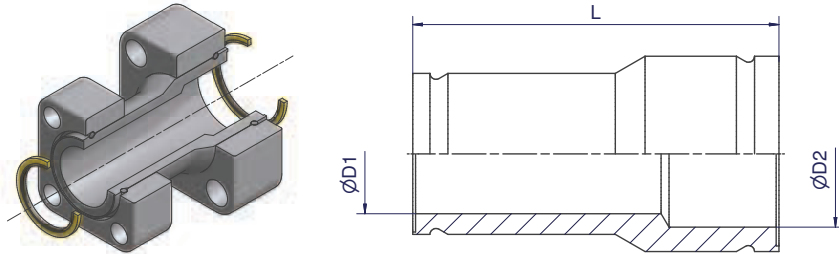

| Size<br>Inch  | D1 | D2  | L   | Complete Part<br>Order code | Reducer Body<br>Order code | Weight body<br>(Steel)<br>kg/1 piece |
|---------------|----|-----|-----|-----------------------------|----------------------------|--------------------------------------|
| 2 - 1 1/4     | 30 | 49  | 130 | <b>R-432-420RFCF</b>        | <b>RF32-20CFX</b>          | 1.3                                  |
| 2 - 1 1/2     | 39 | 49  | 130 | <b>R-432-424RFCF</b>        | <b>RF32-24CFX</b>          | 1.4                                  |
| 2 1/2 - 1 1/2 | 39 | 60  | 150 | <b>R-440-424RFCF</b>        | <b>RF40-24CFX</b>          | 2.1                                  |
| 2 1/2 - 2     | 49 | 60  | 150 | <b>R-440-432RFCF</b>        | <b>RF40-32CFX</b>          | 2.2                                  |
| 3 - 2         | 49 | 73  | 180 | <b>R-448-432RFCF</b>        | <b>RF48-32CFX</b>          | 3.4                                  |
| 3 - 2 1/2     | 60 | 73  | 180 | <b>R-448-440RFCF</b>        | <b>RF48-40CFX</b>          | 3.7                                  |
| 4 - 3         | 73 | 85  | 200 | <b>R-464-448RFCF</b>        | <b>RF64-48CFX</b>          | 6.1                                  |
| 5 - 3         | 73 | 120 | 200 | <b>R-880-448RFCF</b>        | <b>RF80-48CFX</b>          | 8.0                                  |

Other sizes on request

Please change suffixes according to material/surface required

| Order code suffixes             |                             |               |
|---------------------------------|-----------------------------|---------------|
| Material                        | Suffix surface and material | Example       |
| Steel, zinc plated, Cr(VI)-free | CF                          | R-432-424RFCF |
| Stainless steel                 | SS                          | R-432-424RFSS |

**FB90 – 90° Flange bend**

ISO 6164

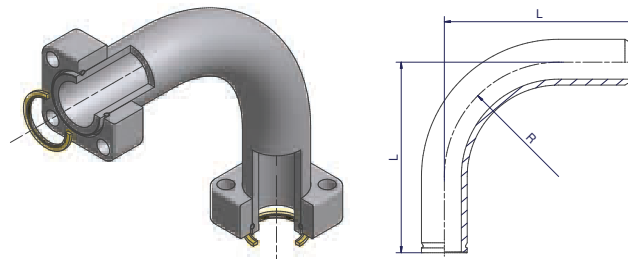

| Size<br>Inch | Tube    | L   | R   | Complete Part<br>Order code | 90° Flange Bend<br>Order code | Weight body<br>(Steel)<br>kg/1 piece |
|--------------|---------|-----|-----|-----------------------------|-------------------------------|--------------------------------------|
| 2            | 66X8.5  | 275 | 165 | <b>R-432FB90S</b>           | <b>FB90-32SX</b>              | 5.72                                 |
| 2 1/2        | 80X10.0 | 370 | 200 | <b>R-440FB90S</b>           | <b>FB90-40SX</b>              | 11.20                                |
| 3            | 97X12   | 450 | 243 | <b>R-448FB90S</b>           | <b>FB90-48SX</b>              | 19.90                                |

Please change suffixes according to material/surface required

| Order code suffixes             |                             |             |            |
|---------------------------------|-----------------------------|-------------|------------|
| Material                        | Suffix surface and material | Example     | Comments   |
| Steel, zinc plated, Cr(VI)-free | S                           | R-432FB90S  |            |
| Stainless steel                 | SS                          | R-432FB90SS | on request |



## FB45 – 45° Flange bend

ISO 6164

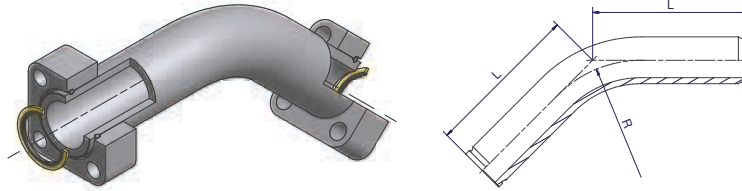

| Size<br>Inch | Tube    | L   | R   | Complete Part<br>Order code | 45° Flange Bend<br>Order code | Weight body<br>(Steel)<br>kg/1 piece |
|--------------|---------|-----|-----|-----------------------------|-------------------------------|--------------------------------------|
| 2            | 66X8.5  | 220 | 165 | <b>R-432FB45S</b>           | <b>FB45-32SX</b>              | 5.16                                 |
| 2 1/2        | 80X10.0 | 240 | 200 | <b>R-440FB45S</b>           | <b>FB45-40SX</b>              | 8.07                                 |
| 3            | 97X12   | 260 | 243 | <b>R-448FB45S</b>           | <b>FB45-48SX</b>              | 12.70                                |

Available on request

Please change suffixes according to material/surface required

| Order code suffixes             |                                |             |            |
|---------------------------------|--------------------------------|-------------|------------|
| Material                        | Suffix surface<br>and material | Example     | Comments   |
| Steel, zinc plated, Cr(VI)-free | S                              | R-432FB45S  |            |
| Stainless steel                 | SS                             | R-432FB45SS | on request |

**LF – Elbow flange**

ISO 6164

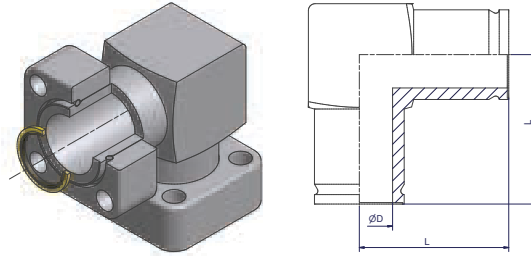

| Size<br>Inch | D  | L   | Complete Part<br>Order code | Elbow Flange<br>body<br>Order code | Weight body<br>(Steel)<br>kg/1 piece |
|--------------|----|-----|-----------------------------|------------------------------------|--------------------------------------|
| 2            | 49 | 110 | <b>R-432LFCF</b>            | <b>LF32CFX</b>                     | 4.02                                 |
| 2 1/2        | 60 | 130 | <b>R-440LFCF</b>            | <b>LF40CFX</b>                     | 5.79                                 |
| 3            | 73 | 160 | <b>R-448LFCF</b>            | <b>LF48CFX</b>                     | 10.76                                |

Please change suffixes according to material/surface required

| Order code suffixes             |                                |           |
|---------------------------------|--------------------------------|-----------|
| Material                        | Suffix surface<br>and material | Example   |
| Steel, zinc plated, Cr(VI)-free | CF                             | R-432LFCF |
| Stainless steel                 | SS                             | R-432LFSS |



**TF – TEE flange**

ISO 6164

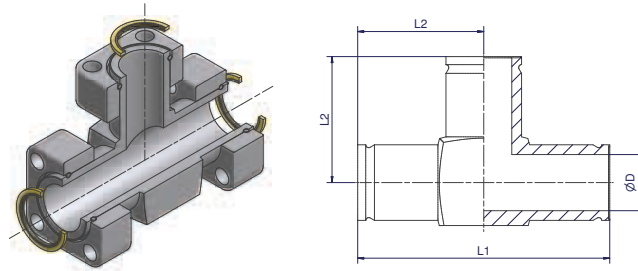

| Size<br>Inch | D  | L1  | L2  | Complete Part<br>Order code | Tee Flange<br>body<br>Order code | Weight body<br>(Steel)<br>kg/1 piece |
|--------------|----|-----|-----|-----------------------------|----------------------------------|--------------------------------------|
| 2            | 49 | 220 | 110 | <b>R-432TFCF</b>            | <b>TF32CFX</b>                   | 4.53                                 |
| 2 1/2        | 60 | 260 | 130 | <b>R-440TFCF</b>            | <b>TF40CFX</b>                   | 8.70                                 |
| 3            | 73 | 320 | 160 | <b>R-448TFCF</b>            | <b>TF48CFX</b>                   | 12.81                                |

Please change suffixes according to material/surface required

| Order code suffixes             |                                |           |
|---------------------------------|--------------------------------|-----------|
| Material                        | Suffix surface<br>and material | Example   |
| Steel, zinc plated, Cr(VI)-free | CF                             | R-432TFCF |
| Stainless steel                 | SS                             | R-432TFSS |

**LB – Flange L-block**

ISO 6164

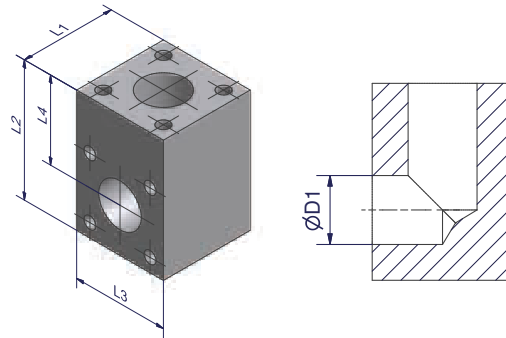

| Size<br>Inch | D1 | L1  | L2  | L3  | L4  | Weight (Steel)<br>kg/1 piece | Order code      |
|--------------|----|-----|-----|-----|-----|------------------------------|-----------------|
| 2            | 50 | 100 | 140 | 100 | 90  | 8.72                         | <b>LB432CFX</b> |
| 2 1/2        | 60 | 120 | 160 | 120 | 100 | 14.10                        | <b>LB440CFX</b> |
| 3            | 73 | 150 | 200 | 150 | 125 | 28.10                        | <b>LB448SX</b>  |
| 4            | 99 | 180 | 240 | 180 | 150 | 48.80                        | <b>LB464SX</b>  |

Please change suffixes according to material/surface required

| Order code suffixes             |                             |          |
|---------------------------------|-----------------------------|----------|
| Material                        | Suffix surface and material | Example  |
| Steel, zinc plated, Cr(VI)-free | CF                          | LB432CFX |
| Steel                           | S                           | LB432SX  |
| Stainless steel                 | SS                          | LB432SSX |





## TB – Flange T-block

ISO 6164

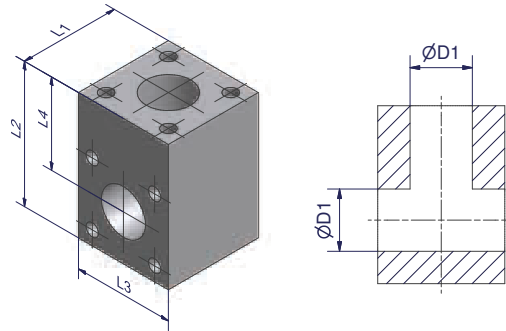

| Size<br>Inch | D1  | L1  | L2  | L3  | L4  | Weight (Steel)<br>kg/1 piece | Order code      |
|--------------|-----|-----|-----|-----|-----|------------------------------|-----------------|
| 2            | 49  | 100 | 140 | 100 | 90  | 8.03                         | <b>TB432CFX</b> |
| 2 1/2        | 60  | 120 | 160 | 120 | 100 | 12.90                        | <b>TB440CFX</b> |
| 3            | 73  | 150 | 200 | 150 | 125 | 25.80                        | <b>TB448SX</b>  |
| 4            | 85  | 180 | 240 | 180 | 150 | 40.70                        | <b>TB464SX</b>  |
| 5            | 120 | 260 | 300 | 260 | 170 | 122.0                        | <b>TB880SX</b>  |

Please change suffixes according to material/surface required

| Order code suffixes             |                                   |          |
|---------------------------------|-----------------------------------|----------|
| Material                        | Suffix<br>surface<br>and material | Example  |
| Steel, zinc plated, Cr(VI)-free | CF                                | TB432CFX |
| Steel                           | S                                 | TB432SX  |
| Stainless steel                 | SS                                | TB432SSX |

**TBR – Flange T-block reducer**

ISO 6164

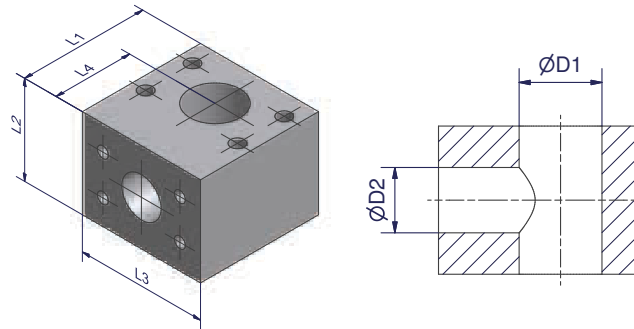

| Size<br>Inch | D1 | D2 | L1  | L2  | L3  | L4  | Weight (Steel)<br>kg/1 piece | Order code               |
|--------------|----|----|-----|-----|-----|-----|------------------------------|--------------------------|
| 2 1/2 - 2    | 60 | 49 | 150 | 100 | 120 | 90  | 10.2                         | <b>TBR440-432-440CFX</b> |
| 3 - 2 1/2    | 73 | 60 | 185 | 120 | 150 | 110 | 19.2                         | <b>TBR448-440-448CFX</b> |
| 3 - 2        | 73 | 49 | 175 | 100 | 150 | 100 | 15.2                         | <b>TBR448-432-448CFX</b> |
| 4 - 3        | 85 | 73 | 225 | 180 | 180 | 135 | 35.2                         | <b>TBR464-448-464SX</b>  |
| 4 - 2 1/2    | 85 | 60 | 215 | 120 | 180 | 125 | 26.9                         | <b>TBR464-440-464SX</b>  |
| 4 - 2        | 85 | 49 | 200 | 100 | 180 | 110 | 21.0                         | <b>TBR464-432-464SX</b>  |

Please change suffixes according to material/surface required

| Order code suffixes             |                                   |                   |
|---------------------------------|-----------------------------------|-------------------|
| Material                        | Suffix<br>surface<br>and material | Example           |
| Steel, zinc plated, Cr(VI)-free | CF                                | TBR448-432-448CFX |
| Steel                           | S                                 | TBR448-432-448SX  |
| Stainless steel                 | SS                                | TBR448-432-448SSX |



## BFV – Blind flange

ISO 6164

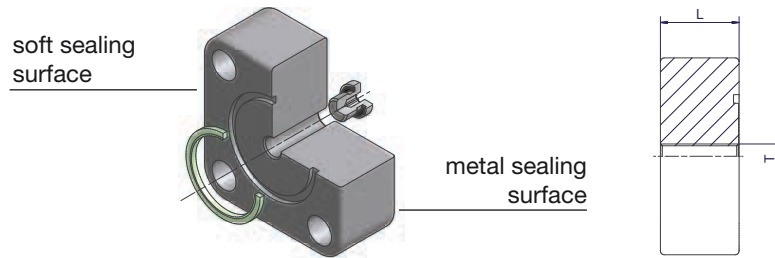

| Size<br>Inch | L    | T     | Weight<br>(Steel)<br>kg/1 piece | Flange incl.<br>VSTI-ED and F37 Seal<br>Order code |
|--------------|------|-------|---------------------------------|--|
| 2            | 40.0 | G 1/4 | 2.75                            | <b>F37-432BFVCF</b>                                |
| 2 1/2        | 50.0 | G 1/4 | 4.90                            | <b>F37-440BFVCF</b>                                |
| 3            | 52.0 | G 1/4 | 8.15                            | <b>F37-448BFVCF</b>                                |
| 4            | 70.0 | G 1/4 | 11.55                           | <b>F37-464BFVCF</b>                                |
| 5            | 50.0 | G 1/4 | 16.74                           | <b>F37-880BFVCF</b>                                |

Please change suffixes according to material/surface required

| Order code suffixes             |                                   |              |
|---------------------------------|-----------------------------------|--------------|
| Material                        | Suffix<br>surface<br>and material | Example      |
| Steel, zinc plated, Cr(VI)-free | CF                                | F37-432BFVCF |
| Stainless steel                 | SS                                | F37-432BFVSS |

**BS – Bonded seal**

ISO 6164

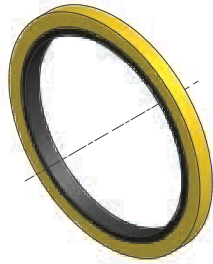

| Size<br>Inch | Steel          | Stainless Steel |
|--------------|----------------|-----------------|
| 2            | <b>BS32SNX</b> | <b>BS32SSNX</b> |
| 2 1/2        | <b>BS40SNX</b> | <b>BS40SSNX</b> |
| 3            | <b>BS48SNX</b> | <b>BS48SSNX</b> |
| 4            | <b>BS64SNX</b> | <b>BS64SSNX</b> |
| 5            | <b>BS80SNX</b> | <b>BS80SSNX</b> |

Sealing: NBR  
Other sealing materials like FKM on request

**F37S – F37 Seal**

ISO 6164

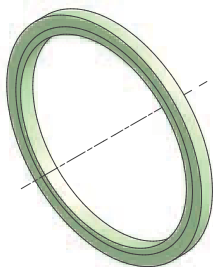

| Size<br>Inch | F37 Seal       |
|--------------|----------------|
| 2            | <b>F37S32X</b> |
| 2 1/2        | <b>F37S40X</b> |
| 3            | <b>F37S48X</b> |
| 4            | <b>F37S64X</b> |
| 5            | <b>F37S80X</b> |

Sealing: Polyurethane  
Material properties and applications see page 18



**A0 – Adapter bonded seal/F37 seal/O-Ring**

ISO 6164

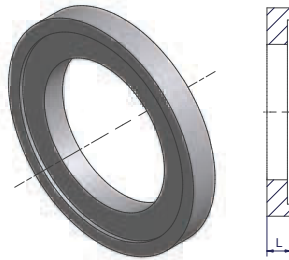

| Size<br>Inch | L | Weight<br>(Steel)<br>kg/1 piece | Adapter*<br>Order code |
|--------------|---|---------------------------------|------------------------|
| 2            | 7 | 0.10                            | <b>AO32CFX</b>         |
| 2 1/2        | 7 | 0.14                            | <b>AO40CFX</b>         |
| 3            | 7 | 0.20                            | <b>AO48CFX</b>         |
| 4            | 7 | 0.35                            | <b>AO64CFX</b>         |
| 5            | 7 | 0.32                            | <b>AO80CFX</b>         |

\*Part excluding seals

Please change suffixes according to material/surface required

| Order code suffixes             |                                   |         |
|---------------------------------|-----------------------------------|---------|
| Material                        | Suffix<br>surface<br>and material | Example |
| Steel, zinc plated, Cr(VI)-free | CF                                | AO32CFX |
| Stainless steel                 | SS                                | AO32SSX |

**TBT – Tee between bonded seal**

ISO 6164

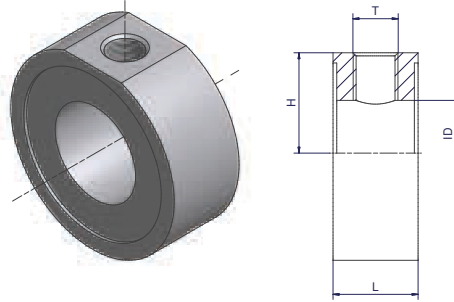

| Size<br>Inch | L  | H  | T     | ID | Bolt ISO 4762 | Weight<br>(Steel)<br>kg/1 piece | Order code          |
|--------------|----|----|-------|----|---------------|---------------------------------|---------------------|
| 2            | 25 | 35 | G 1/4 | 41 | ZYLS12X110    | 0.51                            | <b>TBT32-1/4CFX</b> |
| 2            | 40 | 34 | G 1/2 | 38 | ZYLS12X130    | 0.87                            | <b>TBT32-1/2CFX</b> |
| 2 1/2        | 30 | 42 | G 1/4 | 60 | ZYLS12X150    | 0.63                            | <b>TBT40-1/4CFX</b> |
| 3            | 30 | 50 | G 1/4 | 72 | ZYLS12x150    | 0.90                            | <b>TBT48-1/4CFX</b> |

\*Part excluding seals  
For testpoints and diagnostic test equipment see catalogue 4100, Industrial Tube Fittings Europe

Alternative versions on request



**TFVB**

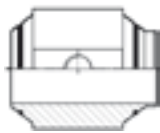

**TTB**

Please change suffixes according to material/surface required

| Order code suffixes             |                                   |              |
|---------------------------------|-----------------------------------|--------------|
| Material                        | Suffix<br>surface<br>and material | Example      |
| Steel, zinc plated, Cr(VI)-free | CF                                | TBT32-1/2CFX |
| Stainless steel                 | SS                                | TBT32-1/2SSX |



## Bolts and nuts for flange

ISO 6164



### F37 Flare Flange

| Size<br>Inch | Flange      | F37 Seal / Flat Face / Bonded Seal |                       | Nut             |
|--------------|-------------|------------------------------------|-----------------------|-----------------|
|              |             | Bolts<br>Tube to Port              | Bolts<br>Tube to Tube |                 |
| 2            | F37-432-CFX | 4 x ZYLS16X65                      | 4 x ZYLS16X110        | 4 x ISO4032-M16 |
| 2 1/2        | F37-440-CFX | 4 x ZYLS20X80                      | 4 x ZYLS20X140        | 4 x ISO4032-M20 |
| 3            | F37-448-CFX | 4 x ZYLS24X90                      | 4 x ZYLS24X150        | 4 x ISO4032-M24 |

### Retaining Ring Flange

| Size<br>Inch | Flange        | Flat Face / Bonded Seal |                       | Nut              |
|--------------|---------------|-------------------------|-----------------------|------------------|
|              |               | Bolts<br>Tube to Port   | Bolts<br>Tube to Tube |                  |
| 2            | R-432-CFX     | 4 x ZYLS16X65           | 4 x ZYLS16X110        | 4 x ISO4032-M16  |
| 2 1/2        | R-440-CFX     | 4 x ZYLS20X80           | 4 x ZYLS20X140        | 4 x ISO4032-M20  |
| 3            | R-448-CFX     | 4 x ZYLS24X90           | 4 x ZYLS24X150        | 4 x ISO4032-M24  |
| 4            | R-464-CFX     | 4 x ZYLS30X120          | 4 x ZYLS30X190        | 4 x ISO4032-M30  |
| 4 1/2        | R-872-CFX     | 8 x ZYLS20X90           | 8 x ZYLS20X160        | 8 x ISO4032-M20  |
| 5            | R-880-CFX     | 8 x ZYLS24X110          | 8 x ZYLS24X190        | 8 x ISO4032-M24  |
| 6            | R-896-CFX     | 8 x ZYLS30X160          | 8 x ZYLS30X230        | 8 x ISO4032-M30  |
| 8            | R-8128-CFX    | 8 x ZYLS36X170          | 8 x ZYLS36X250        | 8 x ISO4032-M36  |
| 10           | R-8160273-CFX | 12 x ZYLS36X180         | 12 x ZYLS36X250       | 12 x ISO4032-M36 |

Bolts and nuts must be ordered separately

Latest information about nuts and bolts see [www.parker.com/tfde/servicemanuals/userguides](http://www.parker.com/tfde/servicemanuals/userguides)

Please add the suffixes according to the bolt quality

| Quality | Steel             |                  | Stainless Steel  |
|---------|-------------------|------------------|------------------|
|         | 8.8               | 10.9             | A4-80X           |
| Bolt    | ZYLS16X60X        | ZYLS16X60109X    | ZYLS16X60A4-80X  |
| Nut     | ISO-4032-M12-8VZX | ISO-4032-M12-10X | ISO-4032-M12-80X |

\* Bolt quality 10.9 recommended.  
Bolt quality 8.8 can affect the pressure capability.

**KH – Ball valve**

400 bar Female BSPP Thread (ISO 1179-1)

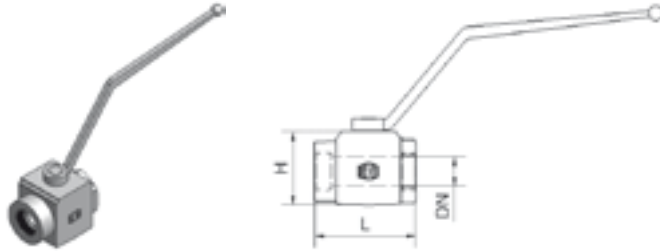

Material Steel

| Size Inch | DN | L   | H   | Order code  | Weight (Steel) kg/1 piece | W.P. bar |
|-----------|----|-----|-----|-------------|---------------------------|----------|
| 2         | 50 | 129 | 104 | <b>KH2X</b> | 5                         | 400      |

Please change suffixes according to material/surface required

| Order code suffixes             |                             |         |                 |
|---------------------------------|-----------------------------|---------|-----------------|
| Material                        | Suffix surface and material | Example | Comments        |
| Steel, zinc plated, Cr(VI)-free | CF                          | KH2CFX  | only ball valve |
| Steel                           |                             | KH2X    | only ball valve |
| Stainless steel                 | 71                          | KH271X  | only ball valve |

|              | Materials      |                 |
|--------------|----------------|-----------------|
| Body         | Steel          | Stainless Steel |
| Ball         | Steel          | Stainless Steel |
| Stem         | Steel          | Stainless Steel |
| Ball seats   | POM            | POM             |
| O-Ring       | NBR            | NBR             |
| Tmin / T max | -30°C / 100 °C | -30°C / 100°C   |





**KH – Ball valve drilled and tapped for ISO 6164 flanges**

ISO 6164

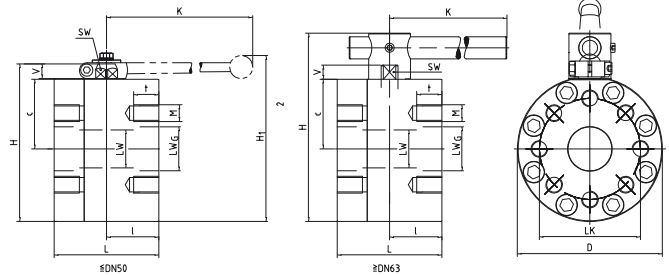

Material Steel

| Order Code          | PN (bar) | DN  | LW  | LWG | L   | I   | D   | H   | c   | V  | K   | SW | LK  | M1     | t    | H1  | Material Code | Lever | Weight kg |
|---------------------|----------|-----|-----|-----|-----|-----|-----|-----|-----|----|-----|----|-----|--------|------|-----|---------------|-------|-----------|
| <b>KH432-38CF</b>   | 400      | 50  | 38  | 35  | 116 | 58  | 198 | 210 | 94  | 17 | 320 | 17 | 98  | 4x M16 | 24.5 | 219 | <b>212A</b>   | Al    | 24.90     |
| <b>KH432-48CF</b>   | 400      | 50  | 48  | 43  | 116 | 58  | 198 | 210 | 94  | 17 | 320 | 17 | 98  | 4x M16 | 25.5 | 219 | <b>282A</b>   | Al    | 24.90     |
| <b>KH440-48CF</b>   | 400      | 56  | 48  | 53  | 123 | 58  | 198 | 210 | 94  | 17 | 320 | 17 | 118 | 4x M20 | 31.0 | 219 | <b>282A</b>   | Al    | 26.60     |
| <b>KH448-63CF</b>   | 350      | 65  | 65  | 63  | 150 | 75  | 208 | 270 | 100 | 20 | 600 | 16 | 145 | 4x M24 | 36.0 | -   | <b>282A</b>   | St    | 36.00     |
| <b>KH464-76CF</b>   | 350      | 80  | 76  | 76  | 140 | 70  | 215 | 279 | 100 | 26 | 600 | 19 | 175 | 4x M30 | 35.0 | -   | <b>282A</b>   | St    | 34.26     |
| <b>KH872-100CF</b>  | 350      | 100 | 100 | 100 | 170 | 75  | 260 | 327 | 122 | 26 | 900 | 24 | 175 | 8x M20 | 28.0 | -   | <b>282A</b>   | St    | 70.00     |
| <b>KH880-118CF</b>  | 350      | 125 | 118 | 118 | 210 | 110 | 300 | 379 | 140 | 32 | 900 | 36 | 205 | 8x M24 | 36.0 | -   | <b>282A</b>   | St    | 209.00    |
| <b>KH896-150CF</b>  | 350      | 150 | 150 | 150 | 285 | 130 | 390 | 475 | 190 | 32 | 900 | 36 | 245 | 8x M30 | 46.0 | -   | <b>282A</b>   | St    | 225.00    |
| <b>KH8128-200CF</b> | 350      | 200 | 192 | 200 | 378 | 150 | 456 | 598 | 223 | 61 | 940 | 46 | 315 | 8x M36 | 55.0 | -   | <b>282A</b>   | St    | 395.00    |

Please change suffixes according to material/surface required

| Order code suffixes             |                             |            |
|---------------------------------|-----------------------------|------------|
| Material                        | Suffix surface and material | Example    |
| Steel, zinc plated, Cr(VI)-free | CF                          | KH432-38CF |
| Stainless steel                 | SS                          | KH432-38SS |

|              | Material      |                 |
|--------------|---------------|-----------------|
|              | 212A          | 282A            |
| Body         | Steel         | Steel           |
| Ball         | Steel         | Steel           |
| Stem         | Steel         | Stainless Steel |
| Ball seats   | POM           | POM             |
| O-Ring       | NBR           | NBR             |
| Tmin / T max | -10°C / 100°C | -30°C / 100°C   |

ENGINEERING YOUR SUCCESS.

**KH – Ball valve drilled and tapped for ISO 6164 flanges**

ISO 6164

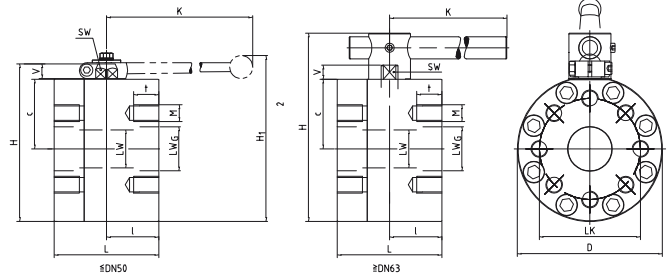

Material Stainless Steel

| Order Code   | PN (bar) | DN  | LW  | LWG | L   | I   | D   | H   | c   | V  | K   | SW | LK  | M1     | t    | H1  | Lever | Weight kg |
|--------------|----------|-----|-----|-----|-----|-----|-----|-----|-----|----|-----|----|-----|--------|------|-----|-------|-----------|
| KH432-38SS   | 400      | 50  | 38  | 35  | 116 | 58  | 198 | 210 | 94  | 17 | 320 | 17 | 98  | 4x M16 | 25.5 | 219 | Al    | 24.90     |
| KH432-48SS   | 400      | 50  | 48  | 43  | 116 | 58  | 198 | 210 | 94  | 17 | 320 | 17 | 98  | 4x M16 | 25.5 | 219 | Al    | 24.90     |
| KH440-48SS   | 400      | 56  | 48  | 53  | 123 | 58  | 198 | 210 | 94  | 17 | 320 | 17 | 118 | 4x M20 | 31.0 | 219 | Al    | 26.60     |
| KH448-63SS   | 350      | 65  | 65  | 63  | 150 | 75  | 208 | 270 | 100 | 20 | 600 | 16 | 145 | 4x M24 | 36.0 | -   | St    | 36.00     |
| KH464-76SS   | 350      | 80  | 76  | 76  | 140 | 70  | 215 | 279 | 100 | 26 | 600 | 19 | 175 | 4x M30 | 35.0 | -   | St    | 34.26     |
| KH464-88SS   | 350      | 90  | 88  | 88  | 200 | 100 | 258 | 326 | 122 | 26 | 900 | 24 | 160 | 4x M24 | 40.0 | -   | St    | 53.00     |
| KH872-100SS  | 350      | 100 | 100 | 100 | 170 | 75  | 260 | 327 | 122 | 26 | 900 | 24 | 175 | 8x M20 | 28.0 | -   | St    | 70.00     |
| KH880-118SS  | 350      | 125 | 118 | 118 | 210 | 110 | 300 | 379 | 140 | 32 | 900 | 36 | 205 | 8x M24 | 36.0 | -   | St    | 209.00    |
| KH896-150SS  | 350      | 150 | 132 | 132 | 285 | 130 | 390 | 475 | 190 | 32 | 900 | 36 | 245 | 8x M30 | 46.0 | -   | St    | 225.00    |
| KH896-150SS  | 350      | 150 | 150 | 150 | 285 | 130 | 390 | 475 | 190 | 32 | 900 | 36 | 245 | 8x M30 | 46.0 | -   | St    | 225.00    |
| KH8128-200SS | 350      | 200 | 192 | 200 | 378 | 150 | 456 | 598 | 223 | 61 | 940 | 46 | 315 | 8x M36 | 55.0 | -   | St    | 395.00    |

Please change suffixes according to material/surface required

| Order code suffixes             |                             |            |
|---------------------------------|-----------------------------|------------|
| Material                        | Suffix surface and material | Example    |
| Steel, zinc plated, Cr(VI)-free | CF                          | KH432-38CF |
| Stainless steel                 | SS                          | KH432-38SS |

|              | Material 442A   |
|--------------|-----------------|
| Body         | Stainless Steel |
| Ball         | Stainless Steel |
| Stem         | Stainless Steel |
| Ball seats   | POM             |
| O-Ring       | NBR             |
| Tmin / T max | -30°C / 100°C   |



**KH-R – Ball valve with ISO 6164 flanges**

ISO 6164

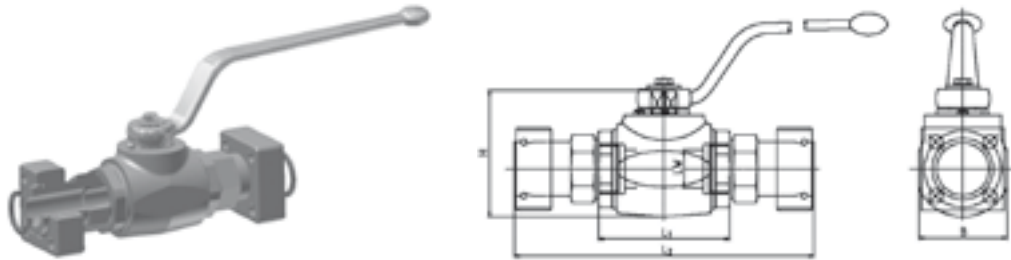

Material Steel

| Size Inch | LW | L1  | L2    | B   | H   | Complete part Order code | Valve body Order code | Weight (Steel) kg/1 piece | W.P. bar |
|-----------|----|-----|-------|-----|-----|--------------------------|-----------------------|---------------------------|----------|
| 2         | 48 | 140 | 348.0 | 118 | 138 | <b>KH-R-432-48CF</b>     | KH-R-32-48CF          | 15.2                      | 400      |

Material Stainless Steel

| Size Inch | LW | L1  | L2    | B   | H   | Complete part Order code | Valve body Order code | Weight (Steel) kg/1 piece | W.P. bar |
|-----------|----|-----|-------|-----|-----|--------------------------|-----------------------|---------------------------|----------|
| 2         | 48 | 140 | 348.0 | 132 | 145 | <b>KH-R-432-48SS</b>     | KH-R-32-48SS          | 17.3                      | 400      |

Please change suffixes according to material/surface required

| Order code suffixes             |                             |               |
|---------------------------------|-----------------------------|---------------|
| Material                        | Suffix surface and material | Example       |
| Steel, zinc plated, Cr(VI)-free | CF                          | KH-R-432-48CF |
| Stainless steel                 | SS                          | KH-R-432-48SS |

|              | Materials      |                 |
|--------------|----------------|-----------------|
| Body         | Steel          | Stainless Steel |
| Ball         | Steel          | Stainless Steel |
| Stem         | Steel          | Stainless Steel |
| Ball seats   | POM            | POM             |
| O-Ring       | NBR            | NBR             |
| Tmin / T max | -20°C / 100 °C | -30°C / 100°C   |

**RHD-R – Non return valves**

ISO 6164

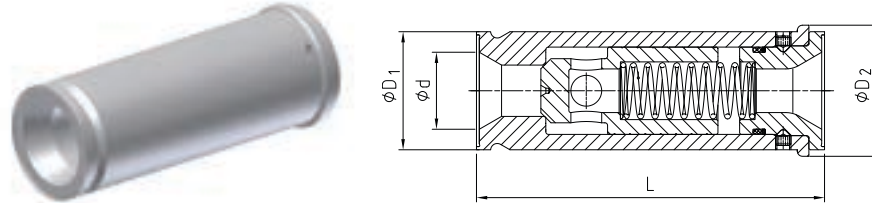

Material Steel

| Size<br>Inch | L     | D1 | D2   | d  | Complete part<br>Order code | Valve body<br>Order code | Weight body<br>(Steel)<br>kg/1 piece | W.P.<br>bar |
|--------------|-------|----|------|----|-----------------------------|--------------------------|--------------------------------------|-------------|
| 2            | 180.1 | 66 | 70.5 | 49 | <b>RHD-R-432-0.5BCF</b>     | RHD-R-32-0.5BCF          | 2.54                                 | 420         |
| 2 1/2        | 190.0 | 80 | 84.5 | 60 | <b>RHD-R-440-0.5BCF</b>     | RHD-R-40-0.5BCF          | 3.89                                 |             |

Opening pressure 0.5 bar  
Other pressure rates on request

Please change suffixes according to material/surface required

| Order code suffixes             |                                   |                 |
|---------------------------------|-----------------------------------|-----------------|
| Material                        | Suffix<br>surface<br>and material | Example         |
| Steel, zinc plated, Cr(VI)-free | CF                                | RHD-R-32-0.5BCF |
| Stainless steel                 | SS                                | RHD-R-32-0.5BSS |

|              | Materials      |
|--------------|----------------|
| Body         | Steel          |
| O-Ring       | NBR            |
| Tmin / T max | -10°C / 100 °C |





# Flange mounted valves

## Flange mounted valves

### Characteristics

#### Flange Mounted Valves

Parker offers a wide range of flange mounted valves in four sizes (3/4", 1", 1 1/4", 1 1/2") and various functions.



#### Pressure relief valves

2- and 3-port configurations  
SAE 3000 (SAE 61) and SAE 6000 (SAE 62)

Functions:

- Pressure relief valve R5V
- Pressure reducing valve R5R
- Pressure unloading valve R5U

#### Check valves

2-port configuration  
SAE 3000 (SAE 61) and SAE 6000 (SAE 62)

Functions:

- Direct operated check valve C5V
- Pilot operated check valve C5P



#### Flow valves

2- and 3-port configurations  
SAE 3000 (SAE 61)

Functions:

- Proportional throttle valve F5C
- Pressure compensators
  - 2-port R5A
  - 3-port R5P

#### Logic valves

2- and 3-port configurations  
SAE 3000 (SAE 61)

Function:

- 2/2-way seat valve D5S



## Characteristics C5V

Direct operated check valves series C5V provide free flow in one direction and block the flow in the counter direction. The SAE flanges allow to mount the C5V directly on the pressure port of pumps for protection against pressure shocks from the system.



### Features

- Direct operated check valve
- SAE61 and SAE62 flange
- 4 sizes (SAE 3/4", 1", 1 1/4", 1 1/2")
- 3 springs
- 5 options for body sealing

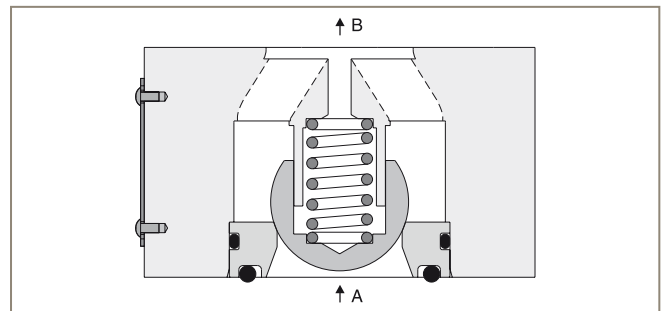

### Technical data

| General                 |               | 06 (3/4")                                   | 08 (1") | 10 (1 1/4") | 12 (1 1/2") |
|-------------------------|---------------|---|---------|-------------|-------------|
| Size                    |               |   |         |             |             |
| Mounting                |               | 2-port inline flange (SAE61 and 62)         |         |             |             |
| Mounting position       |               | unrestricted                                |         |             |             |
| Ambient temperature     | [°C]          | -20...+50                                   |         |             |             |
| MTTFD value             | [years]       | 150   |         |             |             |
| Weight                  | [kg]          | 0.6   | 0.9     | 1.3         | 1.8         |
| Hydraulic               |               |   |         |             |             |
| Max. operating pressure | [bar]         |   |         |             |             |
|                         | SAE61         | 350   | 350     | 280         | 210         |
|                         | SAE62         | 420   | 420     | 420         | 420         |
| Pressure stages         | [bar]         |   |         |             |             |
| Nominal flow            | [l/min]       | 100   | 200     | 400         | 750         |
| Fluid                   |               | Hydraulic oil as per DIN 51524...525        |         |             |             |
| Fluid temperature       | [°C]          | -20...+80                                   |         |             |             |
| Viscosity permitted     | [cSt]/[mm²/s] | 10...650                                    |         |             |             |
| Viscosity recommended   | [cSt]/[mm²/s] | 30  |         |             |             |
| Filtration              |               | ISO 4406 (1999) 18/16/13 (acc. NAS 1638: 7) |         |             |             |

## Characteristics C5V

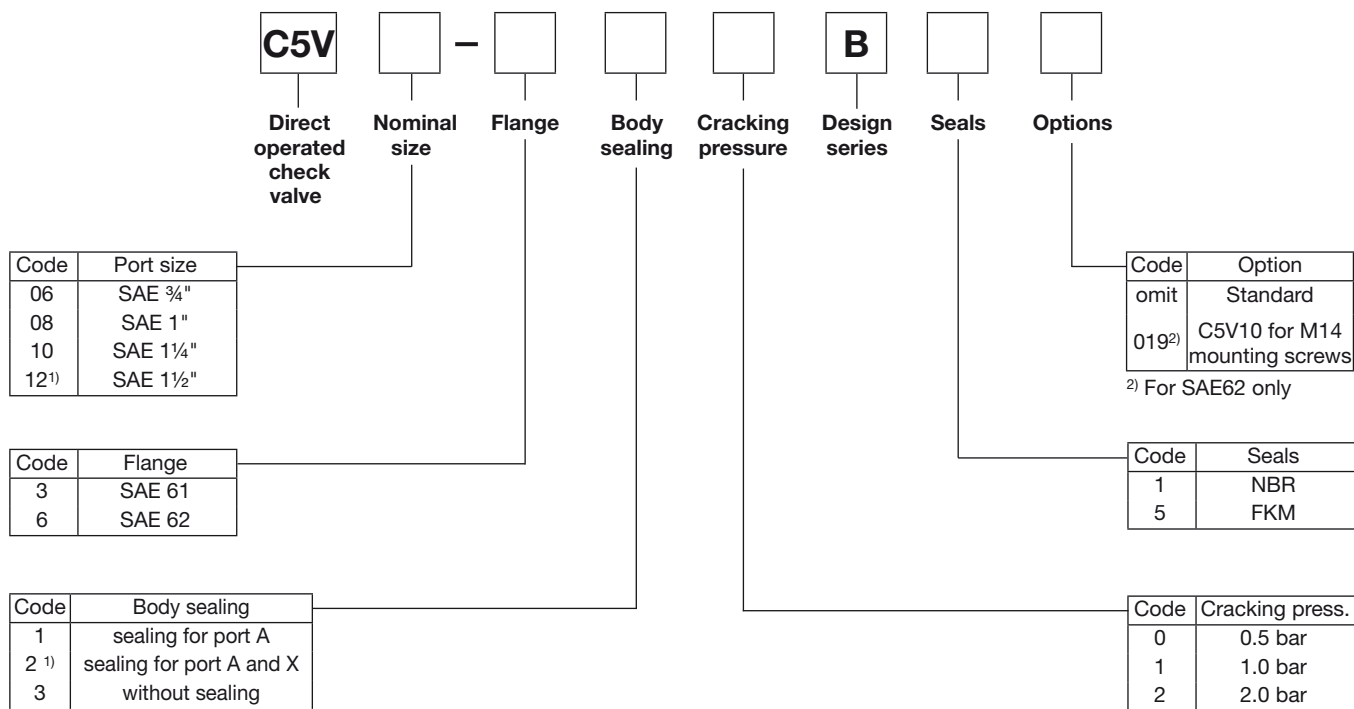

<sup>1)</sup> For combination with R5U unloading valve (SAE61 only)

<sup>2)</sup> For SAE62 only





Characteristics C5V

C5V06

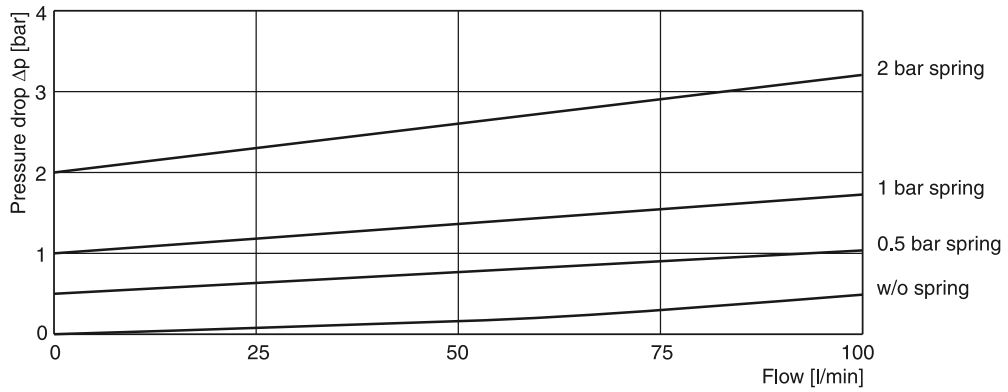

C5V08

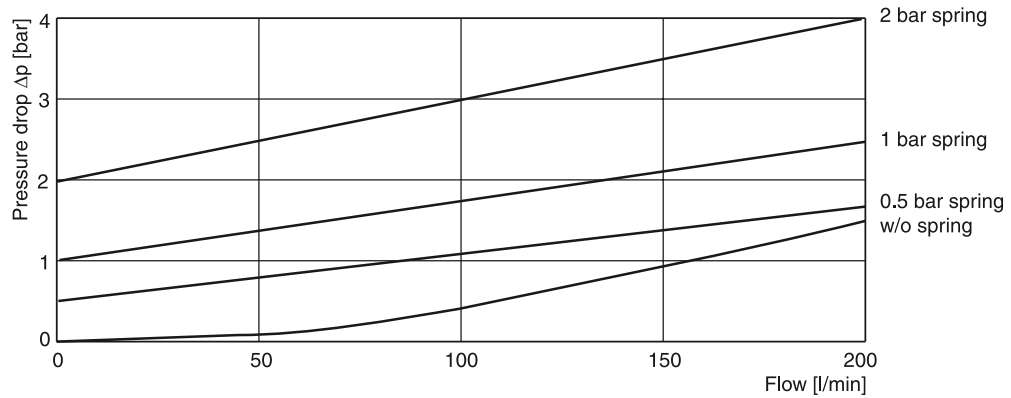

C5V10

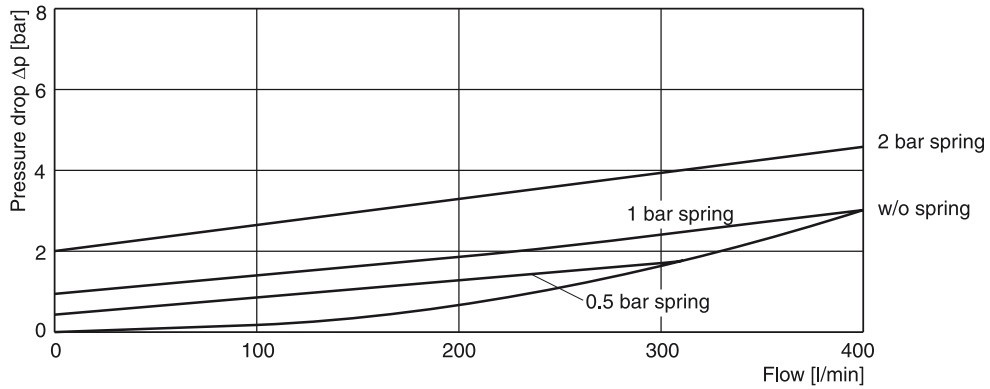

C5V12

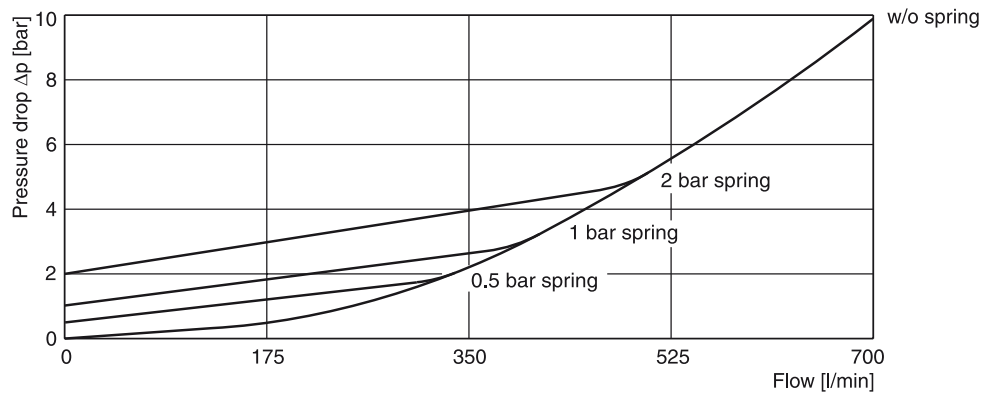

All characteristic curves measured with HLP46 at 50°C.

Characteristics C5V

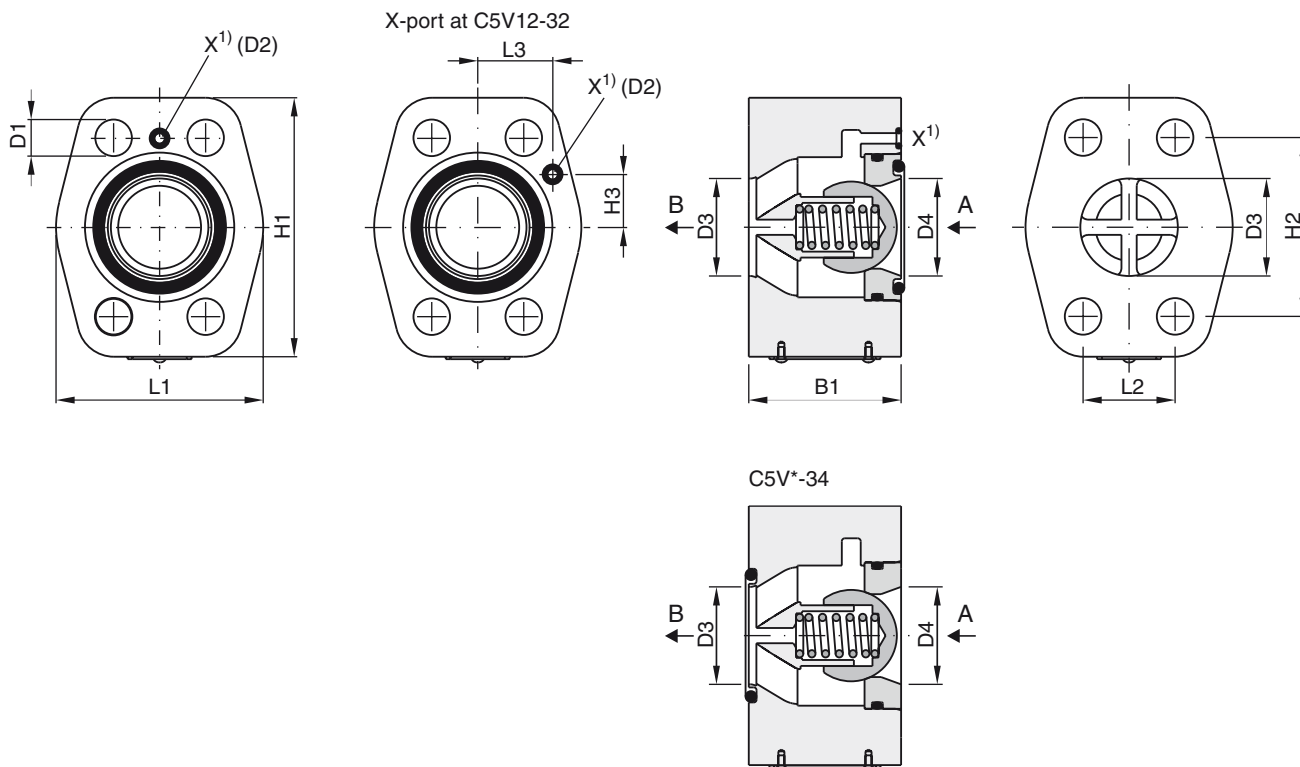

Position of O-ring seal according to ordering code.

1) X1 port for C5V\*32\* (for use with unloading valve R5U)

| Series | Nominal Size |       | L1 | L2   | L3   | H1  | H2   | H3   | B1 | D1                 | D2 | D3 + 0.8 | D4 |
|--------|--------------|-------|----|------|------|-----|------|------|----|--------------------|----|----------|----|
| C5V06  | 3/4          | SAE61 | 48 | 22.2 | 27.2 | 64  | 47.6 | 22.4 | 45 | 10.5               | Ø3 | 19       | 19 |
|        |              | SAE62 | 48 | 23.8 | 27.2 | 64  | 50.8 | 22.4 | 45 | 10.5               |    | 19       | 19 |
| C5V08  | 1            | SAE61 | 60 | 26.2 | 27.2 | 74  | 52.4 | 22.4 | 45 | 10.5               | Ø3 | 25       | 25 |
|        |              | SAE62 | 60 | 27.8 | 27.2 | 74  | 57.2 | 22.4 | 45 | 12.5               |    | 25       | 25 |
| C5V10  | 1 1/4        | SAE61 | 68 | 30.2 | 27.2 | 85  | 58.7 | 22.4 | 50 | 12.5               | Ø3 | 32       | 32 |
|        |              | SAE62 | 68 | 31.8 | 27.2 | 85  | 66.7 | 22.4 | 50 | 13.5 <sup>2)</sup> |    | 32       | 32 |
| C5V12  | 1 1/2        | SAE61 | 80 | 35.7 | 27.2 | 104 | 69.8 | 22.4 | 50 | 13.5               | Ø3 | 42       | 38 |
|        |              | SAE62 | 80 | 36.5 | 27.2 | 104 | 79.4 | 22.4 | 50 | 17.0               |    | 42       | 38 |

2) D1 = 15 at option code 019 for M14 mounting screws

| Seal kits |             |             |
|-----------|-------------|-------------|
| NG        | NBR         | FKM         |
| 06        | S26-75409-0 | S26-75409-5 |
| 08        | S26-75410-0 | S26-75410-5 |
| 10        | S26-75411-0 | S26-75411-5 |
| 12        | S26-75412-0 | S26-75412-5 |



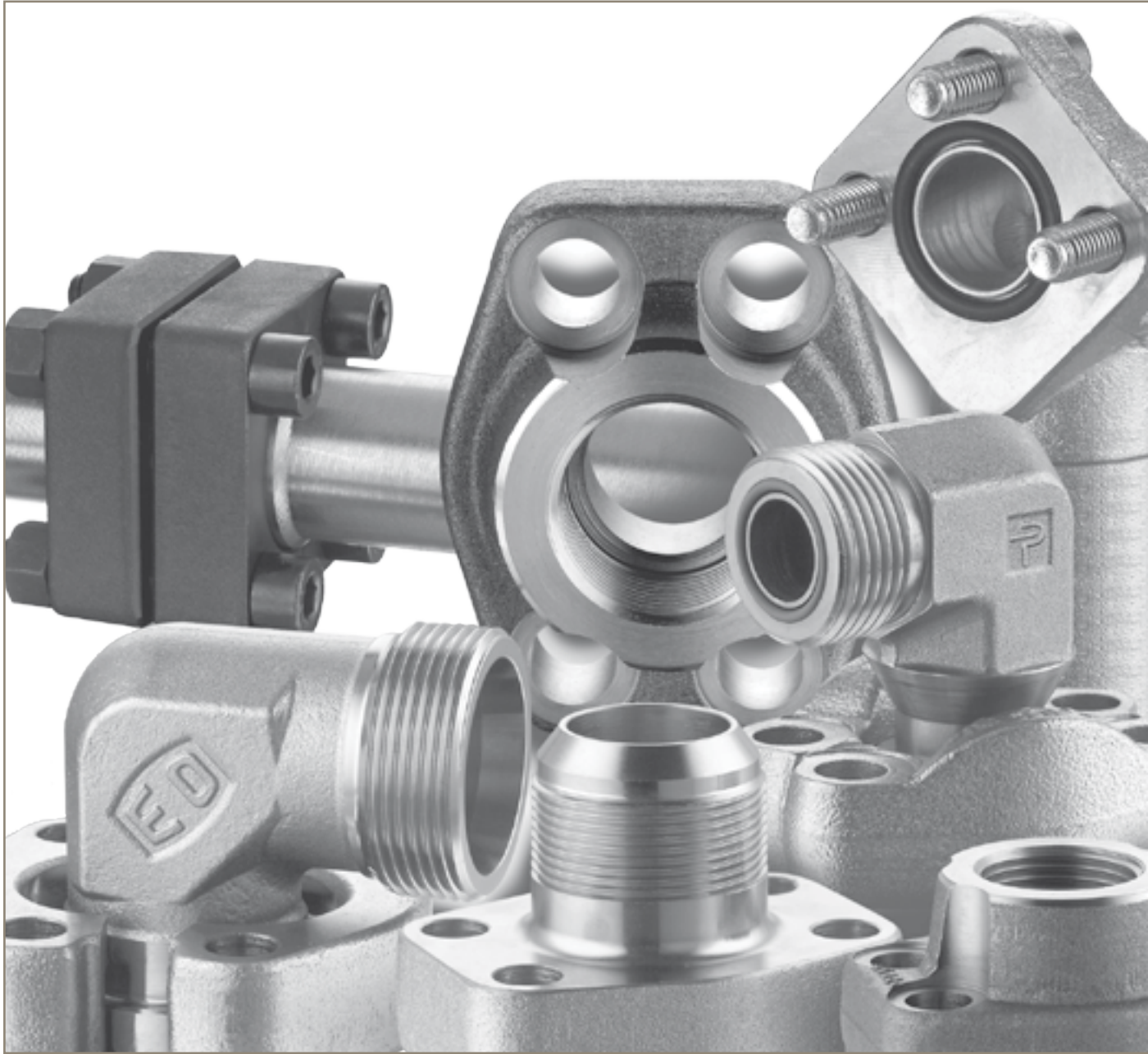

## SAE Flange adapters

ENGINEERING YOUR SUCCESS.

### Technical data

#### Flange bolts

##### SAE Flanges according to ISO 6162-1 and -2 (SAE J518)

- metric bolts according to  
DIN 912-8.8 (ISO 4762-8.8) or  
DIN 912-10.9 (ISO 4762-10.9)<sup>1</sup>
- UNC bolts according to ASA B 18.3

<sup>1</sup> Bolts with grade 10.9/12.9 are to be used, when the material for the flanges is high tempered!

#### Used Sealing

##### Materials

Flanges according **SAE J518 (ISO 6162-1 and -2)** are sealed with an O-Ring. The seals of our flanges are out of the following materials:

- NBR 90 durometer is our standard seal material for hydraulic **steel** flange applications.
- FKM 85 or 90 durometer is our standard seal material for hydraulic **stainless steel** flange applications.

##### Dimensions

For all flanges according to **SAE J518 (ISO 6162-1 and -2)** the O-Ring dimension are according to the following table:

| Nominal flange size | Nominal inch tube size (in inches) | ISO 3601-1 O-Ring | SAE J515 O-Ring | SAE J515 O-Ring size number |
|---------------------|------------------------------------|-------------------|-----------------|-----------------------------|
| 13                  | 1/2                                | 19×3.55           | 18.64×3.53      | 210                         |
| 19                  | 3/4                                | 25×3.55           | 24.99×3.53      | 214                         |
| 25                  | 1                                  | 32.5×3.55         | 32.92×3.53      | 219                         |
| 32                  | 1 1/4                              | 37.5×3.55         | 37.69×3.53      | 222                         |
| 38                  | 1 1/2                              | 47.5×3.55         | 47.22×3.53      | 225                         |
| 51                  | 2                                  | 56×3.55           | 56.74×3.53      | 228                         |
| 64                  | 2 1/2                              | 69×3.55           | 69.44×3.53      | 232                         |
| 76                  | 3                                  | 85×3.55           | 85.32×3.53      | 237                         |
| 89                  | 3 1/2                              | 97.5×3.55         | 98.02×3.53      | 241                         |
| 102                 | 4                                  | 112×3.55          | 110.72×3.53     | 245                         |
| 127                 | 5                                  | 136×3.55          | 136.12×3.53     | 253                         |

#### Pressure ratings

The maximum recommended working pressure is indicated for each article.

Before using a part, please take notice of the pressure ratings. All pressure indications are based on a working temperature from -20° celsius up to +100° celsius (resp. ambient temperature from -40° celsius up to +120° celsius). Outside of this temperature range the physical properties of the material is affected and the maximum recommended working pressure is reduced.

The indicated working pressures refer only to the flange itself. For the tubes, fittings and connections the pressure ratings of the specific manufacturer must also be taken into account.

#### Materials

##### SAE flanges according to ISO 6162-1 and -2 (SAE 518)

Flange clamps, flange adapter and forged 4 bolt flanges are made of the material ST 52.3 or compatible for **steel** construction. For **stainless steel** constructions we are using for flange clamps, flange adapters and 4 bolt forged flanges the material 1.4401 (316) or compatible. For special applications it is also possible to get the flange adapters made from the material 1.4571 (316Ti).

If different materials are used for manufacturing, this will be shown on the catalogue product page.

#### Surface protection

All surface order possibilities are described on each catalogue page!

Surface possibilities are:

1. Oil dipped
2. silver surface protection type A3K according to DIN EN ISO 4042
3. Cr(VI)-free surface protection type CF with better corrosion resistance than A3C surface protection

## Order codes bolts and O-Rings

### Bolts for flanges

according ISO 6162-1 and -2 (SAE J518)

| Nominal flange size |     |       | Bolts for flange halves |                   | Bolts for full flanges |                 |
|---------------------|-----|-------|-------------------------|-------------------|------------------------|-----------------|
| Series              | ISO | SAE   | metr. Order code        | UNC Order code    | metr. Order code       | UNC Order code  |
| 3000 PSI            | 13  | 1/2   | ZYLS8X25VZX             | UNC5/16-18X11/4   | ZYLS8X30VZX            | UNC5/16-18X11/4 |
| 3000 PSI            | 19  | 3/4   | ZYLS10X30VZX            | UNC3/8-16X11/4    | ZYLS10X35VZX           | UNC3/8-16X11/2  |
| 3000 PSI            | 25  | 1     | ZYLS10X30VZX            | UNC3/8-16X11/4    | ZYLS10X35VZX           | UNC3/8-16X11/2  |
| 3000 PSI            | 32  | 1 1/4 | ZYLS10X30VZX            | UNC7/16-14X11/2   | ZYLS10X40VZX           | UNC7/16-14X11/2 |
| 3000 PSI            | 32  | 1 1/4 | ZYLS10X35VZX *          |                   |                        |                 |
| 3000 PSI            | 32  | 1 1/4 | ZYLS12X35VZX *          |                   |                        |                 |
| 3000 PSI            | 38  | 1 1/2 | ZYLS12X35VZX            | UNC1/2-13X11/2    | ZYLS12X45VZX           | UNC1/2-13X13/4  |
| 3000 PSI            | 38  | 1 1/2 | ZYLS14X35VZX *          |                   |                        |                 |
| 3000 PSI            | 51  | 2     | ZYLS12X35VZX            | UNC1/2-13X11/2    | ZYLS12X45VZX           | UNC1/2-13X13/4  |
| 3000 PSI            | 51  | 2     | ZYLS14X35VZX *          |                   |                        |                 |
| 3000 PSI            | 64  | 2 1/2 | ZYLS12X40VZX            | UNC1/2-13X11/2 *  | ZYLS12X45VZX           | UNC1/2-13X13/4  |
| 3000 PSI            | 64  | 2 1/2 | ZYLS14X35VZX *          | UNC1/2-13X13/4    |                        |                 |
| 3000 PSI            | 76  | 3     | ZYLS16X50VZX            | UNC5/8-11X2 *     | ZYLS16X55VZX           | UNC5/8-11X21X4  |
| 3000 PSI            | 76  | 3     | ZYLS16X45VZX *          | UNC5/8-11X13/4    |                        |                 |
| 3000 PSI            | 89  | 3 1/2 | ZYLS16X50VZX            | UNC5/8-11X2 *     | ZYLS16X55VZX           | UNC5/8-11X21X4  |
| 3000 PSI            | 89  | 3 1/2 | ZYLS16X45VZX *          |                   |                        |                 |
| 3000 PSI            | 102 | 4     | ZYLS16X50VZX            | UNC5/8-11X2       | ZYLS16X55VZX           | UNC5/8-11X21X4  |
| 3000 PSI            | 102 | 4     | ZYLS16X45VZX *          |                   |                        |                 |
| 3000 PSI            | 127 | 5     | ZYLS16X50VZX *          | UNC5/8-11X21/4    | ZYLS16X55VZX           | UNC5/8-11X21X4  |
| 3000 PSI            | 127 | 5     | ZYLS16X55VZX            | UNC5/8-11X2 *     |                        |                 |
| Series              | ISO | SAE   | metr.                   | UNC               | metr.                  | UNC             |
| 6000 PSI            | 13  | 1/2   | ZYLS8X30VZX             | UNC5/16-18X11/4   | ZYLS8X30VZX            | UNC5/16-18X11/4 |
| 6000 PSI            | 19  | 3/4   | ZYLS10X35VZX            | UNC3/8-16X11/2    | ZYLS10X35VZX           | UNC3/8-16X11/2  |
| 6000 PSI            | 25  | 1     | ZYLS12X45VZX            | UNC7/16-14X11/2 * | ZYLS12X45VZX           | UNC7/16-14X11/2 |
| 6000 PSI            | 25  | 1     |                         | UNC7/16-14X13/4   |                        |                 |
| 6000 PSI            | 32  | 1 1/4 | ZYLS14X50VZX *          | UNC1/2-13X13/4    | ZYLS14X50VZX           | UNC1/2-13X13/4  |
| 6000 PSI            | 32  | 1 1/4 | ZYLS12X45VZX            |                   |                        |                 |
| 6000 PSI            | 38  | 1 1/2 | ZYLS16X55VZX            | UNC5/8-11X21/4    | ZYLS16X55VZX           | UNC5/8-11X21X4  |
| 6000 PSI            | 38  | 1 1/2 |                         | UNC5/8-11X2 *     |                        |                 |
| 6000 PSI            | 51  | 2     | ZYLS20X65VZX *          | UNC3/4-10X23/4    | ZYLS20X70VZX           | UNC3/4-10X23X4  |
| 6000 PSI            | 51  | 2     | ZYLS20X70VZ             | UNC3/4-10X21/2 *  |                        |                 |
| 6000 PSI            | 64  | 2 1/2 | ZYLS24X75VZX            |                   | ZYLS24X90VZX           |                 |
| 6000 PSI            | 76  | 3     | ZYLS30X90VZX            |                   | ZYLS30X110VZX          |                 |

\* = are not implemented in the ISO 6162 -1 and ISO 6162-2.

### O-Rings for flanges

SAE J518

| ISO (DN) | SAE (Inch) | O-Ring         |                   |
|----------|------------|----------------|-------------------|
|          |            | NBR Order code | FKM Order code    |
| 13       | 1/2        | OR18.64X3.53X  | OR18.64X3.53VITX  |
| 19       | 3/4        | OR25X3.53X     | OR25X3.53VITX     |
| 25       | 1          | OR32.92X3.53X  | OR32.92X3.53VITX  |
| 32       | 1 1/4      | OR37.69X3.53X  | OR37.69X3.53VITX  |
| 38       | 1 1/2      | OR47.22X3.53X  | OR47.22X3.53VITX  |
| 51       | 2          | OR56.75X3.53X  | OR56.75X3.53VITX  |
| 64       | 2 1/2      | OR69.44X3.53X  | OR69.44X3.53VITX  |
| 76       | 3          | OR85.32X3.53X  | OR85.32X3.53VITX  |
| 89       | 3 1/2      | OR98.02X3.53X  | OR98.02X3.53VITX  |
| 102      | 4          | OR110.72X3.53X | OR110.72X3.53VITX |
| 127      | 5          | OR136.12X3.53X | OR136.12X3.53VITX |

Programme overview

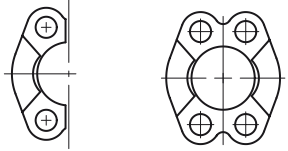
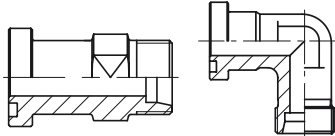
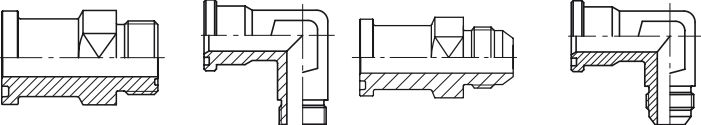
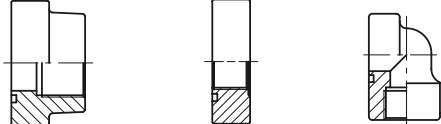
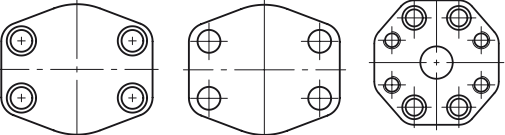
|                                   |  |
|-----------------------------------|--|
| <p>SAE<br/>Flange clamps</p>      |  <p><b>FHS</b> – p.205      <b>FUS</b> – p.206</p>  |
| <p>SAE<br/>Flange adapters</p>    | <p><b>EO 24° cone end</b></p>  <p><b>GFS</b> – p.207/208      <b>WFS</b> – p.209/210</p>  |
| <p>SAE<br/>4 Bolt flanges</p>     | <p><b>O-Lok® ORFS end</b>      <b>Triple-Lok® 37° flare end</b></p>  <p><b>L(O)HQ</b> – p.211      <b>L(O)EMQ</b> – p.210      <b>XHQ</b> – p.213      <b>XEMQ</b> – p.214</p> |
| <p>SAE<br/>Flange accessories</p> | <p><b>BSPP Female thread</b></p>  <p><b>PFF-G</b> – p.215      <b>PAFSF-G</b> – p.216      <b>PEFF-G</b> – p.217</p>  |
| <p>SAE<br/>Flange accessories</p> |  <p><b>PCFF</b> – p.218      <b>AP</b> – p.219      <b>PRF</b> – p.220</p>  |

**FHS – SAE Split flange halves**

SAE 3000/6000  
ISO 6162-1/-2

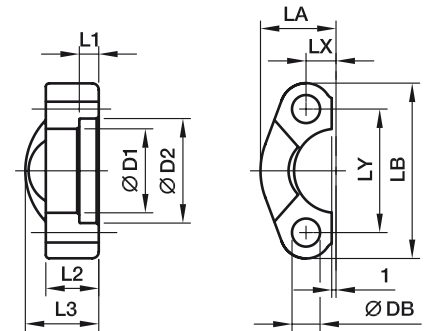

**SAE 3000**

| Nom. flange size |          | D1    | D2    | L1   | L2 | L3 | LA   | LB    | LX   | LY    | DB   | Bolts   |            | Weight (steel)<br>kg/1 piece | Order code       | W.P. |
|------------------|----------|-------|-------|------|----|----|------|-------|------|-------|------|---------|------------|------------------------------|------------------|------|
| SAE (in)         | ISO (DN) |       |       |      |    |    |      |       |      |       |      | (metr.) | (unc.)     |                              |                  |      |
| 1/2              | 13       | 24.3  | 31.0  | 6.2  | 13 | 19 | 23.0 | 54.0  | 8.7  | 38.1  | 9.0  | M 8×25  | 5/16×1 1/4 | 0.07                         | <b>FHS32</b>     | 345  |
| 3/4              | 19       | 32.2  | 38.9  | 6.2  | 14 | 22 | 25.9 | 65.0  | 11.1 | 47.6  | 11.0 | M10×30  | 3/8×1 1/4  | 0.09                         | <b>FHS33</b>     | 345  |
| 1                | 25       | 38.5  | 45.2  | 7.5  | 16 | 24 | 29.2 | 69.9  | 13.1 | 52.4  | 11.0 | M10×30  | 3/8×1 1/4  | 0.11                         | <b>FHS34</b>     | 345  |
| 1 1/4            | 32       | 43.7  | 51.6  | 7.5  | 16 | 22 | 36.3 | 79.4  | 15.1 | 58.7  | 11.0 | M10×35  |            | 0.15                         | <b>FHS35/10</b>  | 276  |
| 1 1/4            | 32       | 43.7  | 51.6  | 7.5  | 16 | 22 | 36.3 | 79.4  | 15.1 | 58.7  | 12.0 |         | 7/16×1 1/2 | 0.15                         | <b>FHS35/12</b>  | 276  |
| 1 1/4            | 32       | 43.7  | 51.6  | 7.5  | 16 | 22 | 36.3 | 79.4  | 15.1 | 58.7  | 12.5 | M12×35  |            | 0.15                         | <b>FHS35</b>     | 276  |
| 1 1/2            | 38       | 50.8  | 61.1  | 7.5  | 16 | 25 | 41.1 | 93.8  | 17.9 | 69.9  | 13.0 | M12×35  | 1/2×1 1/2  | 0.23                         | <b>FHS36</b>     | 207  |
| 1 1/2            | 38       | 50.8  | 61.1  | 7.5  | 16 | 25 | 41.1 | 93.8  | 17.9 | 69.9  | 14.5 | M14×35  |            | 0.23                         | <b>FHS36/14</b>  | 207  |
| 2                | 51       | 62.8  | 72.3  | 9.0  | 16 | 26 | 48.2 | 101.6 | 21.4 | 77.8  | 13.0 | M12×35  | 1/2×1 1/2  | 0.25                         | <b>FHS38/12</b>  | 207  |
| 2                | 51       | 62.8  | 72.3  | 9.0  | 16 | 26 | 48.2 | 101.6 | 21.4 | 77.8  | 14.5 | M14×35  |            | 0.25                         | <b>FHS38</b>     | 207  |
| 2 1/2            | 64       | 74.9  | 84.9  | 9.0  | 19 | 38 | 54.1 | 114.3 | 25.4 | 88.9  | 13.0 | M12×40  | 1/2×1 3/4  | 0.37                         | <b>FHS310</b>    | 172  |
| 2 1/2            | 64       | 74.9  | 84.9  | 9.0  | 19 | 38 | 54.1 | 114.3 | 25.4 | 88.9  | 14.5 | M14×40  |            | 0.37                         | <b>FHS310/14</b> | 172  |
| 3                | 76       | 90.9  | 102.4 | 9.0  | 22 | 41 | 65.3 | 135.0 | 31.0 | 106.4 | 17.0 | M16×45  | 5/8×1 3/4  | 0.65                         | <b>FHS312</b>    | 138  |
| 3 1/2            | 89       | 102.4 | 115.1 | 10.7 | 22 | 28 | 68.6 | 152.4 | 35.0 | 120.7 | 17.0 | M16×45  | 5/8×2      | 0.75                         | <b>FHS314</b>    | 34   |
| 4                | 102      | 115.1 | 127.8 | 10.7 | 25 | 35 | 74.9 | 162.0 | 39.0 | 130.2 | 17.0 | M16×50  | 5/8×2      | 0.84                         | <b>FHS316</b>    | 34   |
| 5                | 127      | 140.5 | 153.2 | 10.7 | 28 | 41 | 89.4 | 184.2 | 46.0 | 152.4 | 17.0 | M16×50  | 5/8×2 1/4  | 1.25                         | <b>FHS320</b>    | 34   |

**SAE 6000**

|       |    |       |       |      |    |    |      |       |      |       |      |        |            |      |                 |     |
|-------|----|-------|-------|------|----|----|------|-------|------|-------|------|--------|------------|------|-----------------|-----|
| 1/2   | 13 | 24.6  | 32.5  | 7.2  | 16 | 22 | 24.0 | 56.4  | 9.1  | 40.5  | 9.0  | M 8×30 | 5/16×1 1/4 | 0.08 | <b>FHS62</b>    | 420 |
| 3/4   | 19 | 32.5  | 42.0  | 8.2  | 19 | 28 | 30.0 | 71.4  | 11.9 | 50.8  | 11.0 | M10×35 | 3/8×1 1/2  | 0.18 | <b>FHS63</b>    | 420 |
| 1     | 25 | 38.8  | 48.4  | 9.0  | 24 | 33 | 34.8 | 81.0  | 13.9 | 57.2  | 13.0 | M12×45 |            | 0.27 | <b>FHS64</b>    | 420 |
| 1     | 25 | 38.9  | 48.4  | 9.0  | 24 | 33 | 34.8 | 81.0  | 13.9 | 57.2  | 12.0 |        | 7/16×1 3/4 | 0.27 | <b>FHS64/12</b> | 420 |
| 1 1/4 | 32 | 44.5  | 54.8  | 9.8  | 27 | 38 | 38.6 | 95.3  | 15.9 | 66.6  | 15.0 | M14×50 |            | 0.40 | <b>FHS65</b>    | 420 |
| 1 1/4 | 32 | 44.5  | 54.8  | 9.8  | 27 | 38 | 38.6 | 95.3  | 15.9 | 66.6  | 13.0 | M12×45 | 1/2×1 3/4  | 0.40 | <b>FHS65/12</b> | 420 |
| 1 1/2 | 38 | 51.6  | 64.3  | 12.1 | 30 | 43 | 47.5 | 112.8 | 18.3 | 79.3  | 17.0 | M16×55 | 5/8×2 1/4  | 0.68 | <b>FHS66</b>    | 420 |
| 2     | 51 | 67.6  | 80.2  | 12.1 | 37 | 52 | 56.9 | 133.4 | 22.2 | 96.8  | 22.0 | M20×65 | 3/4×2 3/4  | 1.05 | <b>FHS68</b>    | 420 |
| 2 1/2 | 64 | 90.0  | 108.9 | 20.5 | 45 | 45 | 75.1 | 180.0 | 29.4 | 123.8 | 25.0 | M24×75 |            | 1.96 | <b>FHS610</b>   | 420 |
| 3     | 76 | 115.0 | 132.5 | 25.5 | 55 | 55 | 99.1 | 215.0 | 35.8 | 152.4 | 31.5 | M30×90 |            | 3.37 | <b>FHS612</b>   | 420 |

Please change suffixes according to material/surface required

| Order code suffixes             |                             |          |                  |
|---------------------------------|-----------------------------|----------|------------------|
| Material                        | Suffix surface and material | Example  | Description      |
| Steel, zinc plated, Cr(VI)-free | CF                          | FHS32CFX | only flange half |
| Stainless steel                 | SS                          | FHS32SS  | only flange half |



## SAE Flange adapters

### FUS – SAE Flange clamps

SAE 3000/6000  
ISO 6162-1/-2

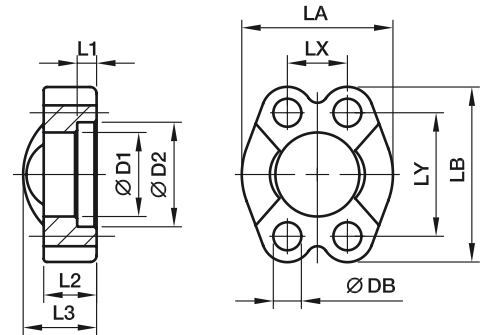

#### SAE 3000

| Nom. flange size |             |       |       |      |    |    |     |       |      |       |      | Bolts   |            | Weight<br>(steel)<br>kg/1 piece | Order code       | W.P. |
|------------------|-------------|-------|-------|------|----|----|-----|-------|------|-------|------|---------|------------|---------------------------------|------------------|------|
| SAE<br>(in)      | ISO<br>(DN) | D1    | D2    | L1   | L2 | L3 | LA  | LB    | LX   | LY    | DB   | (metr.) | (unc.)     |                                 |                  |      |
| 1/2              | 13          | 24.3  | 31.0  | 6.2  | 13 | 19 | 46  | 54.0  | 17.5 | 38.1  | 9.0  | M 8×25  | 5/16×1 1/4 | 0.15                            | <b>FUS32</b>     | 345  |
| 3/4              | 19          | 32.2  | 38.9  | 6.2  | 14 | 22 | 52  | 65.0  | 22.3 | 47.6  | 11.0 | M10×30  | 3/8×1 1/4  | 0.17                            | <b>FUS33</b>     | 345  |
| 1                | 25          | 38.5  | 45.2  | 7.5  | 16 | 24 | 59  | 69.9  | 26.2 | 52.4  | 11.0 | M10×30  | 3/8×1 1/4  | 0.22                            | <b>FUS34</b>     | 345  |
| 1 1/4            | 32          | 43.7  | 51.6  | 7.5  | 16 | 22 | 73  | 79.4  | 30.2 | 58.7  | 11.0 | M10×35  |            | 0.30                            | <b>FUS35/10</b>  | 276  |
| 1 1/4            | 32          | 43.7  | 51.6  | 7.5  | 16 | 22 | 73  | 79.4  | 30.2 | 58.7  | 12.0 |         | 7/16×1 1/2 | 0.29                            | <b>FUS35/12</b>  | 276  |
| 1 1/4            | 32          | 43.7  | 51.6  | 7.5  | 16 | 22 | 73  | 79.4  | 30.2 | 58.7  | 12.5 | M12×35  |            | 0.29                            | <b>FUS35</b>     | 276  |
| 1 1/2            | 38          | 50.8  | 61.1  | 7.5  | 16 | 25 | 83  | 93.8  | 35.7 | 69.9  | 13.0 | M12×35  | 1/2×1 1/2  | 0.45                            | <b>FUS36</b>     | 207  |
| 1 1/2            | 38          | 50.8  | 61.1  | 7.5  | 16 | 25 | 83  | 93.8  | 35.7 | 69.9  | 14.5 | M14×35  |            | 0.44                            | <b>FUS36/14</b>  | 207  |
| 2                | 51          | 62.8  | 72.3  | 9.0  | 16 | 26 | 97  | 101.6 | 42.9 | 77.8  | 13.0 | M12×35  | 1/2×1 1/2  | 0.50                            | <b>FUS38/12</b>  | 207  |
| 2                | 51          | 62.8  | 72.3  | 9.0  | 16 | 26 | 97  | 101.6 | 42.9 | 77.8  | 14.5 | M14×35  |            | 0.49                            | <b>FUS38</b>     | 207  |
| 2 1/2            | 64          | 74.9  | 84.9  | 9.0  | 19 | 38 | 109 | 114.3 | 50.8 | 88.9  | 13.0 | M12×40  | 1/2×1 3/4  | 0.74                            | <b>FUS310</b>    | 172  |
| 2 1/2            | 64          | 74.9  | 84.9  | 9.0  | 19 | 38 | 109 | 114.3 | 50.8 | 88.9  | 14.5 | M14×40  |            | 0.73                            | <b>FUS310/14</b> | 172  |
| 3                | 76          | 90.9  | 102.4 | 9.0  | 22 | 41 | 131 | 135.0 | 61.9 | 106.4 | 17.0 | M16×45  | 5/8×1 3/4  | 1.30                            | <b>FUS312</b>    | 138  |
| 3 1/2            | 89          | 102.4 | 115.1 | 10.7 | 22 | 28 | 140 | 152.4 | 69.9 | 120.7 | 17.0 | M16×45  | 5/8×2      | 1.50                            | <b>FUS314</b>    | 34   |
| 4                | 102         | 115.1 | 127.8 | 10.7 | 25 | 35 | 150 | 162.0 | 77.8 | 130.2 | 17.0 | M16×50  | 5/8×2      | 1.65                            | <b>FUS316</b>    | 34   |
| 5                | 127         | 140.5 | 153.2 | 10.7 | 28 | 41 | 180 | 184.2 | 92.1 | 152.4 | 17.0 | M16×50  | 5/8×2 1/4  | 2.50                            | <b>FUS320</b>    | 34   |

#### SAE 6000

|       |    |       |       |      |    |    |     |       |      |       |      |        |            |      |                 |     |
|-------|----|-------|-------|------|----|----|-----|-------|------|-------|------|--------|------------|------|-----------------|-----|
| 1/2   | 13 | 24.6  | 32.5  | 7.2  | 16 | 22 | 48  | 56.4  | 18.2 | 40.5  | 9.0  | M 8×30 | 5/16×1 1/4 | 0.16 | <b>FUS62</b>    | 420 |
| 3/4   | 19 | 32.5  | 42.0  | 8.2  | 19 | 28 | 60  | 71.4  | 23.8 | 50.8  | 11.0 | M10×35 | 3/8×1 1/2  | 0.35 | <b>FUS63</b>    | 420 |
| 1     | 25 | 38.8  | 48.4  | 9.0  | 24 | 33 | 70  | 81.0  | 27.8 | 57.2  | 13.0 | M12×45 |            | 0.53 | <b>FUS64</b>    | 420 |
| 1     | 25 | 38.9  | 48.4  | 9.0  | 24 | 33 | 70  | 81.0  | 27.8 | 57.2  | 12.0 |        | 7/16×1 3/4 | 0.53 | <b>FUS64/12</b> | 420 |
| 1 1/4 | 32 | 44.5  | 54.8  | 9.8  | 27 | 38 | 78  | 95.3  | 31.8 | 66.6  | 15.0 | M14×50 |            | 0.80 | <b>FUS65</b>    | 420 |
| 1 1/4 | 32 | 44.5  | 54.8  | 9.8  | 27 | 38 | 78  | 95.3  | 31.8 | 66.6  | 13.0 | M12×45 | 1/2×1 3/4  | 0.80 | <b>FUS65/12</b> | 420 |
| 1 1/2 | 38 | 51.6  | 64.3  | 12.1 | 30 | 43 | 96  | 112.8 | 36.5 | 79.3  | 17.0 | M16×55 | 5/8×2 1/4  | 1.35 | <b>FUS66</b>    | 420 |
| 2     | 51 | 67.6  | 80.2  | 12.1 | 37 | 52 | 114 | 133.4 | 44.5 | 96.8  | 22.0 | M20×65 | 3/4×2 3/4  | 2.10 | <b>FUS68</b>    | 420 |
| 2 1/2 | 64 | 90.0  | 108.9 | 20.5 | 45 | 45 | 150 | 180.0 | 58.7 | 123.8 | 25.0 | M24×75 |            | 4.10 | <b>FUS610</b>   | 420 |
| 3     | 76 | 115.0 | 132.5 | 25.5 | 55 | 55 | 178 | 215.0 | 71.4 | 152.4 | 31.5 | M30×90 |            | 8.60 | <b>FUS612</b>   | 420 |

Please change suffixes according to material/surface required

| Order code suffixes             |                             |          |                   |
|---------------------------------|-----------------------------|----------|-------------------|
| Material                        | Suffix surface and material | Example  | Description       |
| Steel, zinc plated, Cr(VI)-free | CF                          | FUS32CFX | only flange clamp |
| Stainless steel                 | SS                          | FUS32SS  | only flange clamp |





**GFS – SAE Straight flange adapter**

SAE Flange/EO 24° cone end  
(ISO 6162-1)

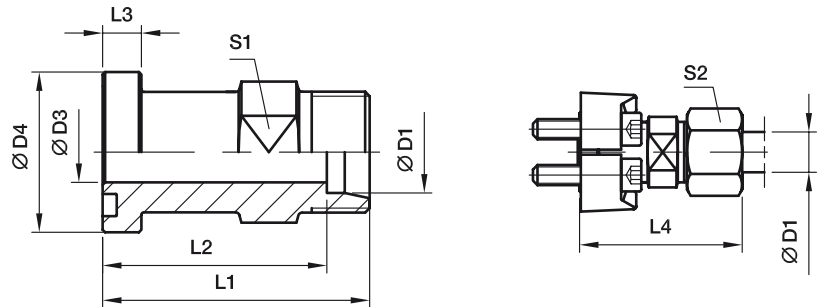

**SAE 3000**

| Nom. flange size |             | D1 <sup>1)</sup> |      |      |      |      |     |      |    |    | Bolts   |            | Weight<br>(steel)<br>kg/1 piece | Order code                       | W.P. |
|------------------|-------------|------------------|------|------|------|------|-----|------|----|----|---------|------------|---------------------------------|----------------------------------|------|
| SAE<br>(in)      | ISO<br>(DN) |                  | D3   | D4   | L1   | L2   | L3  | L4   | S1 | S2 | (metr.) | (unc.)     |                                 |                                  |      |
| 1/2              | 13          | 15L              | 12.0 | 30.2 | 48.0 | 41.0 | 6.7 | 56.0 | 24 | 27 | M 8×25  | 5/16×1 1/4 | 0.36                            | <b>GFS32/15L</b>                 | 315  |
| 1/2              | 13          | 16S              | 12.0 | 30.2 | 50.0 | 41.5 | 6.7 | 60.0 | 24 | 30 | M 8×25  | 5/16×1 1/4 | 0.40                            | <b>GFS32/16S</b>                 | 350  |
| 1/2              | 13          | 18L              | 14.0 | 30.2 | 50.0 | 42.5 | 6.7 | 61.0 | 19 | 32 | M 8×25  | 5/16×1 1/4 | 0.42                            | <b>GFS32/18L</b>                 | 315  |
| 3/4              | 19          | 16S              | 12.0 | 38.1 | 55.0 | 46.5 | 6.7 | 64.5 | 27 | 30 | M10×30  | 3/8×1 1/4  | 0.52                            | <b>GFS33/16S</b>                 | 350  |
| 3/4              | 19          | 18L              | 17.0 | 38.1 | 53.0 | 45.5 | 6.7 | 62.0 | 30 | 32 | M10×30  | 3/8×1 1/4  | 0.59                            | <b>GFS33/18L</b>                 | 315  |
| 3/4              | 19          | 22L              | 19.0 | 38.1 | 53.0 | 45.5 | 6.7 | 62.0 | 30 | 36 | M10×30  | 3/8×1 1/4  | 0.59                            | <b>GFS33/22L</b>                 | 160  |
| 3/4              | 19          | 28L              | 19.0 | 38.1 | 55.0 | 41.0 | 6.7 | 64.0 | 32 | 41 | M10×30  | 3/8×1 1/4  | 0.60                            | <b>GFS33/28L</b>                 | 160  |
| 3/4              | 19          | 20S              | 17.0 | 38.1 | 57.0 | 46.5 | 6.7 | 68.0 | 30 | 36 | M10×30  | 3/8×1 1/4  | 0.65                            | <b>GFS33/20S</b>                 | 350  |
| 3/4              | 19          | 25S              | 17.0 | 38.1 | 57.0 | 45.0 | 6.7 | 69.0 | 30 | 46 | M10×30  | 3/8×1 1/4  | 0.78                            | <b>GFS33/25S</b>                 | 350  |
| 1                | 25          | 20S              | 25.0 | 44.5 | 60.0 | 48.5 | 8.0 | 71.0 | 32 | 36 | M10×30  | 3/8×1 1/4  | 0.70                            | <b>GFS34/20S</b>                 | 350  |
| 1                | 25          | 28L              | 24.0 | 44.5 | 54.0 | 46.5 | 8.0 | 63.0 | 36 | 41 | M10×30  | 3/8×1 1/4  | 0.73                            | <b>GFS34/28L</b>                 | 160  |
| 1                | 25          | 25S              | 20.0 | 44.5 | 58.0 | 46.5 | 8.0 | 60.0 | 36 | 46 | M10×30  | 3/8×1 1/4  | 0.84                            | <b>GFS34/25S</b>                 | 350  |
| 1                | 25          | 30S              | 24.0 | 44.5 | 63.0 | 49.5 | 8.0 | 76.0 | 36 | 50 | M10×30  | 3/8×1 1/4  | 0.94                            | <b>GFS34/30S</b>                 | 250  |
| 1                | 25          | 42L              | 24.0 | 44.5 | 76.0 | 65.0 | 8.0 | 87.5 | 41 | 60 | M10×30  | 3/8×1 1/4  | 0.95                            | <b>GFS34/42L</b>                 | 160  |
| 1 1/4            | 32          | 35L              | 32.0 | 50.8 | 58.0 | 47.5 | 8.0 | 69.0 | 41 | 50 | M10×35  |            | 0.96                            | <b>GFS35/35L/10<sup>2)</sup></b> | 160  |
| 1 1/4            | 32          | 25S              | 27.0 | 50.8 | 60.0 | 48.0 | 8.0 | 72.0 | 41 | 46 | M10×35  |            | 1.11                            | <b>GFS35/25S/10</b>              | 200  |
| 1 1/4            | 32          | 30S              | 28.5 | 50.8 | 62.0 | 48.5 | 8.0 | 75.0 | 41 | 50 | M10×35  |            | 1.13                            | <b>GFS35/30S/10</b>              | 200  |
| 1 1/4            | 32          | 38S              | 28.0 | 50.8 | 66.0 | 50.0 | 8.0 | 81.0 | 46 | 60 | M10×35  |            | 1.36                            | <b>GFS35/38S/10</b>              | 200  |
| 1 1/4            | 32          | 28L              | 23.0 | 50.8 | 60.0 | 52.5 | 8.0 | 67.0 | 36 | 41 | M12×40  | 7/16×1 1/2 | 1.12                            | <b>GFS35/28L</b>                 | 160  |
| 1 1/4            | 32          | 35L              | 32.0 | 50.8 | 58.0 | 47.5 | 8.0 | 69.0 | 41 | 50 | M12×40  | 7/16×1 1/2 | 1.02                            | <b>GFS35/35L</b>                 | 160  |
| 1 1/4            | 32          | 25S              | 27.0 | 50.8 | 60.0 | 48.0 | 8.0 | 72.0 | 41 | 46 | M12×40  | 7/16×1 1/2 | 1.17                            | <b>GFS35/25S</b>                 | 200  |
| 1 1/4            | 32          | 30S              | 28.5 | 50.8 | 62.0 | 48.5 | 8.0 | 75.0 | 41 | 50 | M12×40  | 7/16×1 1/2 | 1.20                            | <b>GFS35/30S</b>                 | 200  |
| 1 1/4            | 32          | 38S              | 28.0 | 50.8 | 66.0 | 50.0 | 8.0 | 81.0 | 46 | 60 | M12×40  | 7/16×1 1/2 | 1.41                            | <b>GFS35/38S</b>                 | 200  |
| 1 1/2            | 38          | 35L              | 30.0 | 60.3 | 65.0 | 54.5 | 8.0 | 76.0 | 46 | 50 | M12×35  | 1/2×1 1/2  | 1.20                            | <b>GFS36/35L</b>                 | 160  |
| 1 1/2            | 38          | 42L              | 36.0 | 60.3 | 64.0 | 53.0 | 8.0 | 76.0 | 46 | 60 | M12×35  | 1/2×1 1/2  | 1.36                            | <b>GFS36/42L</b>                 | 160  |
| 1 1/2            | 38          | 38S              | 32.0 | 60.3 | 70.0 | 54.0 | 8.0 | 85.0 | 46 | 60 | M12×35  | 1/2×1 1/2  | 1.63                            | <b>GFS36/38S</b>                 | 200  |

<sup>1)</sup>L = light series; S = heavy series

**Delivery without nut and ring.**

**For nuts and cutting rings see also**

**Industrial Tube Fittings Europe Catalogue 4100.**

<sup>2)</sup>Order code for the flange adapter assembled with FHS35/10CFX and M10X35 bolts.

Please change suffixes according to material/surface required

| Order code suffixes             |                             |                             |  |  |   |
|---------------------------------|-----------------------------|-----------------------------|--|--|---|
| Material                        | Suffix surface and material | Example only flange adapter | Example incl. splitflanges, metr. bolts and O-Ring | Example incl. splitflanges, UNC bolts and O-Ring | Standard sealing material (no additional suffix needed) |
| Steel, zinc plated, Cr(VI)-free | CF                          | GFS32/16SCFX                | GFS32/16SOMDCF                                     | GFS32/16SOMDCFU                                  | NBR   |
| Stainless steel                 | 71                          | GFS32/16S71X                | GFS32/16SOMD71                                     | GFS32/16SOMD71U                                  | VIT   |

## SAE Flange adapters

### GFS – SAE Straight flange adapter

SAE Flange/EO 24° cone end  
(ISO 6162-2)

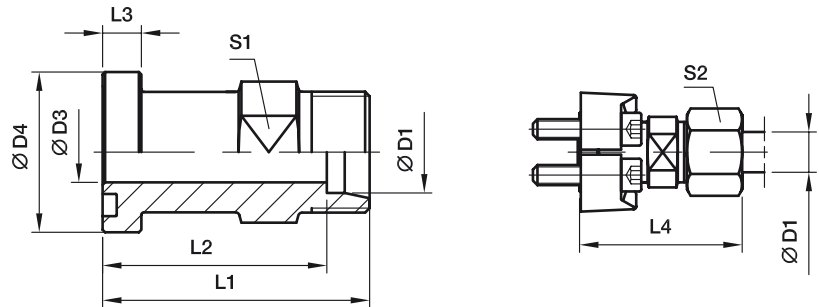

#### SAE 6000

| Nom. flange size |             | D1 <sup>1)</sup> |    |      |      |      |      |       |    |    | Bolts   |            | Weight<br>(steel)<br>kg/1 piece | Order code                       | W.P.<br>CF |
|------------------|-------------|------------------|----|------|------|------|------|-------|----|----|---------|------------|---------------------------------|----------------------------------|------------|
| SAE<br>(in)      | ISO<br>(DN) |                  | D3 | D4   | L1   | L2   | L3   | L4    | S1 | S2 | (metr.) | (unc.)     |                                 |                                  |            |
| 1/2              | 13          | 12S              | 8  | 31.8 | 50.0 | 42.5 | 7.7  | 57.5  | 19 | 24 | M 8x30  | 5/16x1 1/4 | 0.35                            | <b>GFS62/12S</b>                 | 420        |
| 1/2              | 13          | 14S              | 10 | 31.8 | 50.0 | 42.0 | 7.7  | 59.5  | 19 | 27 | M 8x30  | 5/16x1 1/4 | 0.39                            | <b>GFS62/14S</b>                 | 420        |
| 1/2              | 13          | 16S              | 12 | 31.8 | 53.0 | 44.5 | 7.7  | 62.5  | 24 | 30 | M 8x30  | 5/16x1 1/4 | 0.47                            | <b>GFS62/16S</b>                 | 420        |
| 3/4              | 19          | 16S              | 17 | 41.3 | 59.0 | 50.5 | 8.7  | 68.5  | 30 | 30 | M10x35  | 3/8x1 1/2  | 0.79                            | <b>GFS63/16S</b>                 | 420        |
| 3/4              | 19          | 20S              | 17 | 41.3 | 61.0 | 50.5 | 8.7  | 72.0  | 30 | 36 | M10x35  | 3/8x1 1/2  | 0.86                            | <b>GFS63/20S</b>                 | 420        |
| 3/4              | 19          | 25S              | 17 | 41.3 | 63.0 | 51.0 | 8.7  | 75.0  | 30 | 46 | M10x35  | 3/8x1 1/2  | 0.97                            | <b>GFS63/25S</b>                 | 420        |
| 3/4              | 19          | 30S              | 18 | 41.3 | 76.0 | 62.0 | 8.7  | 89.0  | 36 | 50 | M10x35  | 3/8x1 1/2  | 1.15                            | <b>GFS63/30S</b>                 | 420        |
| 3/4              | 19          | 38S              | 18 | 41.3 | 85.0 | 69.0 | 8.7  | 99.5  | 41 | 60 | M10x35  | 3/8x1 1/2  | 1.15                            | <b>GFS63/38S</b>                 | 315        |
| 1                | 25          | 20S              | 16 | 47.6 | 75.0 | 64.5 | 9.5  | 88.0  | 36 | 36 | M12x45  | 7/16x1 3/4 | 0.97                            | <b>GFS64/20S</b>                 | 420        |
| 1                | 25          | 25S              | 20 | 47.6 | 72.0 | 60.0 | 9.5  | 84.0  | 36 | 46 | M12x45  | 7/16x1 3/4 | 1.42                            | <b>GFS64/25S</b>                 | 420        |
| 1                | 25          | 30S              | 24 | 47.6 | 74.0 | 62.0 | 9.5  | 87.0  | 36 | 50 | M12x45  | 7/16x1 3/4 | 1.40                            | <b>GFS64/30S</b>                 | 420        |
| 1                | 25          | 38S              | 24 | 47.6 | 84.5 | 68.0 | 9.5  | 99.0  | 46 | 60 | M12x45  | 7/16x1 3/4 | 1.40                            | <b>GFS64/38S</b>                 | 315        |
| 1 1/4            | 32          | 25S              | 20 | 54.0 | 80.0 | 68.0 | 10.2 | 92.0  | 41 | 46 | M14x50  | 1/2x1 3/4  | 1.85                            | <b>GFS65/25S</b>                 | 420        |
| 1 1/4            | 32          | 30S              | 30 | 54.0 | 79.0 | 65.5 | 10.2 | 92.0  | 41 | 50 | M12x45  |            | 1.95                            | <b>GFS65/30S/12<sup>2)</sup></b> | 420        |
| 1 1/4            | 32          | 38S              | 30 | 54.0 | 83.0 | 67.0 | 10.2 | 97.5  | 46 | 60 | M12x45  |            | 2.16                            | <b>GFS65/38S/12</b>              | 315        |
| 1 1/4            | 32          | 30S              | 30 | 54.0 | 79.0 | 65.5 | 10.2 | 92.0  | 41 | 50 | M14x50  | 1/2x1 3/4  | 1.90                            | <b>GFS65/30S</b>                 | 420        |
| 1 1/4            | 32          | 38S              | 30 | 54.0 | 83.0 | 67.0 | 10.2 | 97.5  | 46 | 60 | M14x50  | 1/2x1 3/4  | 2.10                            | <b>GFS65/38S</b>                 | 315        |
| 1 1/2            | 38          | 30S              | 30 | 63.5 | 90.0 | 74.0 | 12.5 | 103.0 | 46 | 50 | M16x55  | 5/8x2 1/4  | 2.10                            | <b>GFS66/30S</b>                 | 420        |
| 1 1/2            | 38          | 38S              | 30 | 63.5 | 89.0 | 73.0 | 12.5 | 103.5 | 46 | 60 | M16x55  | 5/8x2 1/4  | 3.06                            | <b>GFS66/38S</b>                 | 315        |

<sup>1)</sup>S = heavy series

**Delivery without nut and ring.**

**For nuts and cutting rings see also**

**Industrial Tube Fittings Europe Catalogue 4100.**

<sup>2)</sup>Order code for the flange adapter assembled with FHS35/12CFX and M12X45 bolts.

Please change suffixes according to material/surface required

| Order code suffixes             |                             |                             |  |  |   |
|---------------------------------|-----------------------------|-----------------------------|--|--|---|
| Material                        | Suffix surface and material | Example only flange adapter | Example incl. splitflanges, metr. bolts and O-Ring | Example incl. splitflanges, UNC bolts and O-Ring | Standard sealing material (no additional suffix needed) |
| Steel, zinc plated, Cr(VI)-free | CF                          | GFS62/16SCFX                | GFS62/16SOMDCF                                     | GFS62/16SOMDCFU                                  | NBR   |
| Stainless steel                 | 71                          | GFS62/16S71X                | GFS62/16SOMD71                                     | GFS62/16SOMD71U                                  | VIT   |



**WFS – SAE 90° Elbow flange adapter**

SAE Flange/EO 24° cone end  
(ISO 6162-1)

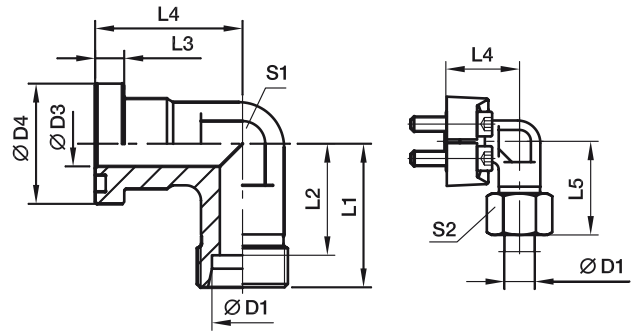

**SAE 3000**

| Nom. flange size |          | D1 <sup>1)</sup> |    |      |    |      |     |    |      |    |    |         | Bolts      |            | Weight (steel)                   | Order code | W.P. |
|------------------|----------|------------------|----|------|----|------|-----|----|------|----|----|---------|------------|------------|----------------------------------|------------|------|
| SAE (in)         | ISO (DN) |                  | D3 | D4   | L1 | L2   | L3  | L4 | L5   | S1 | S2 | (metr.) | (unc.)     | kg/1 piece |                                  |            |      |
| 1/2              | 13       | 12S              | 12 | 30.2 | 50 | 42.5 | 6.7 | 44 | 58.5 | 22 | 24 | M 8x25  | 5/16x1 1/4 | 0.38       | <b>WFS32/12S</b>                 | 210        |      |
| 1/2              | 13       | 15L              | 12 | 30.2 | 36 | 29.0 | 6.7 | 36 | 44   | 24 | 27 | M 8x25  | 5/16x1 1/4 | 0.40       | <b>WFS32/15L</b>                 | 315        |      |
| 1/2              | 13       | 16S              | 12 | 30.2 | 38 | 29.5 | 6.7 | 36 | 48   | 24 | 30 | M 8x25  | 5/16x1 1/4 | 0.43       | <b>WFS32/16S</b>                 | 350        |      |
| 1/2              | 13       | 18L              | 12 | 30.2 | 50 | 42.5 | 6.7 | 44 | 59   | 22 | 32 | M 8x25  | 5/16x1 1/4 | 0.44       | <b>WFS32/18L</b>                 | 315        |      |
| 3/4              | 19       | 16S              | 19 | 38.1 | 64 | 55.5 | 6.7 | 53 | 73.5 | 27 | 30 | M10x30  | 3/8x1 1/4  | 0.60       | <b>WFS33/16S</b>                 | 350        |      |
| 3/4              | 19       | 18L              | 19 | 38.1 | 39 | 31.5 | 6.7 | 42 | 48   | 30 | 32 | M10x30  | 3/8x1 1/4  | 0.66       | <b>WFS33/18L</b>                 | 315        |      |
| 3/4              | 19       | 22L              | 19 | 38.1 | 41 | 33.5 | 6.7 | 42 | 50   | 30 | 36 | M10x30  | 3/8x1 1/4  | 0.66       | <b>WFS33/22L</b>                 | 160        |      |
| 3/4              | 19       | 20S              | 17 | 38.1 | 43 | 32.5 | 6.7 | 42 | 54   | 30 | 36 | M10x30  | 3/8x1 1/4  | 0.76       | <b>WFS33/20S</b>                 | 350        |      |
| 3/4              | 19       | 25S              | 17 | 38.1 | 45 | 33.0 | 6.7 | 42 | 57   | 30 | 46 | M10x30  | 3/8x1 1/4  | 0.89       | <b>WFS33/25S</b>                 | 350        |      |
| 1                | 25       | 20S              | 20 | 44.5 | 65 | 54.5 | 8.0 | 60 | 77   | 34 | 36 | M10x30  | 3/8x1 1/4  | 0.78       | <b>WFS34/20S</b>                 | 350        |      |
| 1                | 25       | 22L              | 18 | 44.5 | 65 | 57.5 | 8.0 | 60 | 74   | 34 | 36 | M10x30  | 3/8x1 1/4  | 0.81       | <b>WFS34/22L</b>                 | 160        |      |
| 1                | 25       | 28L              | 25 | 44.5 | 44 | 36.5 | 8.0 | 45 | 53   | 36 | 41 | M10x30  | 3/8x1 1/4  | 0.85       | <b>WFS34/28L</b>                 | 160        |      |
| 1                | 25       | 25S              | 20 | 44.5 | 48 | 36.5 | 8.0 | 45 | 57   | 36 | 46 | M10x30  | 3/8x1 1/4  | 0.95       | <b>WFS34/25S</b>                 | 350        |      |
| 1                | 25       | 30S              | 24 | 44.5 | 50 | 36.5 | 8.0 | 45 | 63   | 36 | 50 | M10x30  | 3/8x1 1/4  | 1.06       | <b>WFS34/30S</b>                 | 250        |      |
| 1 1/4            | 32       | 35L              | 32 | 50.8 | 57 | 46.5 | 8.0 | 50 | 68   | 41 | 50 | M10x35  | 3/8x1 1/4  | 1.15       | <b>WFS35/35L/10<sup>2)</sup></b> | 160        |      |
| 1 1/4            | 32       | 25S              | 27 | 50.8 | 55 | 43.0 | 8.0 | 60 | 67   | 41 | 46 | M10x35  | 3/8x1 1/4  | 1.35       | <b>WFS35/25S/10</b>              | 200        |      |
| 1 1/4            | 32       | 30S              | 28 | 50.8 | 57 | 43.5 | 8.0 | 50 | 70   | 41 | 50 | M10x35  | 3/8x1 1/4  | 1.40       | <b>WFS35/30S/10</b>              | 200        |      |
| 1 1/4            | 32       | 38S              | 28 | 50.8 | 59 | 43.0 | 8.0 | 50 | 74   | 46 | 60 | M10x35  | 3/8x1 1/4  | 1.53       | <b>WFS35/38S/10</b>              | 200        |      |
| 1 1/4            | 32       | 35L              | 32 | 50.8 | 57 | 46.5 | 8.0 | 50 | 68   | 41 | 50 | M12x40  | 7/16x1 1/2 | 1.15       | <b>WFS35/35L</b>                 | 160        |      |
| 1 1/4            | 32       | 25S              | 27 | 50.8 | 55 | 43.0 | 8.0 | 50 | 67   | 41 | 46 | M12x40  | 7/16x1 1/2 | 1.35       | <b>WFS35/25S</b>                 | 200        |      |
| 1 1/4            | 32       | 30S              | 28 | 50.8 | 57 | 43.5 | 8.0 | 50 | 70   | 41 | 50 | M12x40  | 7/16x1 1/2 | 1.40       | <b>WFS35/30S</b>                 | 200        |      |
| 1 1/4            | 32       | 38S              | 28 | 50.8 | 59 | 43.0 | 8.0 | 50 | 74   | 41 | 60 | M12x40  | 7/16x1 1/2 | 1.53       | <b>WFS35/38S</b>                 | 200        |      |
| 1 1/2            | 38       | 35L              | 30 | 60.3 | 78 | 67.5 | 8.0 | 66 | 83   | 50 | 50 | M12x35  | 1/2x1 1/2  | 1.55       | <b>WFS36/35L</b>                 | 160        |      |
| 1 1/2            | 38       | 42L              | 36 | 60.3 | 58 | 47.0 | 8.0 | 55 | 70   | 50 | 60 | M12x35  | 1/2x1 1/2  | 1.60       | <b>WFS36/42L</b>                 | 160        |      |
| 1 1/2            | 38       | 38S              | 36 | 60.3 | 64 | 48.0 | 8.0 | 55 | 79   | 50 | 60 | M12x35  | 1/2x1 1/2  | 1.95       | <b>WFS36/38S</b>                 | 200        |      |

<sup>1)</sup>L = light series; S = heavy series

**Delivery without nut and ring.**

**For nuts and cutting rings see also**

**Industrial Tube Fittings Europe Catalogue 4100.**

<sup>2)</sup> Order code for the elbow flange adapter assembled with FHS35/10CFX and M10X35 bolts.

Please change suffixes according to material/surface required

| Order code suffixes             |                             |                             |  |  |   |
|---------------------------------|-----------------------------|-----------------------------|--|--|---|
| Material                        | Suffix surface and material | Example only flange adapter | Example incl. splitflanges, metr. bolts and O-Ring | Example incl. splitflanges, UNC bolts and O-Ring | Standard sealing material (no additional suffix needed) |
| Steel, zinc plated, Cr(VI)-free | CF                          | WFS32/16SCFX                | WFS32/16SOMDCF                                     | WFS32/16SOMDCFU                                  | NBR   |
| Stainless steel                 | 71                          | WFS32/16S71X                | WFS32/16SOMD71                                     | WFS32/16SOMD71U                                  | VIT   |

## SAE Flange adapters

### WFS – SAE 90° Elbow flange adapter

SAE Flange/EO 24° cone end  
(ISO 6162-2)

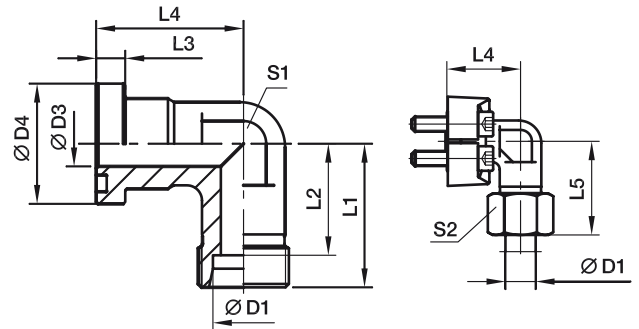

#### SAE 6000

| Nom. flange size |          | D1 <sup>1)</sup> |    |      |    |      |      |    |      |    |    |         | Bolts      |            | Weight (steel)                   | Order code | W.P. |
|------------------|----------|------------------|----|------|----|------|------|----|------|----|----|---------|------------|------------|----------------------------------|------------|------|
| SAE (in)         | ISO (DN) |                  | D3 | D4   | L1 | L2   | L3   | L4 | L5   | S1 | S2 | (metr.) | (unc.)     | kg/1 piece |                                  |            |      |
| 1/2              | 13       | 12S              | 12 | 31.8 | 50 | 43.0 | 7.7  | 44 | 58.5 | 22 | 24 | M 8×30  | 5/16×1 1/4 | 0.37       | <b>WFS62/12S</b>                 | 420        |      |
| 1/2              | 13       | 14S              | 12 | 31.8 | 50 | 43.5 | 7.7  | 44 | 59.5 | 22 | 27 | M 8×30  | 5/16×1 1/4 | 0.39       | <b>WFS62/14S</b>                 | 420        |      |
| 1/2              | 13       | 16S              | 12 | 31.8 | 38 | 29.5 | 7.7  | 39 | 48   | 24 | 30 | M 8×30  | 5/16×1 1/4 | 0.49       | <b>WFS62/16S</b>                 | 420        |      |
| 3/4              | 19       | 16S              | 17 | 41.3 | 45 | 36.5 | 8.7  | 48 | 55   | 32 | 30 | M10×35  | 3/8×1 1/2  | 0.92       | <b>WFS63/16S</b>                 | 420        |      |
| 3/4              | 19       | 20S              | 17 | 41.3 | 46 | 35.5 | 8.7  | 48 | 57   | 32 | 36 | M10×35  | 3/8×1 1/2  | 0.97       | <b>WFS63/20S</b>                 | 420        |      |
| 3/4              | 19       | 25S              | 17 | 41.3 | 48 | 36.0 | 8.7  | 48 | 60   | 32 | 46 | M10×35  | 3/8×1 1/2  | 1.19       | <b>WFS63/25S</b>                 | 420        |      |
| 1                | 25       | 20S              | 16 | 47.6 | 65 | 54.5 | 9.5  | 62 | 75   | 34 | 36 | M12×45  | 7/16×1 3/4 | 1.69       | <b>WFS64/20S</b>                 | 420        |      |
| 1                | 25       | 25S              | 20 | 47.6 | 53 | 44.0 | 9.5  | 60 | 65   | 41 | 46 | M12×45  | 7/16×1 3/4 | 1.67       | <b>WFS64/25S</b>                 | 420        |      |
| 1                | 25       | 30S              | 25 | 47.6 | 55 | 41.5 | 9.5  | 60 | 68   | 41 | 50 | M12×45  | 7/16×1 3/4 | 1.63       | <b>WFS64/30S</b>                 | 420        |      |
| 1 1/4            | 32       | 25S              | 25 | 54.0 | 64 | 52.0 | 10.2 | 55 | 76   | 42 | 46 | M12×45  | 7/16×1 1/2 | 2.23       | <b>WFS65/25S/12<sup>2)</sup></b> | 420        |      |
| 1 1/4            | 32       | 30S              | 30 | 54.0 | 58 | 44.5 | 10.2 | 68 | 71   | 46 | 50 | M12×45  | 7/16×1 1/2 | 2.20       | <b>WFS65/30S/12</b>              | 420        |      |
| 1 1/4            | 32       | 38S              | 30 | 54.0 | 61 | 45.0 | 10.2 | 68 | 76   | 46 | 60 | M12×45  | 7/16×1 1/2 | 2.39       | <b>WFS65/38S/12</b>              | 315        |      |
| 1 1/4            | 32       | 25S              | 25 | 54.0 | 64 | 52.0 | 10.2 | 55 | 76   | 42 | 46 | M14×50  | 1/2×1 3/4  | 2.23       | <b>WFS65/25S</b>                 | 420        |      |
| 1 1/4            | 32       | 30S              | 30 | 54.0 | 58 | 44.5 | 10.2 | 68 | 71   | 46 | 50 | M14×50  | 1/2×1 3/4  | 2.20       | <b>WFS65/30S</b>                 | 420        |      |
| 1 1/4            | 32       | 38S              | 30 | 54.0 | 61 | 45.0 | 10.2 | 68 | 76   | 46 | 60 | M14×50  | 1/2×1 3/4  | 2.39       | <b>WFS65/38S</b>                 | 315        |      |
| 1 1/2            | 38       | 30S              | 25 | 63.5 | 76 | 63.5 | 12.5 | 77 | 90   | 50 | 50 | M16×55  | 5/8×2 1/4  | 2.38       | <b>WFS66/30S</b>                 | 420        |      |
| 1 1/2            | 38       | 38S              | 32 | 63.5 | 72 | 56.0 | 12.5 | 76 | 87   | 50 | 60 | M16×55  | 5/8×2 1/4  | 2.58       | <b>WFS66/38S</b>                 | 315        |      |

<sup>1)</sup>S = heavy series

**Delivery without nut and ring.**

For nuts and cutting rings see also  
**Industrial Tube Fittings Europe Catalogue 4100.**

<sup>2)</sup> Order code for the elbow flange adapter assembled with FHS65/12CFX and M12X45 bolts.

Please change suffixes according to material/surface required

| Order code suffixes             |                             |                             |  |  |   |
|---------------------------------|-----------------------------|-----------------------------|--|--|---|
| Material                        | Suffix surface and material | Example only flange adapter | Example incl. splitflanges, metr. bolts and O-Ring | Example incl. splitflanges, UNC bolts and O-Ring | Standard sealing material (no additional suffix needed) |
| Steel, zinc plated, Cr(VI)-free | CF                          | WFS62/16SCFX                | WFS62/16SOMDCF                                     | WFS62/16SOMDCFU                                  | NBR   |
| Stainless steel                 | 71                          | WFS62/16S71X                | WFS62/16SOMD71                                     | WFS62/16SOMD71U                                  | VIT   |



**L(0)HQ – SAE Straight flange adapter**

SAE Flange/O-Lok® ORFS end  
(ISO 6162-1/-2)

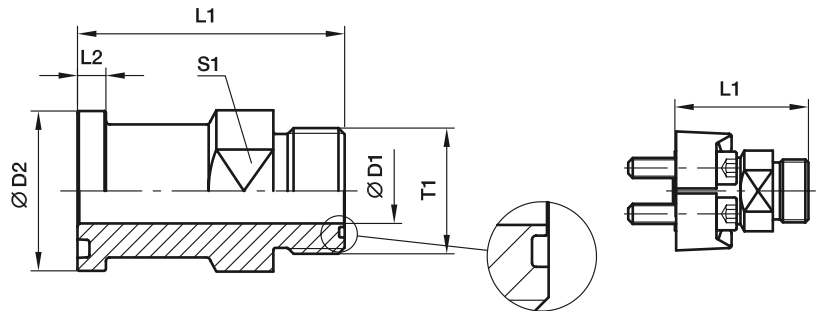

**SAE 3000**

| Nom. flange size |             | Tube       |        | T1                     | D1   | D2   | L1   | L2  | Weight<br>(steel)<br>kg/1 piece | O-Ring face<br>without ORFS | O-Ring face<br>include ORFS | W.P. |
|------------------|-------------|------------|--------|------------------------|------|------|------|-----|---------------------------------|-----------------------------|-----------------------------|------|
| SAE<br>(in)      | ISO<br>(DN) | (metr.)    | (in)   |                        |      |      |      |     |                                 | O-Ring<br>Order code        | O-Ring<br>Order code        |      |
| 3/4              | 19          | 18, 20     | 3/4    | <b>1 3/16-12UN-2A</b>  | 15.5 | 38.1 | 69.6 | 6.7 | 0.21                            | <b>12LHQ1</b>               | <b>12LOHQ1</b>              | 350  |
| 1                | 25          | 22, 25     | 7/8, 1 | <b>1 7/16-12UN-2A</b>  | 20.6 | 44.5 | 71.4 | 8.0 | 0.30                            | <b>16LHQ1</b>               | <b>16LOHQ1</b>              | 350  |
| 1 1/4            | 32          | 28, 30, 32 | 1 1/4  | <b>1 11/16-12UN-2A</b> | 26.0 | 50.8 | 81.5 | 8.0 | 0.31                            | <b>20LHQ1</b>               | <b>20LOHQ1</b>              | 280  |
| 1 1/2            | 38          | 35, 38     | 1 1/2  | <b>2-12UN-2A</b>       | 32.0 | 60.3 | 83.6 | 8.0 | 0.56                            | <b>24LHQ1</b>               | <b>24LOHQ1</b>              | 210  |

**SAE 6000**

|       |    |            |          |                        |      |      |       |      |      |                  |                   |     |
|-------|----|------------|----------|------------------------|------|------|-------|------|------|------------------|-------------------|-----|
| 3/4   | 19 | 18, 20     | 3/4      | <b>1 3/16-12UN-2A</b>  | 15.5 | 41.3 | 76.7  | 8.8  | 0.21 | <b>12LHQ2</b>    | <b>12LOHQ2</b>    | 420 |
| 1     | 25 | 18, 20     | 3/4      | <b>1 3/16-12UN-2A</b>  | 15.5 | 47.6 | 84.8  | 9.5  | 0.26 | <b>12-16LHQ2</b> | <b>12-16LOHQ2</b> | 420 |
| 1     | 25 | 22, 27     | 3/4, 7/8 | <b>1 7/16-12UN-2A</b>  | 20.6 | 47.6 | 85.3  | 9.5  | 0.30 | <b>16LHQ2</b>    | <b>16LOHQ2</b>    | 420 |
| 1 1/4 | 32 | 28, 30, 32 | 1 1/4    | <b>1 11/16-12UN-2A</b> | 26.0 | 54.0 | 88.4  | 10.3 | 0.31 | <b>20LHQ2</b>    | <b>20LOHQ2</b>    | 345 |
| 1 1/2 | 38 | 35, 38     | 1 1/2    | <b>2-12UN-2A</b>       | 32.0 | 63.5 | 105.2 | 12.6 | 0.56 | <b>24LHQ2</b>    | <b>24LOHQ2</b>    | 310 |

Please change suffixes according to material/surface required

| Order code suffixes             |                             |   |   |   |
|---------------------------------|-----------------------------|---|---|---|
| Material                        | Suffix surface and material | Example only flange adapter without ORFS O-Ring | Example only flange adapter incl. ORFS O-Ring | Standard sealing material (no additional suffix needed) |
| Steel, zinc plated, Cr(VI)-free | CF                          | 12LHQ1-CF                                       | 12LOHQ1-CF                                    | NBR   |
| Stainless steel                 | SS                          | 12LHQ1-SS                                       | 12LOHQ1-SS                                    | VIT   |

## SAE Flange adapters

### L(O)EMQ – SAE 90° Elbow flange adapter

SAE Flange/O-Lok® ORFS end  
(ISO 6162-1/-2)

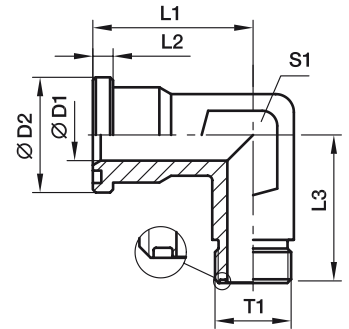

#### SAE 3000

| Nom. flange size |          | Tube       |        | T1                     | D1 | D2   | L1 | L2  | L3 | S1 | Weight (steel)<br>kg/1 piece | O-Ring face without ORFS | O-Ring face include ORFS | W.P. |
|------------------|----------|------------|--------|------------------------|----|------|----|-----|----|----|------------------------------|--------------------------|--------------------------|------|
| SAE (in)         | ISO (DN) | (metr.)    | (in)   |                        |    |      |    |     |    |    |                              | O-Ring Order code        | O-Ring Order code        |      |
| 1/2              | 13       | 8, 10      | 3/8    | <b>11/16-16UN-2A</b>   | 6  | 30.2 | 44 | 6.7 | 50 | 22 | 0.40                         | <b>6-8LEMQ1</b>          | <b>6-8LOEMQ1</b>         | 350  |
| 1/2              | 13       | 12         | 1/2    | <b>13/16-16UN-2A</b>   | 9  | 30.2 | 44 | 6.7 | 50 | 22 | 0.36                         | <b>8LEMQ1</b>            | <b>8LOEMQ1</b>           | 350  |
| 1/2              | 13       | 14, 15, 16 | 5/8    | <b>1-14UN-2A</b>       | 12 | 30.2 | 44 | 6.7 | 50 | 22 | 0.32                         | <b>10-8LEMQ1</b>         | <b>10-8LOEMQ1</b>        | 350  |
| 3/4              | 19       | 14, 15, 16 | 5/8    | <b>1-14UN-2A</b>       | 12 | 38.1 | 53 | 6.7 | 64 | 27 | 0.47                         | <b>10-12LEMQ1</b>        | <b>10-12LOEMQ1</b>       | 350  |
| 3/4              | 19       | 18, 20     | 3/4    | <b>1 3/16-12UN-2A</b>  | 15 | 38.1 | 53 | 6.7 | 64 | 27 | 0.44                         | <b>12LEMQ1</b>           | <b>12LOEMQ1</b>          | 350  |
| 1                | 25       | 18, 20     | 3/4    | <b>1 3/16-12UN-2A</b>  | 15 | 44.4 | 60 | 8.0 | 65 | 34 | 0.52                         | <b>12-16LEMQ1</b>        | <b>12-16LOEMQ1</b>       | 350  |
| 1                | 25       | 22, 25     | 7/8, 1 | <b>1 7/16-12UN-2A</b>  | 20 | 44.4 | 60 | 8.0 | 65 | 34 | 0.50                         | <b>16LEMQ1</b>           | <b>16LOEMQ1</b>          | 350  |
| 1 1/4            | 32       | 22, 25     | 7/8, 1 | <b>1 7/16-12UN-2A</b>  | 20 | 50.8 | 55 | 8.0 | 64 | 42 | 0.48                         | <b>16-20LEMQ1</b>        | <b>16-20LOEMQ1</b>       | 278  |
| 1 1/4            | 32       | 28, 30, 32 | 1 1/4  | <b>1 11/16-12UN-2A</b> | 26 | 50.8 | 55 | 8.0 | 64 | 42 | 0.56                         | <b>20LEMQ1</b>           | <b>20LOEMQ1</b>          | 278  |
| 1 1/2            | 38       | 28, 30, 32 | 1 1/4  | <b>1 11/16-12UN-2A</b> | 26 | 60.3 | 66 | 8.0 | 78 | 50 | 0.73                         | <b>20-24LEMQ1</b>        | <b>20-24LOEMQ1</b>       | 207  |
| 1 1/2            | 38       | 35, 38     | 1 1/2  | <b>2-12UN-2A</b>       | 32 | 60.3 | 66 | 8.0 | 78 | 50 | 0.69                         | <b>24LEMQ1</b>           | <b>24LOEMQ1</b>          | 207  |

#### SAE 6000

|       |    |            |        |                        |    |      |    |      |    |    |      |                   |                    |     |
|-------|----|------------|--------|------------------------|----|------|----|------|----|----|------|-------------------|--------------------|-----|
| 1/2   | 13 | 8, 10      | 3/8    | <b>11/16-16UN-2A</b>   | 6  | 31.8 | 44 | 7.7  | 50 | 22 | 0.40 | <b>6-8LEMQ2</b>   | <b>6-8LOEMQ2</b>   | 420 |
| 1/2   | 13 | 12         | 1/2    | <b>13/16-16UN-2A</b>   | 9  | 31.8 | 44 | 7.7  | 50 | 22 | 0.36 | <b>8LEMQ2</b>     | <b>8LOEMQ2</b>     | 420 |
| 1/2   | 13 | 14, 15, 16 | 5/8    | <b>1-14UN-2A</b>       | 12 | 31.8 | 44 | 7.7  | 50 | 22 | 0.32 | <b>10-8LEMQ2</b>  | <b>10-8LOEMQ2</b>  | 420 |
| 3/4   | 19 | 14, 15, 16 | 5/8    | <b>1-14UN-2A</b>       | 12 | 41.3 | 53 | 8.7  | 64 | 27 | 0.47 | <b>10-12LEMQ2</b> | <b>10-12LOEMQ2</b> | 420 |
| 3/4   | 19 | 18, 20     | 3/4    | <b>1 3/16-12UN-2A</b>  | 15 | 41.3 | 53 | 8.7  | 64 | 27 | 0.44 | <b>12LEMQ2</b>    | <b>12LOEMQ2</b>    | 420 |
| 1     | 25 | 18, 20     | 3/4    | <b>1 3/16-12UN-2A</b>  | 15 | 47.6 | 60 | 9.5  | 62 | 34 | 0.52 | <b>12-16LEMQ2</b> | <b>12-16LOEMQ2</b> | 420 |
| 1     | 25 | 22, 25     | 7/8, 1 | <b>1 7/16-12UN-2A</b>  | 20 | 47.6 | 60 | 9.5  | 62 | 34 | 0.50 | <b>16LEMQ2</b>    | <b>16LOEMQ2</b>    | 420 |
| 1 1/4 | 32 | 22, 25     | 7/8, 1 | <b>1 7/16-12UN-2A</b>  | 20 | 54.0 | 70 | 10.3 | 72 | 42 | 0.48 | <b>16-20LEMQ2</b> | <b>16-20LOEMQ2</b> | 420 |
| 1 1/4 | 32 | 28, 30, 32 | 1 1/4  | <b>1 11/16-12UN-2A</b> | 26 | 54.0 | 70 | 10.3 | 72 | 42 | 0.56 | <b>20LEMQ2</b>    | <b>20LOEMQ2</b>    | 345 |
| 1 1/2 | 38 | 28, 30, 32 | 1 1/4  | <b>1 11/16-12UN-2A</b> | 26 | 63.5 | 80 | 12.5 | 84 | 50 | 0.73 | <b>20-24LEMQ2</b> | <b>20-24LOEMQ2</b> | 345 |
| 1 1/2 | 38 | 35, 38     | 1 1/2  | <b>2-12UN-2A</b>       | 32 | 63.5 | 80 | 12.5 | 84 | 50 | 0.69 | <b>24LEMQ2</b>    | <b>24LOEMQ2</b>    | 310 |

Please change suffixes according to material/surface required

| Order code suffixes             |                             |   |   |   |
|---------------------------------|-----------------------------|---|---|---|
| Material                        | Suffix surface and material | Example only flange adapter without ORFS O-Ring | Example only flange adapter incl. ORFS O-Ring | Standard sealing material (no additional suffix needed) |
| Steel, zinc plated, Cr(VI)-free | CF                          | 12LEMQ1CF                                       | 12LOEMQ1CF                                    | NBR   |
| Stainless steel                 | SS                          | 12LEMQ1SS                                       | 12LOEMQ1SS                                    | VIT   |



**XHQ – SAE Straight flange adapter**

SAE Flange/Triple-Lok® 37° flare end  
(ISO 6162-1/-2)

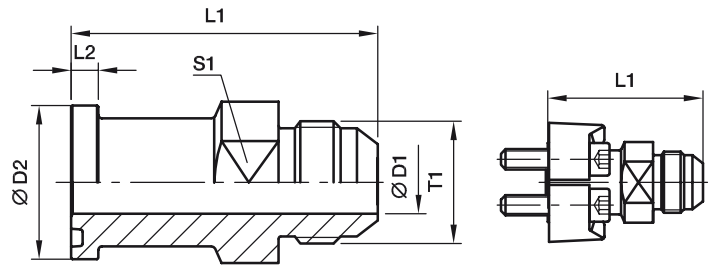

**SAE 3000**

| Nom. flange size |             | <br>Tube |        | T1                    | D1   | D2   | L1    | L2  | Weight<br>(steel)<br>kg/1 piece | Order code    | W.P. |
|------------------|-------------|---|--------|-----------------------|------|------|-------|-----|---------------------------------|---------------|------|
| SAE<br>(in)      | ISO<br>(DN) | (metr.)   | (in)   |                       |      |      |       |     |                                 |               |      |
| 3/4              | 19          | 18, 20  | 3/4    | <b>1 1/16-12UN-2A</b> | 15.5 | 38.1 | 70.4  | 6.7 | 0.21                            | <b>12XHQ1</b> | 350  |
| 1                | 25          | 22, 25  | 7/8, 1 | <b>1 5/16-12UN-2A</b> | 21.5 | 44.5 | 73.9  | 8.0 | 0.30                            | <b>16XHQ1</b> | 350  |
| 1 1/4            | 32          | 28, 30, 32  | 1 1/4  | <b>1 5/8-12UN-2A</b>  | 27.5 | 50.8 | 85.3  | 8.0 | 0.31                            | <b>20XHQ1</b> | 275  |
| 1 1/2            | 38          | 35, 38  | 1 1/2  | <b>1 7/8-12UN-2A</b>  | 33.5 | 60.3 | 90.7  | 8.0 | 0.56                            | <b>24XHQ1</b> | 210  |
| 2                | 51          | 50  | 2      | <b>2 1/2-12UN-2A</b>  | 45.0 | 71.4 | 102.6 | 9.5 | 1.10                            | <b>32XHQ1</b> | 210  |

**SAE 6000**

|       |    |            |        |                       |      |      |       |      |      |               |     |
|-------|----|------------|--------|-----------------------|------|------|-------|------|------|---------------|-----|
| 3/4   | 19 | 18, 20     | 3/4    | <b>1 1/16-12UN-2A</b> | 15.5 | 41.3 | 78.2  | 8.8  | 0.21 | <b>12XHQ2</b> | 350 |
| 1     | 25 | 22, 25     | 7/8, 1 | <b>1 5/16-12UN-2A</b> | 21.5 | 47.6 | 87.1  | 9.5  | 0.30 | <b>16XHQ2</b> | 350 |
| 1 1/4 | 32 | 28, 30, 32 | 1 1/4  | <b>1 5/8-12UN-2A</b>  | 27.5 | 54.0 | 91.4  | 10.3 | 0.31 | <b>20XHQ2</b> | 275 |
| 1 1/2 | 38 | 35, 38     | 1 1/2  | <b>1 7/8-12UN-2A</b>  | 33.5 | 63.5 | 110.2 | 12.6 | 0.56 | <b>24XHQ2</b> | 210 |

Please change suffixes according to material/surface required

| Material                        | Order code suffixes         |                             |   |
|---------------------------------|-----------------------------|-----------------------------|---|
|                                 | Suffix surface and material | Example only flange adapter | Standard sealing material (no additional suffix needed) |
| Steel, zinc plated, Cr(VI)-free | CF                          | 12XHQ1-CF                   | NBR   |
| Stainless steel                 | SS                          | 12XHQ1-SS                   | VIT   |

## SAE Flange adapters

### XEMQ – SAE 90° Elbow flange adapter

SAE Flange/Triple-Lok® 37° flare end  
(ISO 6162-1/-2)

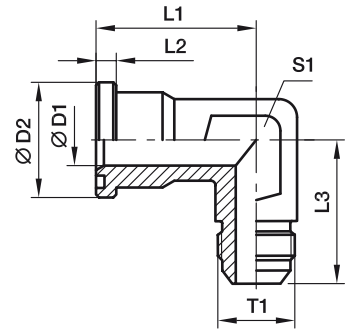

#### SAE 3000

| Nom. flange size |             | Tube       |       | T1                    | D1 | D2   | L1 | L2  | L3 | S1 | Weight<br>(steel)<br>kg/1 piece | Order code        | W.P. |
|------------------|-------------|------------|-------|-----------------------|----|------|----|-----|----|----|---------------------------------|-------------------|------|
| SAE<br>(in)      | ISO<br>(DN) | (metr.)    | (in)  |                       |    |      |    |     |    |    |                                 |                   |      |
| 1/2              | 13          | 12         | 1/2   | <b>3/4-16UNF-2A</b>   | 10 | 30.2 | 44 | 6.7 | 50 | 22 | 0.20                            | <b>8XEMQ1</b>     | 350  |
| 1/2              | 13          | 14, 15, 16 | 5/8   | <b>7/8-14UNF-2A</b>   | 12 | 30.2 | 44 | 6.7 | 50 | 22 | 0.20                            | <b>10-8XEMQ1</b>  | 350  |
| 3/4              | 19          | 14, 15, 16 | 5/8   | <b>7/8-14UNF-2A</b>   | 19 | 38.1 | 53 | 6.7 | 64 | 27 | 0.29                            | <b>10-12XEMQ1</b> | 350  |
| 3/4              | 19          | 18, 20     | 3/4   | <b>1 1/16-12UN-2A</b> | 19 | 38.1 | 53 | 6.7 | 64 | 27 | 0.29                            | <b>12XEMQ1</b>    | 350  |
| 3/4              | 19          | 25         | 1     | <b>1 5/16-12UN-2A</b> | 19 | 38.1 | 53 | 6.7 | 64 | 27 | 0.29                            | <b>16-12XEMQ1</b> | 350  |
| 1                | 25          | 18, 20     | 3/4   | <b>1 1/16-12UN-2A</b> | 22 | 44.4 | 60 | 8.0 | 65 | 34 | 0.39                            | <b>12-16XEMQ1</b> | 350  |
| 1                | 25          | 25         | 1     | <b>1 5/16-12UN-2A</b> | 22 | 44.4 | 60 | 8.0 | 65 | 34 | 0.39                            | <b>16XEMQ1</b>    | 350  |
| 1                | 25          | 30, 32     | 1 1/4 | <b>1 5/8-12UN-2A</b>  | 22 | 44.4 | 60 | 8.0 | 65 | 34 | 0.39                            | <b>20-16XEMQ1</b> | 275  |
| 1 1/4            | 32          | 25         | 1     | <b>1 5/16-12UN-2A</b> | 28 | 50.8 | 55 | 8.0 | 64 | 42 | 0.45                            | <b>16-20XEMQ1</b> | 275  |
| 1 1/4            | 32          | 30, 32     | 1 1/4 | <b>1 5/8-12UN-2A</b>  | 28 | 50.8 | 55 | 8.0 | 64 | 42 | 0.45                            | <b>20XEMQ1</b>    | 275  |
| 1 1/2            | 38          | 30, 32     | 1 1/4 | <b>1 5/8-12UN-2A</b>  | 35 | 60.3 | 66 | 8.0 | 78 | 50 | 0.57                            | <b>20-24XEMQ1</b> | 210  |
| 1 1/2            | 38          | 38         | 1 1/2 | <b>1 7/8-12UN-2A</b>  | 35 | 60.3 | 66 | 8.0 | 78 | 50 | 0.57                            | <b>24XEMQ1</b>    | 210  |

#### SAE 6000

|       |    |            |       |                       |    |      |    |      |    |    |      |                   |     |
|-------|----|------------|-------|-----------------------|----|------|----|------|----|----|------|-------------------|-----|
| 1/2   | 13 | 12         | 1/2   | <b>3/4-16UNF-2A</b>   | 12 | 31.8 | 44 | 7.7  | 50 | 22 | 0.20 | <b>8XEMQ2</b>     | 350 |
| 1/2   | 13 | 14, 15, 16 | 5/8   | <b>7/8-14UNF-2A</b>   | 12 | 31.8 | 44 | 7.7  | 50 | 22 | 0.20 | <b>10-8XEMQ2</b>  | 350 |
| 3/4   | 19 | 14, 15, 16 | 5/8   | <b>7/8-14UNF-2A</b>   | 18 | 41.3 | 53 | 8.7  | 64 | 27 | 0.29 | <b>10-12XEMQ2</b> | 350 |
| 3/4   | 19 | 18, 20     | 3/4   | <b>1 1/16-12UN-2A</b> | 18 | 41.3 | 53 | 8.7  | 64 | 27 | 0.29 | <b>12XEMQ2</b>    | 350 |
| 3/4   | 19 | 25         | 1     | <b>1 5/16-12UN-2A</b> | 18 | 41.3 | 53 | 8.7  | 64 | 27 | 0.29 | <b>16-12XEMQ2</b> | 350 |
| 1     | 25 | 18, 20     | 3/4   | <b>1 1/16-12UN-2A</b> | 22 | 47.6 | 60 | 9.5  | 62 | 34 | 0.39 | <b>12-16XEMQ2</b> | 350 |
| 1     | 25 | 25         | 1     | <b>1 5/16-12UN-2A</b> | 22 | 47.6 | 60 | 9.5  | 62 | 34 | 0.39 | <b>16XEMQ2</b>    | 350 |
| 1     | 25 | 30, 32     | 1 1/4 | <b>1 5/8-12UN-2A</b>  | 22 | 47.6 | 60 | 9.5  | 62 | 34 | 0.39 | <b>20-16XEMQ2</b> | 275 |
| 1 1/4 | 32 | 25         | 1     | <b>1 5/16-12UN-2A</b> | 27 | 54.0 | 70 | 10.3 | 70 | 42 | 0.45 | <b>16-20XEMQ2</b> | 350 |
| 1 1/4 | 32 | 30, 32     | 1 1/4 | <b>1 5/8-12UN-2A</b>  | 27 | 54.0 | 70 | 10.3 | 72 | 42 | 0.45 | <b>20XEMQ2</b>    | 275 |
| 1 1/2 | 38 | 30, 32     | 1 1/4 | <b>1 5/8-12UN-2A</b>  | 32 | 63.5 | 80 | 12.5 | 87 | 50 | 0.57 | <b>20-24XEMQ2</b> | 275 |
| 1 1/2 | 38 | 38         | 1 1/2 | <b>1 7/8-12UN-2A</b>  | 32 | 63.5 | 80 | 12.5 | 87 | 50 | 0.57 | <b>24XEMQ2</b>    | 210 |

Please change suffixes according to material/surface required

| Material                        | Order code suffixes         |                             |   |
|---------------------------------|-----------------------------|-----------------------------|---|
|                                 | Suffix surface and material | Example only flange adapter | Standard sealing material (no additional suffix needed) |
| Steel, zinc plated, Cr(VI)-free | CF                          | 8XEMQ1CF                    | NBR   |
| Stainless steel                 | SS                          | 8XEMQ1SS                    | VIT   |





**PFF-G – SAE Straight 4 bolt flange with BSPP thread**

SAE Flange/Female BSPP thread  
(ISO 6162-1/-2) (ISO 1179-1)

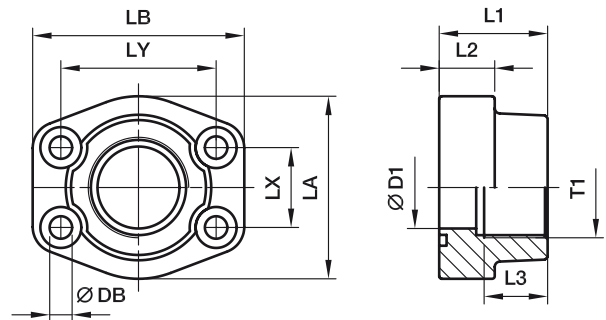

**SAE 3000**

| Nom. flange size |             | T1      | D1  | L1 | L2 | L3 | LA  | LB  | LX   | LY    | DB   | Weight<br>(steel)<br>kg/1 piece | Order code | W.P. |
|------------------|-------------|---------|-----|----|----|----|-----|-----|------|-------|------|---------------------------------|------------|------|
| SAE<br>(in)      | ISO<br>(DN) |         |     |    |    |    |     |     |      |       |      |                                 |            |      |
| 1/2              | 13          | G 3/8   | 13  | 36 | 16 | 19 | 46  | 57  | 17.5 | 38.1  | 9.0  | 0.27                            | PFF32G38   | 345  |
| 1/2              | 13          | G 1/2   | 13  | 36 | 16 | 19 | 46  | 57  | 17.5 | 38.1  | 9.0  | 0.25                            | PFF32G     | 345  |
| 3/4              | 19          | G 3/4   | 19  | 36 | 18 | 19 | 50  | 65  | 22.3 | 47.6  | 11.0 | 0.37                            | PFF33G     | 345  |
| 3/4              | 13          | G 1/2   | 13  | 36 | 18 | 19 | 50  | 65  | 22.3 | 47.6  | 11.0 | 0.40                            | PFF33G12   | 345  |
| 1                | 25          | G 1     | 25  | 38 | 18 | 22 | 55  | 70  | 26.2 | 52.4  | 11.0 | 0.45                            | PFF34G     | 345  |
| 1                | 19          | G 3/4   | 19  | 35 | 21 | 19 | 55  | 70  | 26.2 | 52.4  | 11.0 | 0.45                            | PFF34G34   | 345  |
| 1 1/4            | 32          | G 1 1/4 | 32  | 40 | 21 | 22 | 68  | 79  | 30.2 | 58.7  | 11.5 | 0.66                            | PFF35G     | 276  |
| 1 1/4            | 25          | G 1     | 25  | 42 | 25 | 22 | 65  | 80  | 30.2 | 58.7  | 11.5 | 0.80                            | PFF35G1    | 276  |
| 1 1/2            | 38          | G 1 1/2 | 38  | 45 | 25 | 24 | 78  | 93  | 35.7 | 69.9  | 13.5 | 1.05                            | PFF36G     | 207  |
| 1 1/2            | 32          | G 1 1/4 | 32  | 45 | 27 | 24 | 78  | 95  | 35.7 | 69.9  | 13.5 | 1.17                            | PFF36G114  | 207  |
| 2                | 51          | G 2     | 51  | 45 | 25 | 30 | 89  | 103 | 42.9 | 77.8  | 13.5 | 1.17                            | PFF38G     | 207  |
| 2                | 38          | G 1 1/2 | 38  | 45 | 25 | 26 | 89  | 103 | 42.9 | 77.8  | 13.5 | 1.52                            | PFF38G112  | 207  |
| 2 1/2            | 63          | G 2 1/2 | 63  | 50 | 25 | 30 | 101 | 115 | 50.8 | 88.9  | 13.5 | 1.59                            | PFF310G    | 172  |
| 2 1/2            | 51          | G 2     | 51  | 50 | 25 | 30 | 101 | 115 | 50.8 | 88.9  | 13.5 | 2.13                            | PFF310G2   | 172  |
| 3                | 73          | G 3     | 73  | 50 | 27 | 34 | 124 | 135 | 61.9 | 106.4 | 17.5 | 2.28                            | PFF312G    | 138  |
| 3                | 63          | G 2 1/2 | 63  | 50 | 27 | 30 | 124 | 135 | 61.9 | 106.4 | 17.5 | 2.56                            | PFF312G212 | 138  |
| 3 1/2            | 89          | G 3 1/2 | 89  | 48 | 27 | 34 | 136 | 152 | 69.9 | 120.7 | 17.5 | 2.42                            | PFF314G    | 34   |
| 3 1/2            | 73          | G 3     | 73  | 48 | 27 | 34 | 136 | 152 | 69.9 | 120.7 | 17.5 | 3.28                            | PFF314G3   | 34   |
| 4                | 99          | G 4     | 99  | 48 | 27 | 34 | 146 | 162 | 77.8 | 130.2 | 17.5 | 2.78                            | PFF316G    | 34   |
| 4                | 89          | G 3 1/2 | 89  | 48 | 27 | 34 | 146 | 162 | 77.8 | 130.2 | 17.5 | 3.30                            | PFF316G312 | 34   |
| 5                | 120         | G 5     | 120 | 50 | 28 | 30 | 180 | 184 | 92.1 | 152.4 | 17.5 | 5.80                            | PFF320G    | 34   |

**SAE 6000**

|       |    |         |    |    |    |    |     |     |      |       |       |      |           |     |
|-------|----|---------|----|----|----|----|-----|-----|------|-------|-------|------|-----------|-----|
| 1/2   | 13 | G 3/8   | 13 | 36 | 16 | 19 | 46  | 57  | 18.2 | 40.5  | 9.0   | 0.26 | PFF62G38  | 420 |
| 1/2   | 13 | G 1/2   | 13 | 36 | 16 | 19 | 46  | 57  | 18.2 | 40.5  | 9.0   | 0.29 | PFF62G    | 420 |
| 3/4   | 19 | G 3/4   | 19 | 35 | 21 | 22 | 55  | 71  | 23.8 | 50.8  | 11.0  | 0.50 | PFF63G    | 420 |
| 3/4   | 13 | G 1/2   | 13 | 35 | 21 | 22 | 55  | 71  | 23.8 | 50.8  | 11.0  | 0.50 | PFF63G12  | 420 |
| 1     | 25 | G 1     | 25 | 42 | 25 | 24 | 65  | 81  | 27.8 | 57.2  | 13.0  | 0.76 | PFF64G    | 420 |
| 1     | 19 | G 3/4   | 19 | 42 | 25 | 24 | 65  | 81  | 27.8 | 57.2  | 13.0  | 0.76 | PFF64G34  | 420 |
| 1 1/4 | 32 | G 1 1/4 | 32 | 45 | 27 | 25 | 78  | 95  | 31.8 | 66.6  | 15.0* | 1.20 | PFF65G    | 420 |
| 1 1/4 | 25 | G 1     | 25 | 45 | 27 | 25 | 78  | 95  | 31.8 | 66.6  | 15.0* | 1.20 | PFF65G1   | 420 |
| 1 1/2 | 38 | G 1 1/2 | 38 | 50 | 30 | 28 | 94  | 112 | 36.5 | 79.3  | 17.0  | 1.65 | PFF66G    | 420 |
| 1 1/2 | 32 | G 1 1/4 | 32 | 50 | 30 | 28 | 94  | 112 | 36.5 | 79.3  | 17.0  | 1.65 | PFF66G114 | 420 |
| 2     | 51 | G 2     | 51 | 65 | 37 | 30 | 114 | 134 | 44.5 | 96.8  | 21.0  | 2.45 | PFF68G    | 420 |
| 2     | 38 | G 1 1/2 | 38 | 65 | 37 | 30 | 114 | 134 | 44.5 | 96.8  | 21.0  | 2.45 | PFF68G112 | 420 |
| 2 1/2 | 63 | G 2 1/2 | 63 | 80 | 45 | 32 | 152 | 180 | 58.7 | 123.8 | 25.0  | 3.05 | PFF610G   | 420 |
| 3     | 73 | G 3     | 73 | 90 | 55 | 40 | 178 | 208 | 71.4 | 152.4 | 32.0  | 3.45 | PFF612G   | 420 |

Please change suffixes according to material/surface required

| Order code suffixes |                             |                            |  |  |   |
|---------------------|-----------------------------|----------------------------|--|--|---|
| Material            | Suffix surface and material | Example only 4 bolt flange | Example 4 bolt flange incl. metr. bolts and O-Ring | Example 4 bolt flange incl. UNC bolts and O-Ring | Standard sealing material (no additional suffix needed) |
| Steel, oil dipped   | S                           | PFF32G38S                  | PFF32G38SM   | PFF32G38SU                                       |   |
| Stainless steel     | SS                          | PFF32G38SS                 | PFF32G38SSM  | PFF32G38SSU                                      | VIT   |

## SAE Flange adapters

### PAFSF-G – SAE Straight 4 bolt flange flat with BSPP thread

SAE Flange/Female BSPP thread  
(ISO 6162-1/-2) (ISO 1179-1)

only for low pressure applications

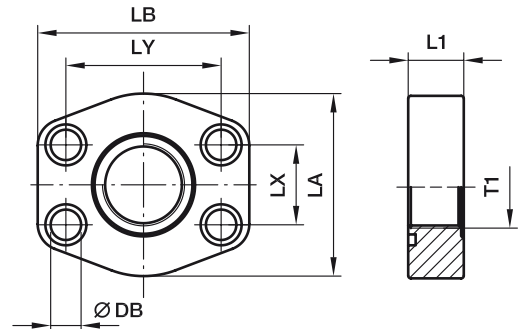

#### SAE 3000

| Nom. flange size |             | T1      | L1 | LA  | LB  | LX   | LY    | DB   | Bolts   |            | O-Ring        | Weight<br>(steel)<br>kg/1 piece | Order code          | W.P. |
|------------------|-------------|---------|----|-----|-----|------|-------|------|---------|------------|---------------|---------------------------------|---------------------|------|
| SAE<br>(in)      | ISO<br>(DN) |         |    |     |     |      |       |      | (metr.) | (unc.)     |               |                                 |                     |      |
| 1/2              | 13          | G 3/8   | 16 | 46  | 58  | 17.5 | 38.1  | 9.0  | M 8×30  | 5/16×1 1/4 | Standard      | 0.20                            | <b>PAFSF080G38</b>  | 40   |
| 1/2              | 13          | G 1/2   | 16 | 46  | 58  | 17.5 | 38.1  | 9.0  | M 8×30  | 5/16×1 1/4 | OR25.07X2.62X | 0.27                            | <b>PAFSF080G</b>    | 40   |
| 3/4              | 19          | G 1/2   | 18 | 49  | 66  | 22.3 | 47.6  | 10.5 | M10×35  | 3/8×1 1/2  | Standard      | 0.29                            | <b>PAFSF100G12</b>  | 40   |
| 3/4              | 19          | G 3/4   | 18 | 49  | 66  | 22.3 | 47.6  | 10.5 | M10×35  | 3/8×1 1/2  | OR31.34X3.53X | 0.27                            | <b>PAFSF100G</b>    | 40   |
| 1                | 25          | G 3/4   | 19 | 53  | 71  | 26.2 | 52.4  | 10.5 | M10×35  | 3/8×1 1/2  | Standard      | 0.32                            | <b>PAFSF102G34</b>  | 40   |
| 1                | 25          | G 1     | 19 | 53  | 71  | 26.2 | 52.4  | 10.5 | M10×35  | 3/8×1 1/2  | OR37.7X3.53X  | 0.31                            | <b>PAFSF102G</b>    | 40   |
| 1 1/4            | 32          | G 1     | 21 | 69  | 80  | 30.2 | 58.7  | 10.5 | M10×35  | 7/16×1 1/2 | Standard      | 0.44                            | <b>PAFSF104G1</b>   | 40   |
| 1 1/4            | 32          | G 1 1/4 | 21 | 69  | 80  | 30.2 | 58.7  | 10.5 | M10×35  | 7/16×1 1/2 | OR44.45X3.53X | 0.56                            | <b>PAFSF104G</b>    | 40   |
| 1 1/2            | 38          | G 1 1/4 | 24 | 77  | 95  | 35.7 | 69.9  | 13.5 | M12×45  | 1/2×1 3/4  | Standard      | 0.83                            | <b>PAFSF106G114</b> | 40   |
| 1 1/2            | 38          | G 1 1/2 | 24 | 77  | 95  | 35.7 | 69.9  | 13.5 | M12×45  | 1/2×1 3/4  | OR52.39X3.53X | 0.76                            | <b>PAFSF106G</b>    | 40   |
| 2                | 51          | G 1 1/2 | 24 | 89  | 103 | 42.9 | 77.8  | 13.5 | M12×45  | 1/2×1 3/4  | Standard      | 1.00                            | <b>PAFSF108G112</b> | 40   |
| 2                | 51          | G 2     | 24 | 89  | 103 | 42.9 | 77.8  | 13.5 | M12×45  | 1/2×1 3/4  | OR65.09X3.53X | 0.90                            | <b>PAFSF108G</b>    | 40   |
| 2 1/2            | 64          | G 2     | 25 | 101 | 116 | 50.8 | 88.9  | 13.5 | M12×45  | 1/2×1 3/4  | Standard      | 1.30                            | <b>PAFSF110G2</b>   | 40   |
| 2 1/2            | 64          | G 2 1/2 | 25 | 101 | 116 | 50.8 | 88.9  | 13.5 | M12×45  | 1/2×1 3/4  | OR78.97X3.53X | 1.25                            | <b>PAFSF110G</b>    | 40   |
| 3                | 76          | G 2 1/2 | 25 | 124 | 136 | 61.9 | 106.4 | 17.0 | M16×55  | 5/8×2 1/4  | Standard      | 1.86                            | <b>PAFSF112G212</b> | 30   |
| 3                | 76          | G 3     | 25 | 124 | 136 | 61.9 | 106.4 | 17.0 | M16×55  | 5/8×2 1/4  | OR94.84X3.53X | 1.49                            | <b>PAFSF112G</b>    | 30   |
| 3 1/2            | 89          | G 3     | 25 | 136 | 152 | 69.9 | 120.7 | 17.0 | M16×55  | 5/8×2 1/4  | Standard      | 1.68                            | <b>PAFSF114G3</b>   | 30   |
| 3 1/2            | 89          | G 3 1/2 | 25 | 136 | 152 | 69.9 | 120.7 | 17.0 | M16×55  | 5/8×2 1/4  | OR107.5X3.53X | 1.59                            | <b>PAFSF114G</b>    | 30   |
| 4                | 102         | G 3 1/2 | 25 | 146 | 162 | 77.8 | 130.2 | 17.0 | M16×55  | 5/8×2 1/4  | Standard      | 2.35                            | <b>PAFSF116G312</b> | 30   |
| 4                | 102         | G 4     | 25 | 146 | 162 | 77.8 | 130.2 | 17.0 | M16×55  | 5/8×2 1/4  | OR117.1X3.53X | 2.25                            | <b>PAFSF116G</b>    | 30   |
| 5                | 127         | G 4     | 25 | 180 | 184 | 92.1 | 152.4 | 17.0 | M16×55  | 5/8×2 1/4  | Standard      | 3.45                            | <b>PAFSF118G4</b>   | 30   |
| 5                | 127         | G 5     | 25 | 180 | 184 | 92.1 | 152.4 | 17.0 | M16×55  | 5/8×2 1/4  | OR145.6X3.53X | 3.15                            | <b>PAFSF118G</b>    | 30   |

#### SAE 6000

|       |    |         |    |     |     |      |      |      |        |            |               |      |                     |    |
|-------|----|---------|----|-----|-----|------|------|------|--------|------------|---------------|------|---------------------|----|
| 1/2   | 13 | G 3/8   | 16 | 46  | 58  | 18.2 | 40.5 | 9.0  | M 8×30 | 5/16×1 1/4 | Standard      | 0.25 | <b>PAFSF401G38</b>  | 40 |
| 1/2   | 13 | G 1/2   | 16 | 46  | 58  | 18.2 | 40.5 | 9.0  | M 8×30 | 5/16×1 1/4 | OR25.07X2.62X | 0.20 | <b>PAFSF401G</b>    | 40 |
| 3/4   | 19 | G 1/2   | 19 | 53  | 71  | 23.8 | 50.8 | 10.5 | M10×35 | 3/8×1 1/2  | Standard      | 0.37 | <b>PAFSF402G12</b>  | 40 |
| 3/4   | 19 | G 3/4   | 19 | 53  | 71  | 23.8 | 50.8 | 10.5 | M10×35 | 3/8×1 1/2  | OR32.92X3.53X | 0.36 | <b>PAFSF402G</b>    | 40 |
| 1     | 25 | G 3/4   | 24 | 66  | 80  | 27.8 | 57.2 | 13.5 | M12×45 | 7/16×1 1/2 | Standard      | 0.64 | <b>PAFSF403G34</b>  | 40 |
| 1     | 25 | G 1     | 24 | 66  | 80  | 27.8 | 57.2 | 13.5 | M12×45 | 7/16×1 1/2 | OR37.7X3.53X  | 0.60 | <b>PAFSF403G</b>    | 40 |
| 1 1/4 | 32 | G 1     | 27 | 77  | 94  | 31.8 | 66.6 | 15.0 | M14×50 | 1/2×1 3/4  | Standard      | 0.88 | <b>PAFSF404G1</b>   | 40 |
| 1 1/4 | 32 | G 1 1/4 | 27 | 77  | 94  | 31.8 | 66.6 | 15.0 | M14×50 | 1/2×1 3/4  | OR44.45X3.53X | 0.87 | <b>PAFSF404G</b>    | 40 |
| 1 1/2 | 38 | G 1 1/4 | 30 | 89  | 103 | 36.5 | 79.3 | 17.0 | M16×55 | 5/8×2 1/4  | Standard      | 1.14 | <b>PAFSF405G114</b> | 40 |
| 1 1/2 | 38 | G 1 1/2 | 30 | 89  | 103 | 36.5 | 79.3 | 17.0 | M16×55 | 5/8×2 1/4  | OR52.39X3.53X | 1.01 | <b>PAFSF405G</b>    | 40 |
| 2     | 51 | G 1 1/2 | 35 | 123 | 135 | 44.5 | 96.8 | 21.0 | M20×70 | 3/4×2 3/4  | Standard      | 2.94 | <b>PAFSF406G112</b> | 40 |
| 2     | 51 | G 2     | 35 | 123 | 135 | 44.5 | 96.8 | 21.0 | M20×70 | 3/4×2 3/4  | OR65.09X3.53X | 2.84 | <b>PAFSF406G</b>    | 40 |

Please change suffixes according to material/surface required

| Order code suffixes |                             |                            |  |  |   |
|---------------------|-----------------------------|----------------------------|--|--|---|
| Material            | Suffix surface and material | Example only 4 bolt flange | Example 4 bolt flange incl. metr. bolts and O-Ring | Example 4 bolt flange incl. UNC bolts and O-Ring | Standard sealing material (no additional suffix needed) |
| Steel, oil dipped   | S                           | PAFSF080GS                 | PAFSF080GSM  | PAFSF080GSU                                      | NBR   |
| Stainless steel     | SS                          | PAFSF080GSS                | PAFSF080GSSM                                       | PAFSF080GSSU                                     | VIT   |



**PEFF-G – SAE 90° 4 bolt flange with BSPP thread**

SAE 90° Flange/Female BSPP thread  
(ISO 6162-1/-2) (ISO 1179-1)

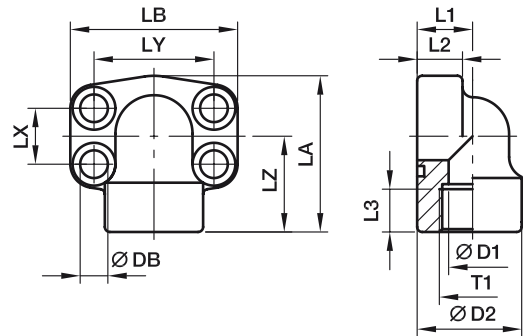

**SAE 3000**

| Nom. flange size |          |         |    |      |    |    |    |     |     |      |      |    |      | Bolts   |            | Weight (steel)<br>kg/1 piece | Order code      | W.P. |
|------------------|----------|---------|----|------|----|----|----|-----|-----|------|------|----|------|---------|------------|------------------------------|-----------------|------|
| SAE (in)         | ISO (DN) | T1      | D1 | D2   | L1 | L2 | L3 | LA  | LB  | LX   | LY   | LZ | DB   | (metr.) | (unc.)     |                              |                 |      |
| 1/2              | 13       | G 1/2   | 13 | 34.0 | 18 | 16 | 16 | 59  | 57  | 17.5 | 38.1 | 36 | 9.0  | M 8x30  | 5/16x1 1/4 | 0.35                         | <b>PEFF32G</b>  | 348  |
| 3/4              | 19       | G 3/4   | 19 | 38.5 | 22 | 18 | 19 | 63  | 68  | 22.3 | 47.6 | 38 | 10.5 | M10x35  | 3/8x1 1/2  | 0.55                         | <b>PEFF33G</b>  | 348  |
| 1                | 25       | G 1     | 25 | 44.5 | 28 | 19 | 19 | 68  | 74  | 26.2 | 52.4 | 41 | 10.5 | M10x35  | 3/8x1 1/2  | 0.80                         | <b>PEFF34G</b>  | 348  |
| 1 1/4            | 32       | G 1 1/4 | 31 | 53.5 | 30 | 22 | 22 | 84  | 81  | 30.2 | 58.7 | 50 | 10.5 | M10x35  | 7/16x1 1/2 | 1.30                         | <b>PEFF35G</b>  | 278  |
| 1 1/2            | 38       | G 1 1/2 | 38 | 62.5 | 36 | 25 | 24 | 97  | 95  | 35.7 | 69.9 | 58 | 13.5 | M12x45  | 1/2x1 3/4  | 1.60                         | <b>PEFF36G</b>  | 210  |
| 2                | 51       | G 2     | 50 | 77.0 | 41 | 25 | 26 | 109 | 105 | 42.9 | 77.8 | 65 | 13.5 | M12x45  | 1/2x1 3/4  | 2.00                         | <b>PEFF38G</b>  | 210  |
| 2 1/2            | 64       | G 2 1/2 | 60 | 89.0 | 50 | 25 | 30 | 127 | 115 | 50.8 | 88.9 | 77 | 13.5 | M12x45  | 1/2x1 3/4  | 2.40                         | <b>PEFF310G</b> | 175  |

**SAE 6000**

|       |    |         |    |      |    |    |    |     |     |      |      |    |        |        |            |      |                |     |
|-------|----|---------|----|------|----|----|----|-----|-----|------|------|----|--------|--------|------------|------|----------------|-----|
| 1/2   | 13 | G 1/2   | 13 | 34.0 | 18 | 16 | 16 | 59  | 57  | 18.2 | 40.5 | 36 | 8.8    | M 8x30 | 5/16x1 1/4 | 0.35 | <b>PEFF62G</b> | 420 |
| 3/4   | 19 | G 3/4   | 19 | 44.5 | 28 | 20 | 22 | 68  | 72  | 23.8 | 50.8 | 41 | 10.5   | M10x35 | 3/8x1 1/2  | 0.80 | <b>PEFF63G</b> | 420 |
| 1     | 25 | G 1     | 25 | 53.5 | 30 | 24 | 24 | 84  | 82  | 27.8 | 57.2 | 50 | 13.5   | M12x45 | 7/16x1 1/2 | 1.30 | <b>PEFF64G</b> | 420 |
| 1 1/4 | 32 | G 1 1/4 | 31 | 62.5 | 36 | 25 | 25 | 97  | 95  | 31.8 | 66.6 | 58 | 15.0** | M14x50 | 1/2x1 3/4  | 1.60 | <b>PEFF65G</b> | 420 |
| 1 1/2 | 38 | G 1 1/2 | 38 | 77.0 | 51 | 26 | 28 | 109 | 110 | 36.5 | 79.3 | 65 | 17.0   | M16x55 | 5/8x2 1/4  | 2.00 | <b>PEFF66G</b> | 420 |
| 2     | 51 | G 2     | 50 | 87.0 | 45 | 35 | 34 | 133 | 134 | 44.5 | 96.8 | 75 | 21.0   | M20x70 | 3/4x2 3/4  | 2.50 | <b>PEFF68G</b> | 420 |

\*\*DB = 13.5 for UNC Bolts

Please change suffixes according to material/surface required

| Order code suffixes |                             |                            |  |  |   |
|---------------------|-----------------------------|----------------------------|--|--|---|
| Material            | Suffix surface and material | Example only 4 bolt flange | Example 4 bolt flange incl. metr. bolts and O-Ring | Example 4 bolt flange incl. UNC bolts and O-Ring | Standard sealing material (no additional suffix needed) |
| Steel, oil dipped   | S                           | PEFF32GS                   | PEFF32GSM  | PEFF32GSU  | NBR   |
| Stainless steel     | SS                          | PEFF32GSS                  | PEFF32GSSM   | PEFF32GSSU                                       | VIT   |

## SAE Flange adapters

### PCFF – SAE Closed flange

SAE Closed flange  
(ISO 6162-1/-2)

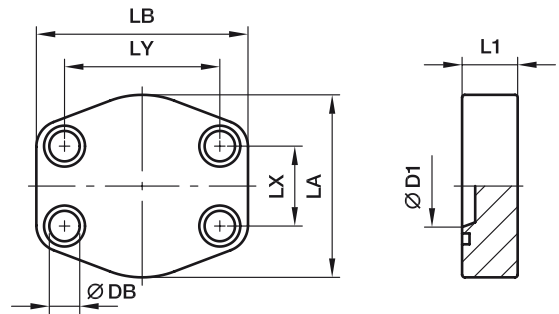

#### SAE 3000

| Nom. flange size |             | D1  | L1 | LA  | LB  | LX   | LY    | DB   | Bolts   |            | Weight<br>(steel)<br>kg/1 piece | Order code     | W.P. |
|------------------|-------------|-----|----|-----|-----|------|-------|------|---------|------------|---------------------------------|----------------|------|
| SAE<br>(in)      | ISO<br>(DN) |     |    |     |     |      |       |      | (metr.) | (unc.)     |                                 |                |      |
| 1/2              | 13          | 13  | 16 | 46  | 58  | 17.5 | 38.1  | 9.0  | M 8×30  | 5/16×1 1/4 | 0.30                            | <b>PCFF32</b>  | 345  |
| 3/4              | 19          | 15  | 18 | 49  | 66  | 22.3 | 47.6  | 10.5 | M10×35  | 3/8×1 1/2  | 0.37                            | <b>PCFF33</b>  | 345  |
| 1                | 25          | 18  | 19 | 53  | 71  | 26.2 | 52.4  | 10.5 | M10×35  | 3/8×1 1/2  | 0.54                            | <b>PCFF34</b>  | 345  |
| 1 1/4            | 32          | 23  | 21 | 69  | 80  | 30.2 | 58.7  | 10.5 | M10×40  | 7/16×1 1/2 | 0.90                            | <b>PCFF35</b>  | 276  |
| 1 1/2            | 38          | 28  | 24 | 77  | 95  | 35.7 | 69.9  | 13.5 | M12×45  | 1/2×1 3/4  | 1.03                            | <b>PCFF36</b>  | 207  |
| 2                | 51          | 45  | 24 | 89  | 103 | 42.9 | 77.8  | 13.5 | M12×45  | 1/2×1 3/4  | 1.30                            | <b>PCFF38</b>  | 207  |
| 2 1/2            | 64          | 58  | 25 | 101 | 116 | 50.8 | 88.9  | 13.5 | M12×45  | 1/2×1 3/4  | 1.45                            | <b>PCFF310</b> | 172  |
| 3                | 76          | 70  | 25 | 124 | 136 | 61.9 | 106.4 | 17.0 | M16×55  | 5/8×2 1/4  | 2.72                            | <b>PCFF312</b> | 138  |
| 3 1/2            | 89          | 85  | 25 | 136 | 152 | 69.9 | 120.7 | 17.0 | M16×55  | 5/8×2 1/4  | 2.90                            | <b>PCFF314</b> | 34   |
| 4                | 102         | 95  | 25 | 146 | 162 | 77.8 | 130.2 | 17.0 | M16×55  | 5/8×2 1/4  | 3.85                            | <b>PCFF316</b> | 34   |
| 5                | 127         | 110 | 25 | 180 | 184 | 92.1 | 152.4 | 17.0 | M16×55  | 5/8×2 1/4  | 4.20                            | <b>PCFF320</b> | 34   |

#### SAE 6000

|       |    |    |    |     |     |      |      |      |        |            |      |               |     |
|-------|----|----|----|-----|-----|------|------|------|--------|------------|------|---------------|-----|
| 1/2   | 13 | 13 | 16 | 46  | 58  | 18.2 | 40.5 | 9.0  | M 8×30 | 5/16×1 1/4 | 0.30 | <b>PCFF62</b> | 420 |
| 3/4   | 19 | 15 | 19 | 53  | 71  | 23.8 | 50.8 | 10.5 | M10×35 | 3/8×1 1/2  | 0.44 | <b>PCFF63</b> | 420 |
| 1     | 25 | 22 | 24 | 66  | 80  | 27.8 | 57.2 | 13.5 | M12×45 | 7/16×1 1/2 | 0.73 | <b>PCFF64</b> | 420 |
| 1 1/4 | 32 | 30 | 27 | 77  | 94  | 31.8 | 66.6 | 15.0 | M14×50 | 1/2×1 3/4  | 0.85 | <b>PCFF65</b> | 420 |
| 1 1/2 | 38 | 35 | 30 | 89  | 103 | 36.5 | 79.3 | 17.0 | M16×55 | 5/8×2 1/4  | 1.61 | <b>PCFF66</b> | 420 |
| 2     | 51 | 48 | 35 | 123 | 135 | 44.5 | 96.8 | 21.0 | M20×70 | 3/4×2 3/4  | 3.31 | <b>PCFF68</b> | 420 |

Please change suffixes according to material/surface required

| Order code suffixes     |                             |                            |  |  |   |
|-------------------------|-----------------------------|----------------------------|--|--|---|
| Material                | Suffix surface and material | Example only closed flange | Example closed flange incl. metr. bolts and O-Ring | Example closed flange incl. UNC bolts and O-Ring | Standard sealing material (no additional suffix needed) |
| Steel, blanc oil dipped | S                           | PCFF32S                    | PCFF32SM   | PCFF32SU   | NBR   |
| Stainless steel         | SS                          | PCFF32SS                   | PCFF32SSM  | PCFF32SSU  | VIT   |



**AP – SAE Flange locking plate**

ISO 6162-1/-2

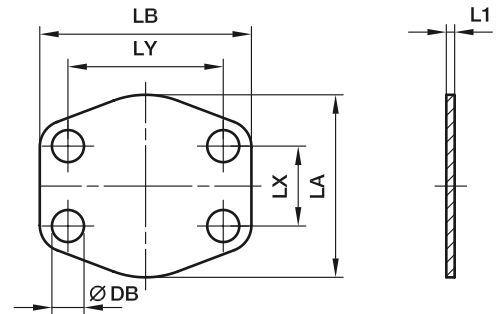

**SAE 3000**

| Nom. flange size |          | L1 | LA  | LB  | LX   | LY    | DB   | Weight (steel) kg/1 piece | Order code   | W.P. |
|------------------|----------|----|-----|-----|------|-------|------|---------------------------|--------------|------|
| SAE (in)         | ISO (DN) |    |     |     |      |       |      |                           |              |      |
| 1/2              | 13       | 3  | 47  | 57  | 17.5 | 38.1  | 9.0  | 0.02                      | <b>8AP1</b>  |      |
| 3/4              | 19       | 3  | 49  | 66  | 22.3 | 47.6  | 11.0 | 0.02                      | <b>12AP1</b> |      |
| 1                | 25       | 3  | 53  | 71  | 26.2 | 52.4  | 11.0 | 0.02                      | <b>16AP1</b> |      |
| 1 1/4            | 32       | 3  | 69  | 80  | 30.2 | 58.7  | 11.5 | 0.03                      | <b>20AP1</b> |      |
| 1 1/2            | 38       | 3  | 77  | 95  | 35.7 | 69.9  | 13.5 | 0.03                      | <b>24AP1</b> |      |
| 2                | 51       | 3  | 89  | 103 | 42.9 | 77.8  | 13.5 | 0.04                      | <b>32AP1</b> |      |
| 2 1/2            | 64       | 3  | 101 | 116 | 50.8 | 89.9  | 13.5 | 0.04                      | <b>40AP1</b> |      |
| 3                | 76       | 4  | 124 | 136 | 61.9 | 106.4 | 17.0 | 0.07                      | <b>48AP1</b> |      |
| 3 1/2            | 89       | 4  | 136 | 152 | 69.9 | 102.7 | 17.0 | 0.07                      | <b>56AP1</b> |      |
| 4                | 102      | 4  | 146 | 162 | 77.8 | 130.2 | 17.0 | 0.09                      | <b>64AP1</b> |      |
| 5                | 127      | 4  | 180 | 184 | 92.1 | 152.4 | 17.0 | 0.10                      | <b>80AP1</b> |      |

**SAE 6000**

|       |    |   |     |     |      |       |      |      |              |  |
|-------|----|---|-----|-----|------|-------|------|------|--------------|--|
| 1/2   | 13 | 4 | 47  | 57  | 18.2 | 40.5  | 9.0  | 0.02 | <b>8AP2</b>  |  |
| 3/4   | 19 | 4 | 53  | 71  | 23.8 | 50.8  | 11.0 | 0.02 | <b>12AP2</b> |  |
| 1     | 25 | 4 | 66  | 80  | 27.8 | 57.1  | 13.0 | 0.03 | <b>16AP2</b> |  |
| 1 1/4 | 32 | 4 | 77  | 94  | 31.8 | 66.7  | 15.0 | 0.04 | <b>20AP2</b> |  |
| 1 1/2 | 38 | 4 | 89  | 103 | 36.5 | 79.4  | 17.0 | 0.05 | <b>24AP2</b> |  |
| 2     | 51 | 4 | 123 | 135 | 44.5 | 96.8  | 21.0 | 0.06 | <b>32AP2</b> |  |
| 2 1/2 | 64 | 4 | 150 | 166 | 58.7 | 123.8 | 25.0 | 0.08 | <b>40AP2</b> |  |
| 3     | 76 | 4 | 178 | 208 | 71.4 | 152.4 | 32.0 | 0.10 | <b>48AP2</b> |  |

This flange locking plate is not used under pressure.

Please change suffixes according to material/surface required

| Order code suffixes             |                             |         |                    |
|---------------------------------|-----------------------------|---------|--------------------|
| Material                        | Suffix surface and material | Example | Description        |
| Steel, zinc plated, Cr(VI)-free | CF                          | 8AP1CF  | only locking plate |
| Stainless steel                 | SS                          | 8AP1SS  | only locking plate |

## SAE Flange adapters

### PRF – SAE Straight reducing flange adapter

SAE 3000  
ISO 6162-1

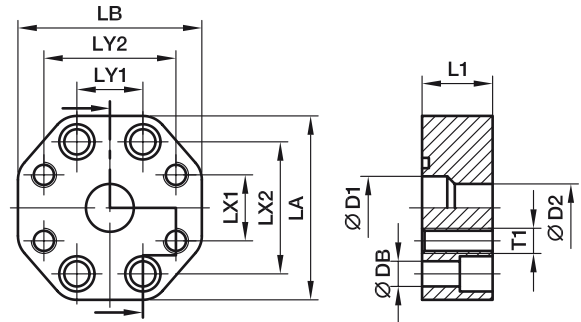

#### SAE 3000

| Nom. flange size |          | D1 | D2 | L1 | LA  | LB  | LX1  | LX2   | LY1  | LY2   | DB | Bolts   |     | Weight (steel)<br>kg/1 piece | Order code        | W.P. |
|------------------|----------|----|----|----|-----|-----|------|-------|------|-------|----|---------|-----|------------------------------|-------------------|------|
| SAE (in)         | ISO (DN) |    |    |    |     |     |      |       |      |       |    | (metr.) | T1  |                              |                   |      |
| 1x1              | 25/25    | 25 | 25 | 28 | 73  | 73  | 26.2 | 52.4  | 26.2 | 52.4  | 11 | M10x35  | M10 | 1.10                         | <b>PRF102/102</b> | 210  |
| 1x3/4            | 25/19    | 25 | 19 | 28 | 73  | 73  | 22.3 | 52.4  | 26.2 | 47.6  | 11 | M10x35  | M10 | 1.15                         | <b>PRF102/100</b> | 210  |
| 1 1/4x1 1/4      | 32/32    | 30 | 30 | 28 | 80  | 80  | 30.2 | 58.7  | 30.2 | 58.7  | 11 | M10x35  | M10 | 1.55                         | <b>PRF104/104</b> | 210  |
| 1 1/4x1          | 32/25    | 30 | 25 | 28 | 80  | 71  | 26.2 | 58.7  | 30.2 | 52.4  | 11 | M10x35  | M10 | 1.55                         | <b>PRF104/102</b> | 210  |
| 1 1/2x1 1/2      | 38/38    | 38 | 38 | 32 | 94  | 94  | 35.7 | 69.9  | 35.7 | 69.9  | 13 | M12x45  | M12 | 2.25                         | <b>PRF106/106</b> | 210  |
| 1 1/2x1 1/4      | 38/32    | 38 | 30 | 32 | 94  | 80  | 30.2 | 69.9  | 35.7 | 58.7  | 13 | M10x35  | M10 | 2.40                         | <b>PRF106/104</b> | 210  |
| 2x2              | 51/51    | 50 | 50 | 33 | 103 | 103 | 42.9 | 77.8  | 42.9 | 77.8  | 13 | M12x45  | M12 | 3.00                         | <b>PRF108/108</b> | 210  |
| 2x1 1/2          | 51/38    | 50 | 38 | 33 | 103 | 94  | 35.7 | 77.8  | 42.9 | 70.0  | 13 | M12x45  | M12 | 3.15                         | <b>PRF108/106</b> | 210  |
| 2 1/2x2 1/2      | 64/64    | 63 | 63 | 33 | 115 | 115 | 50.8 | 88.9  | 50.8 | 88.9  | 13 | M12x45  | M12 | 3.85                         | <b>PRF110/110</b> | 175  |
| 2 1/2x2          | 64/51    | 63 | 50 | 33 | 115 | 103 | 42.9 | 88.9  | 50.8 | 77.8  | 13 | M12x45  | M12 | 3.95                         | <b>PRF110/108</b> | 175  |
| 3x3              | 76/76    | 73 | 73 | 36 | 135 | 135 | 61.9 | 106.4 | 61.9 | 106.4 | 17 | M16x50  | M16 | 4.25                         | <b>PRF112/112</b> | 138  |
| 3x2 1/2          | 76/64    | 73 | 63 | 36 | 135 | 115 | 50.8 | 106.4 | 61.9 | 89.0  | 17 | M12x45  | M12 | 4.45                         | <b>PRF112/110</b> | 138  |

#### 6000 PSI Series

|             |       |    |    |    |     |     |      |       |      |       |    |        |     |      |                   |     |
|-------------|-------|----|----|----|-----|-----|------|-------|------|-------|----|--------|-----|------|-------------------|-----|
| 3/4x3/4     | 19/19 | 19 | 19 | 28 | 71  | 71  | 23.8 | 50.8  | 23.8 | 50.8  | 11 | M10x35 | M10 | 0.80 | <b>PRF402/402</b> | 420 |
| 1x1         | 25/25 | 25 | 25 | 33 | 80  | 80  | 27.8 | 57.2  | 27.8 | 57.2  | 13 | M12x45 | M12 | 1.10 | <b>PRF403/403</b> | 420 |
| 1x3/4       | 25/19 | 25 | 19 | 33 | 80  | 71  | 23.8 | 57.2  | 27.8 | 50.8  | 13 | M10x35 | M10 | 1.10 | <b>PRF403/402</b> | 420 |
| 1 1/4x1 1/4 | 32/32 | 30 | 30 | 33 | 94  | 94  | 31.8 | 66.6  | 31.8 | 66.6  | 15 | M14x45 | M14 | 1.40 | <b>PRF404/404</b> | 420 |
| 1 1/4x1     | 32/25 | 30 | 25 | 33 | 94  | 80  | 27.8 | 66.6  | 31.8 | 57.2  | 15 | M12x45 | M12 | 1.60 | <b>PRF404/403</b> | 420 |
| 1 1/2x1 1/2 | 38/38 | 38 | 38 | 48 | 106 | 106 | 36.5 | 79.3  | 36.5 | 79.3  | 17 | M16x50 | M16 | 3.30 | <b>PRF405/405</b> | 420 |
| 1 1/2x1 1/4 | 38/32 | 38 | 30 | 48 | 106 | 94  | 31.8 | 79.3  | 36.5 | 66.6  | 17 | M14x45 | M14 | 3.60 | <b>PRF405/404</b> | 420 |
| 2x2         | 51/51 | 50 | 50 | 48 | 135 | 135 | 44.5 | 96.8  | 44.5 | 96.8  | 21 | M20x65 | M20 | 5.00 | <b>PRF406/406</b> | 420 |
| 2x1 1/2     | 51/38 | 50 | 38 | 48 | 135 | 106 | 36.5 | 96.8  | 44.5 | 79.3  | 21 | M16x50 | M16 | 5.25 | <b>PRF406/405</b> | 420 |
| 2 1/2x2     | 64/64 | 63 | 63 | 53 | 166 | 166 | 50.8 | 123.8 | 50.8 | 123.8 | 25 | M20x65 | M20 | 6.50 | <b>PRF408/408</b> | 420 |
| 3x2         | 76/51 | 73 | 50 | 58 | 208 | 178 | 44.5 | 152.4 | 71.4 | 96.8  | 31 | M20x65 | M20 | 7.50 | <b>PRF410/406</b> | 420 |

Please change suffixes according to material/surface required

| Order code suffixes             |                             |              |             |
|---------------------------------|-----------------------------|--------------|-------------|
| Material                        | Suffix surface and material | Example      | Description |
| Steel, zinc plated, Cr(VI)-free | S                           | PRF102/102S  | only flange |
| Stainless steel                 | SS                          | PRF102/102SS | only flange |



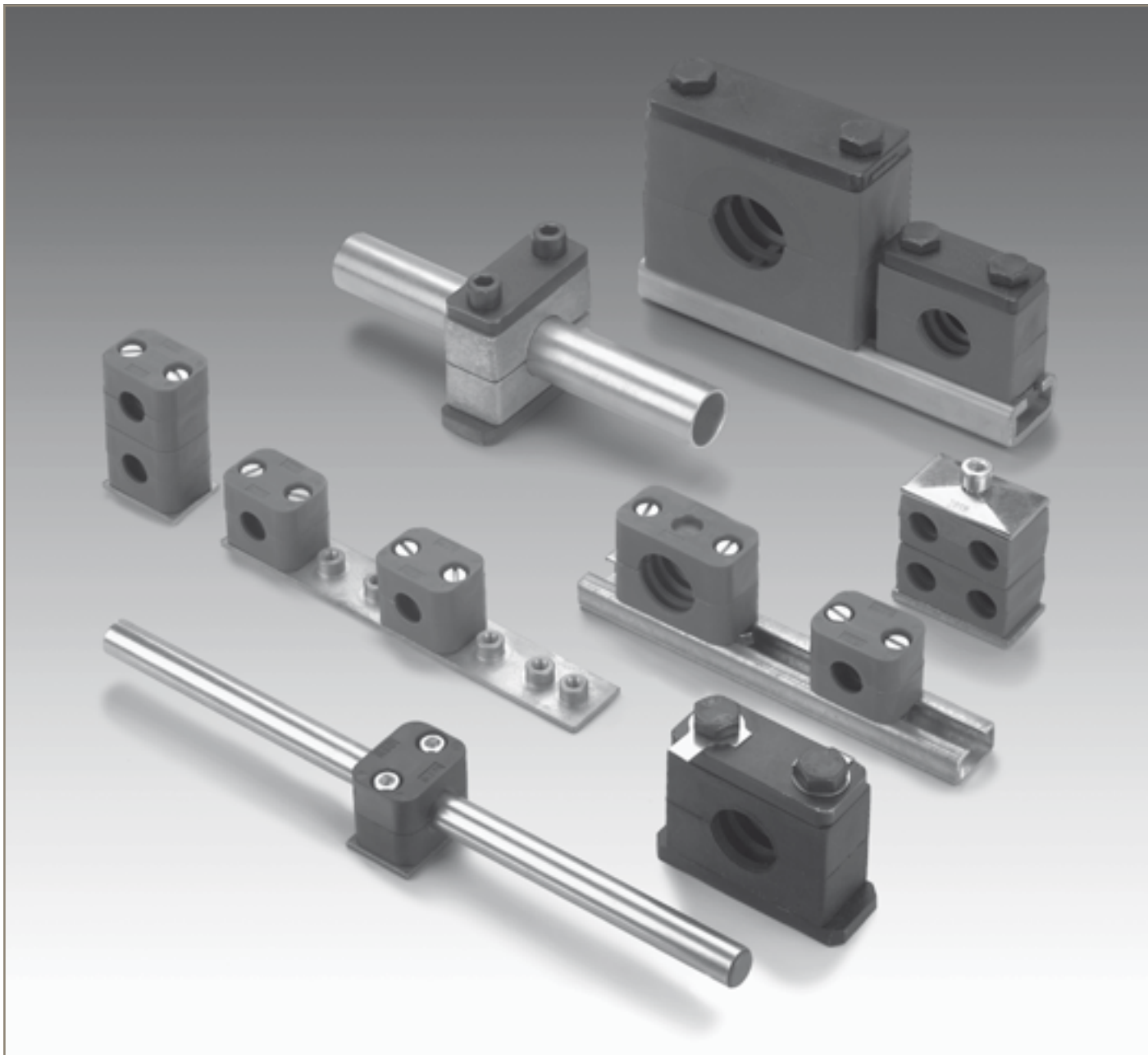

## Tube clamps

ENGINEERING YOUR SUCCESS.

Programme overview

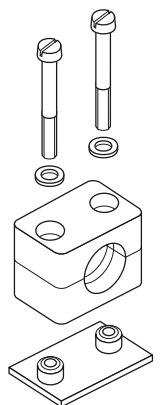
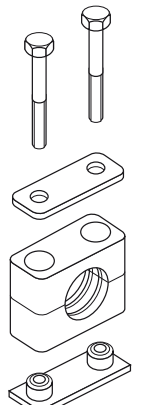
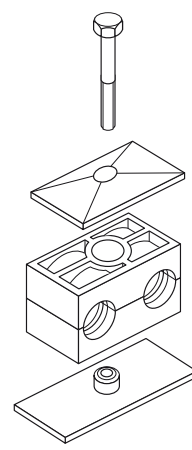
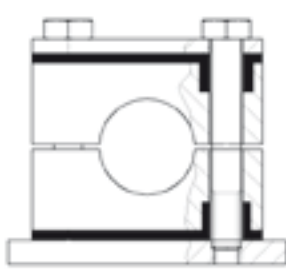
|                                    |   |  |   |
|------------------------------------|---|--|---|
| <p><b>Tube clamps series A</b></p> |  <p>Page 226 - 235</p>   | <p><b>Tube clamps series C</b></p>                             |  <p>Page 241 - 251</p> |
| <p><b>Tube clamps series B</b></p> |  <p>Page 236 - 240</p> | <p><b>Tube clamps series C with absorbing noise insert</b></p> |  <p>Page 252-253</p> |



## Tube clamps

### DIN 3015

**Programme:**

**Tube clamps series A (according to DIN 3015 Part 1)**

Available in seven standard sizes for normal mechanical requirements.

- Outer tube diameter for the metric series 6 to 57 mm
- Outer tube diameter for the inch-size series R 1/8" to R 1 1/2"
- Outer tube diameter for the imperial size series 1/4" to 2 1/2"

The clamp body is available in a round/closed version.

Welding plates, rail-supports, cover plates and construction types.

**Tube clamps series B (according to DIN 3015 Part 3)**

Available as a twin tube clamp in five standard sizes for normal mechanical requirements.

Outer tube diameter 6 to 42 mm.

The clamp body is available in a square/open design.

Welding plates, rail-supports, cover plates and construction types.

Clamp halves with different diameters are only possible when used together.

**Tube clamps series C (according to DIN 3015 Part 2)**

Specially designed for high mechanical requirements, and available in eight standard sizes.

- Outer tube diameter 6 to 220 mm.

The clamp body is available in a square/closed design.

Welding plates, rail-supports, cover plates and construction types.

**Design:**

According to DIN 3015:

Both upper and lower clamp-halves are identical.

Webs inside the bore of the clamps provide an impact and vibration deadening effect, and absorb the forces towards the direction of the tube axis.

When using hoses and cables, we recommend the use of clamp halves with a smooth bore.

**Clamp material:**

|               |             |          |                   |
|---------------|-------------|----------|-------------------|
| Polypropylene | -30°C up to | + 90° C  | colour dark green |
| Polyamide     | -40°C up to | + 120° C | colour black      |
| Rubber        | -50°C up to | + 120° C | colour black      |
| Aluminium     | up to       | + 300° C |                   |

All metal parts available also in stainless steel.

Other materials upon request.

Stainless steel qualities

Stainless steel 1.4401/1.4571 (AISI 316/316 TI), resistant against rust and acid.

**Accessories material:**

Steel. Screws as well as cover plates of series A and B are galvanized.

Rail-supports are also available with zinc plated surface.

**Resistance to stress:**

The remarkable features of Tube Clamps are their considerable re-set capability, high tensile strength, as well as their very high output strength and excellent resistance to cold. The choice of design and clamp material depends on the specific demands of the mechanical and thermal requirements.

**Order code:**

The order code for clamp halves as well as the reference No. for complete tube clamps incorporates the serial indication, material description and interior surface.

**Example of description:**

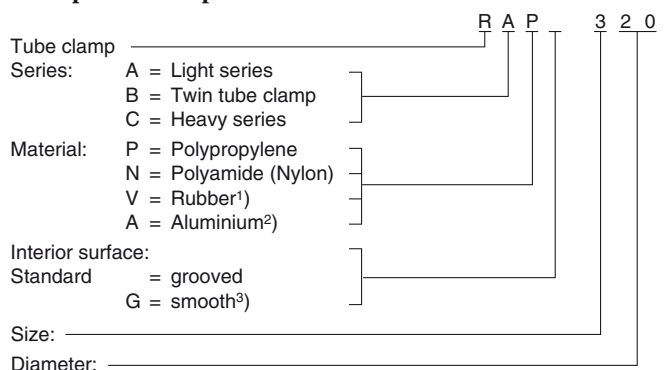

<sup>1)</sup> Rubber only available for series A and B, inside smooth and series C grooved design

<sup>2)</sup> Aluminium only available for series A size 1 to 6 and series C size 1 to 8

<sup>3)</sup> Smooth interior surface in series C only to size 4  
Aluminium clamps only available in a grooved design  
Inside smooth series A only size 1 to 6

**Registration:**

On request

## Tube clamps

### Tube clamps material properties

#### DIN 3015

| Mechanical properties |           | Polypropylene (PP)      | Polyamide 6 (PA 6)          | Aluminium                      | Rubber                             |
|-----------------------|-----------|-------------------------|-----------------------------|--------------------------------|------------------------------------|
| Density               |           | 0.906 g/cm <sup>3</sup> | 1.12–1.15g/cm <sup>3</sup>  | 2.65 g/cm <sup>3</sup>         | 0.98 g/cm <sup>3</sup>             |
| Flexural deflection   | DIN 53452 | 36 N/mm <sup>2</sup>    | 130...200 N/mm <sup>2</sup> | 70 N/mm <sup>2</sup>           | –                                  |
| Impact resistance     | DIN 53453 | no break                | no break                    | –                              |                                    |
| Compressive strength  | DIN 53454 | 90 N/mm <sup>2</sup>    | 120 N/mm <sup>2</sup>       | HB 500...600 N/mm <sup>2</sup> | A and B: 64° shore<br>C: 73° shore |
| Modulus of elasticity | DIN 53452 | 1500 N/mm <sup>2</sup>  | 3000 N/mm <sup>2</sup>      | 70.000 N/mm <sup>2</sup>       |                                    |
| Tensile strength      |           |                         |                             |                                | A and B: 6.1 N/mm <sup>2</sup>     |
| without breakage      | DIN 53454 | 25–35 N/mm <sup>2</sup> | 80–90 N/mm <sup>2</sup>     | 180 N/mm <sup>2</sup>          | C: 8.5 N/mm <sup>2</sup>           |

| Thermal properties |  |                |                 |       |                |
|--------------------|--|----------------|-----------------|-------|----------------|
| Temp. resistance   |  | –30 ... + 90°C | –40 ... + 120°C | 300°C | –50 ... +120°C |

| Chemical properties |  |                   |                   |  |                   |
|---------------------|--|-------------------|-------------------|--|-------------------|
| Weak acids          |  | limited resistant | limited resistant |  | resistant         |
| Weak alkalis        |  | limited resistant | limited resistant |  | resistant         |
| Alcohol             |  | resistant         | resistant         |  | resistant         |
| Petrol              |  | limited resistant | resistant         |  | limited resistant |
| Mineral oils        |  | resistant         | resistant         |  | resistant         |
| Other oils          |  | resistant         | resistant         |  | resistant         |

The outlined particulars are approximate values and are only shown for reference, which are not binding, and with regard to possible protection of third parties. They do not exempt you from your own examination of suitability of the products delivered by us. Therefore, these values can only be used in a limited way for guidance only.

The application of the products is carried out outside of our control and, therefore, is exclusively subject to your own area of responsibility. Any claim however would be limited for all damages to the value of the goods supplied by us and in use by you.

It goes without saying, that we guarantee the perfect quality of our products according to our general sales and delivery conditions.

## Tube clamps assembly instruction

DIN 3015

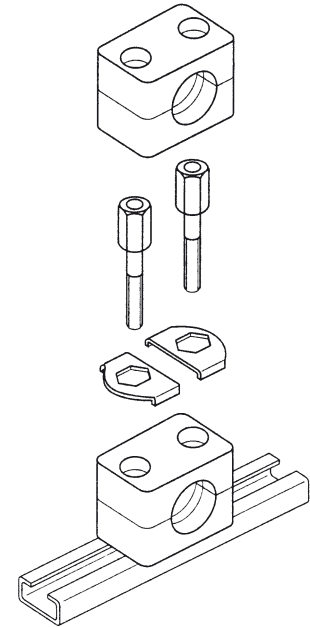
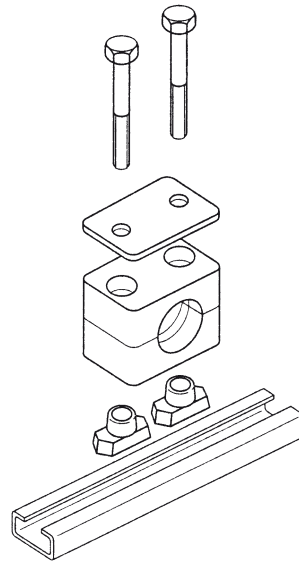
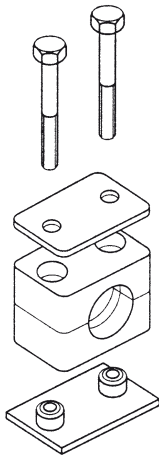

### Assembly:

#### Assembly on to metal welding plates

Place welding plates on a base appropriate for the load. Make sure that the clamps are properly aligned. Clamp lower clamp half onto welding plate, insert tube, place upper clamp half onto lower half and fasten with the screws. Attention must be paid to the bias (after completed assembly, clamp halves may not be in contact)! Do not weld with fitted plastic clamp!  
Extended welding plates may be screw-fastened to the base.

#### Assembly on support rails

Support rails are available in four different heights and come in pieces of 1 m or 2 m length, as required. Weld on support rail or screw-fasten with fastening angle bracket. Insert support rail nuts in rail and turn until stoppage. For heavy duty construction series, nuts are simply pushed in. Clamp lower clamp half on support rail nuts, insert tube, place upper clamp half onto lower half and fasten with the screws. Before fastening the screws the clamp may still be positioned. Attention must be paid to the bias (after completed assembly, the clamp halves may not be in contact)!

#### Construction assembly

Clamps allow the assembly of multiple clamps of the same construction size and of different tube diameters one above the other. The construction assembly is carried out with special fixing screws that are secured against twisting by applying a locking plate. Clamp lower clamp half on welding plate or support rail respectively, insert tube, place upper clamp half on lower half and fasten with fixing screws. The fixing screw juts out from the upper clamp half. The application of a locking plate securely fastens the fixing screw and prevents twisting. Clamp on second clamp half on to the fixing screws etc.

## Tube clamps

### Tube clamps series A (Light construction series) – Components

DIN 3015, part 1

**Order code for clamp halves:**

Polypropylene – **RAP**  
 Inside smooth – **RAPG**  
 Polyamide 6 – **RAN**  
 Inside smooth – **RANG**  
 Rubber – **RAVG**  
 Aluminium – **RAA<sup>1)</sup>**

(Please exchange as required standard abbreviation  
 RAP in column for “clamp halves”)

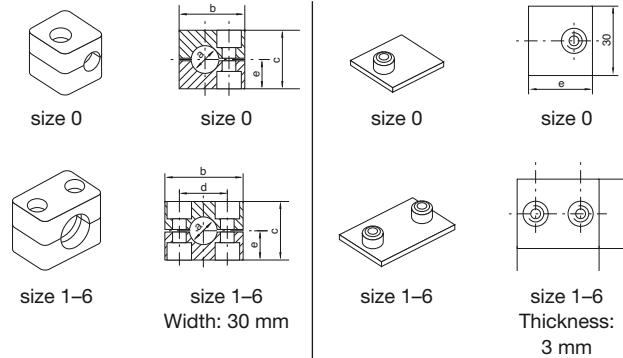

| clamp size | Tube O.D. mm<br>a | Tube NB | Tube O.D. | 1 part<br>2 clamp halves   |                        |    |    | welding plate, short |                        |                    |    |
|------------|-------------------|---------|-----------|--|------------------------|----|----|----------------------|------------------------|--------------------|----|
|            |                   |         |           | RAP...<br>Order code   | dimensions:<br>b c d e |    |    |                      | APK A...<br>Order code | dimensions:<br>d e |    |
| 0          | 6.0               | G 1/8   | 1/4       | RAP006X<br>RAP006.4X<br>RAP008X<br>RAP009.5X<br>RAP010X<br>RAP012X                       | 28                     | 27 | -  | 13.5                 | APKA0X                 | 30                 |    |
|            | 6.4               |         |           |  |                        |    |    |                      |                        |                    |    |
|            | 8.0               |         |           |  |                        |    |    |                      |                        |                    |    |
|            | 9.5               |         |           |  |                        |    |    |                      |                        |                    |    |
|            | 10.0              |         |           |  |                        |    |    |                      |                        |                    |    |
|            | 12.0              |         |           |  |                        |    |    |                      |                        |                    |    |
| 1          | 6.0               | G 1/8   | 1/4       | RAP106X<br>RAP106.4X<br>RAP108X<br>RAP109.5X<br>RAP110X<br>RAP112X                       | 34                     | 27 | 20 | 13.5                 | APKA1X                 | 20                 | 36 |
|            | 6.4               |         |           |  |                        |    |    |                      |                        |                    |    |
|            | 8.0               |         |           |  |                        |    |    |                      |                        |                    |    |
|            | 9.5               |         |           |  |                        |    |    |                      |                        |                    |    |
|            | 10.0              |         |           |  |                        |    |    |                      |                        |                    |    |
|            | 12.0              |         |           |  |                        |    |    |                      |                        |                    |    |
| 2          | 12.7              | G 1/4   | 1/2       | RAP212.7X<br>RAP213.5X<br>RAP214X<br>RAP215X<br>RAP216X<br>RAP217.2X<br>RAP218X          | 40                     | 33 | 26 | 16.5                 | APKA2X                 | 26                 | 42 |
|            | 13.5              |         |           |  |                        |    |    |                      |                        |                    |    |
|            | 14.0              |         |           |  |                        |    |    |                      |                        |                    |    |
|            | 15.0              | G 3/8   | 5/8       |  |                        |    |    |                      |                        |                    |    |
|            | 16.0              |         |           |  |                        |    |    |                      |                        |                    |    |
|            | 17.2              |         |           |  |                        |    |    |                      |                        |                    |    |
| 18.0       |                   |         |           |  |                        |    |    |                      |                        |                    |    |
| 3          | 19.0              | G 1/2   | 3/4       | RAP319X<br>RAP320X<br>RAP321.3X<br>RAP322X<br>RAP323X<br>RAP325X                         | 48                     | 35 | 33 | 17.5                 | APKA3X                 | 33                 | 50 |
|            | 20.0              |         |           |  |                        |    |    |                      |                        |                    |    |
|            | 21.3              |         |           |  |                        |    |    |                      |                        |                    |    |
|            | 22.0              |         |           |  |                        |    |    |                      |                        |                    |    |
|            | 23.0              |         |           |  |                        |    |    |                      |                        |                    |    |
|            | 25.0              |         |           |  |                        |    |    |                      |                        |                    |    |
| 4          | 26.9              | G 3/4   | 1         | RAP426.9X<br>RAP428X<br>RAP430X  | 57                     | 42 | 40 | 21                   | APKA4X                 | 40                 | 59 |
|            | 28.0              |         |           |  |                        |    |    |                      |                        |                    |    |
|            | 30.0              |         |           |  |                        |    |    |                      |                        |                    |    |
| 5          | 32.0              | G 1     | 1 1/4     | RAP532X<br>RAP533.7X<br>RAP535X<br>RAP538X<br>RAP540X<br>RAP542X                         | 70                     | 58 | 52 | 29                   | APKA5X                 | 52                 | 72 |
|            | 33.7              |         |           |  |                        |    |    |                      |                        |                    |    |
|            | 35.0              |         |           |  |                        |    |    |                      |                        |                    |    |
|            | 38.0              | G 1 1/4 | 1 1/2     |  |                        |    |    |                      |                        |                    |    |
|            | 40.0              |         |           |  |                        |    |    |                      |                        |                    |    |
|            | 42.0              |         |           |  |                        |    |    |                      |                        |                    |    |
| 6          | 44.5              | G 1 1/2 | 1 3/4     | RAP644.5X<br>RAP645X<br>RAP648X<br>RAP650X<br>RAP650.8X<br>RAP652X<br>RAP655X<br>RAP657X | 86                     | 66 | 66 | 33                   | APKA6X                 | 66                 | 88 |
|            | 45.0              |         |           |  |                        |    |    |                      |                        |                    |    |
|            | 48.0              |         |           |  |                        |    |    |                      |                        |                    |    |
|            | 50.0              |         |           |  |                        |    |    |                      |                        |                    |    |
|            | 50.8              |         |           |  |                        |    |    |                      |                        |                    |    |
|            | 52.0              |         |           |  |                        |    |    |                      |                        |                    |    |
|            | 55.0              |         |           |  |                        |    |    |                      |                        |                    |    |
|            | 57.0              | 2       |           |  |                        |    |    |                      |                        |                    |    |
|            | 2 1/4             |         |           |  |                        |    |    |                      |                        |                    |    |

When assembling solid rubber clamps, covering plates, hexagon screws and locking washers must be used. All metal parts available in stainless steel.

<sup>1)</sup> Aluminium only sizes 1 to 6.



**Tube clamps series A (Light construction series) – Components**

DIN 3015, part 1

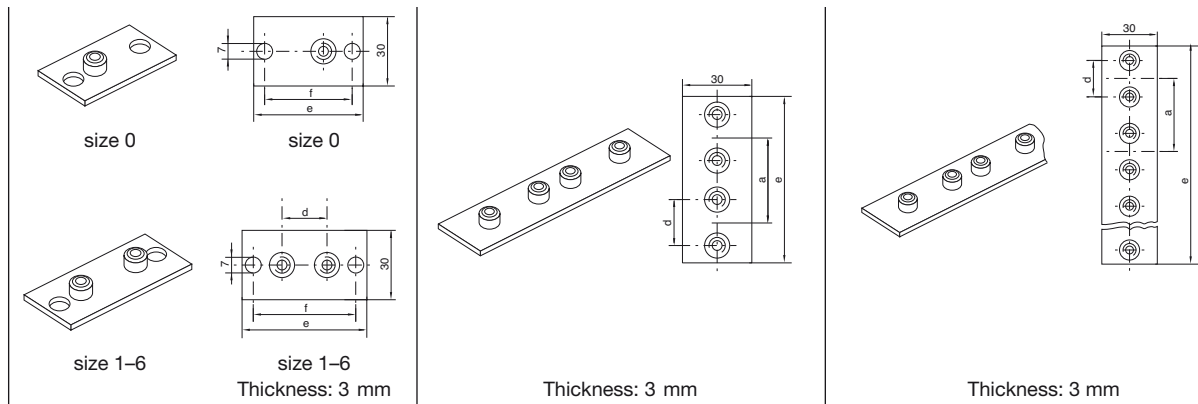

| clamp size | weld/screw plate, long |                      |     | twin welding plate |                        |                      | multiple weld plate |     |                              |                      |     |     |
|------------|------------------------|----------------------|-----|--------------------|------------------------|----------------------|---------------------|-----|------------------------------|----------------------|-----|-----|
|            | APL A...<br>Order code | dimensions:<br>d e f |     |                    | APD A...<br>Order code | dimensions:<br>d a e |                     |     | APR A...<br>Order code       | dimensions:<br>d a e |     |     |
| 0          | <b>APLA0X</b>          | 58                   | 44  |                    | <b>APDA0X</b>          | 30                   | 61                  |     | <b>APRA0X</b><br>(10 clamps) | 30                   | 298 |     |
| 1          | <b>APLA1X</b>          | 20                   | 64  | 50                 | <b>APDA1X</b>          | 20                   | 35                  | 69  | <b>APRA1X</b><br>(10 clamps) | 20                   | 35  | 349 |
| 2          | <b>APLA2X</b>          | 26                   | 70  | 56                 | <b>APDA2X</b>          | 26                   | 43                  | 86  | <b>APRA2X</b><br>(10 clamps) | 26                   | 43  | 427 |
| 3          | <b>APLA3X</b>          | 33                   | 78  | 64                 | <b>APDA3X</b>          | 33                   | 52                  | 104 | <b>APRA3X</b><br>(10 clamps) | 33                   | 52  | 516 |
| 4          | <b>APLA4X</b>          | 40                   | 87  | 73                 | <b>APDA4X</b>          | 40                   | 60                  | 117 | <b>APRA4X</b><br>(5 clamps)  | 40                   | 60  | 297 |
| 5          | <b>APLA5X</b>          | 52                   | 100 | 86                 | <b>APDA5X</b>          | 52                   | 75                  | 145 | <b>APRA5X</b><br>(5 clamps)  | 52                   | 75  | 370 |
| 6          | <b>APLA6X</b>          | 66                   | 116 | 100                | <b>APDA6X</b>          | 66                   | 90                  | 176 | <b>APRA6X</b><br>(5 clamps)  | 66                   | 90  | 446 |

Metal parts also available in stainless steel.

## Tube clamps

### Tube clamps series A (Light construction series) – Components

DIN 3015, part 1

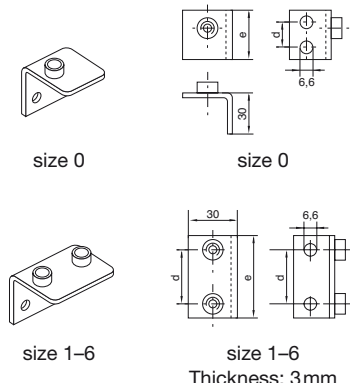
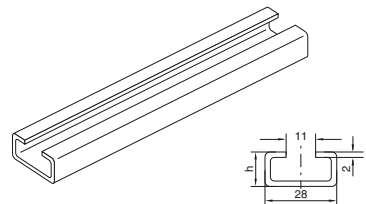
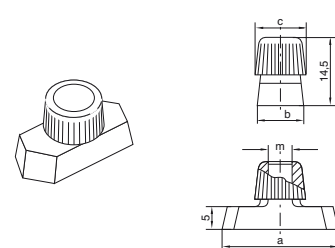
|            |  <p>size 0</p> <p>size 0</p> <p>size 1-6</p> <p>size 1-6<br/>Thickness: 3mm</p> |                    |  <p>1 or 2 mtr</p> |                                  |  |                        |  |  |  |
|------------|--|--------------------|--|----------------------------------|---|------------------------|--|--|--|
| clamp size | weld plate, angled   |                    | mounting rail  |                                  | rail nut  |                        |  |  |  |
|            | APW A...<br>Order code   | dimensions:<br>d e | TS...A/B<br>Order code   | dimensions:<br>h                 | TM...A/B1<br>Order code   | dimensions:<br>a b c m |  |  |  |
| 0          | APWA0X   | 14 30              | TS11A/B1X<br>TS11A/B2X<br>TS14A/B1X<br>TS14A/B2X<br>TS30A/B1X<br>TS30A/B2X                           | TS11: 11<br>TS14: 14<br>TS30: 30 | TMA/TMB1VERZX   | 25.4 10.4 12 M6        |  |  |  |
| 1          | APWA1X   | 20 36              |  |                                  |   |                        |  |  |  |
| 2          | APWA2X   | 26 42              |  |                                  |   |                        |  |  |  |
| 3          | APWA3X   | 33 50              |  |                                  |   |                        |  |  |  |
| 4          | APWA4X   | 40 59              |  |                                  |   |                        |  |  |  |
| 5          | APWA5X   | 52 72              |  |                                  |   |                        |  |  |  |
| 6          | APWA6X   | 66 88              |  |                                  |   |                        |  |  |  |

Metal parts also available in stainless steel.

**Tube clamps series A (Light construction series) – Components**

DIN 3015, part 1

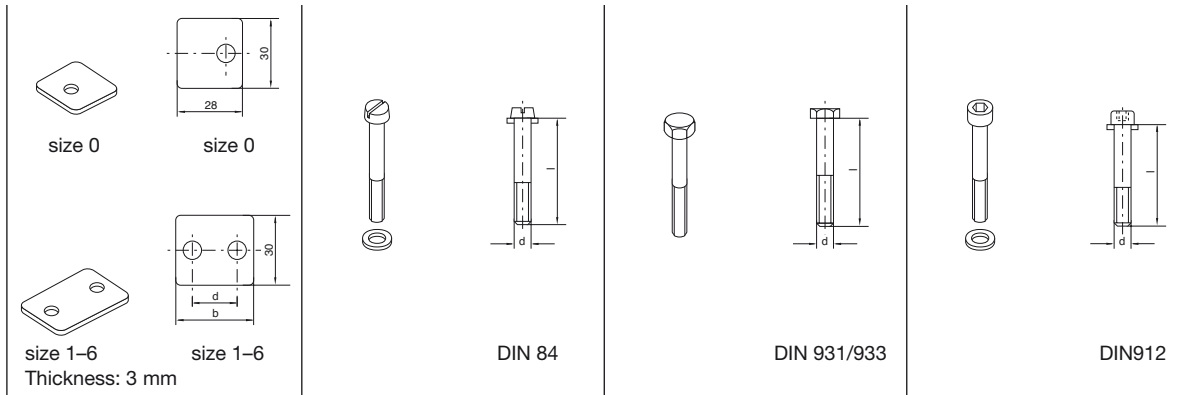

| clamp size | cover plate           |                    | slot head             |                      | hexagon head           |                      | socket head           |                      |
|------------|-----------------------|--------------------|-----------------------|----------------------|------------------------|----------------------|-----------------------|----------------------|
|            | DP A...<br>Order code | dimensions:<br>b d | SL A...<br>Order code | dimensions:<br>d x L | SSL A...<br>Order code | dimensions:<br>d x L | IS A...<br>Order code | dimensions:<br>d x L |
| 0          | <b>DPA0X</b>          | – –                | <b>SLA0X</b>          | M 6 x 20             | <b>SSL10X</b>          | M 6 x 30             | <b>ISA0X</b>          | M 6 x 20             |
| 1          | <b>DPA1X</b>          | 34 20              | <b>SLA1X</b>          | M 6 x 20             | <b>SSLA0X</b>          | M 6 x 30             | <b>ISA1X</b>          | M 6 x 20             |
| 2          | <b>DPA2X</b>          | 40 26              | <b>SLA2X</b>          | M 6 x 25             | <b>SSLA2/SSB1X</b>     | M 6 x 35             | <b>ISA2X</b>          | M 6 x 25             |
| 3          | <b>DPA3X</b>          | 48 33              | <b>SLA3X</b>          | M 6 x 30             | <b>SSLA3X</b>          | M 6 x 40             | <b>ISA3X</b>          | M 6 x 30             |
| 4          | <b>DPA4X</b>          | 57 40              | <b>SLA4X</b>          | M 6 x 35             | <b>SSLA4X</b>          | M 6 x 45             | <b>ISA4X</b>          | M 6 x 35             |
| 5          | <b>DPA5X</b>          | 70 52              | <b>SLA5X</b>          | M 6 x 50             | <b>SSLA5X</b>          | M 6 x 60             | <b>ISA5X</b>          | M 6 x 50             |
| 6          | <b>DPA6X</b>          | 86 66              | <b>SLA6X</b>          | M 6 x 60             | <b>SSLA6X</b>          | M 6 x 70             | <b>ISA6X</b>          | M 6 x 60             |

All metal parts available in stainless steel.

## Tube clamps

### Tube clamps series A (Light construction series) – Components

DIN 3015, part 1

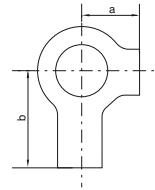
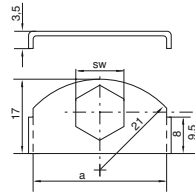
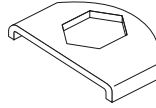
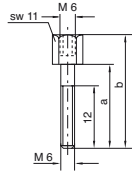
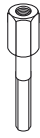

| clamp size | stacking <sup>1)</sup>    |                       | locking plate <sup>1)</sup> |                        | locking washer <sup>2)</sup> |                       |
|------------|---------------------------|-----------------------|-----------------------------|------------------------|------------------------------|-----------------------|
|            | AS A...<br>Order code     | dimensions:<br>a    b | SB A<br>Order code          | dimensions:<br>a    SW | US A<br>Order code           | dimensions:<br>a    b |
| 0          | <b>ASA0X<br/>(AS B1X)</b> | 20    34              | <b>SBAX</b>                 | 30    11               | <b>USA/USB1X</b>             | 9    18               |
| 1          | <b>ASA0X<br/>(ASB1X)</b>  | 20    34              |                             |                        |                              |                       |
| 2          | <b>ASA2X</b>              | 25    39              |                             |                        |                              |                       |
| 3          | <b>ASA3X</b>              | 30    44              |                             |                        |                              |                       |
| 4          | <b>ASA4X</b>              | 35    49              |                             |                        |                              |                       |
| 5          | <b>ASA5X</b>              | 50    64              |                             |                        |                              |                       |
| 6          | <b>ASA6X</b>              | 60    74              |                             |                        |                              |                       |

<sup>1)</sup> The use of stacking bolts necessitates the use of locking plates in the construction assembly.

<sup>2)</sup> When assembling solid rubber clamps, cover plates, hexagon screws and locking washers must be used.  
Metal parts also available in stainless steel.



Tube clamps series A (Light construction series) – Complete range

- Polypropylene – **RAP**
- Inside smooth – **RAPG**
- Polyamide 6 – **RAN**
- Inside smooth – **RANG**
- Rubber – **RAVG\***
- Aluminium – **RAA**

(As required please exchange standard abbreviation RAP in column for “Order code”)

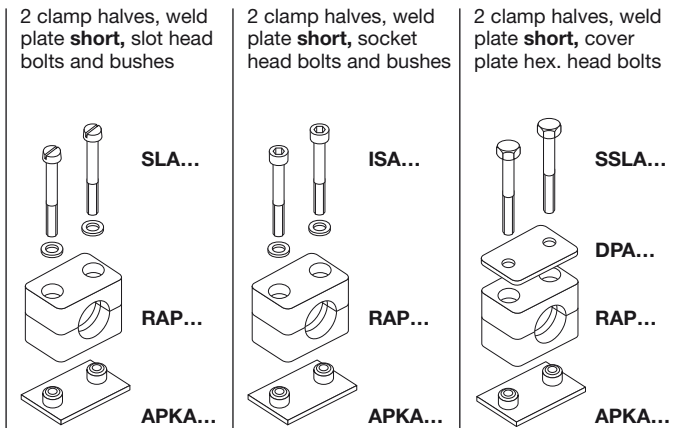

| clamp size      | Tube O.D. mm    | Tube NB         | Tube O.D.       | Order code        | Order code        | Order code        |
|-----------------|-----------------|-----------------|-----------------|-------------------|-------------------|-------------------|
| 0 <sup>1)</sup> | 6.0             | G 1/8           | 1/4             | <b>RAP1-006</b>   | <b>RAP2-006</b>   | <b>RAP3-006</b>   |
|                 | 6.4             |                 |                 | <b>RAP1-006.4</b> | <b>RAP2-006.4</b> | <b>RAP3-006.4</b> |
|                 | 8.0             |                 |                 | <b>RAP1-008</b>   | <b>RAP2-008</b>   | <b>RAP3-008</b>   |
|                 | 9.5             |                 |                 | <b>RAP1-009.5</b> | <b>RAP2-009.5</b> | <b>RAP3-009.5</b> |
|                 | 10.0            |                 |                 | <b>RAP1-010</b>   | <b>RAP2-010</b>   | <b>RAP3-010</b>   |
|                 | 12.0            |                 |                 | <b>RAP1-012</b>   | <b>RAP2-012</b>   | <b>RAP3-012</b>   |
| 1               | 6.0             | G 1/8           | 1/4             | <b>RAP1-106</b>   | <b>RAP2-106</b>   | <b>RAP3-106</b>   |
|                 | 6.4             |                 |                 | <b>RAP1-106.4</b> | <b>RAP2-106.4</b> | <b>RAP3-106.4</b> |
|                 | 8.0             |                 |                 | <b>RAP1-108</b>   | <b>RAP2-108</b>   | <b>RAP3-108</b>   |
|                 | 9.5             |                 |                 | <b>RAP1-109.5</b> | <b>RAP2-109.5</b> | <b>RAP3-109.5</b> |
|                 | 10.0            |                 |                 | <b>RAP1-110</b>   | <b>RAP2-110</b>   | <b>RAP3-110</b>   |
|                 | 12.0            |                 |                 | <b>RAP1-112</b>   | <b>RAP2-112</b>   | <b>RAP3-112</b>   |
| 2               | 12.7            | G 1/4           | 1/2             | <b>RAP1-212.7</b> | <b>RAP2-212.7</b> | <b>RAP3-212.7</b> |
|                 | 13.5            |                 |                 | <b>RAP1-213.5</b> | <b>RAP2-213.5</b> | <b>RAP3-213.5</b> |
|                 | 14.0            |                 |                 | <b>RAP1-214</b>   | <b>RAP2-214</b>   | <b>RAP3-214</b>   |
|                 | 15.0            | G 3/8           | 5/8             | <b>RAP1-215</b>   | <b>RAP2-215</b>   | <b>RAP3-215</b>   |
|                 | 16.0            |                 |                 | <b>RAP1-216</b>   | <b>RAP2-216</b>   | <b>RAP3-216</b>   |
|                 | 17.2            |                 |                 | <b>RAP1-217.2</b> | <b>RAP2-217.2</b> | <b>RAP3-217.2</b> |
| 18.0            | <b>RAP1-218</b> | <b>RAP2-218</b> | <b>RAP3-218</b> |                   |                   |                   |
| 3               | 19.0            | G 1/2           | 3/4             | <b>RAP1-319</b>   | <b>RAP2-319</b>   | <b>RAP3-319</b>   |
|                 | 20.0            |                 |                 | <b>RAP1-320</b>   | <b>RAP2-320</b>   | <b>RAP3-320</b>   |
|                 | 21.3            |                 |                 | <b>RAP1-321.3</b> | <b>RAP2-321.3</b> | <b>RAP3-321.3</b> |
|                 | 22.0            |                 |                 | <b>RAP1-322</b>   | <b>RAP2-322</b>   | <b>RAP3-322</b>   |
|                 | 23.0            |                 |                 | <b>RAP1-323</b>   | <b>RAP2-323</b>   | <b>RAP3-323</b>   |
|                 | 25.0            |                 |                 | <b>RAP1-325</b>   | <b>RAP2-325</b>   | <b>RAP3-325</b>   |
| 4               | 26.9            | G 3/4           | 1               | <b>RAP1-426.9</b> | <b>RAP2-426.9</b> | <b>RAP3-426.9</b> |
|                 | 28.0            |                 |                 | <b>RAP1-428</b>   | <b>RAP2-428</b>   | <b>RAP3-428</b>   |
|                 | 30.0            |                 |                 | <b>RAP1-430</b>   | <b>RAP2-430</b>   | <b>RAP3-430</b>   |
| 5               | 32.0            | G 1             | 1 1/4           | <b>RAP1-532</b>   | <b>RAP2-532</b>   | <b>RAP3-532</b>   |
|                 | 33.7            |                 |                 | <b>RAP1-533.7</b> | <b>RAP2-533.7</b> | <b>RAP3-533.7</b> |
|                 | 35.0            |                 |                 | <b>RAP1-535</b>   | <b>RAP2-535</b>   | <b>RAP3-535</b>   |
|                 | 38.0            | G 1 1/4         | 1 1/2           | <b>RAP1-538</b>   | <b>RAP2-538</b>   | <b>RAP3-538</b>   |
|                 | 40.0            |                 |                 | <b>RAP1-540</b>   | <b>RAP2-540</b>   | <b>RAP3-540</b>   |
|                 | 42.0            |                 |                 | <b>RAP1-542</b>   | <b>RAP2-542</b>   | <b>RAP3-542</b>   |
| 6               | 44.5            | G 1 1/2         | 1 3/4           | <b>RAP1-644.5</b> | <b>RAP2-644.5</b> | <b>RAP3-644.5</b> |
|                 | 45.0            |                 |                 | <b>RAP1-645</b>   | <b>RAP2-645</b>   | <b>RAP3-645</b>   |
|                 | 48.0            |                 |                 | <b>RAP1-648</b>   | <b>RAP2-648</b>   | <b>RAP3-648</b>   |
|                 | 50.0            | 2               | 2               | <b>RAP1-650</b>   | <b>RAP2-650</b>   | <b>RAP3-650</b>   |
|                 | 50.8            |                 |                 | <b>RAP1-650.8</b> | <b>RAP2-650.8</b> | <b>RAP3-650.8</b> |
|                 | 52.0            |                 |                 | <b>RAP1-652</b>   | <b>RAP2-652</b>   | <b>RAP3-652</b>   |
|                 | 55.0            |                 |                 | <b>RAP1-655</b>   | <b>RAP2-655</b>   | <b>RAP3-655</b>   |
|                 | 57.0            |                 |                 | <b>RAP1-657</b>   | <b>RAP2-657</b>   | <b>RAP3-657</b>   |
|                 |                 |                 |                 |                   |                   |                   |

Delivery in unassembled individual components.

<sup>1)</sup> Contrary to the illustration size 0 clamps are secured by only one screw.

\* Only with cover plate, hexagon screws and locking washers.

## Tube clamps

### Tube clamps series A (Light construction series) – Complete range

Polypropylene – **RAP**  
 Inside smooth – **RAPG**  
 Polyamide 6 – **RAN**  
 Inside smooth – **RANG**  
 Rubber – **RAVG\***  
 Aluminium – **RAA**

(As required please exchange standard abbreviation RAP in column for “Order code”)

2 clamp halves, weld/  
screw plate, slot head  
bolts and bushes

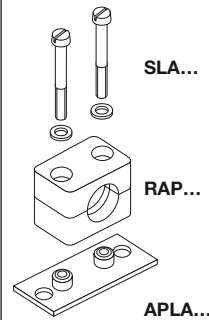

2 clamp halves, weld/  
screw plate, socket  
head bolts and bushes

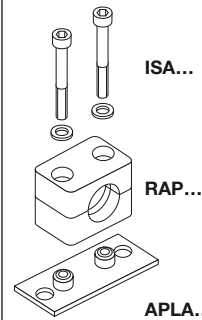

2 clamp halves, weld/  
screw plate, cover pla-  
te and hex. head bolts

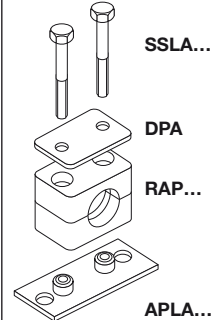

| clamp size      | Tube O.D. mm    | Tube NB         | Tube O.D.       | Order code        | Order code        | Order code        |
|-----------------|-----------------|-----------------|-----------------|-------------------|-------------------|-------------------|
| 0 <sup>1)</sup> | 6.0             | G 1/8           | 1/4             | <b>RAP4-006</b>   | <b>RAP5-006</b>   | <b>RAP6-006</b>   |
|                 | 6.4             |                 |                 | <b>RAP4-006.4</b> | <b>RAP5-006.4</b> | <b>RAP6-006.4</b> |
|                 | 8.0             |                 |                 | <b>RAP4-008</b>   | <b>RAP5-008</b>   | <b>RAP6-008</b>   |
|                 | 9.5             |                 |                 | <b>RAP4-009.5</b> | <b>RAP5-009.5</b> | <b>RAP6-009.5</b> |
|                 | 10.0            |                 |                 | <b>RAP4-010</b>   | <b>RAP5-010</b>   | <b>RAP6-010</b>   |
|                 | 12.0            |                 |                 | <b>RAP4-012</b>   | <b>RAP5-012</b>   | <b>RAP6-012</b>   |
| 1               | 6.0             | G 1/8           | 1/4             | <b>RAP4-106</b>   | <b>RAP5-106</b>   | <b>RAP6-106</b>   |
|                 | 6.4             |                 |                 | <b>RAP4-106.4</b> | <b>RAP5-106.4</b> | <b>RAP6-106.4</b> |
|                 | 8.0             |                 |                 | <b>RAP4-108</b>   | <b>RAP5-108</b>   | <b>RAP6-108</b>   |
|                 | 9.5             |                 |                 | <b>RAP4-109.5</b> | <b>RAP5-109.5</b> | <b>RAP6-109.5</b> |
|                 | 10.0            |                 |                 | <b>RAP4-110</b>   | <b>RAP5-110</b>   | <b>RAP6-110</b>   |
|                 | 12.0            |                 |                 | <b>RAP4-112</b>   | <b>RAP5-112</b>   | <b>RAP6-112</b>   |
| 2               | 12.7            | G 1/4           | 1/2             | <b>RAP4-212.7</b> | <b>RAP5-212.7</b> | <b>RAP6-212.7</b> |
|                 | 13.5            |                 |                 | <b>RAP4-213.5</b> | <b>RAP5-213.5</b> | <b>RAP6-213.5</b> |
|                 | 14.0            |                 |                 | <b>RAP4-214</b>   | <b>RAP5-214</b>   | <b>RAP6-214</b>   |
|                 | 15.0            | G 3/8           | 5/8             | <b>RAP4-215</b>   | <b>RAP5-215</b>   | <b>RAP6-215</b>   |
|                 | 16.0            |                 |                 | <b>RAP4-216</b>   | <b>RAP5-216</b>   | <b>RAP6-216</b>   |
|                 | 17.2            |                 |                 | <b>RAP4-217.2</b> | <b>RAP5-217.2</b> | <b>RAP6-217.2</b> |
| 18.0            | <b>RAP4-218</b> | <b>RAP5-218</b> | <b>RAP6-218</b> |                   |                   |                   |
| 3               | 19.0            | G 1/2           | 3/4             | <b>RAP4-319</b>   | <b>RAP5-319</b>   | <b>RAP6-319</b>   |
|                 | 20.0            |                 |                 | <b>RAP4-320</b>   | <b>RAP5-320</b>   | <b>RAP6-320</b>   |
|                 | 21.3            |                 |                 | <b>RAP4-321.3</b> | <b>RAP5-321.3</b> | <b>RAP6-321.3</b> |
|                 | 22.0            |                 |                 | <b>RAP4-322</b>   | <b>RAP5-322</b>   | <b>RAP6-322</b>   |
|                 | 23.0            |                 |                 | <b>RAP4-323</b>   | <b>RAP5-323</b>   | <b>RAP6-323</b>   |
|                 | 25.0            |                 |                 | <b>RAP4-325</b>   | <b>RAP5-325</b>   | <b>RAP6-325</b>   |
| 4               | 26.9            | G 3/4           | 1               | <b>RAP4-426.9</b> | <b>RAP5-426.9</b> | <b>RAP6-426.9</b> |
|                 | 28.0            |                 |                 | <b>RAP4-428</b>   | <b>RAP5-428</b>   | <b>RAP6-428</b>   |
|                 | 30.0            |                 |                 | <b>RAP4-430</b>   | <b>RAP5-430</b>   | <b>RAP6-430</b>   |
| 5               | 32.0            | G 1             | 1 1/4           | <b>RAP4-532</b>   | <b>RAP5-532</b>   | <b>RAP6-532</b>   |
|                 | 33.7            |                 |                 | <b>RAP4-533.7</b> | <b>RAP5-533.7</b> | <b>RAP6-533.7</b> |
|                 | 35.0            |                 |                 | <b>RAP4-535</b>   | <b>RAP5-535</b>   | <b>RAP6-535</b>   |
|                 | 38.0            | G 1 1/4         | 1 1/2           | <b>RAP4-538</b>   | <b>RAP5-538</b>   | <b>RAP6-538</b>   |
|                 | 40.0            |                 |                 | <b>RAP4-540</b>   | <b>RAP5-540</b>   | <b>RAP6-540</b>   |
|                 | 42.0            |                 |                 | <b>RAP4-542</b>   | <b>RAP5-542</b>   | <b>RAP6-542</b>   |
| 6               | 44.5            | G 1 1/2         | 1 3/4           | <b>RAP4-644.5</b> | <b>RAP5-644.5</b> | <b>RAP6-644.5</b> |
|                 | 45.0            |                 |                 | <b>RAP4-645</b>   | <b>RAP5-645</b>   | <b>RAP6-645</b>   |
|                 | 48.0            |                 |                 | <b>RAP4-648</b>   | <b>RAP5-648</b>   | <b>RAP6-648</b>   |
|                 | 50.0            | 2               | 2               | <b>RAP4-650</b>   | <b>RAP5-650</b>   | <b>RAP6-650</b>   |
|                 | 50.8            |                 |                 | <b>RAP4-650.8</b> | <b>RAP5-650.8</b> | <b>RAP6-650.8</b> |
|                 | 52.0            |                 |                 | <b>RAP4-652</b>   | <b>RAP5-652</b>   | <b>RAP6-652</b>   |
|                 | 55.0            |                 |                 | <b>RAP4-655</b>   | <b>RAP5-655</b>   | <b>RAP6-655</b>   |
|                 | 57.0            |                 |                 | <b>RAP4-657</b>   | <b>RAP5-657</b>   | <b>RAP6-657</b>   |
|                 |                 |                 |                 | 2 1/4             |                   |                   |

Delivery in unassembled individual components.

<sup>1)</sup> Contrary to the illustration size 0 clamps are secured by only one screw.

\* Only with cover plate, hexagon screws and locking washers.



**Tube clamps series A (Light construction series) – Complete range**

Polypropylene – **RAP**  
 Inside smooth – **RAPG**  
 Polyamide 6 – **RAN**  
 Inside smooth – **RANG**  
 Rubber – **RAVG\***  
 Aluminium – **RAA**

(As required please exchange standard abbreviation RAP in column for “Order code”)

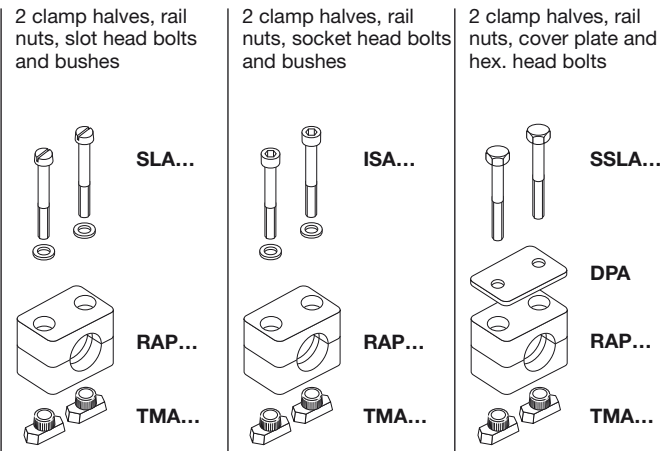

| clamp size      | Tube O.D. mm    | Tube NB          | Tube O.D.        | Order code        | Order code         | Order code         |
|-----------------|-----------------|------------------|------------------|-------------------|--------------------|--------------------|
| 0 <sup>1)</sup> | 6.0             | G 1/8            | 1/4              | <b>RAP9-006</b>   | <b>RAP10-006</b>   | <b>RAP12-006</b>   |
|                 | 6.4             |                  |                  | <b>RAP9-006.4</b> | <b>RAP10-006.4</b> | <b>RAP12-006.4</b> |
|                 | 8.0             |                  |                  | <b>RAP9-008</b>   | <b>RAP10-008</b>   | <b>RAP12-008</b>   |
|                 | 9.5             |                  |                  | <b>RAP9-009.5</b> | <b>RAP10-009.5</b> | <b>RAP12-009.5</b> |
|                 | 10.0            |                  |                  | <b>RAP9-010</b>   | <b>RAP10-010</b>   | <b>RAP12-010</b>   |
|                 | 12.0            |                  |                  | <b>RAP9-012</b>   | <b>RAP10-012</b>   | <b>RAP12-012</b>   |
| 1               | 6.0             | G 1/8            | 1/4              | <b>RAP9-106</b>   | <b>RAP10-106</b>   | <b>RAP12-106</b>   |
|                 | 6.4             |                  |                  | <b>RAP9-106.4</b> | <b>RAP10-106.4</b> | <b>RAP12-106.4</b> |
|                 | 8.0             |                  |                  | <b>RAP9-108</b>   | <b>RAP10-108</b>   | <b>RAP12-108</b>   |
|                 | 9.5             |                  |                  | <b>RAP9-109.5</b> | <b>RAP10-109.5</b> | <b>RAP12-109.5</b> |
|                 | 10.0            |                  |                  | <b>RAP9-110</b>   | <b>RAP10-110</b>   | <b>RAP12-110</b>   |
|                 | 12.0            |                  |                  | <b>RAP9-112</b>   | <b>RAP10-112</b>   | <b>RAP12-112</b>   |
| 2               | 12.7            | G 1/4            | 1/2              | <b>RAP9-212.7</b> | <b>RAP10-212.7</b> | <b>RAP12-212.7</b> |
|                 | 13.5            |                  |                  | <b>RAP9-213.5</b> | <b>RAP10-213.5</b> | <b>RAP12-213.5</b> |
|                 | 14.0            |                  |                  | <b>RAP9-214</b>   | <b>RAP10-214</b>   | <b>RAP12-214</b>   |
|                 | 15.0            | G 3/8            | 5/8              | <b>RAP9-215</b>   | <b>RAP10-215</b>   | <b>RAP12-215</b>   |
|                 | 16.0            |                  |                  | <b>RAP9-216</b>   | <b>RAP10-216</b>   | <b>RAP12-216</b>   |
|                 | 17.2            |                  |                  | <b>RAP9-217.2</b> | <b>RAP10-217.2</b> | <b>RAP12-217.2</b> |
| 18.0            | <b>RAP9-218</b> | <b>RAP10-218</b> | <b>RAP12-218</b> |                   |                    |                    |
| 3               | 19.0            | G 1/2            | 3/4              | <b>RAP9-319</b>   | <b>RAP10-319</b>   | <b>RAP12-319</b>   |
|                 | 20.0            |                  |                  | <b>RAP9-320</b>   | <b>RAP10-320</b>   | <b>RAP12-320</b>   |
|                 | 21.3            |                  |                  | <b>RAP9-321.3</b> | <b>RAP10-321.3</b> | <b>RAP12-321.3</b> |
|                 | 22.0            |                  |                  | <b>RAP9-322</b>   | <b>RAP10-322</b>   | <b>RAP12-322</b>   |
|                 | 23.0            |                  |                  | <b>RAP9-323</b>   | <b>RAP10-323</b>   | <b>RAP12-323</b>   |
|                 | 25.0            |                  |                  | <b>RAP9-325</b>   | <b>RAP10-325</b>   | <b>RAP12-325</b>   |
| 4               | 26.9            | G 3/4            | 1                | <b>RAP9-426.9</b> | <b>RAP10-426.9</b> | <b>RAP12-426.9</b> |
|                 | 28.0            |                  |                  | <b>RAP9-428</b>   | <b>RAP10-428</b>   | <b>RAP12-428</b>   |
|                 | 30.0            |                  |                  | <b>RAP9-430</b>   | <b>RAP10-430</b>   | <b>RAP12-430</b>   |
| 5               | 32.0            | G 1              | 1 1/4            | <b>RAP9-532</b>   | <b>RAP10-532</b>   | <b>RAP12-532</b>   |
|                 | 33.7            |                  |                  | <b>RAP9-533.7</b> | <b>RAP10-533.7</b> | <b>RAP12-533.7</b> |
|                 | 35.0            |                  |                  | <b>RAP9-535</b>   | <b>RAP10-535</b>   | <b>RAP12-535</b>   |
|                 | 38.0            | G 1 1/4          | 1 1/2            | <b>RAP9-538</b>   | <b>RAP10-538</b>   | <b>RAP12-538</b>   |
|                 | 40.0            |                  |                  | <b>RAP9-540</b>   | <b>RAP10-540</b>   | <b>RAP12-540</b>   |
|                 | 42.0            |                  |                  | <b>RAP9-542</b>   | <b>RAP10-542</b>   | <b>RAP12-542</b>   |
| 6               | 44.5            | G 1 1/2          | 1 3/4            | <b>RAP9-644.5</b> | <b>RAP10-644.5</b> | <b>RAP12-644.5</b> |
|                 | 45.0            |                  |                  | <b>RAP9-645</b>   | <b>RAP10-645</b>   | <b>RAP12-645</b>   |
|                 | 48.0            |                  |                  | <b>RAP9-648</b>   | <b>RAP10-648</b>   | <b>RAP12-648</b>   |
|                 | 50.0            | 2                | 2                | <b>RAP9-650</b>   | <b>RAP10-650</b>   | <b>RAP12-650</b>   |
|                 | 50.8            |                  |                  | <b>RAP9-650.8</b> | <b>RAP10-650.8</b> | <b>RAP12-650.8</b> |
|                 | 52.0            |                  |                  | <b>RAP9-652</b>   | <b>RAP10-652</b>   | <b>RAP12-652</b>   |
|                 | 55.0            |                  |                  | <b>RAP9-655</b>   | <b>RAP10-655</b>   | <b>RAP12-655</b>   |
|                 | 57.0            |                  |                  | <b>RAP9-657</b>   | <b>RAP10-657</b>   | <b>RAP12-657</b>   |
|                 |                 |                  |                  |                   |                    |                    |

**Delivery in unassembled individual components.**

<sup>1)</sup> Contrary to the illustration size 0 clamps are secured by only one screw.

\* Only with cover plate, hexagon screws and locking washers.

## Tube clamps

### Tube clamps series A – Complete range

Polypropylene – **RAP**  
 Inside smooth – **RAPG**  
 Polyamide 6 – **RAN**  
 Inside smooth – **RANG**  
 Rubber – **RAVG\***  
 Aluminium – **RAA**

(As required please exchange standard abbreviation RAP in column for “Order code”)

2 clamp halves, slot heads and bushes

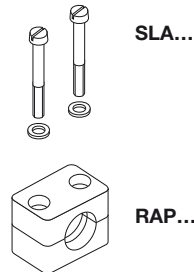

2 clamp halves, socket head bolts and bushes

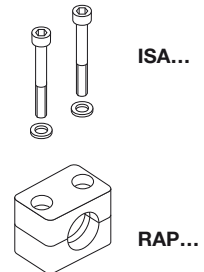

| clamp size      | Tube O.D. mm     | Tube NB          | Tube O.D. | Order code         | Order code         |
|-----------------|------------------|------------------|-----------|--------------------|--------------------|
| 0 <sup>1)</sup> | 6.0              | G 1/8            | 1/4       | <b>RAP13-006</b>   | <b>RAP14-006</b>   |
|                 | 6.4              |                  |           | <b>RAP13-006.4</b> | <b>RAP14-006.4</b> |
|                 | 8.0              |                  |           | <b>RAP13-008</b>   | <b>RAP14-008</b>   |
|                 | 9.5              |                  |           | <b>RAP13-009.5</b> | <b>RAP14-009.5</b> |
|                 | 10.0             |                  |           | <b>RAP13-010</b>   | <b>RAP14-010</b>   |
|                 | 12.0             |                  |           | <b>RAP13-012</b>   | <b>RAP14-012</b>   |
| 1               | 6.0              | G 1/8            | 1/4       | <b>RAP13-106</b>   | <b>RAP14-106</b>   |
|                 | 6.4              |                  |           | <b>RAP13-106.4</b> | <b>RAP14-106.4</b> |
|                 | 8.0              |                  |           | <b>RAP13-108</b>   | <b>RAP14-108</b>   |
|                 | 9.5              |                  |           | <b>RAP13-109.5</b> | <b>RAP14-109.5</b> |
|                 | 10.0             |                  |           | <b>RAP13-110</b>   | <b>RAP14-110</b>   |
|                 | 12.0             |                  |           | <b>RAP13-112</b>   | <b>RAP14-112</b>   |
| 2               | 12.7             | G 1/4            | 1/2       | <b>RAP13-212.7</b> | <b>RAP14-212.7</b> |
|                 | 13.5             |                  |           | <b>RAP13-213.5</b> | <b>RAP14-213.5</b> |
|                 | 14.0             |                  |           | <b>RAP13-214</b>   | <b>RAP14-214</b>   |
|                 | 15.0             | G 3/8            | 5/8       | <b>RAP13-215</b>   | <b>RAP14-215</b>   |
|                 | 16.0             |                  |           | <b>RAP13-216</b>   | <b>RAP14-216</b>   |
|                 | 17.2             |                  |           | <b>RAP13-217.2</b> | <b>RAP14-217.2</b> |
| 18.0            | <b>RAP13-218</b> | <b>RAP14-218</b> |           |                    |                    |
| 3               | 19.0             | G 1/2            | 3/4       | <b>RAP13-319</b>   | <b>RAP14-319</b>   |
|                 | 20.0             |                  |           | <b>RAP13-320</b>   | <b>RAP14-320</b>   |
|                 | 21.3             |                  |           | <b>RAP13-321.3</b> | <b>RAP14-321.3</b> |
|                 | 22.0             |                  | 1         | <b>RAP13-322</b>   | <b>RAP14-322</b>   |
|                 | 23.0             |                  |           | <b>RAP13-323</b>   | <b>RAP14-323</b>   |
|                 | 25.0             |                  |           | <b>RAP13-325</b>   | <b>RAP14-325</b>   |
| 4               | 26.9             | G 3/4            |           | <b>RAP13-426.9</b> | <b>RAP14-426.9</b> |
|                 | 28.0             |                  |           | <b>RAP13-428</b>   | <b>RAP14-428</b>   |
|                 | 30.0             |                  |           | <b>RAP13-430</b>   | <b>RAP14-430</b>   |
| 5               | 32.0             | G 1              | 1 1/4     | <b>RAP13-532</b>   | <b>RAP14-532</b>   |
|                 | 33.7             |                  |           | <b>RAP13-533.7</b> | <b>RAP14-533.7</b> |
|                 | 35.0             |                  |           | <b>RAP13-535</b>   | <b>RAP14-535</b>   |
|                 | 38.0             | G 1 1/4          | 1 1/2     | <b>RAP13-538</b>   | <b>RAP14-538</b>   |
|                 | 40.0             |                  |           | <b>RAP13-540</b>   | <b>RAP14-540</b>   |
|                 | 42.0             |                  |           | <b>RAP13-542</b>   | <b>RAP14-542</b>   |
| 6               | 44.5             | G 1 1/2          | 1 3/4     | <b>RAP13-644.5</b> | <b>RAP14-644.5</b> |
|                 | 45.0             |                  |           | <b>RAP13-645</b>   | <b>RAP14-645</b>   |
|                 | 48.0             |                  |           | <b>RAP13-648</b>   | <b>RAP14-648</b>   |
|                 | 50.0             | 2                | 2         | <b>RAP13-650</b>   | <b>RAP14-650</b>   |
|                 | 50.8             |                  |           | <b>RAP13-650.8</b> | <b>RAP14-650.8</b> |
|                 | 52.0             |                  |           | <b>RAP13-652</b>   | <b>RAP14-652</b>   |
|                 | 55.0             |                  |           | <b>RAP13-655</b>   | <b>RAP14-655</b>   |
|                 | 57.0             |                  |           | <b>RAP13-657</b>   | <b>RAP14-657</b>   |
|                 |                  |                  |           |                    | 2 1/4              |

#### Delivery in unassembled individual components.

<sup>1)</sup> Contrary to the illustration size 0 clamps are secured by only one screw.

\* Only with cover plate, hexagon screws and locking washers.



Tube clamps series A – Complete range

- Polypropylene – **RAP**
- Inside smooth – **RAPG**
- Polyamide 6 – **RAN**
- Inside smooth – **RANG**
- Rubber – **RAVG\***
- Aluminium – **RAA**

(As required please exchange standard abbreviation RAP in column for “Order code”)

2 clamp halves, cover plate and hex. head bolts

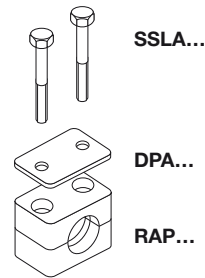

2 clamp halves, stacking bolts and locking plate

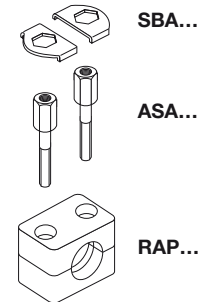

| clamp size      | Tube O.D. mm     | Tube NB          | Tube O.D. | Order code         | Order code         |
|-----------------|------------------|------------------|-----------|--------------------|--------------------|
| 0 <sup>1)</sup> | 6.0              | G 1/8            | 1/4       | <b>RAP16-006</b>   | <b>RAP18-006</b>   |
|                 | 6.4              |                  |           | <b>RAP16-006.4</b> | <b>RAP18-006.4</b> |
|                 | 8.0              |                  |           | <b>RAP16-008</b>   | <b>RAP18-008</b>   |
|                 | 9.5              |                  |           | <b>RAP16-009.5</b> | <b>RAP18-009.5</b> |
|                 | 10.0             |                  |           | <b>RAP16-010</b>   | <b>RAP18-010</b>   |
|                 | 12.0             |                  |           | <b>RAP16-012</b>   | <b>RAP18-012</b>   |
| 1               | 6.0              | G 1/8            | 1/4       | <b>RAP16-106</b>   | <b>RAP18-106</b>   |
|                 | 6.4              |                  |           | <b>RAP16-106.4</b> | <b>RAP18-106.4</b> |
|                 | 8.0              |                  |           | <b>RAP16-108</b>   | <b>RAP18-108</b>   |
|                 | 9.5              |                  |           | <b>RAP16-109.5</b> | <b>RAP18-109.5</b> |
|                 | 10.0             |                  |           | <b>RAP16-110</b>   | <b>RAP18-110</b>   |
|                 | 12.0             |                  |           | <b>RAP16-112</b>   | <b>RAP18-112</b>   |
| 2               | 12.7             | G 1/4            | 1/2       | <b>RAP16-212.7</b> | <b>RAP18-212.7</b> |
|                 | 13.5             |                  |           | <b>RAP16-213.5</b> | <b>RAP18-213.5</b> |
|                 | 14.0             |                  |           | <b>RAP16-214</b>   | <b>RAP18-214</b>   |
|                 | 15.0             | G 3/8            | 5/8       | <b>RAP16-215</b>   | <b>RAP18-215</b>   |
|                 | 16.0             |                  |           | <b>RAP16-216</b>   | <b>RAP18-216</b>   |
|                 | 17.2             |                  |           | <b>RAP16-217.2</b> | <b>RAP18-217.2</b> |
| 18.0            | <b>RAP16-218</b> | <b>RAP18-218</b> |           |                    |                    |
| 3               | 19.0             | G 1/2            | 3/4       | <b>RAP16-319</b>   | <b>RAP18-319</b>   |
|                 | 20.0             |                  |           | <b>RAP16-320</b>   | <b>RAP18-320</b>   |
|                 | 21.3             |                  |           | <b>RAP16-321.3</b> | <b>RAP18-321.3</b> |
|                 | 22.0             |                  | 1         | <b>RAP16-322</b>   | <b>RAP18-322</b>   |
|                 | 23.0             |                  |           | <b>RAP16-323</b>   | <b>RAP18-323</b>   |
|                 | 25.0             |                  |           | <b>RAP16-325</b>   | <b>RAP18-325</b>   |
| 4               | 26.9             | G 3/4            |           | <b>RAP16-426.9</b> | <b>RAP18-426.9</b> |
|                 | 28.0             |                  |           | <b>RAP16-428</b>   | <b>RAP18-428</b>   |
|                 | 30.0             |                  |           | <b>RAP16-430</b>   | <b>RAP18-430</b>   |
| 5               | 32.0             | G 1              | 1 1/4     | <b>RAP16-532</b>   | <b>RAP18-532</b>   |
|                 | 33.7             |                  |           | <b>RAP16-533.7</b> | <b>RAP18-533.7</b> |
|                 | 35.0             |                  |           | <b>RAP16-535</b>   | <b>RAP18-535</b>   |
|                 | 38.0             | G 1 1/4          | 1 1/2     | <b>RAP16-538</b>   | <b>RAP18-538</b>   |
|                 | 40.0             |                  |           | <b>RAP16-540</b>   | <b>RAP18-540</b>   |
|                 | 42.0             |                  |           | <b>RAP16-542</b>   | <b>RAP18-542</b>   |
| 6               | 44.5             | G 1 1/2          | 1 3/4     | <b>RAP16-644.5</b> | <b>RAP18-644.5</b> |
|                 | 45.0             |                  |           | <b>RAP16-645</b>   | <b>RAP18-645</b>   |
|                 | 48.0             |                  |           | <b>RAP16-648</b>   | <b>RAP18-648</b>   |
|                 | 50.0             |                  |           | <b>RAP16-650</b>   | <b>RAP18-650</b>   |
|                 | 50.8             | 2                |           | <b>RAP16-650.8</b> | <b>RAP18-650.8</b> |
|                 | 52.0             |                  |           | <b>RAP16-652</b>   | <b>RAP18-652</b>   |
|                 | 55.0             |                  |           | <b>RAP16-655</b>   | <b>RAP18-655</b>   |
|                 | 57.0             |                  |           | <b>RAP16-657</b>   | <b>RAP18-657</b>   |
|                 |                  |                  | 2 1/4     |                    |                    |

**Delivery in unassembled individual components.**

<sup>1)</sup> Contrary to the illustration size 0 clamps are secured by only one screw.

\* Only with cover plate, hexagon screws and locking washers.

## Tube clamps

### Tube clamps series B (Twin-tube clamps) – Components

DIN 3015, part 3

#### Order code for clamp halves:

Polypropylene – **RBP**  
 Inside smooth – **RBPG**  
 Polyamide 6 – **RBN**  
 Rubber – **RBVG**

(Please exchange standard abbreviation RBP in column for “clamp halves” as required.)

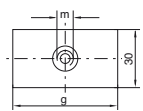
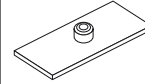
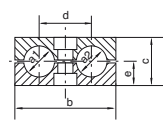
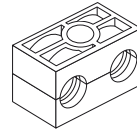

Width: 30 mm

| clamp size | Tube O.D. mm | Tube NB | Tube O.D. | 1 part<br>2 clamp halves <sup>1)</sup> |                        |    |    |      | weld plate           |                    |                    |
|------------|--------------|---------|-----------|--|------------------------|----|----|------|----------------------|--------------------|--------------------|
|            |              |         |           | RBP...<br>Order code                   | dimensions:<br>b c d e |    |    |      | APB...<br>Order code | dimensions:<br>g m |                    |
| 1          | 6.0          | G 1/8   | 1/4       | <b>RBP106X</b>                         | 36                     | 27 | 20 | 13.5 | <b>APB1X</b>         | 37                 | M 6                |
|            | 6.4          |         |           |  |                        |    |    |      |                      |                    |                    |
|            | 8.0          |         |           |  |                        |    |    |      |                      |                    |                    |
|            | 9.5          |         |           |  |                        |    |    |      |                      |                    |                    |
|            | 10.0         |         |           |  |                        |    |    |      |                      |                    |                    |
| 12.0       |              |         |           |  |                        |    |    |      |                      |                    | Thickness:<br>3 mm |
| 2          | 12.7         | G 1/4   | 1/2       | <b>RBP212.7X</b>                       | 53                     | 26 | 29 | 13   | <b>APB2X</b>         | 55                 | M 8                |
|            | 13.5         |         |           |  |                        |    |    |      |                      |                    |                    |
|            | 14.0         |         |           |  |                        |    |    |      |                      |                    |                    |
|            | 15.0         |         |           |  |                        |    |    |      |                      |                    |                    |
|            | 16.0         |         |           |  |                        |    |    |      |                      |                    |                    |
| 17.2       | G 3/8        | 5/8     |           |  |                        |    |    |      |                      |                    | Thickness:<br>5 mm |
| 3          | 19.0         | G 1/2   | 3/4       | <b>RBP319X</b>                         | 67                     | 37 | 36 | 18.5 | <b>APB3X</b>         | 70                 | M 8                |
|            | 20.0         |         |           |  |                        |    |    |      |                      |                    |                    |
|            | 21.3         |         |           |  |                        |    |    |      |                      |                    |                    |
|            | 22.0         |         |           |  |                        |    |    |      |                      |                    |                    |
|            | 25.0         |         |           |  |                        |    |    |      |                      |                    |                    |
| 4          | 26.9         | G 3/4   |           | <b>RBP426.9X</b>                       | 82                     | 42 | 45 | 21   | <b>APB4X</b>         | 85                 | M 8                |
|            | 28.0         |         |           |  |                        |    |    |      |                      |                    |                    |
|            | 30.0         |         |           |  |                        |    |    |      |                      |                    |                    |
| 5          | 32.0         | G 1     | 1 1/4     | <b>RBP532X</b>                         | 106                    | 54 | 56 | 27   | <b>APB5X</b>         | 110                | M 8                |
|            | 33.7         |         |           |  |                        |    |    |      |                      |                    |                    |
|            | 35.0         |         |           |  |                        |    |    |      |                      |                    |                    |
|            | 38.0         |         |           |  |                        |    |    |      |                      |                    |                    |
|            | 42.0         |         |           |  |                        |    |    |      |                      |                    |                    |

Metal parts also available in stainless steel.

<sup>1)</sup> Twin-tube clamps with different outer tube diameters upon request.

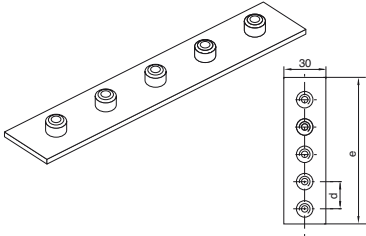
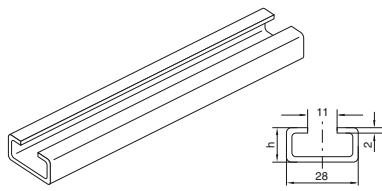
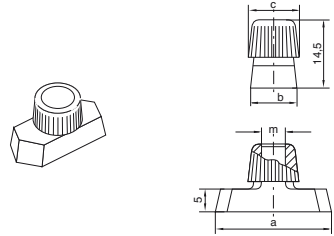

**Tube clamps series B (Twin-tube clamps) – Components**

DIN 3015, part 3

|            |  |                                  |                                    |                                  |  |                        |
|------------|---|----------------------------------|--|----------------------------------|---|------------------------|
|            |   |                                  | 1 or 2 mtr   |                                  |   |                        |
| clamp size | multiple weld plate<br>APRB...<br>Order code                                      | dimensions:<br>d e<br>Thickness: | mounting rail<br>TS... A/B<br>Order code   | dimensions:<br>h                 | rail nut<br>TM...<br>Order code   | dimensions:<br>a b c m |
| 1          | <b>APRB1X</b><br>(5 clamps)   | 40 196<br>Thickness: 3 mm        | <b>TS11A/B1X</b><br><b>TS11A/B2X</b><br><b>TS14A/B1X</b><br><b>TS14A/B2X</b><br><b>TS30A/B1X</b><br><b>TS30A/B2X</b> | TS11: 11<br>TS14: 14<br>TS30: 30 | <b>TMA/TMB1VERZX</b>  | 25.4 10.4 12 M 6       |
| 2          | <b>APRB2X</b><br>(5 clamps)   | 58 288<br>Thickness: 5 mm        |  |                                  | <b>TMB2X</b>  | 25.4 10.4 12 M8        |
| 3          | <b>APRB3X</b><br>(5 clamps)   | 72 358<br>Thickness: 5 mm        |  |                                  |   |                        |
| 4          | <b>APRB4X</b><br>(5 clamps)   | 90 446<br>Thickness: 5 mm        |  |                                  |   |                        |
| 5          | <b>APRB5X</b><br>(5 clamps)   | 112 558<br>Thickness: 5 mm       |  |                                  |   |                        |

**Tube clamps series B (Twin-tube clamps) – Components**

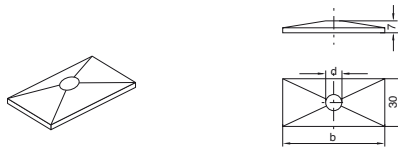
DIN 3015, part 3

|            |  |                    |  |                      |
|------------|---|--------------------|---|----------------------|
|            |   |                    | DIN 931/933   |                      |
| clamp size | cover plate<br>DP B...<br>Order code  | dimensions:<br>b d | hexagonal head<br>SS B...<br>Order code   | dimensions:<br>d x L |
| 1          | <b>DPB1X</b>  | 34 6.6             | <b>SSLA2/SSB1X</b>  | M 6 x 35             |
| 2          | <b>DPB2X</b>  | 51 8.6             | <b>SSB2X</b>  | M 8 x 35             |
| 3          | <b>DPB3X</b>  | 64 8.6             | <b>SSB3X</b>  | M 8 x 45             |
| 4          | <b>DPB4X</b>  | 78 8.6             | <b>SSB4X</b>  | M 8 x 50             |
| 5          | <b>DPB5X</b>  | 102 8.6            | <b>SSB5X</b>  | M 8 x 60             |

Metal parts also available in stainless steel.

## Tube clamps

### Tube clamps series B (Twin-tube clamps) – Components

DIN 3015, part 3

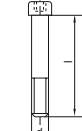

DIN 912

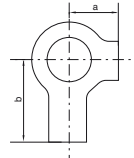
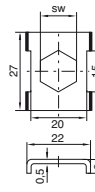
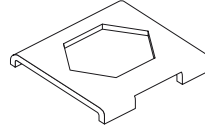
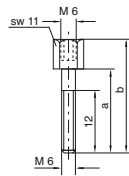

| clamp size | socket head              |                      | stacking                 |             |    |     | locking plate <sup>1)</sup> |                   | locking washer <sup>2)</sup> |                    |    |    |
|------------|--------------------------|----------------------|--------------------------|-------------|----|-----|-----------------------------|-------------------|------------------------------|--------------------|----|----|
|            | IS B...<br>Order code    | dimensions:<br>d × L | AS B...<br>Order code    | dimensions: |    |     | SB B...<br>Order code       | dimensions:<br>SW | US...<br>Order code          | dimensions:<br>a b |    |    |
| 1          | <b>ISA4X<br/>(ISB1X)</b> | M 6 × 35             | <b>ASA0X<br/>(ASB1X)</b> | 20          | 34 | M 6 | 11                          | <b>SBB1X</b>      | 11                           | <b>USA/USB1X</b>   | 9  | 18 |
| 2          | <b>ISB2X</b>             | M 8 × 35             | <b>ASB2X</b>             | 20          | 33 | M 8 | 12                          | <b>SBB2X</b>      | 12                           | <b>USB2X</b>       | 11 | 20 |
| 3          | <b>ISB3X</b>             | M 8 × 45             | <b>ASB3X</b>             | 29          | 44 | M 8 | 12                          |                   |                              |                    |    |    |
| 4          | <b>ISB4X</b>             | M 8 × 50             | <b>ASB4X</b>             | 34          | 49 | M 8 | 12                          |                   |                              |                    |    |    |
| 5          | <b>ISB5X</b>             | M 8 × 60             | <b>ASB5X</b>             | 47          | 62 | M 8 | 12                          |                   |                              |                    |    |    |

<sup>1)</sup> The use of stacking screws necessitates the use of locking plates in the construction assembly!

<sup>2)</sup> When assembling solid rubber clamps, covering plates, hexagon screws and locking washers must be used. Metal parts also available in stainless steel.



Tube clamps series B – Complete range

Polypropylene – **RBP**  
 Inside smooth – **RBPG**  
 Polyamide 6 – **RBN**  
 Rubber – **RBVG\***

(As required please exchange standard abbreviation RBP in column for "Order code")

2 clamp halves, weld plate, cover plate, hex. head bolt

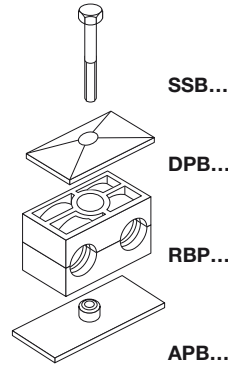

2 clamp halves, weld plate, cover plate, socket head bolt

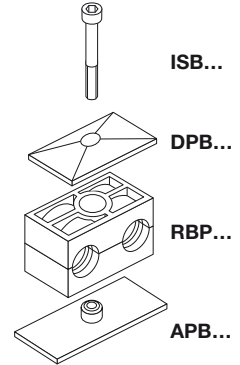

| clamp size | Tube O.D. mm    | Tube NB                       | Tube O.D. | Order code                    | Order code        |
|------------|-----------------|-------------------------------|-----------|-------------------------------|-------------------|
| 1          | 6.0             | G <sup>1</sup> / <sub>8</sub> | 1/4       | <b>RBP1-106</b>               | <b>RBP3-106</b>   |
|            | 6.4             |                               |           | <b>RBP1-106.4</b>             | <b>RBP3-106.4</b> |
|            | 8.0             |                               |           | <b>RBP1-108</b>               | <b>RBP3-108</b>   |
|            | 9.5             |                               |           | <b>RBP1-109.5</b>             | <b>RBP3-109.5</b> |
|            | 10.0            |                               |           | <b>RBP1-110</b>               | <b>RBP3-110</b>   |
|            | 12.0            |                               |           | <b>RBP1-112</b>               | <b>RBP3-112</b>   |
| 2          | 12.7            | G <sup>1</sup> / <sub>4</sub> | 1/2       | <b>RBP1-212.7</b>             | <b>RBP3-212.7</b> |
|            | 13.5            |                               |           | <b>RBP1-213.5</b>             | <b>RBP3-213.5</b> |
|            | 14.0            |                               |           | <b>RBP1-214</b>               | <b>RBP3-214</b>   |
|            | 15.0            |                               |           | <b>RBP1-215</b>               | <b>RBP3-215</b>   |
|            | 16.0            | G <sup>3</sup> / <sub>8</sub> | 5/8       | <b>RBP1-216</b>               | <b>RBP3-216</b>   |
|            | 17.2            |                               |           | <b>RBP1-217.2</b>             | <b>RBP3-217.2</b> |
|            | 18.0            |                               |           | <b>RBP1-218</b>               | <b>RBP3-218</b>   |
|            | 19.0            |                               |           | <b>RBP1-319</b>               | <b>RBP3-319</b>   |
| 3          | 20.0            | G <sup>1</sup> / <sub>2</sub> | 3/4       | <b>RBP1-320</b>               | <b>RBP3-320</b>   |
|            | 21.3            |                               |           | <b>RBP1-321.3</b>             | <b>RBP3-321.3</b> |
|            | 22.0            |                               |           | <b>RBP1-322</b>               | <b>RBP3-322</b>   |
|            | 25.0            |                               |           | <b>RBP1-325</b>               | <b>RBP3-325</b>   |
|            | 26.9            |                               |           | G <sup>3</sup> / <sub>4</sub> | 1                 |
| 28.0       | <b>RBP1-428</b> | <b>RBP3-428</b>               |           |                               |                   |
| 30.0       | <b>RBP1-430</b> | <b>RBP3-430</b>               |           |                               |                   |
| 5          | 32.0            | G1                            | 1 1/4     | <b>RBP1-532</b>               | <b>RBP3-532</b>   |
|            | 33.7            |                               |           | <b>RBP1-533.7</b>             | <b>RBP3-533.7</b> |
|            | 35.0            |                               |           | <b>RBP1-535</b>               | <b>RBP3-535</b>   |
|            | 38.0            | G1 1/4                        | 1 1/2     | <b>RBP1-538</b>               | <b>RBP3-538</b>   |
|            | 42.0            |                               |           | <b>RBP1-542</b>               | <b>RBP3-542</b>   |

Delivery in unassembled individual components.

\*Only with cover plate, hexagon screws and locking washers.

## Tube clamps

### Tube clamps series B – Complete range

Polypropylene – **RBP**  
 Inside smooth – **RBP**G  
 Polyamide 6 – **RBN**  
 Rubber – **RBVG**\*

(As required please exchange standard abbreviation RBP in column for "Order code")

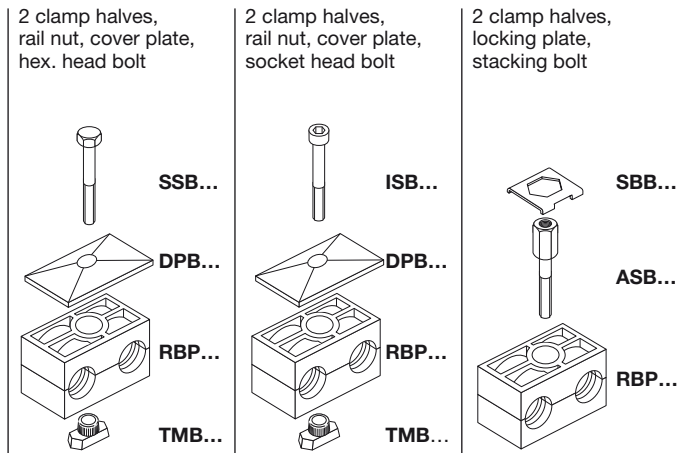

| clamp size | Tube O.D. mm | Tube NB | Tube O.D. | Order code        | Order code        | Order code        |
|------------|--------------|---------|-----------|-------------------|-------------------|-------------------|
| 1          | 6.0          | G 1/8   | 1/4       | <b>RBP4-106</b>   | <b>RBP5-106</b>   | <b>RBP8-106</b>   |
|            | 6.4          |         |           | <b>RBP4-106.4</b> | <b>RBP5-106.4</b> | <b>RBP8-106.4</b> |
|            | 8.0          |         |           | <b>RBP4-108</b>   | <b>RBP5-108</b>   | <b>RBP8-108</b>   |
|            | 9.5          |         |           | <b>RBP4-109.5</b> | <b>RBP5-109.5</b> | <b>RBP8-109.5</b> |
|            | 10.0         |         |           | <b>RBP4-110</b>   | <b>RBP5-110</b>   | <b>RBP8-110</b>   |
|            | 12.0         |         |           | <b>RBP4-112</b>   | <b>RBP5-112</b>   | <b>RBP8-112</b>   |
| 2          | 12.7         | G 1/4   | 1/2       | <b>RBP4-212.7</b> | <b>RBP5-212.7</b> | <b>RBP8-212.7</b> |
|            | 13.5         |         |           | <b>RBP4-213.5</b> | <b>RBP5-213.5</b> | <b>RBP8-213.5</b> |
|            | 14.0         |         |           | <b>RBP4-214</b>   | <b>RBP5-214</b>   | <b>RBP8-214</b>   |
|            | 15.0         |         |           | <b>RBP4-215</b>   | <b>RBP5-215</b>   | <b>RBP8-215</b>   |
|            | 16.0         | G 3/8   | 5/8       | <b>RBP4-216</b>   | <b>RBP5-216</b>   | <b>RBP8-216</b>   |
|            | 17.2         |         |           | <b>RBP4-217.2</b> | <b>RBP5-217.2</b> | <b>RBP8-217.2</b> |
|            | 18.0         |         |           | <b>RBP4-218</b>   | <b>RBP5-218</b>   | <b>RBP8-218</b>   |
|            |              |         |           |                   |                   |                   |
| 3          | 19.0         | G 1/2   | 3/4       | <b>RBP4-319</b>   | <b>RBP5-319</b>   | <b>RBP8-319</b>   |
|            | 20.0         |         |           | <b>RBP4-320</b>   | <b>RBP5-320</b>   | <b>RBP8-320</b>   |
|            | 21.3         |         |           | <b>RBP4-321.3</b> | <b>RBP5-321.3</b> | <b>RBP8-321.3</b> |
|            | 22.0         |         |           | <b>RBP4-322</b>   | <b>RBP5-322</b>   | <b>RBP8-322</b>   |
|            | 25.0         |         |           | <b>RBP4-325</b>   | <b>RBP5-325</b>   | <b>RBP8-325</b>   |
| 4          | 26.9         | G 3/4   | 1         | <b>RBP4-426.9</b> | <b>RBP5-426.9</b> | <b>RBP8-426.9</b> |
|            | 28.0         |         |           | <b>RBP4-428</b>   | <b>RBP5-428</b>   | <b>RBP8-428</b>   |
|            | 30.0         |         |           | <b>RBP4-430</b>   | <b>RBP5-430</b>   | <b>RBP8-430</b>   |
| 5          | 32.0         | G 1     | 1 1/4     | <b>RBP4-532</b>   | <b>RBP5-532</b>   | <b>RBP8-532</b>   |
|            | 33.7         |         |           | <b>RBP4-533.7</b> | <b>RBP5-533.7</b> | <b>RBP8-533.7</b> |
|            | 35.0         |         |           | <b>RBP4-535</b>   | <b>RBP5-535</b>   | <b>RBP8-535</b>   |
|            | 38.0         | G 1 1/4 | 1 1/2     | <b>RBP4-538</b>   | <b>RBP5-538</b>   | <b>RBP8-538</b>   |
|            | 42.0         |         |           | <b>RBP4-542</b>   | <b>RBP5-542</b>   | <b>RBP8-542</b>   |
|            |              |         |           |                   |                   |                   |

Delivery in unassembled individual components.

\*Only with cover plate, hexagon screws and locking washers.

Tube clamps series C (Heavy series) – Components

DIN 3015, part 2

Order code for clamp halves:

- Polypropylene – **RCP**
- Inside smooth – **RCPG<sup>1)</sup>**
- Polyamide 6 – **RCN<sup>1)</sup>**
- Rubber – **RCVR**
- Aluminium – **RCA**

(Please exchange as required standard abbreviation RCP in column for “clamp halves”)

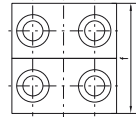
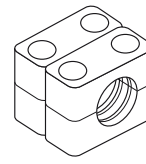
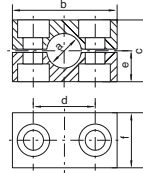
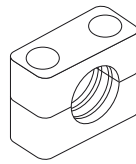

**RCPD**  
(= 2XRCP...)

| clamp size | Tube O.D. mm | Tube NB   | Tube O.D. | 1 part<br>2 clamp halves |             |       |         |     | 1 part<br>4 clamp halves |                       |             |           |         |     |    |           |           |    |    |    |    |    |         |    |    |    |    |    |
|------------|--------------|-----------|-----------|--------------------------|-------------|-------|---------|-----|--------------------------|-----------------------|-------------|-----------|---------|-----|----|-----------|-----------|----|----|----|----|----|---------|----|----|----|----|----|
|            |              |           |           | RCP...<br>Order code     | dimensions: |       |         |     |                          | RCPD...<br>Order code | dimensions: |           |         |     |    |           |           |    |    |    |    |    |         |    |    |    |    |    |
|            |              |           |           | b                        | c           | d     | e       | f   | b                        | c                     | d           | e         | f       |     |    |           |           |    |    |    |    |    |         |    |    |    |    |    |
| 1          | 6.0          | G 1/8     | 5/16      | RCP106X                  | 55          | 32    | 33      | 16  | 30                       | RCPD106               | 55          | 32        | 33      | 16  | 60 |           |           |    |    |    |    |    |         |    |    |    |    |    |
|            | 8.0          |           |           | RCP108X                  |             |       |         |     |                          | RCPD108               |             |           |         |     |    |           |           |    |    |    |    |    |         |    |    |    |    |    |
|            | 10.0         |           |           | RCP110X                  |             |       |         |     |                          | RCPD110               |             |           |         |     |    |           |           |    |    |    |    |    |         |    |    |    |    |    |
|            | 12.0         |           |           | RCP112X                  |             |       |         |     |                          | RCPD112               |             |           |         |     |    |           |           |    |    |    |    |    |         |    |    |    |    |    |
|            | 12.7         |           |           | RCP112.7X                |             |       |         |     |                          | RCPD112.7             |             |           |         |     |    |           |           |    |    |    |    |    |         |    |    |    |    |    |
|            | 13.5         | G 1/4     | 1/2       | RCP113.5X                |             |       |         |     |                          | RCPD113.5             |             |           |         |     |    |           |           |    |    |    |    |    |         |    |    |    |    |    |
|            | 14.0         |           |           | RCP114X                  |             |       |         |     |                          | RCPD114               |             |           |         |     |    |           |           |    |    |    |    |    |         |    |    |    |    |    |
|            | 15.0         |           |           | RCP115X                  |             |       |         |     |                          | RCPD115               |             |           |         |     |    |           |           |    |    |    |    |    |         |    |    |    |    |    |
|            | 16.0         |           |           | RCP116X                  |             |       |         |     |                          | RCPD116               |             |           |         |     |    |           |           |    |    |    |    |    |         |    |    |    |    |    |
|            | 17.2         |           |           | G 3/8                    |             |       |         |     |                          | 5/8                   |             |           |         |     |    | RCP117.2X | RCPD117.2 |    |    |    |    |    |         |    |    |    |    |    |
| 18.0       | RCP118X      | RCPD118   |           |                          |             |       |         |     |                          |                       |             |           |         |     |    |           |           |    |    |    |    |    |         |    |    |    |    |    |
| 2          | 19.0         | G 1/2     | 3/4       |                          | RCP219X     | 70    | 48      | 45  | 24                       |                       | 30          | RCPD219   | 70      | 48  | 45 | 24        | 60        |    |    |    |    |    |         |    |    |    |    |    |
|            | 20.0         |           |           |                          | RCP220X     |       |         |     |                          |                       |             | RCPD220   |         |     |    |           |           |    |    |    |    |    |         |    |    |    |    |    |
|            | 21.3         |           |           |                          | RCP221.3X   |       |         |     |                          |                       |             | RCPD221.3 |         |     |    |           |           |    |    |    |    |    |         |    |    |    |    |    |
|            | 22.0         |           |           | RCP222X                  | RCPD222     |       |         |     |                          |                       |             |           |         |     |    |           |           |    |    |    |    |    |         |    |    |    |    |    |
|            | 23.0         |           |           | RCP223X                  | RCPD223     |       |         |     |                          |                       |             |           |         |     |    |           |           |    |    |    |    |    |         |    |    |    |    |    |
|            | 25.0         | G 3/4     | 1         | RCP225X                  | RCPD225     |       |         |     |                          |                       |             |           |         |     |    |           |           |    |    |    |    |    |         |    |    |    |    |    |
|            | 26.9         |           |           | RCP226.9X                | RCPD226.9   |       |         |     |                          |                       |             |           |         |     |    |           |           |    |    |    |    |    |         |    |    |    |    |    |
|            | 28.0         |           |           | RCP228X                  | RCPD228     |       |         |     |                          |                       |             |           |         |     |    |           |           |    |    |    |    |    |         |    |    |    |    |    |
|            | 30.0         |           |           | RCP230X                  | RCPD230     |       |         |     |                          |                       |             |           |         |     |    |           |           |    |    |    |    |    |         |    |    |    |    |    |
|            | 3            |           |           | 30.0                     | G 1         |       |         |     |                          | 1 1/4                 |             | RCP330X   |         |     |    |           |           | 85 | 60 | 60 | 30 | 30 | RCPD330 | 85 | 60 | 60 | 30 | 60 |
| 32.0       |              | RCP332X   | RCPD332   |                          |             |       |         |     |                          |                       |             |           |         |     |    |           |           |    |    |    |    |    |         |    |    |    |    |    |
| 33.7       |              | RCP333.7X | RCPD333.7 |                          |             |       |         |     |                          |                       |             |           |         |     |    |           |           |    |    |    |    |    |         |    |    |    |    |    |
| 35.0       |              | RCP335X   | RCPD335   |                          |             |       |         |     |                          |                       |             |           |         |     |    |           |           |    |    |    |    |    |         |    |    |    |    |    |
| 38.0       |              | RCP338X   | RCPD338   |                          |             |       |         |     |                          |                       |             |           |         |     |    |           |           |    |    |    |    |    |         |    |    |    |    |    |
| 39.0       |              | G 1 1/4   | 1 1/2     | RCP339X                  | RCPD339     |       |         |     |                          |                       |             |           |         |     |    |           |           |    |    |    |    |    |         |    |    |    |    |    |
| 40.0       |              |           |           | RCP340X                  | RCPD340     |       |         |     |                          |                       |             |           |         |     |    |           |           |    |    |    |    |    |         |    |    |    |    |    |
| 42.0       |              |           |           | RCP342X                  | RCPD342     |       |         |     |                          |                       |             |           |         |     |    |           |           |    |    |    |    |    |         |    |    |    |    |    |
| 4          |              |           |           | 38.0                     | G 1 1/4     | 1 1/2 | RCP438X | 115 | 90                       | 90                    | 45          | 45        | RCPD428 | 115 | 90 | 90        | 45        |    |    |    |    |    | 90      |    |    |    |    |    |
|            |              |           |           | 40.0                     |             |       | RCP440X |     |                          |                       |             |           | RCPD440 |     |    |           |           |    |    |    |    |    |         |    |    |    |    |    |
|            | 42.0         | RCP442X   | RCPD442   |                          |             |       |         |     |                          |                       |             |           |         |     |    |           |           |    |    |    |    |    |         |    |    |    |    |    |
|            | 45.0         | RCP445X   | RCPD445   |                          |             |       |         |     |                          |                       |             |           |         |     |    |           |           |    |    |    |    |    |         |    |    |    |    |    |
|            | 46.0         | RCP446X   | RCPD446   |                          |             |       |         |     |                          |                       |             |           |         |     |    |           |           |    |    |    |    |    |         |    |    |    |    |    |
|            | 48.3         | G 1 1/2   | 2         | RCP448.3X                | RCPD448.3   |       |         |     |                          |                       |             |           |         |     |    |           |           |    |    |    |    |    |         |    |    |    |    |    |
|            | 50.0         |           |           | RCP450X                  | RCPD450     |       |         |     |                          |                       |             |           |         |     |    |           |           |    |    |    |    |    |         |    |    |    |    |    |
|            | 51.0         |           |           | RCP451X                  | RCPD451     |       |         |     |                          |                       |             |           |         |     |    |           |           |    |    |    |    |    |         |    |    |    |    |    |
|            | 52.0         |           |           | RCP452X                  | RCPD452     |       |         |     |                          |                       |             |           |         |     |    |           |           |    |    |    |    |    |         |    |    |    |    |    |
|            | 55.0         |           |           | RCP455X                  | RCPD455     |       |         |     |                          |                       |             |           |         |     |    |           |           |    |    |    |    |    |         |    |    |    |    |    |
|            | 56.0         | G 2       | 2 1/4     | RCP456X                  | RCPD456     |       |         |     |                          |                       |             |           |         |     |    |           |           |    |    |    |    |    |         |    |    |    |    |    |
|            | 57.0         |           |           | RCP457X                  | RCPD457     |       |         |     |                          |                       |             |           |         |     |    |           |           |    |    |    |    |    |         |    |    |    |    |    |
|            | 60.3         |           |           | RCP460.3X                | RCPD460.3   |       |         |     |                          |                       |             |           |         |     |    |           |           |    |    |    |    |    |         |    |    |    |    |    |
|            | 63.0         |           |           | RCP463X                  | RCPD463     |       |         |     |                          |                       |             |           |         |     |    |           |           |    |    |    |    |    |         |    |    |    |    |    |
|            | 65.0         |           |           | RCP465X                  | RCPD465     |       |         |     |                          |                       |             |           |         |     |    |           |           |    |    |    |    |    |         |    |    |    |    |    |
| 66.0       | 2 1/2        | 2 1/2     | RCP466X   | RCPD466                  |             |       |         |     |                          |                       |             |           |         |     |    |           |           |    |    |    |    |    |         |    |    |    |    |    |
| 70.0       |              |           | RCP470X   | RCPD470                  |             |       |         |     |                          |                       |             |           |         |     |    |           |           |    |    |    |    |    |         |    |    |    |    |    |

Continuation see next page ...

## Tube clamps

### Tube clamps series C (Heavy series) – Components (Continued)

#### Order code for clamp halves:

Polypropylene – **RCP**  
 Inside smooth – **RCPG**<sup>1)</sup>  
 Polyamide 6 – **RCN**<sup>1)</sup>  
 Rubber – **RCVR**  
 Aluminium – **RCA**

(Please exchange as required standard abbreviation  
 RCP in column for “clamp halves”)

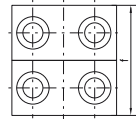
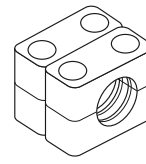
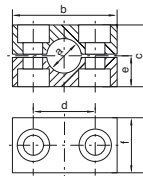
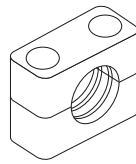

**RCPD**  
 (= 2XRCP...)

| clamp size | Tube O.D. mm | Tube NB    | Tube O.D.                     | 1 part<br>2 clamp halves |                          |     |     |     |     | 1 part<br>4 clamp halves |                          |     |     |     |     |
|------------|--------------|------------|-------------------------------|--------------------------|--------------------------|-----|-----|-----|-----|--------------------------|--------------------------|-----|-----|-----|-----|
|            |              |            |                               | RCP...<br>Order code     | dimensions:<br>b c d e f |     |     |     |     | RCPD...<br>Order code    | dimensions:<br>b c d e f |     |     |     |     |
| 5          | 70.0         | G 2½       | 3                             | RCP570X                  | 152                      | 120 | 122 | 60  | 60  | RCPD570                  | 152                      | 120 | 122 | 60  | 120 |
|            | 73.0         |            |                               | RCP573X                  |                          |     |     |     |     | RCPD573                  |                          |     |     |     |     |
|            | 75.0         |            |                               | RCP575X                  |                          |     |     |     |     | RCPD575                  |                          |     |     |     |     |
|            | 76.1         |            |                               | RCP576.1X                |                          |     |     |     |     | RCPD576.1                |                          |     |     |     |     |
|            | 80.0         | RCP580X    | RCPD580                       |                          |                          |     |     |     |     |                          |                          |     |     |     |     |
|            | 82.5         | RCP582.5X  | RCPD582.5                     |                          |                          |     |     |     |     |                          |                          |     |     |     |     |
|            | 88.9         | RCP588.9X  | RCPD588.9                     |                          |                          |     |     |     |     |                          |                          |     |     |     |     |
| 90.0       | RCP590X      | RCPD590    |                               |                          |                          |     |     |     |     |                          |                          |     |     |     |     |
| 6          | 90.0         | G 3½       | 4                             | RCP690X                  | 205                      | 170 | 168 | 85  | 80  | RCPD690                  | 205                      | 170 | 168 | 85  | 160 |
|            | 97.0         |            |                               | RCP697X                  |                          |     |     |     |     | RCPD697                  |                          |     |     |     |     |
|            | 100.0        |            |                               | RCP6100X                 |                          |     |     |     |     | RCPD6100                 |                          |     |     |     |     |
|            | 101.6        |            |                               | RCP6101.6X               |                          |     |     |     |     | RCPD6101.6               |                          |     |     |     |     |
|            | 108.0        | RCP6108X   | RCPD6108                      |                          |                          |     |     |     |     |                          |                          |     |     |     |     |
|            | 114.3        | RCP6114.3X | RCPD6114.3                    |                          |                          |     |     |     |     |                          |                          |     |     |     |     |
|            | 127.0        | RCP6127X   | RCPD6127                      |                          |                          |     |     |     |     |                          |                          |     |     |     |     |
| 7          | 127.0        | G 5        | 5                             | RCP7127X                 | 250                      | 200 | 205 | 100 | 90  | RCPD7127                 | 250                      | 200 | 205 | 100 | 180 |
|            | 133.0        |            |                               | RCP7133X                 |                          |     |     |     |     | RCPD7133                 |                          |     |     |     |     |
|            | 140.0        |            |                               | RCP7140X                 |                          |     |     |     |     | RCPD7140                 |                          |     |     |     |     |
|            | 150.0        |            |                               | RCP7150X                 |                          |     |     |     |     | RCPD7150                 |                          |     |     |     |     |
|            | 152.4        | RCP7152.4X | RCPD7152.4                    |                          |                          |     |     |     |     |                          |                          |     |     |     |     |
|            | 159.0        | RCP7159X   | RCPD7159                      |                          |                          |     |     |     |     |                          |                          |     |     |     |     |
|            | 165.1        | RCP7165.1X | RCPD7165.1                    |                          |                          |     |     |     |     |                          |                          |     |     |     |     |
| 168.3      | RCP7168.3X   | RCPD7168.3 |                               |                          |                          |     |     |     |     |                          |                          |     |     |     |     |
| 8          | 168.3        | G 8        | 6 <sup>5</sup> / <sub>8</sub> | RCP8168.3X               | 320                      | 270 | 265 | 135 | 120 | RCPD8168.3               | 320                      | 270 | 265 | 135 | 240 |
|            | 177.8        |            | 7                             | RCP8177.8X               |                          |     |     |     |     | RCPD8177.8               |                          |     |     |     |     |
|            | 193.7        |            | 7 <sup>5</sup> / <sub>8</sub> | RCP8193.7X               |                          |     |     |     |     | RCPD8193.7               |                          |     |     |     |     |
|            | 203.0        |            | 8                             | RCP8203X                 |                          |     |     |     |     | RCPD8203                 |                          |     |     |     |     |
|            | 219.1        |            | 8 <sup>5</sup> / <sub>8</sub> | RCP8219.1X               |                          |     |     |     |     | RCPD8219.1               |                          |     |     |     |     |
|            | 220.0        |            |                               | RCP8220X                 |                          |     |     |     |     | RCPD8220                 |                          |     |     |     |     |
|            | 9            |            | 219.1                         | G8                       |                          |     |     |     |     |                          |                          |     |     |     |     |
| 244.5      |              | RCP9244.5X |                               |                          |                          |     |     |     |     |                          |                          |     |     |     |     |
| 250.0      |              | RCP9250X   |                               |                          |                          |     |     |     |     |                          |                          |     |     |     |     |
| 273.0      |              | RCP9273X   |                               |                          |                          |     |     |     |     |                          |                          |     |     |     |     |
| 323.9      |              | RCP9323.9X |                               |                          |                          |     |     |     |     |                          |                          |     |     |     |     |
| 10         | 355.6        | G10        |                               | RCP10355.6X              | 630                      | 530 | 530 | 265 | 180 |                          |                          |     |     |     |     |
|            | 406.4        | G12        |                               | RCP10406.4X              |                          |     |     |     |     |                          |                          |     |     |     |     |

Metal parts also available in stainless steel.

<sup>1)</sup> Only sizes 1–4

Tube clamps series C (Heavy series) – Components

DIN 3015, part 2

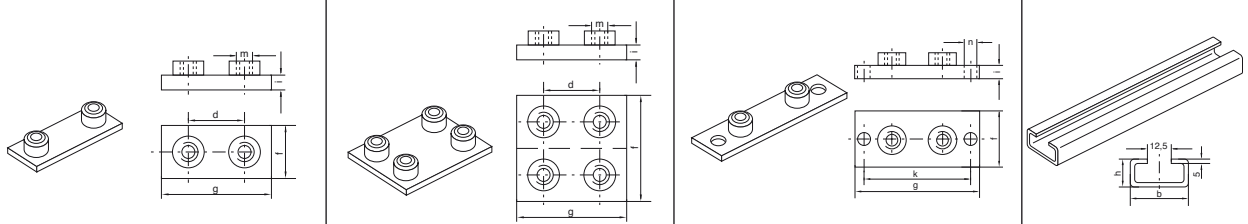

| clamp size | AP C...<br>Order code | weld plate dimensions: |     |     |    |     | APDC C...<br>Order code | double weld plate dimensions: |     |     |    |     | APLC C...<br>Order code | weld/screw plate dimensions: |     |    |     |    | TSC C...<br>Order code                       | mounting rail dim.: |    |
|------------|-----------------------|------------------------|-----|-----|----|-----|-------------------------|-------------------------------|-----|-----|----|-----|-------------------------|------------------------------|-----|----|-----|----|--|---------------------|----|
|            |                       | d                      | f   | g   | i  | m   |                         | d                             | f   | g   | i  | m   |                         | g                            | f   | i  | k   | n  |  | b                   | h  |
| 1          | APC1X                 | 33                     | 30  | 73  | 8  | M10 | APDC1X                  | 33                            | 60  | 73  | 8  | M10 | APLC1X                  | 113                          | 30  | 8  | 85  | 11 | TSC1X<br>(1 Meter)<br><br>TSC2X<br>(2 Meter) | 40                  | 22 |
| 2          | APC2X                 | 45                     | 30  | 85  | 8  | M10 | APDC2X                  | 45                            | 60  | 85  | 8  | M10 | APLC2X                  | 125                          | 30  | 8  | 97  | 11 |  |                     |    |
| 3          | APC3X                 | 60                     | 30  | 100 | 8  | M10 | APDC3X                  | 60                            | 60  | 100 | 8  | M10 | APLC3X                  | 140                          | 30  | 8  | 112 | 11 |  |                     |    |
| 4          | APC4X                 | 90                     | 45  | 140 | 10 | M12 | APDC4X                  | 90                            | 90  | 140 | 10 | M12 | APLC4X                  | 190                          | 45  | 10 | 160 | 14 |  |                     |    |
| 5          | APC5X                 | 122                    | 60  | 180 | 10 | M16 | APDC5X                  | 122                           | 120 | 180 | 10 | M16 | APLC5X                  | 240                          | 60  | 10 | 205 | 18 |  |                     |    |
| 6          | APC6X                 | 168                    | 80  | 225 | 15 | M20 | APDC6X                  | 168                           | 160 | 225 | 15 | M20 | APLC6X                  | 310                          | 80  | 15 | 270 | 22 |  |                     |    |
| 7          | APC7X                 | 205                    | 90  | 270 | 15 | M24 | APDC7X                  | 205                           | 180 | 270 | 15 | M24 | APLC7X                  | 370                          | 90  | 15 | 320 | 26 |  |                     |    |
| 8          | APC8X                 | 265                    | 120 | 340 | 25 | M30 | APDC8X                  | 265                           | 240 | 340 | 25 | M30 | APLC8X                  | 450                          | 120 | 25 | 390 | 33 |  |                     |    |
| 9          | APC9X                 | 395                    | 160 | 520 | 30 | M30 | APDC9X                  | 395                           | 324 | 520 | 30 | M30 |                         |                              |     |    |     |    |  |                     |    |
| 10         | APC10X                | 530                    | 180 | 680 | 30 | M30 | APDC10X                 | 530                           | 364 | 680 | 30 | M30 |                         |                              |     |    |     |    |  |                     |    |

Metal parts also available in stainless steel.  
 Complete programme range please refer to page 240.

## Tube clamps

### Tube clamps series C (Heavy series) – Components

DIN 3015, part 2

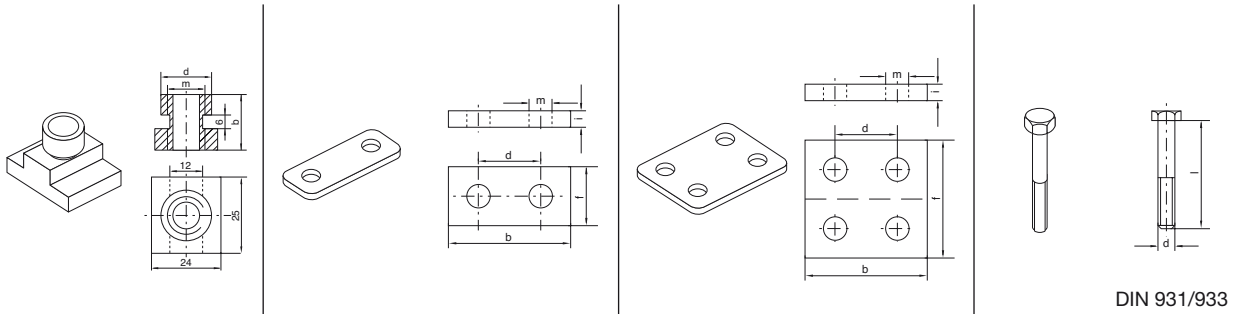

| clamp size | rail nut              |             |      | cover plate |                       |             |     |     | double cover plate |    |                        |             |     | hexagon head |    |    |                       |                      |
|------------|-----------------------|-------------|------|-------------|-----------------------|-------------|-----|-----|--------------------|----|------------------------|-------------|-----|--------------|----|----|-----------------------|----------------------|
|            | TM C...<br>Order code | dimensions: |      |             | DP C...<br>Order code | dimensions: |     |     |                    |    | DPD C...<br>Order code | dimensions: |     |              |    |    | SS C...<br>Order code | dimensions:<br>d × L |
|            |                       | b           | d    | m           |                       | b           | d   | f   | i                  | m  |                        | b           | d   | f            | i  | m  |                       |                      |
| 1          | <b>TMC1X</b>          | 20          | 17.8 | M 10        | <b>DPC1X</b>          | 55          | 33  | 30  | 8                  | 11 | <b>DPDC1X</b>          | 55          | 33  | 60           | 8  | 11 | <b>SSC1X</b>          | M 10 × 45            |
| 2          |                       |             |      |             | <b>DPC2X</b>          | 70          | 45  | 30  | 8                  | 11 | <b>DPDC2X</b>          | 70          | 45  | 60           | 8  | 11 | <b>SSC2X</b>          | M 10 × 60            |
| 3          |                       |             |      |             | <b>DPC3X</b>          | 85          | 60  | 30  | 8                  | 11 | <b>DPDC3X</b>          | 85          | 60  | 60           | 8  | 11 | <b>SSC3X</b>          | M 10 × 70            |
| 4          | <b>TMC4X</b>          | 23          | 19.8 | M 12        | <b>DPC4X</b>          | 115         | 90  | 45  | 10                 | 14 | <b>DPDC4X</b>          | 115         | 90  | 90           | 10 | 14 | <b>SSC4X</b>          | M 12 × 100           |
| 5          |                       |             |      |             | <b>DPC5X</b>          | 152         | 122 | 60  | 10                 | 18 | <b>DPDC5X</b>          | 152         | 122 | 120          | 10 | 18 | <b>SSC5X</b>          | M 16 × 130           |
| 6          |                       |             |      |             | <b>DPC6X</b>          | 205         | 168 | 80  | 15                 | 22 | <b>DPDC6X</b>          | 205         | 168 | 160          | 15 | 22 | <b>SSC6X</b>          | M 20 × 190           |
| 7          |                       |             |      |             | <b>DPC7X</b>          | 250         | 205 | 90  | 15                 | 26 | <b>DPDC7X</b>          | 250         | 205 | 180          | 15 | 26 | <b>SSC7X</b>          | M 24 × 220           |
| 8          |                       |             |      |             | <b>DPC8X</b>          | 320         | 265 | 120 | 25                 | 33 | <b>DPDC8X</b>          | 320         | 265 | 240          | 25 | 33 | <b>SSC8X</b>          | M 30 × 300           |
| 9          |                       |             |      |             | <b>DPC9X</b>          | 466         | 395 | 160 | 30                 | 35 | <b>DPDC9X</b>          | 466         | 395 | 324          | 30 | 35 | <b>SSC9X</b>          | M 30 × 450           |
| 10         |                       |             |      |             | <b>DPC10X</b>         | 630         | 530 | 180 | 30                 | 35 | <b>DPDC10X</b>         | 630         | 530 | 364          | 30 | 35 | <b>SSC10X</b>         | M 30 × 560           |

Metal parts also available in stainless steel.

**Tube clamps series C (Heavy series) – Components**

DIN 3015, part 2

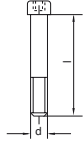

DIN 912

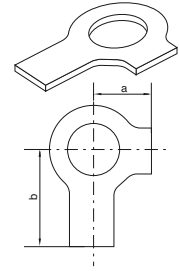
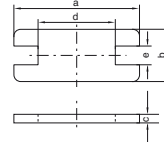
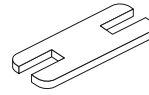
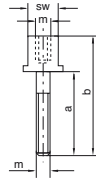
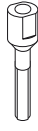

| clamp size | socket head           |                      | stacking              |                         |     |      | locking plate <sup>1)</sup> |                       |                          |     |    | locking washer <sup>2)</sup> |      |                       |                    |    |
|------------|-----------------------|----------------------|-----------------------|-------------------------|-----|------|-----------------------------|-----------------------|--------------------------|-----|----|------------------------------|------|-----------------------|--------------------|----|
|            | IS C...<br>Order code | dimensions:<br>d × L | AS C...<br>Order code | dimensions:<br>a b m SW |     |      |                             | SP C...<br>Order code | dimensions:<br>a b c d e |     |    |                              |      | US C...<br>Order code | dimensions:<br>a b |    |
| 1          | <b>ISC1X</b>          | M 10 × 45            | <b>ASC1X</b>          | 25                      | 51  | M 10 | 15                          | <b>SPC1X</b>          | 55                       | 30  | 8  | 14                           | 15.5 | <b>USC1X</b>          | 13                 | 22 |
| 2          | <b>ISC2X</b>          | M 10 × 60            | <b>ASC2X</b>          | 40                      | 66  | M 10 | 15                          | <b>SPC2X</b>          | 70                       | 30  | 8  | 26                           | 15.5 |                       |                    |    |
| 3          | <b>ISC3X</b>          | M 10 × 70            | <b>ASC3X</b>          | 50                      | 76  | M 10 | 15                          | <b>SPC3X</b>          | 85                       | 30  | 8  | 41                           | 15.5 |                       |                    |    |
| 4          | <b>ISC4X</b>          | M 12 × 100           | <b>ASC4X</b>          | 85                      | 112 | M 12 | 17                          | <b>SPC4X</b>          | 115                      | 45  | 10 | 69                           | 17.5 | <b>USC4X</b>          | 15                 | 28 |
| 5          | <b>ISC5X</b>          | M 16 × 130           | <b>ASC5X</b>          | 110                     | 146 | M 16 | 21                          | <b>SPC5X</b>          | 152                      | 60  | 10 | 97                           | 21.5 | <b>USC5X</b>          | 18                 | 32 |
| 6          | <b>ISC6X</b>          | M 20 × 190           | <b>ASC6X</b>          | 155                     | 206 | M 20 | 27                          | <b>SPC6X</b>          | 205                      | 80  | 15 | 137                          | 27.5 | <b>USC6X</b>          | 21                 | 36 |
| 7          | <b>ISC7X</b>          | M 24 × 220           | <b>ASC7X</b>          | 185                     | 245 | M 24 | 30                          | <b>SPC7X</b>          | 250                      | 90  | 15 | 169                          | 30.5 | <b>USC7X</b>          | 25                 | 42 |
| 8          | <b>ISC8X</b>          | M 30 × 300           | <b>ASC8X</b>          | 250                     | 330 | M 30 | 36                          | <b>SPC8X</b>          | 320                      | 120 | 25 | 219                          | 36.5 | <b>USC8X</b>          | 32                 | 52 |

<sup>1)</sup> The use of stacking screws necessitates the use of locking plates in the construction assembly!

<sup>2)</sup> When assembling solid rubber clamps, covering plates, hexagon screws and locking washers must be used. Metal parts also available in stainless steel.

## Tube clamps

### Tube clamps series C – Complete range

Polypropylene – **RCP**  
 Inside smooth – **RCPG<sup>1</sup>**  
 Polyamide 6 – **RCN**  
 Rubber – **RCVR\***  
 Aluminium – **RCA**

(As required please exchange standard abbreviation  
 RCP in column for "Order code")

2 clamp halves, weld plate,  
 cover plate, hex. head bolt

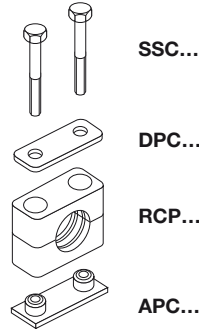

2 clamp halves, weld plate,  
 cover plate, socket head bolt

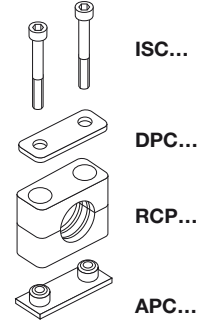

| clamp size | Tube O.D. mm    | Tube NB           | Tube O.D.         | Order code        | Order code        |
|------------|-----------------|-------------------|-------------------|-------------------|-------------------|
| 1          | 6.0             | G 1/8             | 5/16              | <b>RCP1-106</b>   | <b>RCP2-106</b>   |
|            | 8.0             |                   |                   | <b>RCP1-108</b>   | <b>RCP2-108</b>   |
|            | 10.0            |                   |                   | <b>RCP1-110</b>   | <b>RCP2-110</b>   |
|            | 12.0            | G 1/4             | 1/2               | <b>RCP1-112</b>   | <b>RCP2-112</b>   |
|            | 12.7            |                   |                   | <b>RCP1-112.7</b> | <b>RCP2-112.7</b> |
|            | 13.5            |                   |                   | <b>RCP1-113.5</b> | <b>RCP2-113.5</b> |
|            | 14.0            |                   |                   | <b>RCP1-114</b>   | <b>RCP2-114</b>   |
|            | 15.0            | G 3/8             | 5/8               | <b>RCP1-115</b>   | <b>RCP2-115</b>   |
|            | 16.0            |                   |                   | <b>RCP1-116</b>   | <b>RCP2-116</b>   |
|            | 17.2            |                   |                   | <b>RCP1-117.2</b> | <b>RCP2-117.2</b> |
| 18.0       | <b>RCP1-118</b> |                   |                   | <b>RCP2-118</b>   |                   |
| 2          | 19.0            |                   |                   | G 1/2             | 3/4               |
|            | 20.0            | <b>RCP1-220</b>   | <b>RCP2-220</b>   |                   |                   |
|            | 21.3            | <b>RCP1-221.3</b> | <b>RCP2-221.3</b> |                   |                   |
|            | 22.0            | <b>RCP1-222</b>   | <b>RCP2-222</b>   |                   |                   |
|            | 23.0            | G 3/4             | 1                 | <b>RCP1-223</b>   | <b>RCP2-223</b>   |
|            | 25.0            |                   |                   | <b>RCP1-225</b>   | <b>RCP2-225</b>   |
|            | 26.9            |                   |                   | <b>RCP1-226.9</b> | <b>RCP2-226.9</b> |
|            | 28.0            |                   |                   | <b>RCP1-228</b>   | <b>RCP2-228</b>   |
| 30.0       | <b>RCP1-230</b> | <b>RCP2-230</b>   |                   |                   |                   |
| 3          | 30.0            | G 1               | 1 1/4             | <b>RCP1-330</b>   | <b>RCP2-330</b>   |
|            | 32.0            |                   |                   | <b>RCP1-332</b>   | <b>RCP2-332</b>   |
|            | 33.7            |                   |                   | <b>RCP1-333.7</b> | <b>RCP2-333.7</b> |
|            | 35.0            |                   |                   | <b>RCP1-335</b>   | <b>RCP2-335</b>   |
|            | 38.0            | G 1 1/4           | 1 1/2             | <b>RCP1-338</b>   | <b>RCP2-338</b>   |
|            | 40.0            |                   |                   | <b>RCP1-340</b>   | <b>RCP2-340</b>   |
|            | 42.0            |                   |                   | <b>RCP1-342</b>   | <b>RCP2-342</b>   |
| 4          | 38.0            | G 1 1/4           | 1 1/2             | <b>RCP1-438</b>   | <b>RCP2-438</b>   |
|            | 40.0            |                   |                   | <b>RCP1-440</b>   | <b>RCP2-440</b>   |
|            | 42.0            |                   |                   | <b>RCP1-442</b>   | <b>RCP2-442</b>   |
|            | 45.0            |                   |                   | <b>RCP1-445</b>   | <b>RCP2-445</b>   |
|            | 48.3            | G 1 1/2           | 2                 | <b>RCP1-448.3</b> | <b>RCP2-448.3</b> |
|            | 50.0            |                   |                   | <b>RCP1-450</b>   | <b>RCP2-450</b>   |
|            | 51.0            |                   |                   | <b>RCP1-451</b>   | <b>RCP2-451</b>   |
|            | 52.0            | G 2               | 2 1/4             | <b>RCP1-452</b>   | <b>RCP2-452</b>   |
|            | 55.0            |                   |                   | <b>RCP1-455</b>   | <b>RCP2-455</b>   |
|            | 57.0            |                   |                   | <b>RCP1-457</b>   | <b>RCP2-457</b>   |
|            | 60.3            |                   |                   | <b>RCP1-460.3</b> | <b>RCP2-460.3</b> |
|            | 63.0            |                   |                   | <b>RCP1-463</b>   | <b>RCP2-463</b>   |
|            | 65.0            |                   |                   | <b>RCP1-465</b>   | <b>RCP2-465</b>   |
|            | 70.0            |                   |                   | <b>RCP1-470</b>   | <b>RCP2-470</b>   |

Continuation see next page ...



Tube clamps series C – Complete range (Continued)

Polypropylene – **RCP**  
 Inside smooth – **RCPG<sup>1)</sup>**  
 Polyamide 6 – **RCN**  
 Rubber – **RCVR\***  
 Aluminium – **RCA**

(As required please exchange standard abbreviation  
 RCP in column for “Order code”)

2 clamp halves, weld plate,  
 cover plate, hex. head bolt

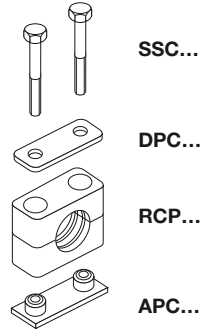

2 clamp halves, weld plate,  
 cover plate, socket head bolt

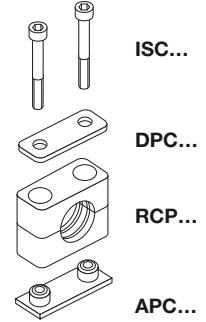

| clamp size | Tube O.D. mm       | Tube NB | Tube O.D.        | Order code         | Order code         |
|------------|--------------------|---------|------------------|--------------------|--------------------|
| 5          | 70.0               | G 2½    | 3                | <b>RCP1-570</b>    | <b>RCP2-570</b>    |
|            | 73.0               |         |                  | <b>RCP1-573</b>    | <b>RCP2-573</b>    |
|            | 75.0               |         |                  | <b>RCP1-575</b>    | <b>RCP2-575</b>    |
|            | 76.1               |         |                  | <b>RCP1-576.1</b>  | <b>RCP2-576.1</b>  |
|            | 80.0               | G 3     | 3¼               | <b>RCP1-580</b>    | <b>RCP2-580</b>    |
|            | 82.5               |         |                  | <b>RCP1-582.5</b>  | <b>RCP2-582.5</b>  |
|            | 88.9               |         |                  | <b>RCP1-588.9</b>  | <b>RCP2-588.9</b>  |
| 90.0       |                    |         | <b>RCP1-590</b>  | <b>RCP2-590</b>    |                    |
| 6          | 90.0               | G 3½    | 4                | <b>RCP1-690</b>    | <b>RCP2-690</b>    |
|            | 97.0               |         |                  | <b>RCP1-697</b>    | <b>RCP2-697</b>    |
|            | 100.0              |         |                  | <b>RCP1-6100</b>   | <b>RCP2-6100</b>   |
|            | 101.6              | G 4     | 4¼               | <b>RCP1-6101.6</b> | <b>RCP2-6101.6</b> |
|            | 108.0              |         |                  | <b>RCP1-6108</b>   | <b>RCP2-6108</b>   |
|            | 114.3              |         |                  | <b>RCP1-6114.3</b> | <b>RCP2-6114.3</b> |
| 127.0      |                    | 5       | <b>RCP1-6127</b> | <b>RCP2-6127</b>   |                    |
| 7          | 127.0              | G 5     | 5                | <b>RCP1-7127</b>   | <b>RCP2-7127</b>   |
|            | 133.0              |         |                  | <b>RCP1-7133</b>   | <b>RCP2-7133</b>   |
|            | 140.0              |         |                  | <b>RCP1-7140</b>   | <b>RCP2-7140</b>   |
|            | 150.0              | G 5½    | 5½               | <b>RCP1-7150</b>   | <b>RCP2-7150</b>   |
|            | 152.4              |         |                  | <b>RCP1-7152.4</b> | <b>RCP2-7152.4</b> |
|            | 159.0              |         |                  | <b>RCP1-7159</b>   | <b>RCP2-7159</b>   |
|            | 165.1              | G 6     | 6¼               | <b>RCP1-7165.1</b> | <b>RCP2-7165.1</b> |
| 168.3      | <b>RCP1-7168.3</b> |         |                  | <b>RCP2-7168.3</b> |                    |
| 8          | 168.3              | G 8     | 6⅝               | <b>RCP1-8168.3</b> | <b>RCP2-8168.3</b> |
|            | 177.8              |         | 7                | <b>RCP1-8177.8</b> | <b>RCP2-8177.8</b> |
|            | 193.7              |         | 7⅝               | <b>RCP1-8193.7</b> | <b>RCP2-8193.7</b> |
|            | 203.0              |         |                  | <b>RCP1-8203</b>   | <b>RCP2-8203</b>   |
|            | 219.1              |         | 8⅝               | <b>RCP1-8219.1</b> | <b>RCP2-8219.1</b> |
|            | 220.0              |         |                  | <b>RCP1-8220</b>   | <b>RCP2-8220</b>   |

Delivery in unassembled individual components.

<sup>1)</sup> Only sizes 1–4

\* Only with cover plate, hexagon screws and locking washers (only sizes 1–4).

## Tube clamps

### Tube clamps series C – Complete range

Polypropylene – **RCP**  
 Inside smooth – **RCPG<sup>1)</sup>**  
 Polyamide 6 – **RCN**  
 Rubber – **RCVR\***  
 Aluminium – **RCA**

(As required please exchange standard abbreviation  
 RCP in column for "Order code")

2 clamp halves,  
 rail nuts, cover plate,  
 hex. head bolts

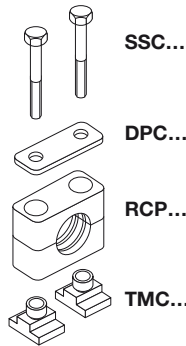

2 clamp halves,  
 rail nuts, cover plate,  
 socket head bolts

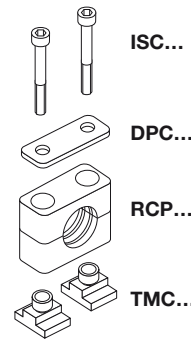

2 clamp halves,  
 locking plate, stacking  
 bolts

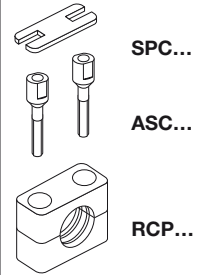

| clamp size | Tube O.D. mm | Tube NB    | Tube O.D.  | Order code | Order code | Order code |
|------------|--------------|------------|------------|------------|------------|------------|
| 1          | 6.0          | G 1/8      | 5/16       | RCP3-106   | RCP4-106   | RCP5-106   |
|            | 8.0          |            |            | RCP3-108   | RCP4-108   | RCP5-108   |
|            | 10.0         |            |            | RCP3-110   | RCP4-110   | RCP5-110   |
|            | 12.0         | G 1/4      | 1/2        | RCP3-112   | RCP4-112   | RCP5-112   |
|            | 12.7         |            |            | RCP3-112.7 | RCP4-112.7 | RCP5-112.7 |
|            | 13.5         |            |            | RCP3-113.5 | RCP4-113.5 | RCP5-113.5 |
|            | 14.0         |            |            | RCP3-114   | RCP4-114   | RCP5-114   |
|            | 15.0         | G 3/8      | 5/8        | RCP3-115   | RCP4-115   | RCP5-115   |
|            | 16.0         |            |            | RCP3-116   | RCP4-116   | RCP5-116   |
|            | 17.2         |            |            | RCP3-117.2 | RCP4-117.2 | RCP5-117.2 |
| 18.0       | RCP3-118     |            |            | RCP4-118   | RCP5-118   |            |
| 2          | 19.0         | G 1/2      | 3/4        | RCP3-219   | RCP4-219   | RCP5-219   |
|            | 20.0         |            |            | RCP3-220   | RCP4-220   | RCP5-220   |
|            | 21.3         |            |            | RCP3-221.3 | RCP4-221.3 | RCP5-221.3 |
|            | 22.0         |            |            | RCP3-222   | RCP4-222   | RCP5-222   |
|            | 23.0         | G 3/4      | 1          | RCP3-223   | RCP4-223   | RCP5-223   |
|            | 25.0         |            |            | RCP3-225   | RCP4-225   | RCP5-225   |
|            | 26.9         |            |            | RCP3-226.9 | RCP4-226.9 | RCP5-226.9 |
|            | 28.0         |            |            | RCP3-228   | RCP4-228   | RCP5-228   |
|            | 30.0         |            |            | RCP3-230   | RCP4-230   | RCP5-230   |
|            | 3            |            |            | 30.0       | G 1        | 1 1/4      |
| 32.0       |              | RCP3-332   | RCP4-332   | RCP5-332   |            |            |
| 33.7       |              | RCP3-333.7 | RCP4-333.7 | RCP5-333.7 |            |            |
| 35.0       |              | RCP3-335   | RCP4-335   | RCP5-335   |            |            |
| 38.0       |              | G 1 1/4    | 1 1/2      | RCP3-338   | RCP4-338   | RCP5-338   |
| 40.0       |              |            |            | RCP3-340   | RCP4-340   | RCP5-340   |
| 42.0       |              |            |            | RCP3-342   | RCP4-342   | RCP5-342   |
| 4          |              |            |            | 38.0       | G 1 1/4    | 1 1/2      |
|            | 40.0         | RCP3-440   | RCP4-440   | RCP5-440   |            |            |
|            | 42.0         | RCP3-442   | RCP4-442   | RCP5-442   |            |            |
|            | 45.0         | RCP3-445   | RCP4-445   | RCP5-445   |            |            |
|            | 48.3         | G 1 1/2    | 2          | RCP3-448.3 | RCP4-448.3 | RCP5-448.3 |
|            | 50.0         |            |            | RCP3-450   | RCP4-450   | RCP5-450   |
|            | 51.0         |            |            | RCP3-451   | RCP4-451   | RCP5-451   |
|            | 52.0         |            |            | RCP3-452   | RCP4-452   | RCP5-452   |
|            | 55.0         | G 2        | 2 1/4      | RCP3-455   | RCP4-455   | RCP5-455   |
|            | 57.0         |            |            | RCP3-457   | RCP4-457   | RCP5-457   |
|            | 60.3         |            |            | RCP3-460.3 | RCP4-460.3 | RCP5-460.3 |
|            | 63.0         |            |            | RCP3-463   | RCP4-463   | RCP5-463   |
| 65.0       | 2 1/2        | 2 1/2      | RCP3-465   | RCP4-465   | RCP5-465   |            |
| 70.0       |              |            | RCP3-470   | RCP4-470   | RCP5-470   |            |

Continuation see next page ...



Tube clamps series C – Complete range (Continued)

Polypropylene – **RCP**  
 Inside smooth – **RCPG<sup>1)</sup>**  
 Polyamide 6 – **RCN**  
 Rubber – **RCVR\***  
 Aluminium – **RCA**

(As required please exchange standard abbreviation RCP in column for “Order code”)

2 clamp halves, locking plate, stacking bolts

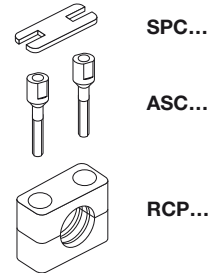

| clamp size | Tube O.D. mm       | Tube NB | Tube O.D.        | Order code         |                    |
|------------|--------------------|---------|------------------|--------------------|--------------------|
| 5          | 70.0               | G 2½    | 3                | <b>RCP5-570</b>    |                    |
|            | 73.0               |         |                  | <b>RCP5-573</b>    |                    |
|            | 75.0               |         |                  | <b>RCP5-575</b>    |                    |
|            | 76.1               |         |                  | <b>RCP5-576.1</b>  |                    |
|            | 80.0               | G 3     | 3¼               | <b>RCP5-580</b>    |                    |
|            | 82.5               |         |                  | <b>RCP5-582.5</b>  |                    |
|            | 88.9               |         |                  | <b>RCP5-588.9</b>  |                    |
| 90.0       |                    |         | <b>RCP5-590</b>  |                    |                    |
| 6          | 90.0               | G 3½    | 4                | <b>RCP5-690</b>    |                    |
|            | 97.0               |         |                  | <b>RCP5-697</b>    |                    |
|            | 100.0              |         |                  | <b>RCP5-6100</b>   |                    |
|            | 101.6              | G 4     | 4¼               | <b>RCP5-6101.6</b> |                    |
|            | 108.0              |         |                  | <b>RCP5-6108</b>   |                    |
|            | 114.3              |         |                  | <b>RCP5-6114.3</b> |                    |
| 127.0      |                    | 5       | <b>RCP5-6127</b> |                    |                    |
| 7          | 127.0              | G 5     | 5                | <b>RCP5-7127</b>   |                    |
|            | 133.0              |         |                  | <b>RCP5-7133</b>   |                    |
|            | 140.0              |         |                  | <b>RCP5-7140</b>   |                    |
|            | 150.0              | G 5½    | 6                | <b>RCP5-7150</b>   |                    |
|            | 152.4              |         |                  | <b>RCP5-7152.4</b> |                    |
|            | 159.0              |         |                  | <b>RCP5-7159</b>   |                    |
|            | 165.1              | G 6     | 6½               | <b>RCP5-7165.1</b> |                    |
| 168.3      | <b>RCP5-7168.3</b> |         |                  |                    |                    |
| 8          | 168.3              | G 8     | 6⅝               | <b>RCP5-8168.3</b> |                    |
|            | 177.8              |         | 7                | <b>RCP5-8177.8</b> |                    |
|            | 193.7              |         | 7⅝               | <b>RCP5-8193.7</b> |                    |
|            | 203.0              |         | 8⅝               |                    | <b>RCP5-8203</b>   |
|            | 219.1              |         |                  |                    | <b>RCP5-8219.1</b> |
|            | 220.0              |         |                  |                    | <b>RCP5-8220</b>   |

Delivery in unassembled individual components.

<sup>1)</sup> Only sizes 1–4

\* Only with cover plate, hexagon screws and locking washers (only sizes 1–4).

## Tube clamps

### Tube clamps series C – Complete range

Polypropylene – **RCPD**  
 Inside smooth – **RCPDG<sup>1</sup>**  
 Polyamide 6 – **RCND**  
 Rubber – **RCVDR\***  
 Aluminium – **RCAD**

(As required please exchange standard abbreviation  
 RCP in column for "Order code")

4 clamp halves, double weld plate,  
 double cover plate, hex. head bolts

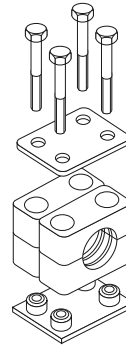

SSC...

DPDC...

RCPD...  
 (=2XRCP...)

APDC...

4 clamp halves, double weld  
 plate, double cover plate, socket  
 head bolts

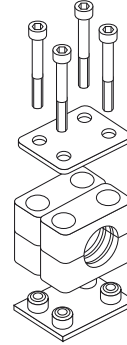

ISC...

DPDC...

RCPD...  
 (=2XRCP...)

APDC...

| clamp size | Tube O.D. mm | Tube NB     | Tube O.D. | Order code  | Order code  |             |
|------------|--------------|-------------|-----------|-------------|-------------|-------------|
| 1          | 6.0          | G 1/8       | 5/16      | RCPD1-106   | RCPD2-106   |             |
|            | 8.0          |             |           | RCPD1-108   | RCPD2-108   |             |
|            | 10.0         |             |           | RCPD1-110   | RCPD2-110   |             |
|            | 12.0         | G 1/4       | 1/2       | RCPD1-112   | RCPD2-112   |             |
|            | 12.7         |             |           | RCPD1-112.7 | RCPD2-112.7 |             |
|            | 13.5         |             |           | RCPD1-113.5 | RCPD2-113.5 |             |
|            | 14.0         |             |           | RCPD1-114   | RCPD2-114   |             |
|            | 15.0         | G 3/8       | 5/8       | RCPD1-115   | RCPD2-115   |             |
|            | 16.0         |             |           | RCPD1-116   | RCPD2-116   |             |
|            | 17.2         |             |           | RCPD1-117.2 | RCPD2-117.2 |             |
| 18.0       | RCPD1-118    |             |           | RCPD2-118   |             |             |
| 2          | 19.0         | G 1/2       | 3/4       | RCPD1-219   | RCPD2-219   |             |
|            | 20.0         |             |           | RCPD1-220   | RCPD2-220   |             |
|            | 21.3         |             |           | RCPD1-221.3 | RCPD2-221.3 |             |
|            | 22.0         |             |           | RCPD1-222   | RCPD2-222   |             |
|            | 23.0         | G 3/4       | 1         | RCPD1-223   | RCPD2-223   |             |
|            | 25.0         |             |           | RCPD1-225   | RCPD2-225   |             |
|            | 26.9         |             |           | RCPD1-226.9 | RCPD2-226.9 |             |
|            | 28.0         |             |           | RCPD1-228   | RCPD2-228   |             |
|            | 30.0         |             |           | RCPD1-230   | RCPD2-230   |             |
|            | 30.0         |             |           | G 1         | 1 1/4       | RCPD1-330   |
| 32.0       | RCPD1-332    | RCPD2-332   |           |             |             |             |
| 33.7       | RCPD1-333.7  | RCPD2-333.7 |           |             |             |             |
| 35.0       | RCPD1-335    | RCPD2-335   |           |             |             |             |
| 38.0       | G 1 1/4      | 1 1/2       | RCPD1-338 |             |             | RCPD2-338   |
| 40.0       |              |             | RCPD1-340 |             |             | RCPD2-340   |
| 42.0       |              |             | RCPD1-342 | RCPD2-342   |             |             |
| 38.0       |              |             | G 1 1/4   | 1 1/2       | RCPD1-438   | RCPD2-438   |
| 40.0       | RCPD1-440    | RCPD2-440   |           |             |             |             |
| 42.0       | RCPD1-442    | RCPD2-442   |           |             |             |             |
| 45.0       | RCPD1-445    | RCPD2-445   |           |             |             |             |
| 48.3       | G 1 1/2      | 2           |           |             | RCPD1-448.3 | RCPD2-448.3 |
| 50.0       |              |             |           |             | RCPD1-450   | RCPD2-450   |
| 51.0       | G 2          | 2 1/4       |           |             | RCPD1-451   | RCPD2-451   |
| 52.0       |              |             |           |             | RCPD1-452   | RCPD2-452   |
| 55.0       |              |             |           |             | RCPD1-455   | RCPD2-455   |
| 57.0       |              |             |           |             | RCPD1-457   | RCPD2-457   |
| 60.3       |              |             | 2 1/2     | 2 1/2       | RCPD1-460.3 | RCPD2-460.3 |
| 63.0       |              |             |           |             | RCPD1-463   | RCPD2-463   |
| 65.0       | RCPD1-465    | RCPD2-465   |           |             |             |             |
| 70.0       |              |             | RCPD1-470 | RCPD2-470   |             |             |

Continuation see next page ...



Tube clamps series C – Complete range (Continued)

Polypropylene- **RCPD**  
 Inside smooth - **RCPDG<sup>1)</sup>**  
 Polyamide 6 - **RCND**  
 Rubber - **RCVDR\***  
 Aluminium - **RCAD**

(As required please exchange standard abbreviation RCP in column for "Order code")

4 clamp halves, double weld plate, double cover plate, hex. head bolts

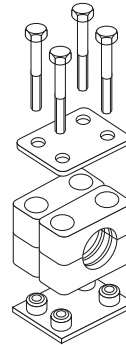

SSC...

DPDC...

RCPD...  
(=2XRCP...)

APDC...

4 clamp halves, double weld plate, double cover plate, socket head bolts

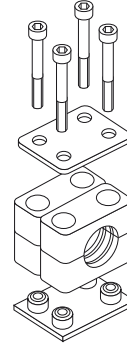

ISC...

DPDC...

RCPD...  
(=2XRCP...)

APDC...

| clamp size | Tube O.D. mm | Tube NB | Tube O.D.  | Order code   | Order code   |
|------------|--------------|---------|------------|--------------|--------------|
| 5          | 70.0         | G 2½    | 3          | RCPD1-570    | RCPD2-570    |
|            | 73.0         |         |            | RCPD1-573    | RCPD2-573    |
|            | 75.0         |         |            | RCPD1-575    | RCPD2-575    |
|            | 76.1         |         |            | RCPD1-576.1  | RCPD2-576.1  |
|            | 80.0         | G 3     | 3¼         | RCPD1-580    | RCPD2-580    |
|            | 82.5         |         |            | RCPD1-582.5  | RCPD2-582.5  |
|            | 88.9         |         |            | RCPD1-588.9  | RCPD2-588.9  |
| 90.0       |              |         | RCPD1-590  | RCPD2-590    |              |
| 6          | 90.0         | G 3½    | 4          | RCPD1-690    | RCPD2-690    |
|            | 97.0         |         |            | RCPD1-697    | RCPD2-697    |
|            | 100.0        |         |            | RCPD1-6100   | RCPD2-6100   |
|            | 101.6        | G 4     | 4¼         | RCPD1-6101.6 | RCPD2-6101.6 |
|            | 108.0        |         |            | RCPD1-6108   | RCPD2-6108   |
|            | 114.3        |         |            | RCPD1-6114.3 | RCPD2-6114.3 |
| 127.0      |              | 5       | RCPD1-6127 | RCPD2-6127   |              |
| 7          | 127.0        | G 5     | 5          | RCPD1-7127   | RCPD2-7127   |
|            | 133.0        |         |            | RCPD1-7133   | RCPD2-7133   |
|            | 140.0        |         |            | RCPD1-7140   | RCPD2-7140   |
|            | 150.0        | G 5½    | 5½         | RCPD1-7150   | RCPD2-7150   |
|            | 152.4        |         |            | RCPD1-7152.4 | RCPD2-7152.4 |
|            | 159.0        |         |            | RCPD1-7159   | RCPD2-7159   |
|            | 165.1        | G 6     | 6¼         | RCPD1-7165.1 | RCPD2-7165.1 |
| 168.3      | RCPD1-7168.3 |         |            | RCPD2-7168.3 |              |
| 8          | 168.3        | G 8     | 6⅝         | RCPD1-8168.3 | RCPD2-8168.3 |
|            | 177.8        |         | 7          | RCPD1-8177.8 | RCPD2-8177.8 |
|            | 193.7        |         | 7⅝         | RCPD1-8193.7 | RCPD2-8193.7 |
|            | 203.0        |         |            | RCPD1-8203   | RCPD2-8203   |
|            | 219.1        |         | 8⅝         | RCPD1-8219.1 | RCPD2-8219.1 |
|            | 220.0        |         |            |              | RCPD1-8220   |

Delivery in unassembled individual components.

<sup>1)</sup> Only sizes 1-4

\* Only with cover plate, hexagon screws and locking washers (only sizes 1-4).

## Tube clamps

### Tube clamp series C with absorbing noise insert

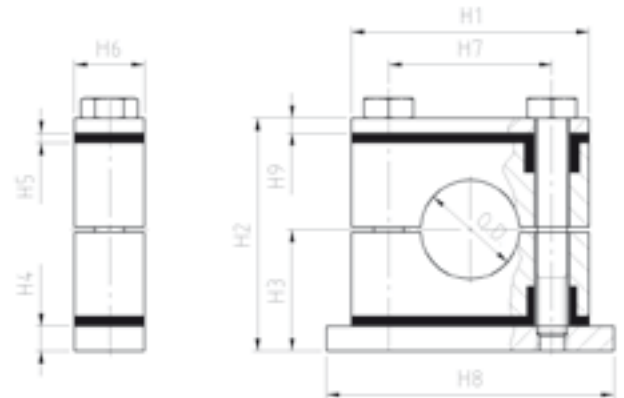

| Clamp size | Tube O.D.mm | Absorbing plate | Weld plate | Bolt ISO 4014 | H1  | H2  | H3 | H4 | H5 | H6 | H7 | H8  | H9 |
|------------|-------------|-----------------|------------|---------------|-----|-----|----|----|----|----|----|-----|----|
| <b>1</b>   | 6.0         | DPEC1X          | APCD1X     | M10X65        | 55  | 69  | 38 | 15 | 7  | 30 | 33 | 70  | 8  |
|            | 8.0         |                 |            |               |     |     |    |    |    |    |    |     |    |
|            | 9.5         |                 |            |               |     |     |    |    |    |    |    |     |    |
|            | 10.0        |                 |            |               |     |     |    |    |    |    |    |     |    |
|            | 12.0        |                 |            |               |     |     |    |    |    |    |    |     |    |
|            | 12.7        |                 |            |               |     |     |    |    |    |    |    |     |    |
|            | 13.5        |                 |            |               |     |     |    |    |    |    |    |     |    |
|            | 14.0        |                 |            |               |     |     |    |    |    |    |    |     |    |
|            | 15.0        |                 |            |               |     |     |    |    |    |    |    |     |    |
|            | 16.0        |                 |            |               |     |     |    |    |    |    |    |     |    |
| 17.2       |             |                 |            |               |     |     |    |    |    |    |    |     |    |
| 18.0       |             |                 |            |               |     |     |    |    |    |    |    |     |    |
| <b>2</b>   | 19.0        | DPEC2X          | APCD2X     | M10X80        | 70  | 85  | 46 | 15 | 7  | 30 | 45 | 85  | 8  |
|            | 20.0        |                 |            |               |     |     |    |    |    |    |    |     |    |
|            | 21.3        |                 |            |               |     |     |    |    |    |    |    |     |    |
|            | 22.0        |                 |            |               |     |     |    |    |    |    |    |     |    |
|            | 23.0        |                 |            |               |     |     |    |    |    |    |    |     |    |
|            | 25.0        |                 |            |               |     |     |    |    |    |    |    |     |    |
|            | 26.9        |                 |            |               |     |     |    |    |    |    |    |     |    |
|            | 28.0        |                 |            |               |     |     |    |    |    |    |    |     |    |
| 30.0       |             |                 |            |               |     |     |    |    |    |    |    |     |    |
| <b>3</b>   | 30.0        | DPEC3X          | APCD3X     | M10X90        | 85  | 97  | 52 | 15 | 7  | 30 | 60 | 100 | 8  |
|            | 32.0        |                 |            |               |     |     |    |    |    |    |    |     |    |
|            | 33.7        |                 |            |               |     |     |    |    |    |    |    |     |    |
|            | 35.0        |                 |            |               |     |     |    |    |    |    |    |     |    |
|            | 38.0        |                 |            |               |     |     |    |    |    |    |    |     |    |
|            | 40.0        |                 |            |               |     |     |    |    |    |    |    |     |    |
| 42.0       |             |                 |            |               |     |     |    |    |    |    |    |     |    |
| <b>4</b>   | 38.0        | DPEC4X          | APCD4X     | M12X130       | 115 | 134 | 72 | 20 | 7  | 45 | 90 | 140 | 10 |
|            | 40.0        |                 |            |               |     |     |    |    |    |    |    |     |    |
|            | 42.0        |                 |            |               |     |     |    |    |    |    |    |     |    |
|            | 45.0        |                 |            |               |     |     |    |    |    |    |    |     |    |
|            | 48.3        |                 |            |               |     |     |    |    |    |    |    |     |    |
|            | 50.0        |                 |            |               |     |     |    |    |    |    |    |     |    |
|            | 51.0        |                 |            |               |     |     |    |    |    |    |    |     |    |
|            | 52.0        |                 |            |               |     |     |    |    |    |    |    |     |    |
|            | 54.0        |                 |            |               |     |     |    |    |    |    |    |     |    |
|            | 55.0        |                 |            |               |     |     |    |    |    |    |    |     |    |
|            | 57.0        |                 |            |               |     |     |    |    |    |    |    |     |    |
|            | 60.3        |                 |            |               |     |     |    |    |    |    |    |     |    |
|            | 63.5        |                 |            |               |     |     |    |    |    |    |    |     |    |
|            | 65.0        |                 |            |               |     |     |    |    |    |    |    |     |    |
| 70.0       |             |                 |            |               |     |     |    |    |    |    |    |     |    |



Tube clamp series C with absorbing noise insert

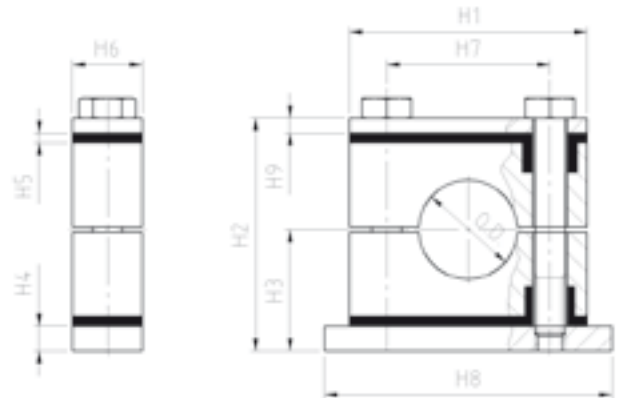

| Clamp size | Tube O.D.mm | Absorbing plate | Weld plate | Bolt ISO 4014 | H1  | H2  | H3  | H4 | H5 | H6  | H7  | H8  | H9 |
|------------|-------------|-----------------|------------|---------------|-----|-----|-----|----|----|-----|-----|-----|----|
| <b>5</b>   | 70.0        | DPEC5X          | APCD5X     | M16X160       | 152 | 165 | 90  | 25 | 7  | 60  | 122 | 180 | 10 |
|            | 73.0        |                 |            |               |     |     |     |    |    |     |     |     |    |
|            | 75.0        |                 |            |               |     |     |     |    |    |     |     |     |    |
|            | 76.1        |                 |            |               |     |     |     |    |    |     |     |     |    |
|            | 80.0        |                 |            |               |     |     |     |    |    |     |     |     |    |
|            | 82.5        |                 |            |               |     |     |     |    |    |     |     |     |    |
|            | 88.9        |                 |            |               |     |     |     |    |    |     |     |     |    |
| 90.0       |             |                 |            |               |     |     |     |    |    |     |     |     |    |
| <b>6</b>   | 90.0        | DPEC6X          | APCD6X     | M20X230       | 205 | 237 | 126 | 30 | 11 | 80  | 168 | 228 | 15 |
|            | 97.0        |                 |            |               |     |     |     |    |    |     |     |     |    |
|            | 100.0       |                 |            |               |     |     |     |    |    |     |     |     |    |
|            | 101.6       |                 |            |               |     |     |     |    |    |     |     |     |    |
|            | 108.0       |                 |            |               |     |     |     |    |    |     |     |     |    |
|            | 114.3       |                 |            |               |     |     |     |    |    |     |     |     |    |
| 127.0      |             |                 |            |               |     |     |     |    |    |     |     |     |    |
| <b>7</b>   | 127.0       | DPEC7X          | APCD7X     | M24X260       | 250 | 287 | 161 | 50 | 11 | 90  | 205 | 270 | 15 |
|            | 130.0       |                 |            |               |     |     |     |    |    |     |     |     |    |
|            | 133.0       |                 |            |               |     |     |     |    |    |     |     |     |    |
|            | 140.0       |                 |            |               |     |     |     |    |    |     |     |     |    |
|            | 141.3       |                 |            |               |     |     |     |    |    |     |     |     |    |
|            | 150.0       |                 |            |               |     |     |     |    |    |     |     |     |    |
|            | 152.4       |                 |            |               |     |     |     |    |    |     |     |     |    |
|            | 159.0       |                 |            |               |     |     |     |    |    |     |     |     |    |
|            | 165.1       |                 |            |               |     |     |     |    |    |     |     |     |    |
| 168.3      |             |                 |            |               |     |     |     |    |    |     |     |     |    |
| <b>8</b>   | 168.3       | DPEC8X          | APCD8X     | M30X360       | 322 | 407 | 231 | 80 | 16 | 120 | 265 | 340 | 25 |
|            | 177.8       |                 |            |               |     |     |     |    |    |     |     |     |    |
|            | 193.7       |                 |            |               |     |     |     |    |    |     |     |     |    |
|            | 203.0       |                 |            |               |     |     |     |    |    |     |     |     |    |
|            | 219.1       |                 |            |               |     |     |     |    |    |     |     |     |    |
|            | 220.0       |                 |            |               |     |     |     |    |    |     |     |     |    |







## Pipes and tubes

ENGINEERING YOUR SUCCESS.

### Table of contents

|  |     |
|--|-----|
| Technical properties, calculation rules and standards.....   | 257 |
| Tubes and pipes for piping business  |     |
| EO steel tubes, seamless, metric sizes, material E235+N<br>for marine and offshore applications.....               | 261 |
| EO steel tubes, seamless, metric sizes, material E235+N<br>for landbased and industrial applications.....          | 262 |
| EO steel tubes, seamless, metric sizes, material E355+N<br>for marine and offshore applications.....               | 263 |
| EO steel tubes, seamless, metric sizes, material E355+N<br>for landbased and industrial applications.....          | 264 |
| EO stainless steel tubes, metric sizes, ASTM A269, material 316L<br>for marine and offshore applications.....      | 265 |
| EO stainless steel tubes, metric sizes, ASTM A269, material 316L<br>for landbased and industrial applications..... | 266 |
| EO stainless steel pipes, scheduled sizes, ASTM A312, material 316L<br>for marine and offshore applications.....   | 267 |
| Attachement.....   | 268 |

## Tube and pipe specification

### Recommended carbon steel tubes and pipes

Parker recommends the use of cold drawn seamless hydraulic tubes and pipes acc. to DIN EN 10305-4.

E 355N (St. 52.4 NBK) or E 235N (St. 37.4 NBK).

- |                             |  |
|-----------------------------|--|
| + precision dimension/shape | + clean inside (no scale)                      |
| + high pressure capability  | + excellent scaling surface after roll flaring |

### Recommended stainless steel tubes and pipes

Parker recommends the use of seamless cold drawn stainless steel tubes and pipes acc. to

DIN EN 10216-5

ASTM A269/A213

ASTM A312

- |                             |  |
|-----------------------------|--|
| + precision dimension/shape | + excellent scaling surface after roll flaring |
| + high pressure capability  |  |

### Welded tubes and pipes

Tubes and pipes acc. to above specification but welded and cold redrawn instead of seamless drawn are usually suitable. Pressure capability might be reduced due to the welding seam zone. Welding seam quality might effect roll flaring surface results.

### Hot rolled pipes

Hot rolled pipes are not recommended for the following reasons:

Hot rolled pipes do not have precision dimensions and may slip in machine dies.

They have scales inside and outside. The inside scales effect the cleanliness level of the fluid and reduces fatigue levels.

Used in roll flaring process the scales will contaminate the flaring tools (high cleaning effort) and cause poor flare surface quality.

**The permitted maximum working pressure is calculated either acc. to DNV, DIN or ANSI.**

## Material Specifications & Values

### 1.0308 (E235/St.35.4) acc. to DIN EN 10305-4

|                     |                                     |
|---------------------|-------------------------------------|
| Tensile strength    | min 340 N/mm <sup>2</sup>           |
| Yield strength      | min 235 N/mm <sup>2</sup>           |
| Fatigue strength    | 225 N/mm <sup>2</sup> <sup>1)</sup> |
| Elongation at break | min. 25%                            |

### 1.0508 (E355/St.52.4) acc. to DIN EN 10305-4

|                     |                           |
|---------------------|---------------------------|
| Tensile strength    | min 490 N/mm <sup>2</sup> |
| Yield strength      | min 355 N/mm <sup>2</sup> |
| Fatigue strength    | 265 N/mm <sup>2</sup>     |
| Elongation at break | min. 22 %                 |

### 1.4571 (316 Ti) cold drawn (CFA)<sup>3)</sup> acc. to DIN EN 10216-5

|                     |                           |
|---------------------|---------------------------|
| Tensile strength    | min 500 N/mm <sup>2</sup> |
| 0.2 % proof stress  | min 210 N/mm <sup>2</sup> |
| 1 % proof stress    | min 245 N/mm <sup>2</sup> |
| Fatigue strength    | 220 N/mm <sup>2</sup>     |
| Elongation at break | min. 35 %                 |

### 1.4404 (316L) cold drawn (CFA)<sup>3)</sup> acc. to DIN EN 10216-5

|                     |                           |
|---------------------|---------------------------|
| Tensile strength    | min 500 N/mm <sup>2</sup> |
| 0.2 % proof stress  | min 210 N/mm <sup>2</sup> |
| 1 % proof stress    | min 245 N/mm <sup>2</sup> |
| Elongation at break | min. 35 %                 |

### 1.4401 (316) acc. to DIN EN 10216-5

|                     |                           |
|---------------------|---------------------------|
| Tensile strength    | min 510 N/mm <sup>2</sup> |
| 0.2 % proof stress  | min 205 N/mm <sup>2</sup> |
| 1 % proof stress    | min 240 N/mm <sup>2</sup> |
| Elongation at break | min. 40 %                 |

### 1.4301 (304) acc. to DIN EN 10216-5

|                     |                                     |
|---------------------|-------------------------------------|
| Tensile strength    | min 500 N/mm <sup>2</sup>           |
| 0.2 % proof stress  | min 195 N/mm <sup>2</sup>           |
| 1 % proof stress    | min 230 N/mm <sup>2</sup>           |
| Fatigue strength    | 195 N/mm <sup>2</sup> <sup>2)</sup> |
| Elongation at break | min. 40 %                           |

### 1.4404 (316L) ASTM A269 / A213

|  |                           |
|--|---------------------------|
| Tensile strength                       | min 530 N/mm <sup>2</sup> |
| Yield strength                         | min 276 N/mm <sup>2</sup> |
| 0.2 % proof stress / 1.6 <sup>4)</sup> | 172.5 N/mm <sup>2</sup>   |

### 1.4404 (316L) ASTM A312 / A530

|  |                           |
|--|---------------------------|
| Tensile strength                       | min 515 N/mm <sup>2</sup> |
| Yield strength                         | min 234 N/mm <sup>2</sup> |
| 0.2 % proof stress / 1.6 <sup>4)</sup> | 146 N/mm <sup>2</sup>     |

<sup>1)</sup> DIN 2413 Template, Tab. 4

<sup>2)</sup> Rollof/Matek ME Ausg. 14, (no standard value)

<sup>3)</sup> Strength increase due to cold forming following 1.4571

<sup>4)</sup> Pressure rating calculation based on this mechanical properties require certification according to 3.1 - EN 10204 that confirms the mechanical properties.

### Tube calculation for marine and offshore acc. to DNV rules

Calculation of working pressure of steel and stainless steel tubes for ship building acc. to DNV Part 4, Chapter 6, Section 6.

$$P = \frac{20 \cdot \sigma_t \cdot e \cdot t_0}{D - t_0}$$

P = permissible working pressure [bar]  
 $\sigma_t$  = permissible stress [N/mm<sup>2</sup>]  
 calculated from the lower value off:

|   |   |
|---|---|
| stainless steel:                                | carbon steel:                                   |
| $\sigma_t = \frac{R_m}{2.7}$ or $\frac{K}{1.6}$ | $\sigma_t = \frac{R_m}{2.7}$ or $\frac{K}{1.8}$ |

$t_0$  = tube wall thickness without allowances [mm]

$$t_0 = t_n \cdot a - c - b$$

$t_n$  = tube wall thickness nominal [mm]

a = factor for wall thickness allowance [mm]  
 = 0.8 for Tube-OD 4-5, 0.85 for Tube-OD 6-8, 0.9 for Tube OD  $\geq 10$   
 = 0.9 for all stainless steel tubes

$$b = 0.1333 \cdot t_0 \text{ (at } R/D=3) \rightarrow t_0 = \frac{t_n \cdot a - c}{1.1333}$$

b = bending allowance

c = corrosion tolerance, c = 0.3 mm for hydraulic steel tube, c = 0 mm for SS tubes

e = strength ratio: for seamless tubes e = 1

D = tube outside diameter [mm]

$R_m$  = min. tensile strength [N/mm<sup>2</sup>]

K = min. yield strength or min 0.2% proof stress [N/mm<sup>2</sup>]

### Tube calculation for landbased and industrial applications acc. to DIN rules

#### DIN 2413 I, only for static load

Calculation of working pressure of steel tubes for static stress up to 120°C. Corrosion – additional allowances are not considered for the calculation of pressures. Tubes with a diameter of OD/ID > 2 are calculated for static stress in accordance with DIN 2413 III, but with K = yield strength.

$$P = \frac{20 \cdot K \cdot s \cdot c}{S \cdot D}$$

P = permissible working pressure [bar]  
 K = yield strength [N/mm<sup>2</sup>]  
 s = tube wall thickness [mm]  
 c = factor for wall thickness allowance  
 = 0.8 for Tube-OD 4-5, 0.85 for Tube-OD 6-8,  
 0.9 for Tube-OD 10  
 = 0.9 for all stainless steel tubes  
 S = Safety factor = 1.5  
 D = tube outside diameter [mm]

#### DIN 2413 III, for dynamic load

Calculation of working pressure of steel tubes for dynamic stress up to 120°C. Corrosion – additional allowances are not considered for the calculation of pressures.

$$P = \frac{20 \cdot K \cdot s \cdot c}{S \cdot (D + s \cdot c)}$$

P = permissible working pressure [bar]  
 K = fatigue strength [N/mm<sup>2</sup>]  
 s = tube wall thickness [mm]  
 c = factor for wall thickness allowance  
 = 0.8 for Tube-OD 4-5, 0.85 for Tube-OD 6-8,  
 0.9 for Tube-OD 10-80  
 = 0.9 for all stainless steel tubes  
 S = Safety factor = 1.5  
 D = tube outside diameter [mm]

#### Burst Pressure calculation

Calculation acc. to Formula of DIN 2413 but without safety

BP = Burst Pressure  
 $R_m$  = min tensile strength  
 s = tube wall thickness  
 c = factor for wall thickness allowance  
 = 0.8 for Tube-OD 4-5,  
 0.85 for Tube-OD 6-8,  
 0.9 for Tube-OD 10  
 0.9 for all stainless steel tubes  
 D = tube outside diameter [mm]

$$BP = \frac{20 \cdot R_m \cdot s \cdot c}{D}$$



## Pressure reductions and temperatures

Required pressure reductions (depending on the material) with reference to the catalogue pressures for higher temperatures. Both metal fitting material and elastomeric sealing compound have to be selected according to the temperature range of the system. DNV may require different pressure reduction based on application

| Material                             | Pressure reduction of permissible operating temperatures TB in °C |     |     |     |     |     |        |      |         |       |         |      |       |       |      |       |
|--------------------------------------|---|-----|-----|-----|-----|-----|--------|------|---------|-------|---------|------|-------|-------|------|-------|
|                                      | -60   | -54 | -40 | -35 | -25 | +20 | +50    | +100 | +120    | +150  | +175    | +200 | +250  | +300  | +400 |       |
| Steel components                     |   |     | 0 % |     |     |     |        |      | -11 %   |       | -19 %   |      | -28 % |       |      |       |
| Steel, tubes                         |   |     | 0 % |     |     |     |        |      |         |       | -19 %   |      | -27 % |       |      |       |
| Stainless steel components           | 0 %   |     |     |     |     |     | -11 %  |      |         | -20 % |         |      | -30 % |       |      |       |
| Stainless steel, tubes               | 0 %   |     |     |     |     |     | -5.5 % |      | -11.5 % |       | -21.5 % |      |       | -29 % |      | -34 % |
| Sealing material NBR (e.g. Perbunan) |   |     |     |     |     |     |        |      |         |       |         |      |       |       |      |       |
| Sealing material FKM                 |   |     |     |     |     |     |        |      |         |       |         |      |       |       |      |       |
| Sealing material Polyurethan (P5008) |   |     |     |     |     |     |        |      |         |       |         |      |       |       |      |       |

- Permissible operating temperature
- Ambient temperature of hydraulic and pneumatic applications
- Temperature not permissible

Calculation example:  
 Temperature = 200°C  
 Material = Stainless steel  
 Pressure reduction = 29%  
 Pressure reduction tubes = 21.5%  
 PN tube 16x2.5/71. DIN2413 III = 362 bar

Formula:

$$PN_{200^{\circ}\text{C}} = \frac{400 \text{ bar}}{100\%} \times (100\% - 29\%) = 284 \text{ bar}$$

$$PN_{\text{tube } 200^{\circ}\text{C}} = \frac{362 \text{ bar}}{100\%} \times (100\% - 21.5\%) = 284 \text{ bar}$$

## Flow diameter of tube lines

### Determining tube sizes for hydraulic systems

Proper tube material, type and size for a given application and type of fitting are critical for efficient and trouble-free operation of the fluid system. Selection of proper tubing involves choosing the right tube material, and determining the optimum tube size (O.D. and wall thickness).

Proper sizing of the tube for various parts of a hydraulic system results in an optimum combination of efficient and cost effective performance.

A tube that is too small causes high fluid velocity, which has many detrimental effects. In pressure lines, it causes high friction losses and turbulence, both resulting in high pressure drops and heat generation. High heat accelerates wear in moving parts and rapid aging of seals and hoses, all resulting in reduced component life. High heat generation also means wasted energy, and hence, low efficiency.

Too large tubes increase system cost. Thus, optimum tube sizing is very critical. The following is a simple procedure for sizing tubes.

### Determine required flow diameter

Use table to determine recommended flow diameter for the required flow rate and type of line.

The table is based on the following recommended flow rates that are common in the shipbuilding and offshore engineering:

$$\begin{aligned} \text{Pressure lines} & - 3 \rightarrow 7.2 \left[ \frac{\text{m}}{\text{s}} \right] \\ \text{Return lines} & - 2 \rightarrow 4.5 \left[ \frac{\text{m}}{\text{s}} \right] \\ \text{Suction lines} & - 1 \rightarrow 1.8 \left[ \frac{\text{m}}{\text{s}} \right] \end{aligned}$$

Avoid flow rates > 8 m/s!

The resulting forces are high and can destroy the tube lines.

If you desire to use different velocities than the above, use the following formula to determine the required flow diameter.

$$\text{Tube - I.D. [mm]} = 4,61 \times \sqrt{\frac{\text{Flow} \left[ \frac{\text{ltr.}}{\text{min}} \right]}{\text{Velocity} \left[ \frac{\text{m}}{\text{s}} \right]}}$$

### Determine required wall thickness

Use tube/pressure calculation tables shown in the tube chapter to determine recommended wall thickness for the required working pressure and flow diameter of the line. Therefore choose a working pressure which is equal or higher than the required working pressure.

## Flow characteristics

Hydraulic systems are in most cases only rated with a flow velocity defined on the basis of experience. The pressure losses in lines are not taken into account, or measured later on when testing the system. As the pressure losses increase proportionally greater than the flow resistance, it is important to achieve the best rating of the system, so that they are already taken into account when planning the tube connections. Calculation is not as difficult as it is often thought, and this chapter is intended to provide a guideline. Besides, it provides information on how excessive pressure losses can be avoided, because pressure losses result in losses in performance and excessive heat. Noise occurs and possibly cavitation in suction lines.

### Medium

All indication given with regard to flow restrictions and to flow properties refer exclusively to liquids. For gaseous media, the variable density of the gas must additionally be taken into account.

### Units

$$c = \text{Flow velocity} \left[ \frac{\text{m}}{\text{s}} \right]$$

$$d = \text{Pipe inside diameter [m]}$$

$$L = \text{Pipe length [m]}$$

$$p = \text{Pressure [Pa], 1 bar = 100000 Pa}$$

$$\dot{V} = \text{Flow rate} \left[ \frac{\text{m}^3}{\text{s}} \right], 1 \frac{\text{m}^3}{\text{s}} = 6000 \frac{\text{l}}{\text{min}}$$

$$\lambda = \text{Pipe friction factor}$$

$$v(T) = \text{Kinematic viscosity of the medium depending on temperature} \left[ \frac{\text{m}^2}{\text{s}} \right]$$

$$\rho(T) = \text{Density of the medium depending on temperature} \left[ \frac{\text{kg}}{\text{m}^3} \right]$$

$$\zeta = \text{Individual pressure loss coefficient}$$

Only base units have been used. This has the advantage that the formula do not contain correction factors and there is no danger of confusion, e.g. that values are used with the wrong unit. In case values are given in other units – the flow rate is e.g. often given in l/min – it is advisable to convert them into the base units before starting calculation.

### Pressure losses in pipe lines

To calculate pressure losses in pipe lines, it must first be determined whether there is a laminar or a turbulent flow. Laminar flow is homogenous and without turbulence. In case of turbulent flow, the losses increase much more quickly.

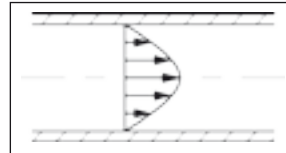

Flow profile with laminar flow

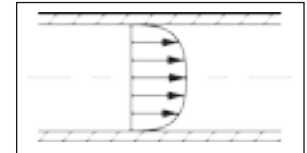

Flow profile with turbulent flow

The kind of flow is defined by the Reynolds' number. With a Reynolds' number of more than 2320, the flow changes to turbulent. The Reynolds' number is calculated according to the formula:

$$Re = \frac{c \cdot d}{v(T)}$$

The Reynolds' number is a non-dimensional number. The critical fluid velocity at which the flow regime can change, is thus calculated from:

$$c_{cr} = 2320 \cdot \frac{v(T)}{d} \left[ \frac{\text{m}}{\text{s}} \right]$$

With a given flow rate, the fluid velocity can be calculated according to the formula:

$$c = \frac{\dot{V} \cdot 4}{d^2 \cdot \pi} \left[ \frac{\text{m}}{\text{s}} \right]$$

Subsequently, the pipe friction factor  $\lambda$  can be calculated. The pipe friction factor  $\lambda$  is a function of the Reynolds' number and also depends on the roughness of the pipe. As hydraulically smooth pipes can generally be assumed in hydraulic applications, the pipe friction factor  $\lambda$  is calculated according to the following formula:

$$\text{laminar flow, (Re < 2320): } \lambda = \frac{64}{Re}$$

$$\text{turbulent flow, (Re > 2320): } \lambda = \frac{0.3164}{\sqrt[4]{Re}}$$

Finally, if all factors are known, the pressure loss in a certain pipe line can be calculated according to the formula:

$$\Delta p = \lambda \cdot \frac{L}{d} \cdot \frac{\rho(T) \cdot c^2}{2} \text{ [Pa]}$$

### Calculation of individual losses

A hydraulic system does not only incorporate pipes, but also valves, fittings, pipe bends etc. that cause flow losses. These individual losses are often much higher than the pipe losses and are calculated according to the following formula:

$$\Delta p = \zeta \cdot \rho(T) \cdot \frac{c^2}{2} \text{ [Pa]}$$



## Tubes – Marine and offshore applications (DNV Rules)

1 DNV Bended pipe including manufacturing and corrosion tolerances

2 DNV Straight pipe including manufacturing and corrosion tolerances

3 Burst pressure (B.P.) calculation including manufacturing tolerance

### Tube E 235N /St. 37.4 NBK - Cr(VI)-free plated or phosphated and oiled

| Tube<br>O.D. x W.T. | 1<br>DNV<br>W.P. bar | 2<br>DNV<br>W.P. bar | 3<br>B.P. bar | Weight<br>kg/mtr. | Phosphated<br>and oiled<br>Order code | Cr(VI)-free<br>Order code |
|---------------------|----------------------|----------------------|---------------|-------------------|---------------------------------------|---------------------------|
| 06x1.0              | 230                  | 373                  | 1105          | 0.07              | <b>R06x1</b>                          | <b>R06x1CF</b>            |
| 06X1.5              | 437                  | 506                  | 1658          | 0.17              | <b>R06X1.5</b>                        | <b>R06X1.5CF</b>          |
| 08X1.0              | 169                  | 193                  | 829           | 0.17              | <b>R08X1</b>                          | <b>R08X1CF</b>            |
| 08X1.5              | 315                  | 362                  | 1243          | 0.24              | <b>R08X1.5</b>                        | <b>R08X1.5CF</b>          |
| 10X1.0              | 146                  | 167                  | 702           | 0.22              | <b>R10X1</b>                          | <b>R10X1CF</b>            |
| 10X1.5              | 267                  | 306                  | 1053          | 0.31              | <b>R10X1.5</b>                        | <b>R10X1.5CF</b>          |
| 12X1.5              | 218                  | 250                  | 878           | 0.39              | <b>R12X1.5</b>                        | <b>R12X1.5CF</b>          |
| 12X2.0              | 324                  | 373                  | 1170          | 0.49              | <b>R12X2</b>                          | <b>R12X2CF</b>            |
| 14X2.0              | 273                  | 313                  | 1003          | 0.59              | <b>R14X2</b>                          | <b>R14X2CF</b>            |
| 15X1.5              | 172                  | 196                  | 702           | 0.50              | <b>R15X1.5</b>                        | <b>R15X1.5CF</b>          |
| 15X2.0              | 253                  | 290                  | 936           | 0.64              | <b>R15X2</b>                          | <b>R15X2CF</b>            |
| 16X1.5              | 160                  | 183                  | 658           | 0.54              | <b>R16X1.5</b>                        | <b>R16X1.5CF</b>          |
| 16X2.0              | 235                  | 270                  | 878           | 0.69              | <b>R16X2</b>                          | <b>R16X2CF</b>            |
| 16X2.5              | 315                  | 362                  | 1097          | 0.83              | <b>R16X2.5</b>                        | <b>R16X2.5CF</b>          |
| 18X1.5              | 142                  | 162                  | 585           | 0.61              | <b>R18X1.5</b>                        | <b>R18X1.5CF</b>          |
| 18X2.0              | 207                  | 237                  | 780           | 0.79              | <b>R18X2</b>                          | <b>R18X2CF</b>            |
| 20X2.0              | 185                  | 212                  | 702           | 0.89              | <b>R20X2</b>                          | <b>R20X2CF</b>            |
| 20X2.5              | 246                  | 282                  | 878           | 1.08              | <b>R20X2.5</b>                        | <b>R20X2.5CF</b>          |
| 20X3.0              | 309                  | 356                  | 1053          | 1.26              | <b>R20X3</b>                          | <b>R20X3CF</b>            |
| 20X4.0              | 445                  | 516                  | 1404          | 1.58              |                                       | <b>R20X4CF</b>            |
| 22X1.5              | 115                  | 131                  | 479           | 0.76              | <b>R22X1.5</b>                        | <b>R22X1.5CF</b>          |
| 22X2.0              | 167                  | 191                  | 638           | 0.99              | <b>R22X2</b>                          | <b>R22X2CF</b>            |
| 22X2.5              | 221                  | 254                  | 798           | 1.20              | <b>R22x2.5</b>                        | <b>R22X2.5CF</b>          |
| 25X2.0              | 146                  | 167                  | 562           | 1.13              | <b>R25X2</b>                          | <b>R25X2CF</b>            |
| 25X2.5              | 193                  | 221                  | 702           | 1.39              | <b>R25X2.5</b>                        | <b>R25X2.5CF</b>          |
| 25X3.0              | 242                  | 277                  | 842           | 1.63              | <b>R25X3</b>                          | <b>R25X3CF</b>            |
| 25X4.0              | 344                  | 397                  | 1123          | 2.07              | <b>R25X4</b>                          | <b>R25X4CF</b>            |
| 28X2.0              | 129                  | 148                  | 501           | 1.28              | <b>R28X2</b>                          | <b>R28X2CF</b>            |
| 28X3.0              | 214                  | 245                  | 752           | 1.85              | <b>R28X3</b>                          | <b>R28X3CF</b>            |
| 30X2.0              | 120                  | 137                  | 468           | 1.38              |                                       | <b>R30X2CF</b>            |
| 30X3.0              | 198                  | 227                  | 702           | 2.00              | <b>R30X3</b>                          | <b>R30X3CF</b>            |
| 30X4.0              | 281                  | 323                  | 936           | 2.56              | <b>R30X4</b>                          | <b>R30X4CF</b>            |
| 30X5.0              | 368                  | 425                  | 1170          | 3.08              | <b>R30X5</b>                          | <b>R30X5CF</b>            |
| 35X2.0              | 103                  | 117                  | 401           | 1.63              | <b>R35X2</b>                          | <b>R35X2CF</b>            |
| 35X3.0              | 168                  | 192                  | 602           | 2.37              | <b>R35X3</b>                          | <b>R35X3CF</b>            |
| 38X2.5              | 124                  | 141                  | 462           | 2.19              |                                       | <b>R38X2.5CF</b>          |
| 38X3.0              | 154                  | 176                  | 554           | 2.59              | <b>R38X3</b>                          | <b>R38X3CF</b>            |
| 38X4.0              | 217                  | 248                  | 739           | 3.35              | <b>R38X4</b>                          | <b>R38X4CF</b>            |
| 38X5.0              | 282                  | 324                  | 924           | 4.07              | <b>R38X5</b>                          | <b>R38X5CF</b>            |
| 42X2.0              | 85                   | 97                   | 334           | 1.97              | <b>R42X2</b>                          | <b>R42X2CF</b>            |
| 42X3.0              | 139                  | 158                  | 501           | 2.89              | <b>R42X3</b>                          | <b>R42X3CF</b>            |
| 42X4.0              | 194                  | 223                  | 669           | 3.75              | <b>R42X4</b>                          | <b>R42X4CF</b>            |
| 50X3.0              | 115                  | 132                  | 421           | 3.48              | <b>R50X3</b>                          | <b>R50X3CF</b>            |
| 60X3.0              | 95                   | 109                  | 351           | 4.22              | <b>R60X3</b>                          | <b>R60X3CF</b>            |
| 75X3.0              | 76                   | 86                   | 281           | 5.32              | <b>R75X3</b>                          | <b>R75X3CF</b>            |
| 90X3.5              | 75                   | 85                   | 273           | 7.47              | <b>R90X3.5</b>                        | <b>R90X3.5CF</b>          |
| 100X4.0             | 78                   | 89                   | 281           | 9.47              | <b>R100X4</b>                         |                           |
| 115X4.0             | 68                   | 77                   | 244           | 10.98             | <b>R115X4</b>                         |                           |
| 140X4.5             | 63                   | 72                   | 226           | 15.04             | <b>R140X4.5</b>                       |                           |
| 165X5.0             | 60                   | 68                   | 213           | 19.73             | <b>R165X5</b>                         |                           |
| 220X6.0             | 55                   | 62                   | 191           | 31.66             | <b>R220X6</b>                         |                           |
| 273X6.0             | 44                   | 50                   | 154           | 39.51             | <b>R273X6</b>                         |                           |

Other sizes on request

## Tubes – Landbased and industrial applications (DIN Rules)

- 1 DIN 2413 I static pressure (W.P.) capability for straight pipe including manufacturing tolerance  
 2 DIN 2413 III dynamic pressure (W.P.) capability for straight pipe including manufacturing tolerance  
 3 Burst pressure (B.P.) calculation including manufacturing tolerance

### Tube E 235N /St. 37.4 NBK - Cr(VI)-free plated or phosphated and oiled

| Tube<br>O.D. x W.T. | 1<br>DIN 2413 I<br>W.P. bar | 2<br>DIN 2413 III<br>W.P. bar | 3<br>B.P. bar | Weight<br>kg/mtr. | Phosphated<br>and oiled<br>Order code | Cr(VI)-free<br>Order code |
|---------------------|-----------------------------|-------------------------------|---------------|-------------------|---------------------------------------|---------------------------|
| 06x1.0              | 444                         | 372                           | 1105          | 0.07              | <b>R06x1</b>                          | <b>R06x1CF</b>            |
| 06X1.5              | 666                         | 526                           | 1658          | 0.17              | <b>R06X1.5</b>                        | <b>R06X1.5CF</b>          |
| 08X1.0              | 333                         | 288                           | 829           | 0.17              | <b>R08X1</b>                          | <b>R08X1CF</b>            |
| 08X1.5              | 499                         | 412                           | 1243          | 0.24              | <b>R08X1.5</b>                        | <b>R08X1.5CF</b>          |
| 10X1.0              | 282                         | 248                           | 702           | 0.22              | <b>R10X1</b>                          | <b>R10X1CF</b>            |
| 10X1.5              | 423                         | 357                           | 1053          | 0.31              | <b>R10X1.5</b>                        | <b>R10X1.5CF</b>          |
| 12X1.5              | 353                         | 303                           | 878           | 0.39              | <b>R12X1.5</b>                        | <b>R12X1.5CF</b>          |
| 12X2.0              | 470                         | 391                           | 1170          | 0.49              | <b>R12X2</b>                          | <b>R12X2CF</b>            |
| 14X2.0              | 403                         | 342                           | 1003          | 0.59              | <b>R14X2</b>                          | <b>R14X2CF</b>            |
| 15X1.5              | 282                         | 248                           | 702           | 0.50              | <b>R15X1.5</b>                        | <b>R15X1.5CF</b>          |
| 15X2.0              | 376                         | 321                           | 936           | 0.64              | <b>R15X2</b>                          | <b>R15X2CF</b>            |
| 16X1.5              | 264                         | 233                           | 658           | 0.54              | <b>R16X1.5</b>                        | <b>R16X1.5CF</b>          |
| 16X2.0              | 353                         | 303                           | 878           | 0.69              | <b>R16X2</b>                          | <b>R16X2CF</b>            |
| 16X2.5              | 441                         | 370                           | 1097          | 0.83              | <b>R16X2.5</b>                        | <b>R16X2.5CF</b>          |
| 18X1.5              | 235                         | 209                           | 585           | 0.61              | <b>R18X1.5</b>                        | <b>R18X1.5CF</b>          |
| 18X2.0              | 313                         | 273                           | 780           | 0.79              | <b>R18X2</b>                          | <b>R18X2CF</b>            |
| 20X2.0              | 282                         | 248                           | 702           | 0.89              | <b>R20X2</b>                          | <b>R20X2CF</b>            |
| 20X2.5              | 353                         | 303                           | 878           | 1.08              | <b>R20X2.5</b>                        | <b>R20X2.5CF</b>          |
| 20X3.0              | 423                         | 357                           | 1053          | 1.26              | <b>R20X3</b>                          | <b>R20X3CF</b>            |
| 20X4.0              | 564                         | 458                           | 1404          | 1.58              |                                       | <b>R20X4CF</b>            |
| 22X1.5              | 192                         | 173                           | 479           | 0.76              | <b>R22X1.5</b>                        | <b>R22X1.5CF</b>          |
| 22X2.0              | 256                         | 227                           | 638           | 0.99              | <b>R22X2</b>                          | <b>R22X2CF</b>            |
| 22X2.5              | 320                         | 278                           | 798           | 1.20              | <b>R22x2.5</b>                        | <b>R22X2.5CF</b>          |
| 25X2.0              | 226                         | 201                           | 562           | 1.13              | <b>R25X2</b>                          | <b>R25X2CF</b>            |
| 25X2.5              | 282                         | 248                           | 702           | 1.39              | <b>R25X2.5</b>                        | <b>R25X2.5CF</b>          |
| 25X3.0              | 338                         | 292                           | 842           | 1.63              | <b>R25X3</b>                          | <b>R25X3CF</b>            |
| 25X4.0              | 451                         | 378                           | 1123          | 2.07              | <b>R25X4</b>                          | <b>R25X4CF</b>            |
| 28X2.0              | 201                         | 181                           | 501           | 1.28              | <b>R28X2</b>                          | <b>R28X2CF</b>            |
| 28X3.0              | 302                         | 264                           | 752           | 1.85              | <b>R28X3</b>                          | <b>R28X3CF</b>            |
| 30X2.0              | 188                         | 170                           | 468           | 1.38              |                                       | <b>R30X2CF</b>            |
| 30X3.0              | 282                         | 248                           | 702           | 2.00              | <b>R30X3</b>                          | <b>R30X3CF</b>            |
| 30X4.0              | 376                         | 321                           | 936           | 2.56              | <b>R30X4</b>                          | <b>R30X4CF</b>            |
| 30X5.0              | 470                         | 391                           | 1170          | 3.08              | <b>R30X5</b>                          | <b>R30X5CF</b>            |
| 35X2.0              | 161                         | 147                           | 401           | 1.63              | <b>R35X2</b>                          | <b>R35X2CF</b>            |
| 35X3.0              | 242                         | 215                           | 602           | 2.37              | <b>R35X3</b>                          | <b>R35X3CF</b>            |
| 38X2.5              | 186                         | 168                           | 462           | 2.19              |                                       | <b>R38X2.5CF</b>          |
| 38X3.0              | 223                         | 199                           | 554           | 2.59              | <b>R38X3</b>                          | <b>R38X3CF</b>            |
| 38X4.0              | 297                         | 260                           | 739           | 3.35              | <b>R38X4</b>                          | <b>R38X4CF</b>            |
| 38X5.0              | 371                         | 318                           | 924           | 4.07              | <b>R38X5</b>                          | <b>R38X5CF</b>            |
| 42X2.0              | 134                         | 123                           | 334           | 1.97              | <b>R42X2</b>                          | <b>R42X2CF</b>            |
| 42X3.0              | 201                         | 181                           | 501           | 2.89              | <b>R42X3</b>                          | <b>R42X3CF</b>            |
| 42X4.0              | 269                         | 237                           | 669           | 3.75              | <b>R42X4</b>                          | <b>R42X4CF</b>            |
| 50X3.0              | 169                         | 154                           | 421           | 3.48              | <b>R50X3</b>                          | <b>R50X3CF</b>            |
| 60X3.0              | 141                         | 129                           | 351           | 4.22              | <b>R60X3</b>                          | <b>R60X3CF</b>            |
| 75X3.0              | 113                         | 104                           | 281           | 5.32              | <b>R75X3</b>                          | <b>R75X3CF</b>            |
| 90X3.5              | 110                         | 101                           | 273           | 7.47              | <b>R90X3.5</b>                        | <b>R90X3.5CF</b>          |
| 100X4.0             | 113                         | 104                           | 281           | 9.47              | <b>R100X4</b>                         |                           |
| 115X4.0             | 98                          | 91                            | 244           | 10.98             | <b>R115X4</b>                         |                           |
| 140X4.5             | 91                          | 84                            | 226           | 15.04             | <b>R140X4.5</b>                       |                           |
| 165X5.0             | 85                          | 80                            | 213           | 19.73             | <b>R165X5</b>                         |                           |
| 220X6.0             | 77                          | 72                            | 191           | 31.66             | <b>R220X6</b>                         |                           |
| 273X6.0             | 62                          | 58                            | 154           | 39.51             | <b>R273X6</b>                         |                           |

Other sizes on request





## Tubes – Marine and Offshore applications (DNV Rules)

1 DNV Bended pipe including manufacturing and corrosion tolerances

2 DNV Straight pipe including manufacturing and corrosion tolerances

3 Burst pressure (B.P.) calculation including manufacturing tolerance

### Tube E 355N /St.52.4 NBK - Cr(VI)-free plated or phosphated and oiled

| Tube<br>O.D. x W.T. | 1<br>DNV<br>W.P. bar | 2<br>DNV<br>W.P. bar | 3<br>B.P. bar | Weight<br>kg/mtr. | Phosphated<br>and oiled<br>Order code | Cr(VI)-free<br>Order code |
|---------------------|----------------------|----------------------|---------------|-------------------|---------------------------------------|---------------------------|
| 15X1.5              | 259                  | 297                  | 959           | 0.50              |                                       | R15X1.5ST52CF             |
| 15X2.0              | 381                  | 438                  | 1279          | 0.61              |                                       | R15X2ST52CF               |
| 16X2.0              | 355                  | 408                  | 1199          | 0.69              |                                       | R16X2ST52CF               |
| 16X2.5              | 475                  | 547                  | 1499          | 0.83              |                                       | R16X2.5ST52CF             |
| 18X1.5              | 214                  | 244                  | 800           | 0.61              |                                       | R18X1.5ST52CF             |
| 18X2.0              | 313                  | 358                  | 1066          | 0.79              |                                       | R18X2ST52CF               |
| 20X2.0              | 279                  | 319                  | 959           | 0.89              |                                       | R20X2ST52CF               |
| 20X2.5              | 371                  | 426                  | 1199          | 1.08              |                                       | R20X2.5ST52CF             |
| 20X3.0              | 467                  | 537                  | 1439          | 1.25              |                                       | R20X3ST52CF               |
| 22X1.5              | 173                  | 197                  | 654           | 0.76              |                                       | R22X1.5ST52CF             |
| 22X2.0              | 252                  | 288                  | 872           | 0.99              |                                       | R22X2ST52CF               |
| 25X2.5              | 291                  | 333                  | 959           | 1.39              |                                       | R25X2.5ST52CF             |
| 25X3.0              | 365                  | 418                  | 1151          | 1.63              |                                       | R25X3ST52CF               |
| 25X4.0              | 519                  | 599                  | 1535          | 2.07              |                                       | R25X4ST52CF               |
| 28X2.0              | 195                  | 223                  | 685           | 1.28              |                                       | R28X2ST52CF               |
| 30X3.0              | 299                  | 343                  | 959           | 2.00              |                                       | R30X3ST52CF               |
| 30X4.0              | 424                  | 487                  | 1279          | 2.56              |                                       | R30X4ST52CF               |
| 30X5.0              | 555                  | 641                  | 1599          | 3.08              |                                       | R30X5ST52CF               |
| 35X3.0              | 254                  | 290                  | 822           | 2.37              |                                       | R35X3ST52CF               |
| 38X3.0              | 233                  | 266                  | 757           | 2.37              |                                       | R38X3ST52CF               |
| 38X4.0              | 327                  | 375                  | 1010          | 3.35              |                                       | R38X4ST52CF               |
| 38X5.0              | 426                  | 490                  | 1262          | 4.07              |                                       | R38X5ST52CF               |
| 39X7.5              | 673                  | 781                  | 1845          | 8.53              |                                       | R39X7.5ST52CF             |
| 42X3.0              | 209                  | 239                  | 685           | 2.89              |                                       | R42X3ST52CF               |
| 42X4.0              | 294                  | 336                  | 914           | 3.75              |                                       | R42X4ST52CF               |
| 46X8.0              | 601                  | 695                  | 1669          | 7.50              |                                       | R46X8ST52CF               |
| 50X5.0              | 315                  | 361                  | 959           | 5.55              | R50X5ST52                             | R50X5ST52CF               |
| 50X6.0              | 390                  | 448                  | 1151          | 6.50              | R50X6ST52                             | R50X6ST52CF               |
| 56X8.5              | 516                  | 595                  | 1456          | 9.96              | R56X8.5ST52                           |                           |
| 60X5.0              | 259                  | 297                  | 800           | 6.78              |                                       | R60X5ST52CF               |
| 60X6.0              | 319                  | 366                  | 959           | 7.97              | R60X6ST52                             | R60X6ST52CF               |
| 65X8.0              | 407                  | 468                  | 1121          | 11.25             |                                       | R65X8ST52CF               |
| 66X8.5              | 429                  | 494                  | 1236          | 12.05             | R66X8.5ST52                           |                           |
| 73X7.0              | 309                  | 353                  | 920           | 11.22             | R73X7ST52                             | R73X7ST52CF               |
| 75X5.0              | 205                  | 234                  | 640           | 8.63              | R75X5ST52                             | R75X5ST52CF               |
| 80X10               | 418                  | 481                  | 1199          | 17.21             | R80X10ST52                            |                           |
| 90X5.0              | 169                  | 193                  | 533           | 10.48             | R90X5ST52                             | R90X5ST52CF               |
| 90X9.0              | 326                  | 374                  | 959           | 17.98             | R90X9ST52                             | R90X9ST52CF               |
| 97X12               | 416                  | 478                  | 1187          | 25.15             | R97X12ST52                            |                           |
| 115X15              | 444                  | 511                  | 1251          | 36.95             | R115X15ST52                           |                           |
| 130X15              | 388                  | 445                  | 1107          | 42.54             | R130X15ST52                           |                           |
| 150X15              | 332                  | 380                  | 959           | 49.94             | R150X15ST52                           |                           |
| 190X20              | 353                  | 405                  | 1010          | 83.84             | R190X20ST52                           |                           |
| 250X25              | 335                  | 384                  | 959           | 138.72            | R250X25ST52                           |                           |

Other sizes on request

## Tubes – Landbased and industrial applications (DIN Rules)

- 1 DIN 2413 I static pressure (W.P.) capability for straight pipe including manufacturing tolerance  
 2 DIN 2413 III dynamic pressure (W.P.) capability for straight pipe including manufacturing tolerance  
 3 Burst pressure (B.P.) calculation including manufacturing tolerance

### Tube E 355N /St.52.4 NBK - Cr(VI)-free plated or phosphated and oiled

| Tube<br>O.D. x W.T. | 1<br>DIN 2413 I<br>W.P. bar | 2<br>DIN 2413 III<br>W.P. bar | 3<br>B.P. bar | Weight<br>kg/mtr. | Phosphated<br>and oiled<br>Order code | Cr(VI)-free<br>Order code |
|---------------------|-----------------------------|-------------------------------|---------------|-------------------|---------------------------------------|---------------------------|
| 15X1.5              | 426                         | 292                           | 959           | 0.50              |                                       | R15X1.5ST52CF             |
| 15X2.0              | 568                         | 379                           | 1279          | 0.61              |                                       | R15X2ST52CF               |
| 16X2.0              | 533                         | 357                           | 1199          | 0.69              |                                       | R16X2ST52CF               |
| 16X2.5              | 666                         | 436                           | 1499          | 0.83              |                                       | R16X2.5ST52CF             |
| 18X1.5              | 355                         | 247                           | 800           | 0.61              |                                       | R18X1.5ST52CF             |
| 18X2.0              | 473                         | 321                           | 1066          | 0.79              |                                       | R18X2ST52CF               |
| 20X2.0              | 426                         | 292                           | 959           | 0.89              |                                       | R20X2ST52CF               |
| 20X2.5              | 533                         | 357                           | 1199          | 1.08              |                                       | R20X2.5ST52CF             |
| 20X3.0              | 639                         | 420                           | 1439          | 1.25              |                                       | R20X3ST52CF               |
| 22X1.5              | 290                         | 204                           | 654           | 0.76              |                                       | R22X1.5ST52CF             |
| 22X2.0              | 387                         | 267                           | 872           | 0.99              |                                       | R22X2ST52CF               |
| 25X2.5              | 426                         | 292                           | 959           | 1.39              |                                       | R25X2.5ST52CF             |
| 25X3.0              | 511                         | 344                           | 1151          | 1.63              |                                       | R25X3ST52CF               |
| 25X4.0              | 682                         | 445                           | 1535          | 2.07              |                                       | R25X4ST52CF               |
| 28X2.0              | 304                         | 213                           | 685           | 1.28              |                                       | R28X2ST52CF               |
| 30X3.0              | 426                         | 292                           | 959           | 2.00              |                                       | R30X3ST52CF               |
| 30X4.0              | 568                         | 379                           | 1279          | 2.56              |                                       | R30X4ST52CF               |
| 30X5.0              | 710                         | 461                           | 1599          | 3.08              |                                       | R30X5ST52CF               |
| 35X3.0              | 365                         | 253                           | 822           | 2.37              |                                       | R35X3ST52CF               |
| 38X3.0              | 336                         | 234                           | 757           | 2.37              |                                       | R38X3ST52CF               |
| 38X4.0              | 448                         | 306                           | 1010          | 3.35              |                                       | R38X4ST52CF               |
| 38X5.0              | 561                         | 374                           | 1262          | 4.07              |                                       | R38X5ST52CF               |
| 39X7.5              | 819                         | 521                           | 1845          | 8.53              |                                       | R39X7.5ST52CF             |
| 42X3.0              | 304                         | 213                           | 685           | 2.89              |                                       | R42X3ST52CF               |
| 42X4.0              | 406                         | 279                           | 914           | 3.75              |                                       | R42X4ST52CF               |
| 46X8.0              | 741                         | 478                           | 1669          | 7.50              |                                       | R46X8ST52CF               |
| 50X5.0              | 426                         | 292                           | 959           | 5.55              | R50X5ST52                             | R50X5ST52CF               |
| 50X6.0              | 511                         | 344                           | 1151          | 6.50              | R50X6ST52                             | R50X6ST52CF               |
| 56X8.5              | 647                         | 425                           | 1456          | 9.96              | R56X8.5ST52                           |                           |
| 60X5.0              | 355                         | 247                           | 800           | 6.78              |                                       | R60X5ST52CF               |
| 60X6.0              | 426                         | 292                           | 959           | 7.97              | R60X6ST52                             | R60X6ST52CF               |
| 65X8.0              | 524                         | 352                           | 1121          | 11.25             |                                       | R65X8ST52CF               |
| 66X8.5              | 549                         | 367                           | 1236          | 12.05             | R66X8.5ST52                           |                           |
| 73X7.0              | 408                         | 281                           | 920           | 11.22             | R73X7ST52                             | R73X7ST52CF               |
| 75X5.0              | 284                         | 200                           | 640           | 8.63              | R75X5ST52                             | R75X5ST52CF               |
| 80X10               | 533                         | 357                           | 1199          | 17.21             | R80X10ST52                            |                           |
| 90X5.0              | 237                         | 168                           | 533           | 10.48             | R90X5ST52                             | R90X5ST52CF               |
| 90x9.0              | 426                         | 292                           | 959           | 17.98             | R90X9ST52                             | R90X9ST52CF               |
| 97X12               | 527                         | 354                           | 1187          | 25.15             | R97X12ST52                            |                           |
| 115X15              | 556                         | 371                           | 1251          | 36.95             | R115X15ST52                           |                           |
| 130X15              | 492                         | 332                           | 1107          | 42.54             | R130X15ST52                           |                           |
| 150X15              | 426                         | 292                           | 959           | 49.94             | R150X15ST52                           |                           |
| 190X20              | 448                         | 306                           | 1010          | 83.84             | R190X20ST52                           |                           |
| 250X25              | 426                         | 292                           | 959           | 138.72            | R250X25ST52                           |                           |

Other sizes on request

## Tubes – Marine and Offshore applications (DNV Rules)

1 DNV: Bended pipe including manufacturing and corrosion tolerances

2 Burst pressure (B.P.) calculation including manufacturing tolerance

### Seamless cold drawn Stainless Steel Tube ASTM A269/A213 - AISI 316L

| Tube<br>O.D. x W.T. | 1<br>DNV<br>W.P. bar | 2<br>B.P. bar | Weight<br>kg/mtr. | AISI 316L<br>Order code |
|---------------------|----------------------|---------------|-------------------|-------------------------|
| 06X1                | 493                  | 1590          | 0.13              | <b>R06X1-316</b>        |
| 08X1                | 357                  | 1193          | 0.18              | <b>R08X1-316</b>        |
| 10X1                | 298                  | 954           | 0.23              | <b>R10X1-316</b>        |
| 10X1.5              | 467                  | 1431          | 0.32              | <b>R10X1.5-316</b>      |
| 12X1                | 244                  | 795           | 0.28              | <b>R12X1-316</b>        |
| 12X1.5              | 380                  | 1193          | 0.39              | <b>R12X1.5-316</b>      |
| 12X2                | 526                  | 1590          | 0.50              | <b>R12X2-316</b>        |
| 15X1.5              | 298                  | 954           | 0.51              | <b>R15X1.5-316</b>      |
| 16X2                | 380                  | 1193          | 0.70              | <b>R16X2-316</b>        |
| 16X2.5              | 489                  | 1491          | 0.85              | <b>R16X2.5-316</b>      |
| 18X1.5              | 244                  | 795           | 0.62              | <b>R18X1.5-316</b>      |
| 18X2                | 334                  | 1060          | 0.80              | <b>R18X2-316</b>        |
| 20X2                | 298                  | 954           | 0.90              | <b>R20X2-316</b>        |
| 20X2.5              | 380                  | 1193          | 1.10              | <b>R20X2.5-316</b>      |
| 20X3                | 467                  | 1431          | 1.28              | <b>R20X3-316</b>        |
| 22X2                | 268                  | 867           | 1.00              | <b>R22X2-316</b>        |
| 25X2                | 234                  | 763           | 1.13              | <b>R25X2-316</b>        |
| 25X2.5              | 298                  | 954           | 1.41              | <b>R25X2.5-316</b>      |
| 25X3                | 363                  | 1145          | 1.65              | <b>R25X3-316</b>        |
| 28X2                | 207                  | 681           | 1.30              | <b>R28X2-316</b>        |
| 30X2.5              | 244                  | 795           | 1.70              | <b>R30X2.5-316</b>      |
| 30X3                | 298                  | 954           | 2.03              | <b>R30X3-316</b>        |
| 30X4                | 409                  | 1272          | 2.60              | <b>R30X4-316</b>        |
| 35X2                | 164                  | 545           | 1.65              | <b>R35X2-316</b>        |
| 35X3                | 252                  | 818           | 2.40              | <b>R35X3-316</b>        |
| 38X3                | 231                  | 753           | 2.63              | <b>R38X3-316</b>        |
| 38X4                | 315                  | 1004          | 3.41              | <b>R38X4-316</b>        |
| 38X5                | 403                  | 1255          | 4.12              | <b>R38X5-316</b>        |
| 38X6                | 495                  | 1506          | 4.81              | <b>R38X6-316</b>        |
| 42X2                | 136                  | 454           | 1.97              | <b>R42X2-316</b>        |
| 42X3                | 207                  | 681           | 2.93              | <b>R42X3-316</b>        |
| 50X3                | 173                  | 572           | 3.53              | <b>R50X3-316</b>        |
| 50X5                | 298                  | 954           | 5.63              | <b>R50X5-316</b>        |
| 50X6                | 363                  | 1145          | 6.61              | <b>R50X6-316</b>        |
| 60X3                | 143                  | 477           | 4.28              | <b>R60X3-316</b>        |
| 60X5                | 244                  | 795           | 6.89              | <b>R60X5-316</b>        |
| 66X8.5              | 393                  | 1229          | 12.24             | <b>R66X8.5-316</b>      |
| 73X7                | 284                  | 915           | 11.57             | <b>R73X7-316</b>        |
| 75X3                | 113                  | 382           | 5.41              | <b>R75X3-316</b>        |
| 75X5                | 193                  | 636           | 8.76              | <b>R75X5-316</b>        |
| 80X10               | 380                  | 1193          | 17.53             | <b>R80X10-316</b>       |
| 97X12               | 376                  | 1180          | 25.54             | <b>R97X12X5000-316</b>  |

Other sizes on request

## Pipes and tubes

### Tubes - Landbased and industrial applications (DIN Rules)

1 DIN 2413 I static pressure (W.P.) capability for straight pipe including manufacturing tolerance

2 Burst pressure (B.P.) calculation including manufacturing tolerance

#### Seamless cold drawn Stainless Steel Tube ASTM A269/A213 - AISI 316L

| Tube<br>O.D. x W.T. | 1<br>DIN 2413 I<br>W.P. bar | 2<br>B.P. bar | Weight<br>kg/mtr. | AISI 316L<br>Order code |
|---------------------|-----------------------------|---------------|-------------------|-------------------------|
| 06X1                | 490                         | 1590          | 0.13              | <b>R06X1-316</b>        |
| 08X1                | 368                         | 1193          | 0.18              | <b>R08X1-316</b>        |
| 10X1                | 294                         | 954           | 0.23              | <b>R10X1-316</b>        |
| 10X1.5              | 441                         | 1431          | 0.32              | <b>R10X1.5-316</b>      |
| 12X1                | 245                         | 795           | 0.28              | <b>R12X1-316</b>        |
| 12X1.5              | 368                         | 1193          | 0.39              | <b>R12X1.5-316</b>      |
| 12X2                | 490                         | 1590          | 0.50              | <b>R12X2-316</b>        |
| 15X1.5              | 294                         | 954           | 0.51              | <b>R15X1.5-316</b>      |
| 16X2                | 368                         | 1193          | 0.70              | <b>R16X2-316</b>        |
| 16X2.5              | 459                         | 1491          | 0.85              | <b>R16X2.5-316</b>      |
| 18X1.5              | 245                         | 795           | 0.62              | <b>R18X1.5-316</b>      |
| 18X2                | 327                         | 1060          | 0.80              | <b>R18X2-316</b>        |
| 20X2                | 294                         | 954           | 0.90              | <b>R20X2-316</b>        |
| 20X2.5              | 368                         | 1193          | 1.10              | <b>R20X2.5-316</b>      |
| 20X3                | 441                         | 1431          | 1.28              | <b>R20X3-316</b>        |
| 22X2                | 267                         | 867           | 1.00              | <b>R22X2-316</b>        |
| 25X2                | 235                         | 763           | 1.13              | <b>R25X2-316</b>        |
| 25X2.5              | 294                         | 954           | 1.41              | <b>R25X2.5-316</b>      |
| 25X3                | 353                         | 1145          | 1.65              | <b>R25X3-316</b>        |
| 28X2                | 210                         | 681           | 1.30              | <b>R28X2-316</b>        |
| 30X2.5              | 245                         | 795           | 1.70              | <b>R30X2.5-316</b>      |
| 30X3                | 294                         | 954           | 2.03              | <b>R30X3-316</b>        |
| 30X4                | 392                         | 1272          | 2.60              | <b>R30X4-316</b>        |
| 35X2                | 168                         | 545           | 1.65              | <b>R35X2-316</b>        |
| 35X3                | 252                         | 818           | 2.40              | <b>R35X3-316</b>        |
| 38X3                | 232                         | 753           | 2.63              | <b>R38X3-316</b>        |
| 38X4                | 309                         | 1004          | 3.41              | <b>R38X4-316</b>        |
| 38X5                | 387                         | 1255          | 4.12              | <b>R38X5-316</b>        |
| 38X6                | 464                         | 1506          | 4.81              | <b>R38X6-316</b>        |
| 42X2                | 140                         | 454           | 1.97              | <b>R42X2-316</b>        |
| 42X3                | 210                         | 681           | 2.93              | <b>R42X3-316</b>        |
| 50X3                | 176                         | 572           | 3.53              | <b>R50X3-316</b>        |
| 50X5                | 294                         | 954           | 5.63              | <b>R50X5-316</b>        |
| 50X6                | 353                         | 1145          | 6.61              | <b>R50X6-316</b>        |
| 60X3                | 147                         | 477           | 4.28              | <b>R60X3-316</b>        |
| 60X5                | 245                         | 795           | 6.89              | <b>R60X5-316</b>        |
| 66X8.5              | 379                         | 1229          | 12.24             | <b>R66X8.5-316</b>      |
| 73X7                | 282                         | 915           | 11.57             | <b>R73X7-316</b>        |
| 75X3                | 118                         | 382           | 5.41              | <b>R75X3-316</b>        |
| 75X5                | 196                         | 636           | 8.76              | <b>R75X5-316</b>        |
| 80X10               | 368                         | 1193          | 17.53             | <b>R80X10-316</b>       |
| 97X12               | 364                         | 1180          | 25.54             | <b>R97X12X5000-316</b>  |

Other sizes on request



## Pipe according to ANSI B36.19 ASTM - A - 312 - TP - 316L

Pressure table acc. to DNV Rules for Classification of Ships Newbuilding and Mobile Offshore Units Drilling Plants.

1 ANSI B313 pipe including manufacturing tolerance, bending and corrosion considered

2 Burst pressure (B.P.) including manufacturing tolerance

| Nom. Pipe Size<br>SCH size | Tube/Pipe<br>O.D-x W.T. | 1<br>W.P. bar | 2<br>B.P. bar | Weight<br>kg/mtr. | Order code |
|----------------------------|-------------------------|---------------|---------------|-------------------|------------|
| 1/2" SCH 10                | 21.34x2.11              | 249           | 917           | 1.02              | on request |
| 1/2" SCH 40                | 21.34x2.77              | 336           | 1203          | 1.29              | on request |
| 1/2" SCH 80                | 21.34x3.73              | 471           | 1620          | 1.65              | on request |
| 1/2" SCH 160               | 21.34x4.78              | 632           | 2076          | 1.98              | on request |
| 1/2" SCH xxs               | 21.34x7.47              | 1124          | 3245          | 2.55              | on request |
| 3/4" SCH 10                | 26.67x2.11              | 196           | 733           | 1.30              | on request |
| 3/4" SCH 40                | 26.67x2.81              | 267           | 977           | 1.71              | on request |
| 3/4" SCH 80                | 26.67x3.91              | 385           | 1359          | 2.33              | on request |
| 3/4" SCH 160               | 26.67x5.56              | 579           | 1933          | 2.94              | on request |
| 3/4" SCH xxs               | 26.67x7.82              | 886           | 2718          | 3.64              | on request |
| 1" SCH 10                  | 33.40x2.77              | 206           | 769           | 2.13              | on request |
| 1" SCH 40                  | 33.40x3.38              | 255           | 938           | 2.54              | on request |
| 1" SCH 80                  | 33.40x4.55              | 354           | 1263          | 3.29              | on request |
| 1" SCH 160                 | 33.40x6.35              | 805           | 1762          | 4.30              | on request |
| 1" SCH xxs                 | 33.40x9.09              | 805           | 2523          | 5.45              | on request |
| 1 1/4" SCH 10              | 42.16x2.77              | 161           | 609           | 2.73              | on request |
| 1 1/4" SCH 40              | 42.16x3.56              | 210           | 783           | 3.44              | on request |
| 1 1/4" SCH 80              | 42.16x4.85              | 294           | 1066          | 4.53              | on request |
| 1 1/4" SCH 160             | 42.16x6.35              | 397           | 1396          | 5.69              | on request |
| 1 1/4" SCH xxs             | 42.16x9.70              | 653           | 2133          | 7.76              | on request |
| 1 1/2" SCH 10              | 48.26x2.77              | 139           | 532           | 3.16              | on request |
| 1 1/2" SCH 40              | 48.26x3.68              | 188           | 707           | 4.11              | on request |
| 1 1/2" SCH 80              | 48.26x5.08              | 266           | 976           | 5.49              | on request |
| 1 1/2" SCH 160             | 48.26x7.14              | 389           | 1371          | 7.35              | on request |
| 1 1/2" SCH xxs             | 48.26x10.16             | 586           | 1952          | 9.55              | on request |
| 2" SCH 10                  | 60.30x2.77              | 111           | 426           | 3.99              | on request |
| 2" SCH 40                  | 60.30x3.91              | 159           | 601           | 5.52              | on request |
| 2" SCH 80                  | 60.30x5.54              | 230           | 852           | 7.60              | on request |
| 2" SCH 160                 | 60.30x8.74              | 380           | 1344          | 11.28             | on request |
| 2" SCH xxs                 | 60.30x11.07             | 498           | 1702          | 13.44             | on request |
| 2 1/2" SCH 5               | 73.00x2.11              | 69            | 268           | 3.76              | on request |
| 2 1/2" SCH 10              | 73.00x3.05              | 100           | 387           | 5.37              | on request |
| 2 1/2" SCH 40              | 73.00x5.16              | 174           | 655           | 8.80              | on request |
| 2 1/2" SCH 80              | 73.00x7.01              | 241           | 890           | 11.64             | on request |
| 2 1/2" SCH 160             | 73.00x9.53              | 338           | 1210          | 15.15             | on request |
| 2 1/2" SCH xxs             | 73.00x14.02             | 526           | 1780          | 20.50             | on request |
| 3" SCH 5                   | 88.90x2.11              | 56            | 220           | 4.59              | on request |
| 3" SCH 10                  | 88.90x3.05              | 82            | 318           | 6.45              | on request |
| 3" SCH 40                  | 88.90x5.49              | 151           | 572           | 11.64             | on request |
| 3" SCH 80                  | 88.90x7.67              | 215           | 800           | 15.51             | on request |
| 3" SCH 160                 | 88.90x11.13             | 322           | 1161          | 21.67             | on request |
| 3" SCH xxs                 | 88.90x15.24             | 460           | 1589          | 27.68             | on request |
| 4" SCH 5                   | 114.30x2.11             | 43            | 171           | 5.93              | on request |
| 4" SCH 10                  | 114.30x3.05             | 63            | 247           | 8.50              | on request |
| 4" SCH 40                  | 114.30x6.07             | 129           | 492           | 16.32             | on request |
| 4" SCH 80                  | 114.30x8.56             | 185           | 694           | 22.67             | on request |
| 4" SCH 160                 | 114.30x13.49            | 302           | 1094          | 34.05             | on request |
| 4" SCH xxs                 | 114.30x17.12            | 394           | 1388          | 41.03             | on request |
| 5" SCH 10                  | 141.30x3.40             | 57            | 233           | 41.03             | on request |
| 5" SCH 40                  | 141.30x6.55             | 112           | 430           | 41.03             | on request |
| 5" SCH 80                  | 141.30x9.53             | 165           | 625           | 41.03             | on request |
| 5" SCH 160                 | 141.30x15.88            | 286           | 1042          | 41.03             | on request |
| 5" SCH xxs                 | 141.30x19.05            | 350           | 1250          | 41.03             | on request |
| 6" SCH 40                  | 168.30x7.11             | 101           | 392           | 28.69             | on request |
| 6" SCH 160                 | 168.30x18.26            | 275           | 1006          | 67.56             | on request |
| 6" SCH xxs                 | 168.30x21.95            | 337           | 1209          | 79.21             | on request |
| 8" SCH 40                  | 219.10x8.18             | 89            | 346           | 43.20             | on request |
| 8" SCH 160                 | 219.10x23.01            | 266           | 974           | 111.30            | on request |
| 8" SCH xxs                 | 219.10x22.00            | 253           | 931           | 106.88            | on request |
| 10" SCH xxs                | 273.00x25.40            | 233           | 862           | 101.90            | on request |

Other sizes on request

Temperature conversion table

Celsius to Fahrenheit

| °C  | °F  |
|-----|-----|
| 150 | 302 |
| 145 | 293 |
| 140 | 284 |
| 135 | 275 |
| 130 | 266 |
| 125 | 257 |
| 120 | 248 |
| 115 | 239 |
| 110 | 230 |
| 105 | 221 |
| 100 | 212 |
| 95  | 203 |
| 90  | 194 |
| 85  | 185 |
| 80  | 176 |
| 75  | 167 |
| 70  | 158 |
| 65  | 149 |
| 60  | 140 |
| 55  | 131 |
| 50  | 122 |
| 45  | 113 |
| 40  | 104 |
| 35  | 95  |
| 30  | 86  |
| 25  | 77  |
| 20  | 68  |
| 15  | 59  |
| 10  | 50  |
| 5   | 41  |
| 0   | 32  |
| -5  | 23  |
| -10 | 14  |
| -15 | 5   |
| -20 | -4  |
| -25 | -13 |
| -30 | -22 |
| -35 | -31 |
| -40 | -40 |
| -45 | -49 |
| -50 | -58 |

Fahrenheit to Celsius

| °F  | °C  |
|-----|-----|
| 340 | 171 |
| 330 | 166 |
| 320 | 160 |
| 310 | 154 |
| 300 | 149 |
| 290 | 143 |
| 280 | 138 |
| 270 | 132 |
| 260 | 127 |
| 250 | 121 |
| 240 | 116 |
| 230 | 110 |
| 220 | 104 |
| 210 | 99  |
| 200 | 93  |
| 190 | 88  |
| 180 | 82  |
| 170 | 77  |
| 160 | 71  |
| 150 | 66  |
| 140 | 60  |
| 130 | 54  |
| 120 | 49  |
| 110 | 43  |
| 100 | 38  |
| 90  | 32  |
| 80  | 27  |
| 70  | 21  |
| 60  | 16  |
| 50  | 10  |
| 40  | 4   |
| 30  | -1  |
| 20  | -7  |
| 10  | -12 |
| 0   | -18 |
| -10 | -23 |
| -20 | -29 |
| -30 | -34 |
| -40 | -40 |
| -50 | -46 |
| -60 | -51 |

Pressure conversion table

bar to psi

| bar  | psi   |
|------|-------|
| 1000 | 14505 |
| 800  | 11604 |
| 600  | 8703  |
| 500  | 7253  |
| 400  | 5802  |
| 250  | 3626  |
| 160  | 2321  |
| 100  | 1451  |
| 60   | 870   |
| 40   | 580   |
| 35   | 508   |
| 25   | 363   |
| 16   | 232   |
| 10   | 145   |
| 6    | 87    |
| 4    | 58    |
| 2.5  | 36    |
| 1.6  | 23    |
| 1    | 15    |

psi to bar

| psi   | bar  |
|-------|------|
| 10000 | 689  |
| 9000  | 620  |
| 7000  | 483  |
| 6000  | 414  |
| 4000  | 276  |
| 3000  | 207  |
| 2500  | 172  |
| 1000  | 69   |
| 900   | 62   |
| 600   | 41   |
| 500   | 34   |
| 400   | 28   |
| 250   | 17   |
| 150   | 10.3 |
| 100   | 6.9  |
| 90    | 6.2  |
| 60    | 4.1  |
| 40    | 2.8  |
| 25    | 1.7  |
| 10    | 0.7  |

Examples

Temperature conversion

Initial value: 100  
 °C in °F: 212 °F  
 °F in °C: 37.78 °C

Pressure conversion

Initial value: 35  
 bar in psi: 507.675 psi  
 psi in bar: 2.41296 bar





