

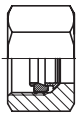

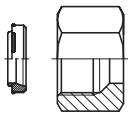

EO[®] Ermeto Originali
Raccordi DIN

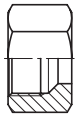

Indice generale

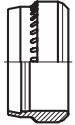
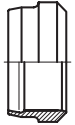
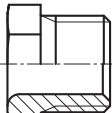
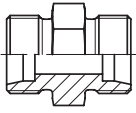
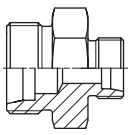
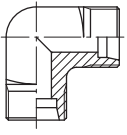
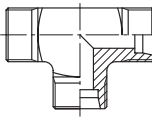
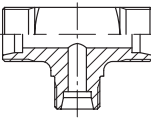
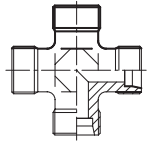
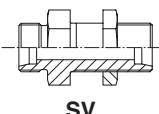
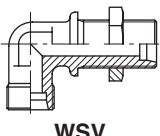
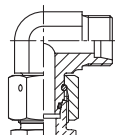
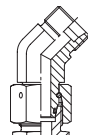
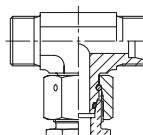
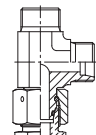
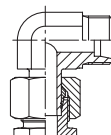
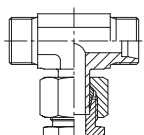
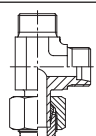
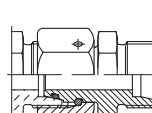
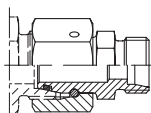
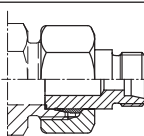
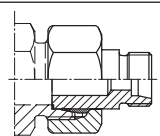
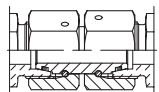
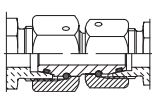
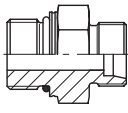
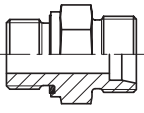
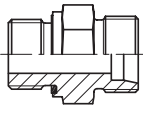
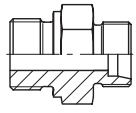
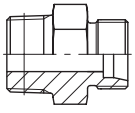
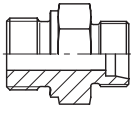
Componenti per raccordi	 <p>FM p. 110</p>	 <p>FORM p. 112</p>	 <p>M p. 114</p>	 <p>D p. 115</p>	 <p>PSR p. 115</p>	 <p>DPR p. 116</p>
	 <p>S p. 117</p>					
Tubo-tubo	 <p>G p. 118</p>	 <p>GR p. 119</p>	 <p>W p. 120</p>	 <p>T p. 119</p>	 <p>TR p. 122</p>	 <p>K p. 124</p>
	 <p>SV p. 125</p>	 <p>WSV p. 126</p>				
Tubo-dado girevole	 <p>EW p. 127</p>	 <p>EV p. 128</p>	 <p>ET p. 129</p>	 <p>EL p. 130</p>	 <p>EVW p. 131</p>	 <p>EVT p. 132</p>
	 <p>EVL p. 133</p>	 <p>DA p. 134</p>	 <p>RED p. 135</p>	 <p>KOR (Acciaio/Ottone) p. 139</p>	 <p>KOR (Acciaio inossidabile) p. 143</p>	
Dado girevole-dado girevole	 <p>GZ p. 145</p>	 <p>GZR S.46</p>				
Terminale maschio diritto	 <p>GEO p. 148</p>	 <p>GE-M-ED p. 149</p>	 <p>GE-R-ED p. 150</p>	 <p>GE-R p. 152</p>	 <p>GE-R(KEG) p. 154</p>	 <p>GE-M p. 155</p>



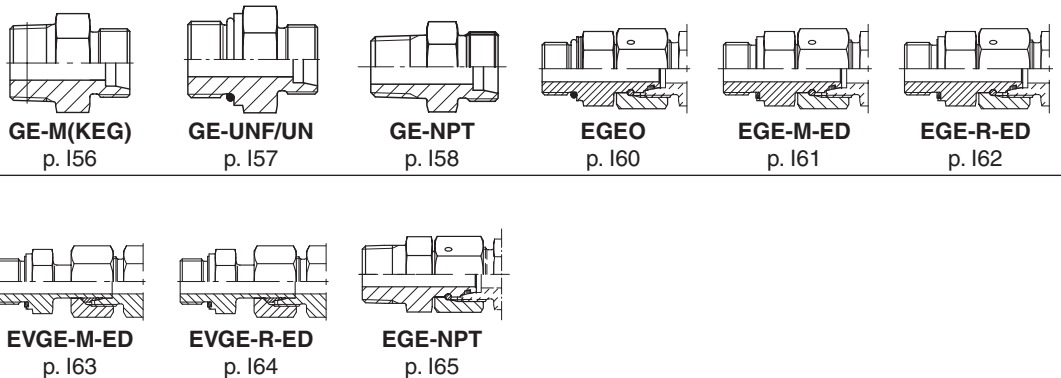
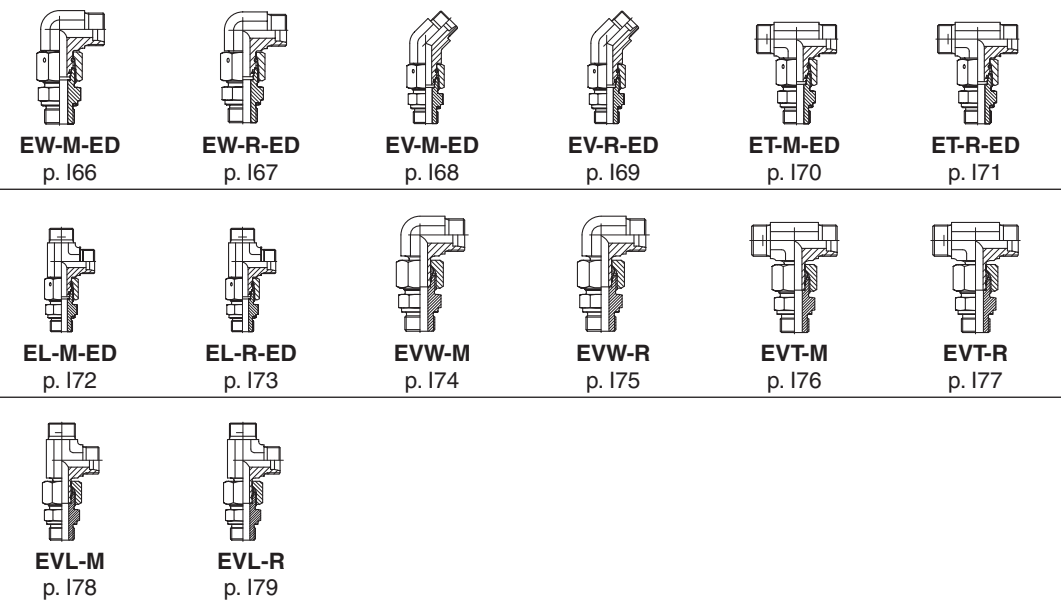
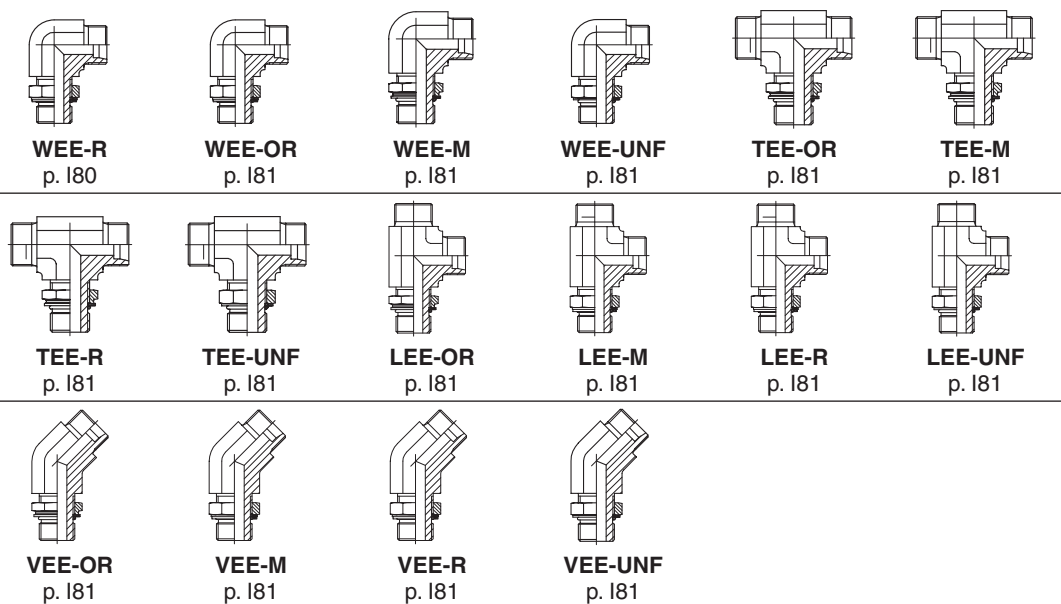



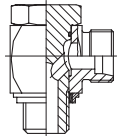
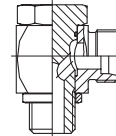
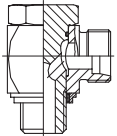
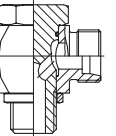
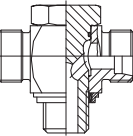
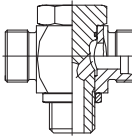
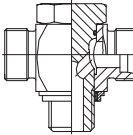
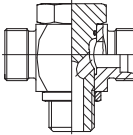
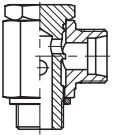
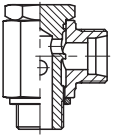
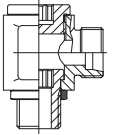
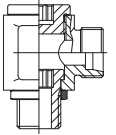
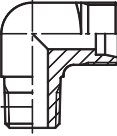
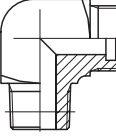
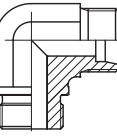
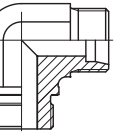
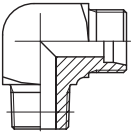
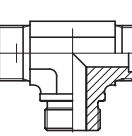
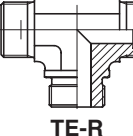
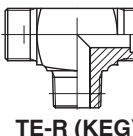
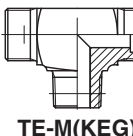
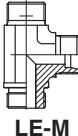
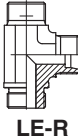
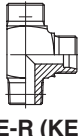
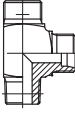
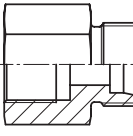
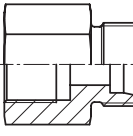
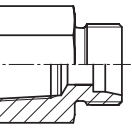
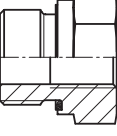
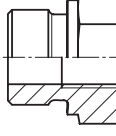
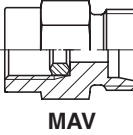
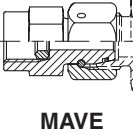

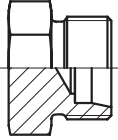
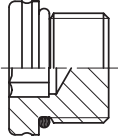
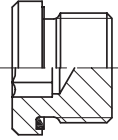
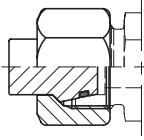
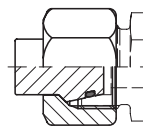
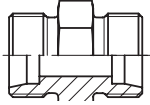
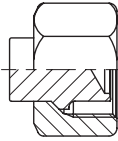

Indice generale

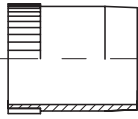
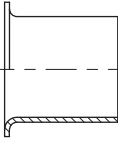
 Terminale
maschio diritto

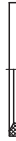
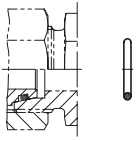
 Dado girevole
orientabile

 Raccordo orientabile
con dado di bloccaggio

Indice generale

Raccordo banjo	 <p>WH-M-KDS p. 182</p>	 <p>WH-M p. 181</p>	 <p>WH-R-KDS p. 184</p>	 <p>WH-R p. 185</p>	 <p>TH-M-KDS p. 186</p>	 <p>TH-M p. 187</p>
	 <p>TH-R-KDS p. 188</p>	 <p>TH-R p. 189</p>	 <p>SWVE-M/KDS p. 190</p>	 <p>SWVE-R/KDS p. 191</p>	 <p>DSVW-M p. 192</p>	 <p>DSVW-R p. 193</p>
Raccordo non orientabili	 <p>WE-NPT p. 194</p>	 <p>WE-M(KEG) p. 195</p>	 <p>WE-M p. 196</p>	 <p>WE-R p. 197</p>	 <p>WE-R(KEG) p. 198</p>	 <p>TE-M p. 199</p>
	 <p>TE-R p. 1100</p>	 <p>TE-R(KEG) p. 1101</p>	 <p>TE-M(KEG) p. 1102</p>	 <p>LE-M p. 1103</p>	 <p>LE-R p. 1104</p>	 <p>LE-R(KEG) p. 1105</p>
	 <p>LE-M(KEG) p. 1106</p>					
Tubo-terminale femmina	 <p>GAI-M p. 1107</p>	 <p>GAI-R p. 1108</p>	 <p>GAI-NPT p. 1109</p>			
Raccordo riduzione	 <p>RI-ED p. 1110</p>	 <p>RI p. 1111</p>				
Adattatori monometro	 <p>MAV p. 1112</p>	 <p>MAVE p. 1113</p>				

Indice generale

Tappi						
	ROV p. 1114	VSTI M-OR p. 1115	VSTI M/R-ED p. 1116	VKA p. 1117	VKAM p. 1118	BUZ p. 1119
						
	BUZM p. 1120					
Componenti						
	GM p. 1121	VH p. 1122	E p. 1123	DOZ p. 1124	ED p. 1125	OR p. 126
						
	DK1 p. 1128	KDS p. 1129	KD p. 1130	DKAZ p. 1131	DKA p. 1132	



Come ordinare



Raccordi DIN

GE-R-ED Terminale maschio diritto

Filettatura maschio BSPP – Guarnizione ED (ISO 1179) / Estremità conica EO 24°

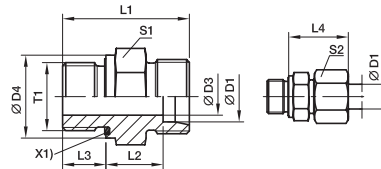

X1) Guarnizione Elastica ED

Serie	D1	T1	D3	D4	L1	L2	L3	L4	S1	S2	Peso g/1 pezzo	Codice di ordinazione*	PN (bar) ¹⁾		
													CF	71	MS
S ⁴⁾	06	G 1/4 A	4	19	32,0	13,0	12	28	19	17	35	GE06SREDOMD	800	630	400
	06	G 1/8 A	4	14	27,5	12,5	8	27	14	17	21	GE06SR1/8EDOMD	500	315	
	06	G 3/8 A	4	22	34,5	15,5	12	30	22	17	52	GE06SR3/8EDOMD	630	630	
	06	G 1/2 A	4	27	39,0	18,0	14	33	27	17	83	GE06SR1/2EDOMD	630	400	
	08	G 1/4 A	5	19	34,0	15,0	12	30	19	19	41	GE08SREDOMD	800	630	400
	08	G 3/8 A	5	22	34,5	15,5	12	30	22	19	57	GE08SR3/8EDOMD	800	630	
	08	G 1/2 A	5	27	39,0	18,0	14	33	27	19	89	GE08SR1/2EDOMD	630	400	
	10	G 3/8 A	7	22	34,5	15,0	12	31	22	22	55	GE10SREDOMD	800	630	400
	10	G 1/4 A	5	19	34,0	14,5	12	31	19	22	42	GE10SR1/4EDOMD	800	630	
	10	G 1/2 A	7	27	39,0	17,5	14	34	27	22	97	GE10SR1/2EDOMD	630	630	
	12	G 3/8 A	8	22	36,5	17,0	12	33	22	24	62	GE12SREDOMD	630	630	400
	12	G 1/4 A	5	19	36,0	16,5	12	33	22	24	61	GE12SR3/8EDOMD	630	630	
	12	G 1/2 A	8	27	39,0	17,5	14	34	27	24	99	GE12SR3/4EDOMD	630	630	
	14	G 1/2 A	10	27	41,0	19,0	14	37	27	27	96	GE14SR3/8EDOMD	630	630	400
	14	G 3/8 A	8	22	38,5	18,5	12	36	24	27	77	GE14SR3/4EDOMD	630	630	
	14	G 3/4 A	10	32	45,0	21,0	16	39	32	27	117	GE14SR3/2EDOMD	630	630	
	16	G 1/2 A	12	27	41,0	18,5	14	37	27	30	100	GE16SREDOMD	800	400	250
	16	G 3/8 A	8	22	38,5	18,0	12	36	27	30	115	GE16SR3/8EDOMD	800	400	
	16	G 3/4 A	12	32	45,0	20,5	16	39	32	30	115	GE16SR3/4EDOMD	800	400	
	20	G 3/4 A	16	32	47,0	20,5	16	42	32	36	142	GE16SR3/2EDOMD	800	400	250
	20	G 1/2 A	12	27	45,0	20,5	14	42	32	36	142	GE20SREDOMD	800	400	
	20	G 1 A	16	40	51,0	22,5	18	44	41	36	265	GE20SR1/2EDOMD	420	400	
	20	G 1 1/4 A	16	50	53,0	22,5	20	44	50	36	404	GE20SR1/4EDOMD	420	400	
	25	G 1 A	20	40	53,0	23,0	18	47	41	46	266	GE25SREDOMD	420	400	250
	25	G 1/2 A	12	27	49,0	23,0	14	47	41	46	228	GE25SR1/2EDOMD	420	400	
	25	G 3/4 A	16	32	51,0	23,0	16	47	41	46	255	GE25SR3/4EDOMD	420	400	
	25	G 1 1/4 A	20	50	55,0	23,0	20	47	50	46	411	GE25SR11/4EDOMD	420	400	
	25	G 1 1/2 A	20	55	60,0	26,0	22	50	55	46	549	GE25SR11/2EDOMD	315	315	
	30	G 1 1/4 A	25	50	57,0	23,5	20	50	50	50	418	GE30SREDOMD	420	400	250
	30	G 1 A	20	40	55,0	23,5	18	50	46	50	344	GE30SR1EDOMD	420	400	
	30	G 1 1/2 A	25	55	62,0	26,5	22	53	55	50	530	GE30SR11/2EDOMD	315	315	
	38	G 1 1/2 A	32	55	64,0	26,0	22	57	55	60	563	GE38SREDOMD	420	315	200
	38	G 1 1/4 A	25	50	62,0	26,0	20	57	55	60	575	GE38SR11/4EDOMD	420	315	

¹⁾ Pressione indicata = Articolo disponibile

⁴⁾ S = Serie pesante

PN (bar) = PN (MPa)

10

Consegna senza dado né anello. Per informazioni sull'ordinazione di raccordi completi o sui materiali di tenuta alternativi vedere pag. 17.

*Aggiungere i suffissi qui di seguito in base al materiale e alla superficie richiesti.

Materiale	Superficie	Materiale di tenuta standard (non occorre suffisso aggiuntivo)
Acciaio, zincato, esente da CromoVI		GE16SREDOMDCF
Acciaio inossidabile		GE16SREDOMD71
Ottone		GE16SREDOMDM
		NBR
		VIT
		NBR

È facile ordinare nel modo corretto!

Fase 1

Selezione del codice di ordinazione

- 1.1 Tutte le dimensioni di raccordi disponibili nel nostro programma sono chiaramente elencate nell'indice all'inizio di questo catalogo.
- 1.2 Aprire il catalogo alla pagina corrispondente contenente le informazioni dettagliate sul prodotto prescelto.
- 1.3 Selezionare le dimensioni di raccordo richieste! Il codice di ordinazione di base è stampato in grassetto sul lato destro della tabella delle dimensioni.

Esempio: **GE16SREDOMD**

Fase 2

Selezione del materiale, della superficie e del materiale di tenuta

Ora aggiungere semplicemente al codice di ordinazione di base il codice corrispondente alla variante di superficie e materiale del prodotto richiesto. Questo codice è contenuto nella tabella riportata nella parte inferiore di ogni pagina.

2.1 Materiale

in base al materiale e alla superficie richiesti. e di tenuta alternativo

Esempio: raccordo in acciaio esente da cromoVI con guarnizione ED in materiale FKM.
GE16SRED+OMD+VIT+CF
= GE16SREDVITOMDCF

Esempio: raccordo in acciaio inossidabile con guarnizione ED in materiale NBR (es. Perbunan)
GE16SREDOMD+NBR+71
= GE16SREDNBRMD71

Fase 3

All'ordinazione dei raccordi completi di dadi e anelli

- 3.1. Anelli taglianti a tenuta metallica PSR/DPR/D: per questi tipi eliminare i suffissi "OMD" o "X".
Esempio: **GE16SREDCF**
- 3.2. Dado a duplice funzione EO-2 con guarnizione in gomma: per questi tipi eliminare i suffissi "OMD" o "X" e aggiungere una "Z" prima del suffisso della serie (LL, L, S)
Esempio: **ordine con dado a duplice funzione EO-2**
GE16(+Z)SREDCF
= GE16ZSREDCF

Perbunan = marchio registrato di Bayer

La variante dell'ordine corrispondente è contenuta nella tabella riportata nella parte inferiore di ogni capitolo DIN.

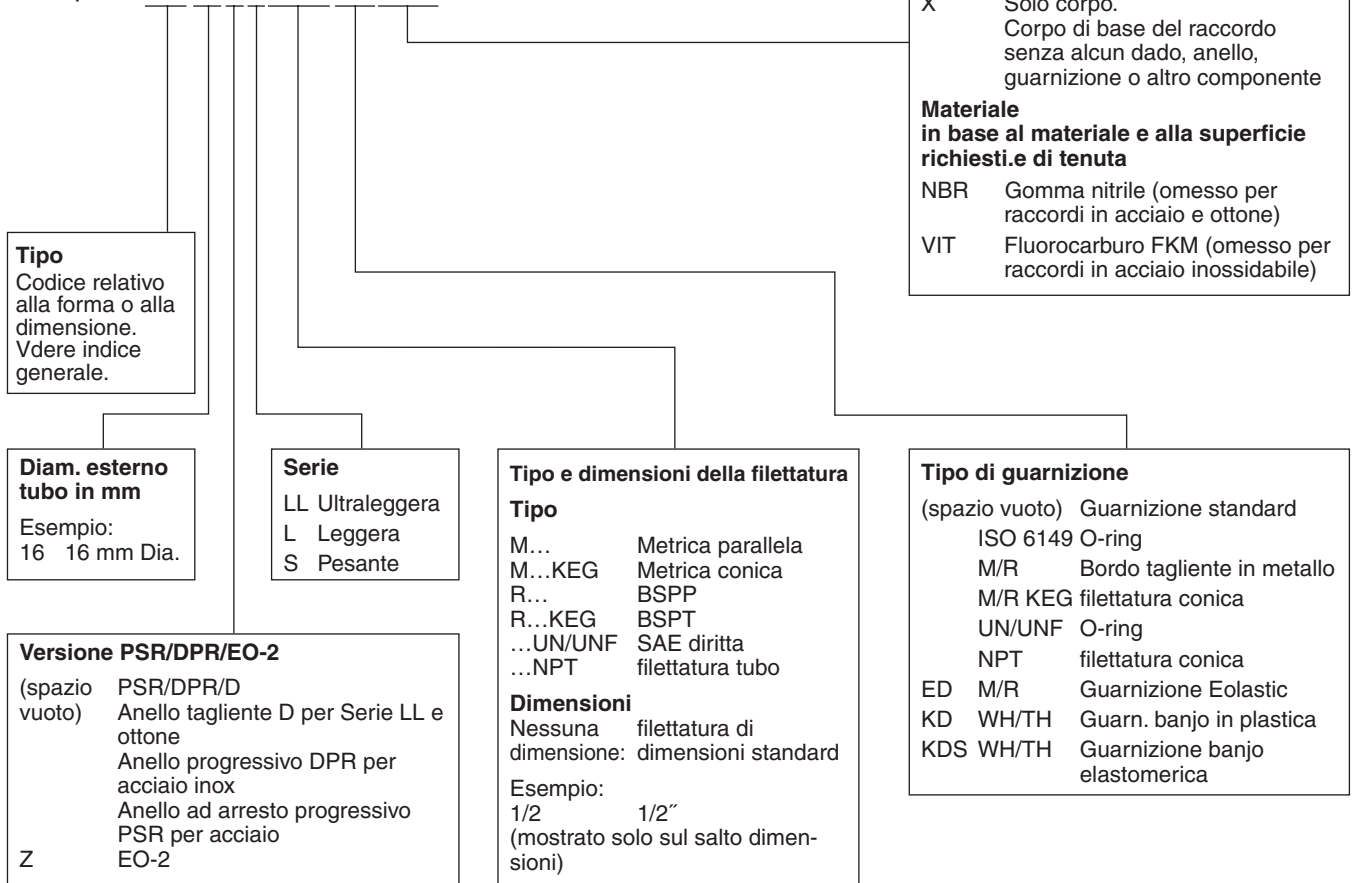

Come ordinare i raccordi EO

 Esempio: **GE16ZSR3/8EDCF**

Esempi			
Codice di ordinazione	Descrizione	Codice di ordinazione	Descrizione
GE20ZSR1/2EDCF	Terminale maschio dritto, EO-2, diam. est. tubo 12 mm, serie pesante, G 1/2 BSPP, guarnizione Eolastic, completo di dado e anello, raccordo in acciaio privo esente da cromoVI, tutte le guarnizioni NBR	EVT08LOMDMS	T di linea con codolo orientabile, diam. est. tubo 8 mm, serie leggera, raccordo in ottone senza dado né anello, codolo premontato con dado e anello
GE12LR71X	Terminale maschio ritto, diam. est. tubo 12 mm, serie leggera, G 3/8 BSPP, guarnizione metallica tipo B, raccordo in acciaio inossidabile, solo corpo	EL38VITOMDCF	T di derivazione con dado girevole orientabile, diam. est. tubo 38 mm, serie pesante, raccordo in acciaio zincato senza dado né anello. Estremità dado girevole con guarnizione FKM
		DOZ04LL	Guarnizione di ricambio per giunti EO-2, diam. est. 4 mm, serie ultraleggera, acciaio con guarnizione in gomma nitrile

Perbunan = marchio registrato di Bayer

Codice per stili/forme dei raccordi

BUZ	Tappo protettivo per coni
BUZM	Tappo protettivo con dado per coni
D	Anello tagliente – Estremità conica EO 24°
DA	Adattatore distanziale – Dado girevole EO 24° DKO/Estremità conica EO 24°
DKA	Anello di tenuta – Per raccordi banjo WH/TH e SWVE
DKAZ	Anello di tenuta – Per banjo DSVW per basse pressioni
DKI	Anello di tenuta per connettori portamanometri
DOZ	Anello di tenuta in gomma EO-2
DPR	Anello progressivo – Estremità conica EO 24°
DSVW-M	Gomito banjo per basse pressioni – Estremità conica EO 24°/Filettatura maschio metrica
DSVW-R	Gomito banjo per basse pressioni – Estremità conica EO 24°/Filettatura maschio BSPP
E	Inserito di rinforzo tubo – Per tubature in plastica
ED	Guarnizione in gomma Eolastic (per filettature metriche e BSPP parallele)
EGE-M-ED	Raccordo con dado girevole – Filettatura maschio metrica – Guarnizione ED (ISO 9974)/Dado girevole EO 24° DKO
EGE-NPT	Raccordo con dado girevole – Filettatura maschio NPT (SAE J476)/Dado girevole EO 24° DKO
EGEO	Raccordo con dado girevole – Filettatura maschio metrica – O-ring (ISO 6149)/Dado girevole EO 24° DKO
EGE-R-ED	Raccordo con dado girevole – Filettatura maschio BSPP – Guarnizione ED (ISO 1179)/Dado girevole EO 24° DKO
EL	T di derivazione con dado girevole/Estremità conica EO 24°/Dado girevole EO 24° DKO
EL-M-ED	T di derivazione orientabile con dado girevole assemblato – Estremità conica EO 24°/Filettatura maschio metrica – Guarnizione ED (ISO 9974)
EL-R-ED	T di derivazione orientabile con dado girevole assemblato – Estremità conica EO 24°/Filettatura maschio BSPP – Guarnizione ED (ISO 1179)
ET	T di linea con dado girevole – Estremità conica EO 24°/Dado girevole EO 24° DKO
ET-M-ED	T di linea orientabile con dado girevole assemblato – Estremità conica EO 24°/Filettatura maschio metrica – Guarnizione ED (ISO 9974)
ET-R-ED	T di linea orientabile con dado girevole assemblato – Estremità conica EO 24°/Filettatura maschio BSPP – Guarnizione ED (ISO 1179)
EV	Gomito a 45° con dado girevole – Estremità conica EO 24°/Dado girevole EO 24° DKO
EVGE-M-ED	Raccordo per codolo – Filettatura maschio metrica – ED (ISO 9974)/Codolo EO orientabile
EVGE-R-ED	Raccordo per codolo – Filettatura maschio BSPP – Guarnizione ED (ISO 1179)/Codolo EO orientabile
EVL	T di derivazione per codolo – Estremità conica EO 24°/Codolo EO orientabile
EVL-M	T di derivazione codolo orientabile assemblato – Estremità conica EO 24°/Filettatura maschio metrica – bordo di tenuta metallico (ISO 9974)
EVL-R	T di derivazione codolo orientabile assemblato – Estremità conica EO 24°/Filettatura maschio BSPP – bordo di tenuta metallico (ISO 1179)
EV-M-ED	Gomito 45° orientabile con dado girevole assemblato – Estremità conica EO 24°/Filettatura maschio metrica – Guarnizione ED (ISO 9974)
EV-R-ED	Gomito 45° orientabile con dado girevole assemblato – Estremità conica EO 24°/Filettatura maschio BSPP – Guarnizione ED (ISO 1179)
EVT	T di linea per codolo – Estremità conica EO 24°/Codolo EO orientabile
EVT-M	T di linea codolo orientabile assemblato – Estremità conica EO 24°/Filettatura maschio metrica – bordo di tenuta metallico (ISO 9974)
EVT-R	T di linea codolo orientabile assemblato – Estremità conica EO 24°/Filettatura maschio BSPP – bordo di tenuta metallico (ISO 1179)
EVW	Gomito per codolo – Estremità conica EO 24°/Codolo EO orientabile
EVW-M	Gomito codolo orientabile assemblato – Estremità conica EO 24°/Filettatura maschio metrica – bordo di tenuta metallico (ISO 9974)
EVW-R	Gomito codolo orientabile assemblato – Estremità conica EO 24°/Filettatura maschio BSPP – bordo di tenuta metallico (ISO 9974)
EW	Gomito con dado girevole – Estremità conica EO 24°/Dado girevole EO 24° DKO
EW-M-ED	Gomito orientabile con dado girevole assemblato – Estremità conica EO 24°/Filettatura maschio metrica – Guarnizione ED (ISO 9974)
EW-R-ED	Gomito orientabile con dado girevole assemblato – Estremità conica EO 24°/Filettatura maschio BSPP – Guarnizione ED (ISO 1179)
FM	Dado a duplice funzione EO2
FORM	Dado a duplice funzione EO2-FORM
G	Raccordo intermedio – Estremità conica EO 24°
GAI-M	Terminale diritto femmina – Filettatura metrica (ISO 9974-1)/Estremità conica EO 24°
GAI-NPT	Terminale diritto femmina – Filettatura femmina NPT (SAE 476)/Estremità conica EO 24°
GAI-R	Terminale diritto femmina – Filettatura femmina BSPP (ISO 1179-1)/Estremità conica EO 24°
GE-M	Terminale maschio diritto – Filettatura maschio metrica – bordo di tenuta metallico (ISO 9974)/Estremità conica EO 24°
GE-M (KEG)	Terminale maschio diritto – Filettatura maschio metrica conica corta (DIN 3852-1, tipo C)/Estremità conica EO 24°
GE-M-ED	Terminale maschio diritto – Filettatura maschio metrica – ED (ISO 9974)/Estremità conica EO 24°
GE-NPT	Terminale maschio diritto – Filettatura maschio NPT (SAE J476)/Estremità conica EO 24°
GEO	Terminale maschio diritto – Filettatura maschio metrica – O-ring (ISO 6149)/Estremità conica EO 24°
GE-R	Terminale maschio diritto – Filettatura maschio BSPP – bordo di tenuta metallico ED (ISO 1179)/Estremità conica EO 24°
GE-R (KEG)	Terminale maschio diritto – Filettatura maschio BSPP conica corta (DIN 3852-2, tipo C)/Estremità conica EO 24°
GE-R-ED	Terminale maschio diritto – Filettatura maschio BSPP – Guarnizione ED (ISO 1179)/Estremità conica EO 24°
GE-UNF/UN	Terminale maschio diritto – Filettatura maschio UNF/UN – O-ring (ISO 11926)/Estremità conica EO 24°
GM	Dado di bloccaggio per raccordi passaparatia – Per raccordi passaparatia SV e WSV
GR	Raccordo riduzione diritto – Estremità conica EO 24°

Codice per stili/forme dei raccordi

GZ	Raccordo intermedio con dado girevole – Dado girevole EO 24° DKO
GZR	Raccordo riduzione con dado girevole – Dado girevole EO 24° DKO
K	Raccordo intermedio a croce – Estremità conica EO 24°
KD	Anello di tenuta in gomma per raccordi banjo WH/TH in acciaio inossidabile – Per connessioni con lamatura ampia
KDS	Anello di tenuta in gomma per raccordi banjo WH/TH in acciaio – Per connessioni con lamatura ampia e ridotta
KOR	Raccordo riduzione tubo – Acciaio e ottone – Codolo EO orientabile/Estremità conica EO 24°
LEE	Gomito orientabile con dado di bloccaggio – EO 24°/filettatura orientabile
LE-M	T di derivazione con terminale maschio – Estremità conica EO 24°/Filettatura maschio metrica – bordo di tenuta metallico (ISO 9974)
LE-M (KEG)	T di derivazione con terminale maschio – Estremità conica EO 24°/Filettatura maschio metrica conica corta (DIN 3852-1, Configurazione C)
LE-R	T di derivazione con terminale maschio – Estremità conica EO 24°/Filettatura maschio BSPP – bordo di tenuta metallico (ISO 1179)
LE-R (KEG)	T di derivazione con terminale maschio – Estremità conica EO 24°/Filettatura maschio BSP conica corta (DIN 3852-2, tipo C)
M	Dado – Estremità conica EO 24°
MAV	Connettore per manometro – Filettatura femmina BSPP/Estremità conica EO 24°
MAVE	Connettore per manometro con dado girevole – Filettatura femmina BSPP/Dado girevole EO 24° DKO
OR	O-ring
PSR	Anello ad arresto progressivo – Estremità conica EO 24°
RED	Raccordo riduzione tubo – Dado girevole EO 24° DKO/Estremità conica EO 24°
RI	Raccordo riduzione/espansione filettatura – Filettatura maschio BSPP – bordo di tenuta metallico (ISO 1179)/Filettatura femmina BSPP (ISO 1179-1)
RI-ED	Raccordo riduzione/espansione filettatura – Filettatura maschio BSPP – Guarnizione ED (ISO 1179)/Filettatura femmina BSPP (ISO 1179-1)
ROV	Tappo protettivo per estremità tubi – Estremità conica EO 24°
S	Ghiera passante di bloccaggio – per fori filettatura in conformità a DIN 3854
SV	Raccordo intermedio passaparatia – Estremità conica EO 24°
SWVE-M	Gomito banjo – Estremità conica EO 24°/Filettatura maschio metrica
SWVE-R	Gomito banjo – Estremità conica EO 24°/Filettatura maschio BSPP
T	Raccordo intermedio a T – Estremità conica EO 24°
TEE	Gomito orientabile con dado di bloccaggio – EO 24°/filettatura orientabile
TE-M	T di linea con terminale maschio – Estremità conica EO 24°/Filettatura maschio metrica – bordo di tenuta metallico (ISO 9974)
TE-M (KEG)	T di linea con terminale maschio – Estremità conica EO 24°/Filettatura maschio metrica conica corta (DIN 3852-1, tipo C)
TE-R	T di linea con terminale maschio – Estremità conica EO 24°/Filettatura maschio BSPP – bordo di tenuta metallico (ISO 1179)
TE-R (KEG)	T di linea con terminale maschio – Estremità conica EO 24°/Filettatura maschio BSP conica corta (DIN 3852-2, tipo C)
TH-M	T banjo per alte pressioni – Estremità conica EO 24°/Filettatura maschio metrica con anello di tenuta in metallico
TH-M-KDS	T banjo per alte pressioni – Estremità conica EO 24°/Filettatura maschio metrica con anello di tenuta in gomma
TH-R	T banjo per alte pressioni – Estremità conica EO 24°/Filettatura maschio BSPP con anello di tenuta metallico
TH-R-KDS	T banjo per alte pressioni – Estremità conica EO 24°/Filettatura maschio BSPP con anello di tenuta in gomma
TR	Raccordo riduzione a T – Estremità conica EO 24°
VEE	Gomito orientabile con dado di bloccaggio – EO 24°/filettatura orientabile
VH	Ghiera di rinforzo – Per tubature metalliche con pareti sottili
VKA	Tappo protettivo per coni – Dado girevole EO 24° DKO
VKAM	Tappo protettivo con dado per coni – Dado girevole EO 24° DKO
VSTI M/R-ED	Tappo protettivo per connessioni – Filettatura maschio metrica – Guarnizione ES (ISO 9974)/Filettatura maschio BSPP – Guarnizione ED (ISO 1179)
VSTI M-OR	Tappo protettivo per connessioni – Filettatura maschio metrica – O-ring (ISO 6149)
W	Raccordo intermedio a gomito – Estremità conica EO 24°
WEE	Gomito orientabile con dado di bloccaggio – EO 24°/filettatura orientabile
WE-M	Gomito con terminale maschio – Estremità conica EO 24°/Filettatura maschio metrica – bordo di tenuta metallico (ISO 9974)
WE-M (KEG)	Gomito con terminale maschio – Estremità conica EO 24°/Filettatura maschio metrica conica corta (DIN 3852-1, tipo C)
WE-NPT	Gomito con terminale maschio – Estremità conica EO 24°/Filettatura maschio NPT (SAE J476)
WE-R	Gomito con terminale maschio – Estremità conica EO 24°/Filettatura maschio BSPP – bordo di tenuta metallico (ISO 1179)
WE-R (KEG)	Gomito con terminale maschio – Estremità conica EO 24°/Filettatura maschio BSP conica corta (DIN 3852-2, tipo C)
WH-M	Gomito banjo per alte pressioni – Estremità conica EO 24°/Filettatura maschio metrica con anello di tenuta metallico
WH-M-KDS	Gomito banjo per alte pressioni – Estremità conica EO 24°/Filettatura maschio metrica con anello di tenuta in gomma
WH-R	Gomito banjo alte pressioni – Estremità conica EO 24°/Filettatura maschio BSPP anello di tenuta metallico
WH-R-KDS	Gomito banjo per alte pressioni – Estremità conica EO 24°/Filettatura maschio BSPP con anello di tenuta in gomma
WSV	Gomito passaparatia – Estremità conica EO 24°
WH-R-KDS	Gomito banjo per alte pressioni – Estremità conica EO 24°/Filettatura maschio BSPP con anello di tenuta in gomma
WSV	Gomito passaparatia – Estremità conica EO 24°

FM Dado a duplice funzione EO2

per tubi in acciaio

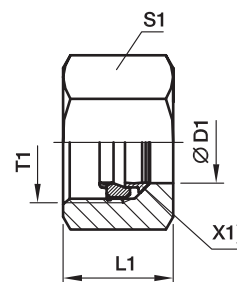

X1) Anello di ritenzione

Serie	D1 	T1	L1	S1	Codice di ordinazione				Peso g/1 pezzo	
					FM...CF Acciaio, zincato, esente da cromoVI passiv. + guarnizione NBR	PN (bar)	FM...VITCF Acciaio, zincato, esente da cromoVI passiv. + guarnizione FKM	PN (bar)		
LL	04	M 08×1,0	11,0	10	FM04LLCF	100	—	100	5	
	06	M 10×1,0	11,5	12	—	—	—	—	6	
L	06	M 12×1,5	14,5	14	FM06LCF	500	FM06LVITCF	500	12	
	08	M 14×1,5	14,5	17	FM08LCF	500	FM08LVITCF	500	17	
	10	M 16×1,5	15,5	19	FM10LCF	500	FM10LVITCF	500	22	
	12	M 18×1,5	15,5	22	FM12LCF	400	FM12LVITCF	400	30	
	15	M 22×1,5	17,0	27	FM15LCF	400	FM15LVITCF	400	48	
	18	M 26×1,5	18,0	32	FM18LCF	400	FM18LVITCF	400	70	
	22	M 30×2,0	20,0	36	FM22LCF	250	FM22LVITCF	250	94	
	28	M 36×2,0	21,0	41	FM28LCF	250	FM28LVITCF	250	106	
	35	M 45×2,0	24,0	50	FM35LCF	250	FM35LVITCF	250	160	
	42	M 52×2,0	24,0	60	FM42LCF	250	FM42LVITCF	250	244	
	S	06	M 14×1,5	16,5	17	FM06SCF	800	FM06SVITCF	800	20
		08	M 16×1,5	16,5	19	FM08SCF	800	FM08SVITCF	800	23
10		M 18×1,5	17,5	22	FM10SCF	800	FM10SVITCF	800	37	
12		M 20×1,5	17,5	24	FM12SCF	630	FM12SVITCF	630	39	
14		M 22×1,5	20,5	27	FM14SCF	630	FM14SVITCF	630	60	
16		M 24×1,5	20,5	30	FM16SCF	630	FM16SVITCF	630	72	
20		M 30×2,0	24,0	36	FM20SCF	420	FM20SVITCF	420	121	
25		M 36×2,0	27,0	46	FM25SCF	420	FM25SVITCF	420	221	
30		M 42×2,0	29,0	50	FM30SCF	420	FM30SVITCF	420	248	
38		M 52×2,0	32,5	60	FM38SCF	420	FM38SVITCF	420	367	

$$\frac{\text{PN (bar)}}{10} = \text{PN (MPa)}$$

FM Dado a duplice funzione EO2

per tubi in acciaio inossidabile

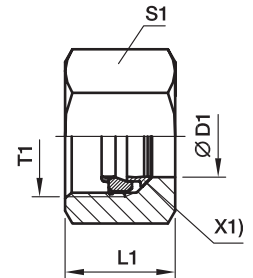

X1) Anello di ritenzione

Serie	D1 	T1	L1	S1	Codice di ordinazione								Peso g/1 pezzo	
					FM...71 Acciaio inossidabile		FM...NBR71 Acciaio inossidabile		Acciaio, zincato esente da cromoVI passiv. + guarnizione Anello di ritenzione: acciaio inossidabile Edelstahl		Acciaio, zincato esente da cromoVI passiv. + guarnizione Anello di ritenzione: acciaio inossidabile Edelstahl			
					Guarnizione FKM	PN (bar)	Guarnizione NBR	PN (bar)	Guarnizione NBR	PN (bar)	Guarnizione FKM	PN (bar)		
LL	04	M 08x1,0	11,0	10	—	—	—	—	FM04LLSSA	100	—	—	5	
	06	M 10x1,0	11,5	12	—	—	—	—	FM06LLSSA	100	—	—	6	
L	06	M 12x1,5	14,5	14	FM06L71	315	FM06LNBR71	315	FM06LSSA	315	FM06LVITSSA	315	12	
	08	M 14x1,5	14,5	17	FM08L71	315	FM08LNBR71	315	FM08LSSA	315	FM08LVITSSA	315	17	
	10	M 16x1,5	15,5	19	FM10L71	315	FM10LNBR71	315	FM10LSSA	315	FM10LVITSSA	315	22	
	12	M 18x1,5	15,5	22	FM12L71	315	FM12LNBR71	315	FM12LSSA	315	FM12LVITSSA	315	30	
	15	M 22x1,5	17,0	27	FM15L71	315	FM15LNBR71	315	FM15LSSA	315	FM15LVITSSA	315	48	
	18	M 26x1,5	18,0	32	FM18L71	315	FM18LNBR71	315	FM18LSSA	315	FM18LVITSSA	315	70	
	22	M 30x2,0	20,0	36	FM22L71	160	FM22LNBR71	160	FM22LSSA	160	FM22LVITSSA	160	94	
	28	M 36x2,0	21,0	41	FM28L71	160	FM28LNBR71	160	FM28LSSA	160	FM28LVITSSA	160	106	
	35	M 45x2,0	24,0	50	FM35L71	160	FM35LNBR71	160	FM35LSSA	160	FM35LVITSSA	160	160	
	42	M 52x2,0	24,0	60	FM42L71	160	FM42LNBR71	160	FM42LSSA	160	FM42LVITSSA	160	244	
	S	06	M 14x1,5	16,5	17	FM06S71	630	FM06SNBR71	630	FM06SSSA	630	FM06SVITSSA	630	20
		08	M 16x1,5	16,5	19	FM08S71	630	FM08SNBR71	630	FM08SSSA	630	FM08SVITSSA	630	23
10		M 18x1,5	17,5	22	FM10S71	630	FM10SNBR71	630	FM10SSSA	630	FM10SVITSSA	630	37	
12		M 20x1,5	17,5	24	FM12S71	630	FM12SNBR71	630	FM12SSSA	630	FM12SVITSSA	630	39	
14		M 22x1,5	20,5	27	FM14S71	630	FM14SNBR71	630	FM14SSSA	630	FM14SVITSSA	630	60	
16		M 24x1,5	20,5	30	FM16S71	400	FM16SNBR71	400	FM16SSSA	400	FM16SVITSSA	400	72	
20		M 30x2,0	24,0	36	FM20S71	400	FM20SNBR71	400	FM20SSSA	400	FM20SVITSSA	400	121	
25		M 36x2,0	27,0	46	FM25S71	400	FM25SNBR71	400	FM25SSSA	400	FM25SVITSSA	400	221	
30		M 42x2,0	29,0	50	FM30S71	400	FM30SNBR71	400	FM30SSSA	400	FM30SVITSSA	400	248	
38		M 52x2,0	32,5	60	FM38S71	315	FM38SNBR71	315	FM38SSSA	315	FM38SVITSSA	315	367	

$$\frac{\text{PN (bar)}}{10} = \text{PN (MPa)}$$

Dado a duplice funzione EO2-FORM

per tubi in acciaio

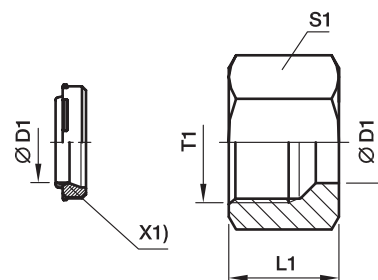

X1) Guarnizione (DOZ)

Serie	D1 	T1	L1	S1	Codice di ordinazione		PN (bar)	Peso g/1 pezzo
					FORM...CF Acciaio, zincato essente da cromoVI + guarnizione NBR	FORM...VITCF Acciaio, zincato essente da cromoVI + guarnizione FKM		
L	06	M 12×1,5	14,5	14	FORM06LCF	FORM06LVITCF	500	11
	08	M 14×1,5	14,5	17	FORM08LCF	FORM08LVITCF	500	16
	10	M 16×1,5	15,5	19	FORM10LCF	FORM10LVITCF	500	20
	12	M 18×1,5	15,5	22	FORM12LCF	FORM12LVITCF	400	27
	15	M 22×1,5	17,0	27	FORM15LCF	FORM15LVITCF	400	45
	18	M 26×1,5	18,0	32	FORM18LCF	FORM18LVITCF	400	67
	22	M 30×2,0	20,0	36	FORM22LCF	FORM22LVITCF	250	88
	28	M 36×2,0	21,0	41	FORM28LCF	FORM28LVITCF	250	99
	35	M 45×2,0	24,0	50	FORM35LCF	FORM35LVITCF	250	162
	42	M 52×2,0	24,0	60	FORM42LCF	FORM42LVITCF	250	233
S	06	M 14×1,5	16,5	17	FORM06SCF	FORM06SVITCF	800	19
	08	M 16×1,5	16,5	19	FORM08SCF	FORM08SVITCF	800	22
	10	M 18×1,5	17,5	22	FORM10SCF	FORM10SVITCF	800	34
	12	M 20×1,5	17,5	24	FORM12SCF	FORM12SVITCF	630	38
	14	M 22×1,5	20,5	27	FORM14SCF	FORM14SVITCF	630	57
	16	M 24×1,5	20,5	30	FORM16SCF	FORM16SVITCF	630	71
	20	M 30×2,0	24,0	36	FORM20SCF	FORM20SVITCF	420	115
	25	M 36×2,0	27,0	46	FORM25SCF	FORM25SVITCF	420	216
	30	M 42×2,0	29,0	50	FORM30SCF	FORM30SVITCF	420	242
	38	M 52×2,0	32,5	60	FORM38SCF	FORM38SVITCF	420	366

Dado a duplice funzione EO2-FORM

per tubi in acciaio inossidabile

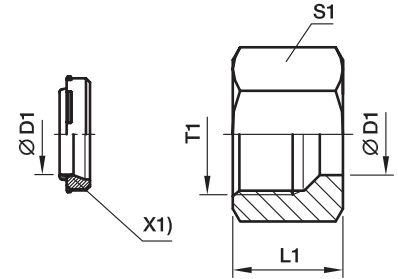

X1) Guarnizione (DOZ)

Serie	D1 	T1	L1	S1	Codice di ordinazione				PN (bar)	Peso g/1 pezzo
					FORM...71 Acciaio inossidabile Guarnizione FKM	FORM...NBR71 Acciaio inossidabile Guarnizione NBR	FORM...CF Acciaio, zincato esente da cromoVI passiv. + guarniz. Guarnizione NBR	FORM...VITCF Acciaio, zincato esente da cromoVI passiv. + guarniz. Guarnizione FKM		
L	06	M 12x1,5	14,5	14	FORM06L71	FORM06LNBR71	FORM06LCF	FORM06LVITCF	315	11
	08	M 14x1,5	14,5	17	FORM08L71	FORM08LNBR71	FORM08LCF	FORM08LVITCF	315	16
	10	M 16x1,5	15,5	19	FORM10L71	FORM10LNBR71	FORM10LCF	FORM10LVITCF	315	21
	12	M 18x1,5	15,5	22	FORM12L71	FORM12LNBR71	FORM12LCF	FORM12LVITCF	315	27
	15	M 22x1,5	17,0	27	FORM15L71	FORM15LNBR71	FORM15LCF	FORM15LVITCF	315	46
	18	M 26x1,5	18,0	32	FORM18L71	FORM18LNBR71	FORM18LCF	FORM18LVITCF	315	68
	22	M 30x2,0	20,0	36	FORM22L71	FORM22LNBR71	FORM22LCF	FORM22LVITCF	160	89
	28	M 36x2,0	21,0	41	FORM28L71	FORM28LNBR71	FORM28LCF	FORM28LVITCF	160	101
	35	M 45x2,0	24,0	50	FORM35L71	FORM35LNBR71	FORM35LCF	FORM35LVITCF	160	165
	42	M 52x2,0	24,0	60	FORM42L71	FORM42LNBR71	FORM42LCF	FORM42LVITCF	160	237
S	06	M 14x1,5	16,5	17	FORM06S71	FORM06SNBR71	FORM06SCF	FORM06SVITCF	630	19
	08	M 16x1,5	16,5	19	FORM08S71	FORM08SNBR71	FORM08SCF	FORM08SVITCF	630	22
	10	M 18x1,5	17,5	22	FORM10S71	FORM10SNBR71	FORM10SCF	FORM10SVITCF	630	35
	12	M 20x1,5	17,5	24	FORM12S71	FORM12SNBR71	FORM12SCF	FORM12SVITCF	630	39
	14	M 22x1,5	20,5	27	FORM14S71	FORM14SNBR71	FORM14SCF	FORM14SVITCF	630	58
	16	M 24x1,5	20,5	30	FORM16S71	FORM16SNBR71	FORM16SCF	FORM16SVITCF	400	71
	20	M 30x2,0	24,0	36	FORM20S71	FORM20SNBR71	FORM20SCF	FORM20SVITCF	400	117
	25	M 36x2,0	27,0	46	FORM25S71	FORM25SNBR71	FORM25SCF	FORM25SVITCF	400	219
	30	M 42x2,0	29,0	50	FORM30S71	FORM30SNBR71	FORM30SCF	FORM30SVITCF	400	246
	38	M 52x2,0	32,5	60	FORM38S71	FORM38SNBR71	FORM38SCF	FORM38SVITCF	315	372

M Dado · Estremità conica EO 24°

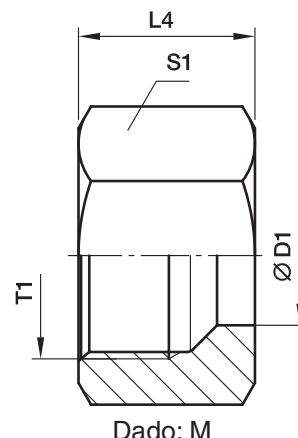

Serie	D1 	T1	L4	S1	Peso g/1 pezzo	Codice di ordinazione*	PN (bar) ¹⁾		
							CF	71	MS
LL ²⁾	04	M 08×1,0	11,0	10	4	M04LL	100	100	63
	06	M 10×1,0	11,5	12	6	M06LL	100	100	63
	08	M 12×1,0	12,0	14	7	M08LL	100	100	63
	10	M 14×1,0	12,5	17	11	M10LL	100	100	63
	12	M 16×1,0	13,0	19	13	M12LL	100	100	63
L ³⁾	06	M 12×1,5	14,5	14	10	M06L	500	315	200
	08	M 14×1,5	14,5	17	15	M08L	500	315	200
	10	M 16×1,5	15,5	19	18	M10L	500	315	200
	12	M 18×1,5	15,5	22	25	M12L	400	315	200
	15	M 22×1,5	17,0	27	42	M15L	400	315	200
	18	M 26×1,5	18,0	32	62	M18L	400	315	200
	22	M 30×2,0	20,0	36	82	M22L	250	160	100
	28	M 36×2,0	21,0	41	89	M28L	250	160	100
	35	M 45×2,0	24,0	50	137	M35L	250	160	100
	42	M 52×2,0	24,0	60	216	M42L	250	160	100
S ⁴⁾	06	M 14×1,5	16,5	17	17	M06S	800	630	400
	08	M 16×1,5	16,5	19	20	M08S	800	630	400
	10	M 18×1,5	17,5	22	31	M10S	800	630	400
	12	M 20×1,5	17,5	24	34	M12S	630	630	400
	14	M 22×1,5	20,5	27	53	M14S	630	630	400
	16	M 24×1,5	20,5	30	66	M16S	630	400	250
	20	M 30×2,0	24,0	36	102	M20S	420	400	250
	25	M 36×2,0	27,0	46	202	M25S	420	400	250
	30	M 42×2,0	29,0	50	219	M30S	420	400	250
	38	M 52×2,0	32,5	60	339	M38S	420	315	200

¹⁾ Pressione indicata = Articolo disponibile

²⁾ LL = Serie ultraleggera; ³⁾ L = Serie leggera; ⁴⁾ S = Serie pesante

$$\frac{\text{PN (bar)}}{10} = \text{PN (MPa)}$$

*Aggiungere i **suffissi** qui di seguito in base al materiale e alla superficie richiesti.

Suffissi codice di ordinazione		
Materiale	Suffisso superficie e materiale	Esempio
Acciaio, zincato, esente da CromoVI	CFX	M16SCFX
Acciaio inossidabile	EODURX	M16SEODURX
Ottone	MSX	M16SMSX

D Anello tagliente · PSR Anello ad arresto progressivo

per estremità conica EO 24°

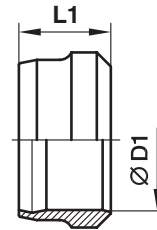
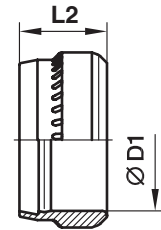

 Anello tagliente:
D

 Anello ad arresto
progressivo: PSR

Serie	D1	Anello tagliente D Codice di ordinazione						Anello progressivo PSR Codice di ordinazione			Peso g/ 1 pezzo	
		L1	Acciaio, zincato esente da cromoVI	PN (bar)	Acciaio	PN (bar)	Ottone	PN (bar)	L2	Acciaio, zincato esente da cromoVI		PN (bar)
LL	04	6,0	D04LLX	100	D04LL71X	100	D04LLMSX	63	—	—	—	0,3
	06	7,0	D06LLX	100	D06LL71X	100	D06LLMSX	63	—	—	—	0,8
	08	7,0	D08LLX	100	D08LL71X	100	D08LLMSX	63	—	—	—	1,0
	10	7,0	D10LLX	100	D10LL71X	100	D10LLMSX	63	—	—	—	1,3
	12	7,5	D12LLX	100	D12LL71X	100	D12LLMSX	63	—	—	—	1,6
L	06	9,5	—	—	—	—	D06LMSX	200	9,5	PSR06LX	500	1,7
	08	9,0	—	—	—	—	D08LMSX	200	9,5	PSR08LX	500	2,2
	10	10,0	—	—	—	—	D10LMSX	200	10,0	PSR10LX	500	3,1
	12	10,0	—	—	—	—	D12LMSX	200	10,0	PSR12LX	400	3,5
	15	10,0	—	—	—	—	D15LMSX	200	10,0	PSR15LX	400	4,5
	18	10,0	—	—	—	—	D18LMSX	200	10,0	PSR18LX	400	5,5
	22	10,5	—	—	—	—	D22LMSX	100	10,5	PSR22LX	250	7,3
	28	10,5	—	—	—	—	D28LMSX	100	10,5	PSR28LX	250	9,4
	35	13,0	—	—	—	—	D35LMSX	100	13,0	PSR35LX	250	20,0
	42	13,5	—	—	—	—	D42LMSX	100	13,0	PSR42LX	250	23,0
S	06	9,5	—	—	—	—	D06LMSX	400	9,5	PSR06LX	800	1,7
	08	9,0	—	—	—	—	D08LMSX	400	9,5	PSR08LX	800	3,2
	10	10,0	—	—	—	—	D10LMSX	400	10,0	PSR10LX	800	3,1
	12	10,0	—	—	—	—	D12LMSX	400	10,0	PSR12LX	630	3,5
	14	10,0	—	—	—	—	D14SMSX	400	10,0	PSR14SX	630	3,9
	16	10,5	—	—	—	—	D16SMSX	250	10,0	PSR16SX	630	5,6
	20	12,5	—	—	—	—	D20SMSX	250	13,0	PSR20SX	420	11,4
	25	12,5	—	—	—	—	D25SMSX	250	13,0	PSR25SX	420	13,3
	30	13,0	—	—	—	—	D30SMSX	250	13,0	PSR30SX	420	19,3
	38	13,5	—	—	—	—	D38SMSX	200	13,0	PSR38SX	420	22,5

$$\frac{\text{PN (bar)}}{10} = \text{PN (MPa)}$$

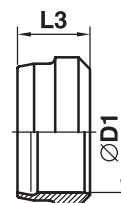
DPR Anello progressivo

Estremità conica EO 24°



Anello progressivo:
DPR

Serie	D1 	L3	Anello progressivo DPR Codice di ordinazione		PN (bar)	Peso g/1 pezzo
			Acciaio inossidabile	Acciaio inossidabile SPH		
L	06	9,0	DPR06L71X	DPR06LSPH71X	315	1,7
	08	9,0	DPR08L71X	DPR08LSPH71X	315	2,2
	10	9,5	DPR10L71X	DPR10LSPH71X	315	3,1
	12	9,8	DPR12L71X	DPR12LSPH71X	315	3,5
	15	9,5	DPR15L71X	DPR15LSPH71X	315	4,5
	18	9,5	DPR18L71X	DPR18LSPH71X	315	5,5
	22	10,5	DPR22L71X	DPR22LSPH71X	160	7,3
	28	11,0	DPR28L71X	DPR28LSPH71X	160	9,4
	35	13,5	DPR35L71X	DPR35LSPH71X	160	20,0
	42	13,5	DPR42L71X	DPR42LSPH71X	160	23,0
S	06	9,0	DPR06L71X	DPR06LSPH71X	630	1,7
	08	9,0	DPR08L71X	DPR08LSPH71X	630	3,2
	10	9,5	DPR10L71X	DPR10LSPH71X	630	3,1
	12	9,8	DPR12L71X	DPR12LSPH71X	630	3,5
	14	9,5	DPR14S71X	DPR14SSPH71X	630	3,9
	16	9,5	DPR16S71X	DPR16SSPH71X	400	5,6
	20	12,5	DPR20S71X	DPR20SSPH71X	400	11,4
	25	12,5	DPR25S71X	DPR25SSPH71X	400	13,3
	30	12,5	DPR30S71X	DPR30SSPH71X	400	19,3
	38	13,0	DPR38S71X	DPR38SSPH71X	315	22,5

$$\frac{PN \text{ (bar)}}{10} = PN \text{ (MPa)}$$

S Ghiera passante di bloccaggio

per fori filettatura in conformità a DIN 3854

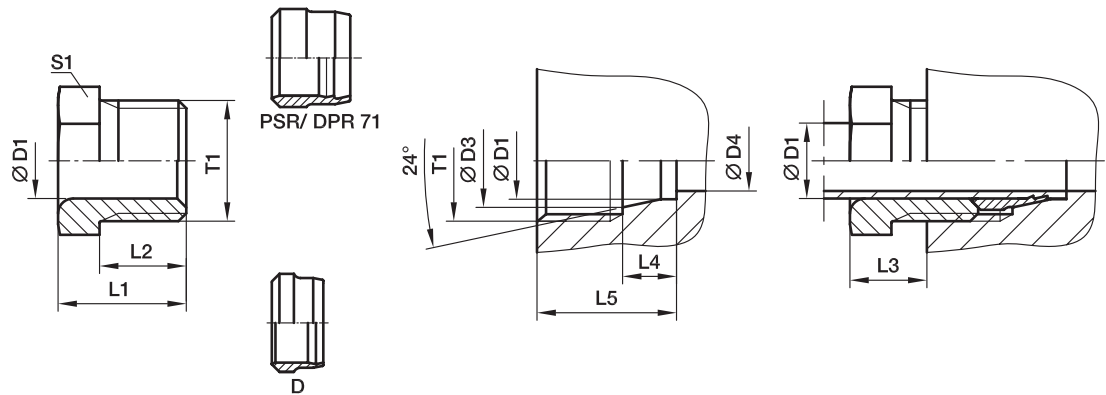

Serie	D1 	T1	D3	D4	L1	L2	L3	L4	L5	S1	Peso g/1 pezzo	Codice di ordinazione*	PN (bar) ¹⁾	
													CF	71
LL ²⁾	04	M 08×1,0	5,0	3,0	12	8,0	6	4,0	12,5	8	3	S04LL	100	100
	06	M 10×1,0	7,5	4,5	13	9,0	7	5,5	14,5	10	4	S06LL	100	100
	08	M 12×1,0	9,5	6,0	14	9,5	7	5,5	14,5	12	6	S08LL	100	100
L ³⁾	06	M 12×1,5	8,1	4,0	16	11,5	10	7,0	18,5	12	9	S06L	315	315
	08	M 14×1,5	10,1	6,0	16	11,5	10	7,0	18,5	14	11	S08L	315	315
	10	M 16×1,5	12,3	8,0	17	11,5	10	7,0	18,5	17	15	S10L	315	315
	12	M 18×1,5	14,3	10,0	18	12,0	10	7,0	19,0	19	19	S12L	315	315

¹⁾ Pressione indicata = Articolo disponibile

²⁾ LL = Serie ultraleggera; ³⁾ L = Serie leggera

$\frac{PN \text{ (bar)}}{10} = PN \text{ (MPa)}$

*Aggiungere i **suffissi** qui di seguito in base al materiale e alla superficie richiesti.

Suffissi codice di ordinazione		
Materiale	Suffisso superficie e materiale	Esempio
Acciaio, zincato, esente da CromoVI	CFX	S10LCFX
Acciaio inossidabile	71X	S10L71X

G Raccordo intermedio

Estremità conica EO 24°

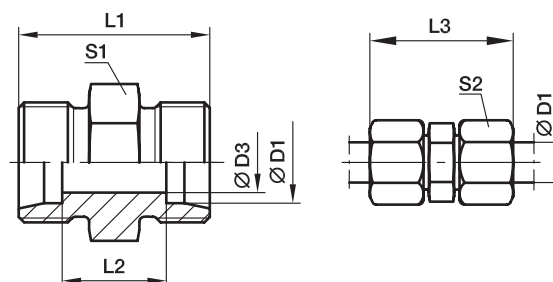

Serie	D1 	D3	L1	L2	L3	S1	S2	Peso g/1 pezzo	Codice di ordinazione*	PN (bar) ¹⁾		
										CF	71	MS
LL ²⁾	04	3,0	20	12	31	9	10	5	G04LL	100	100	63
	06	4,5	20	9	32	11	12	7	G06LL	100	100	63
	08	6,0	23	12	35	12	14	10	G08LL	100	100	63
	10	8,0	23	12	35	14	17	13	G10LL	100	100	63
	12	10,0	23	11	35	17	19	16	G12LL	100	100	63
L ³⁾	06	4,0	24	10	39	12	14	12	G06L	500	315	200
	08	6,0	25	11	40	14	17	16	G08L	500	315	200
	10	8,0	27	13	42	17	19	23	G10L	500	315	200
	12	10,0	28	14	43	19	22	28	G12L	400	315	200
	15	12,0	30	16	46	24	27	51	G15L	400	315	200
	18	15,0	31	16	48	27	32	69	G18L	400	315	200
	22	19,0	35	20	52	32	36	90	G22L	250	160	100
	28	24,0	36	21	54	41	41	137	G28L	250	160	100
	35	30,0	41	20	63	46	50	214	G35L	250	160	100
	42	36,0	43	21	66	55	60	296	G42L	250	160	100
S ⁴⁾	06	4,0	30	16	45	14	17	26	G06S	800	630	400
	08	5,0	32	18	47	17	19	37	G08S	800	630	400
	10	7,0	32	17	49	19	22	44	G10S	800	630	400
	12	8,0	34	19	51	22	24	60	G12S	630	630	400
	14	10,0	38	22	57	24	27	77	G14S	630	630	400
	16	12,0	38	21	57	27	30	90	G16S	630	400	250
	20	16,0	44	23	66	32	36	143	G20S	420	400	250
	25	20,0	50	26	74	41	46	251	G25S	420	400	250
	30	25,0	54	27	80	46	50	330	G30S	420	400	250
	38	32,0	61	29	90	55	60	545	G38S	420	315	200

¹⁾ Pressione indicata = Articolo disponibile

²⁾ LL = Serie ultraleggera; ³⁾ L = Serie leggera; ⁴⁾ S = Serie pesante

$$\frac{PN \text{ (bar)}}{10} = PN \text{ (MPa)}$$

Consegna senza dado né anello. Per informazioni sull'ordinazione di raccordi completi vedere pag. 17.

*Aggiungere i **suffissi** qui di seguito in base al materiale e alla superficie richiesti.

Suffissi codice di ordinazione		
Materiale	Suffisso superficie e materiale	Esempio
Acciaio, zincato, esente da CromoVI	CFX	G16SCFX
Acciaio inossidabile	71X	G16S71X
Ottone	MSX	G16SMSX

GR Raccordo riduzione diretto

Estremità conica EO 24°

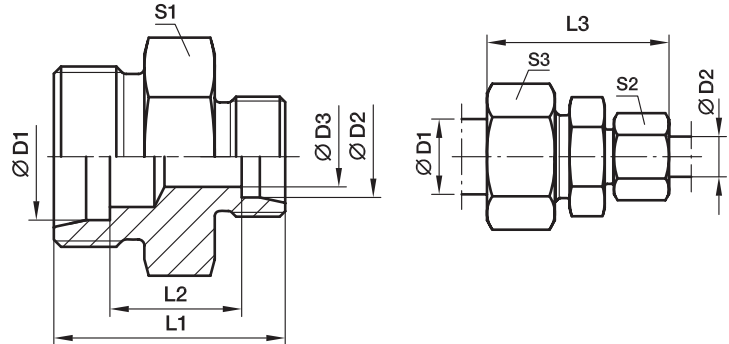

Serie	D1	D2	D3	L1	L2	L3	S1	S2	S3	Peso g/1 pezzo	Codice di ordinazione*	PN (bar) ¹⁾			
												CF	71	MS	
LL ²⁾	06	04	3,0	20	10,5	32	11	10	12	7	GR06/04LL	100	100	63	
	08	04	3,0	22	12,5	34	12	10	14	9	GR08/04LL	100	100	63	
	08	06	4,5	22	11,0	34	12	12	14	11	GR08/06LL	100	100	63	
L ³⁾	08	06	4,0	25	11,0	40	14	14	17	16	GR08/06L	500	315	200	
	10	06	4,0	26	12,0	41	17	14	19	21	GR10/06L	500	315	200	
	10	08	6,0	26	12,0	41	17	17	19	21	GR10/08L	500	315	200	
	12	06	4,0	27	13,0	42	19	14	22	26	GR12/06L	400	315	200	
	12	08	6,0	27	13,0	42	19	17	22	26	GR12/08L	400	315	200	
	12	10	8,0	28	14,0	43	19	19	22	29	GR12/10L	400	315	200	
	15	10	8,0	29	15,0	45	24	19	27	46	GR15/10L	400	315	200	
	15	12	10,0	29	15,0	45	24	22	27	45	GR15/12L	400	315	200	
	18	10	8,0	30	15,5	46	27	19	32	65	GR18/10L	400	315	200	
	18	12	10,0	30	15,5	46	27	22	32	64	GR18/12L	400	315	200	
	18	15	12,0	31	16,5	48	27	27	32	65	GR18/15L	400	315	200	
	22	12	10,0	32	17,5	48	32	22	36	80	GR22/12L	250	160	100	
	22	15	12,0	33	18,5	50	32	27	36	89	GR22/15L	250	160	100	
	22	18	15,0	33	18,0	50	32	32	36	89	GR22/18L	250	160	100	
	28	18	15,0	34	19,0	52	41	32	41	142	GR28/18L	250	160	100	
	28	22	19,0	36	21,0	54	41	36	41	139	GR28/22L	250	160	100	
	35	22	19,0	39	21,0	59	46	36	50	202	GR35/22L	250	160	100	
	35	28	24,0	39	21,0	59	46	41	50	206	GR35/28L	250	160	100	
	42	35	30,0	43	21,5	66	55	50	60	330	GR42/35L	250	160	100	
	S ⁴⁾	08	06	4,0	32	18,0	47	17	17	19	35	GR08/06S	800	630	400
		10	06	4,0	32	17,5	48	19	17	22	41	GR10/06S	800	630	400
		10	08	5,0	32	17,5	48	19	19	22	42	GR10/08S	800	630	400
		12	06	4,0	34	19,5	50	22	17	24	56	GR12/06S	630	630	400
		12	08	5,0	34	19,5	50	22	19	24	57	GR12/08S	630	630	400
12		10	7,0	34	19,0	51	22	22	24	59	GR12/10S	630	630	400	
14		10	7,0	36	20,5	54	24	22	27	70	GR14/10S	630	630	400	
14		12	8,0	36	20,5	54	24	24	27	72	GR14/12S	630	630	400	
16		10	7,0	36	20,0	54	27	22	30	80	GR16/10S	630	400	250	
16		12	8,0	36	20,0	54	27	24	30	87	GR16/12S	630	400	250	
16		14	10,0	36	21,5	57	27	27	30	79	GR16/14S	630	400	250	
20		10	7,0	40	22,0	60	32	22	36	129	GR20/10S	420	400	250	
20		12	8,0	40	22,0	60	32	24	36	131	GR20/12S	420	400	250	
20		16	12,0	42	23,0	63	32	30	36	134	GR20/16S	420	400	250	
25		16	12,0	46	25,5	68	41	30	46	236	GR25/16S	420	400	250	
25		20	16,0	48	25,5	71	41	36	46	235	GR25/20S	420	400	250	
30		20	16,0	50	26,0	74	46	36	50	299	GR30/20S	420	400	250	
30		25	20,0	52	26,5	77	46	46	50	317	GR30/25S	420	400	250	
38		30	25,0	59	29,5	87	55	50	60	522	GR38/30S	420	315	200	

1) Pressione indicata = Articolo disponibile

2) LL = Serie ultraleggera; 3) L = Serie leggera;

4) S = Serie pesante

PN (bar)
10 = PN (MPa)

Consegna senza dado né anello. Per informazioni sull'ordinazione di raccordi completi vedere pag. 17.

*Aggiungere i suffissi qui di seguito in base al materiale e alla superficie richiesti.

Suffissi codice di ordinazione		
Materiale	Suffisso superficie e materiale	Esempio
Acciaio, zincato, esente da CromoVI	CFX	GR16/12SCFX
Acciaio inossidabile	71X	GR16/12S71X
Ottone	MSX	GR16/12SMSX

W Raccordo intermedio a gomito

Estremità conica EO 24°

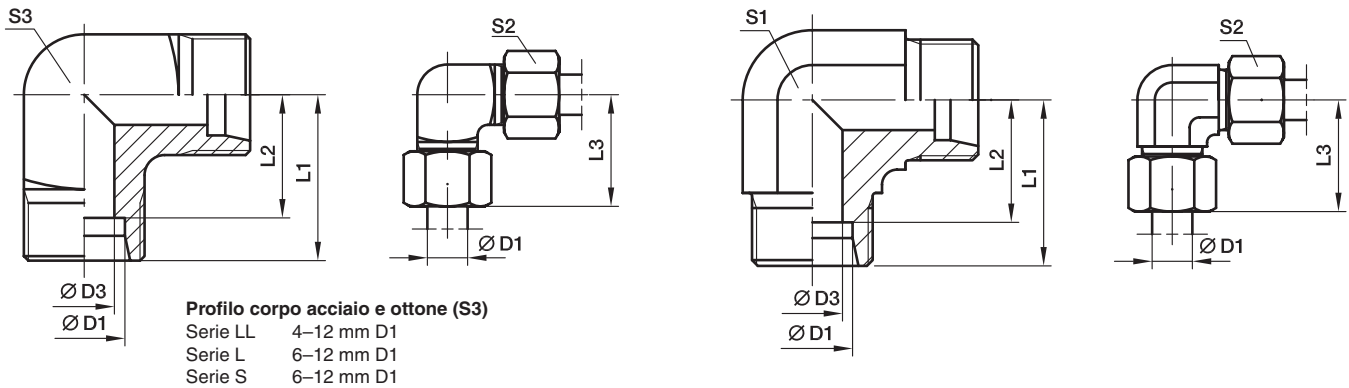

Serie	D1	D3	L1	L2	L3	S1	S2	S3	Peso g/1 pezzo	Codice di ordinazione*	PN (bar) ¹⁾		
											CF	71	MS
LL ²⁾	04	3,0	15	11,0	21	9	10	9	13	W04LL	100	100	63
	06	4,5	15	9,5	21	9	12	11	15	W06LL	100	100	63
	08	6,0	17	11,5	23	12	14	12	23	W08LL	100	100	63
	10	8,0	18	12,5	24	12	17	14	32	W10LL	100	100	63
	12	10,0	19	13,0	25	14	19	17	41	W12LL	100	100	63
L ³⁾	06	4,0	19	12,0	27	12	14	12	29	W06L	500	315	200
	08	6,0	21	14,0	29	12	17	14	43	W08L	500	315	200
	10	8,0	22	15,0	30	14	19	17	54	W10L	500	315	200
	12	10,0	24	17,0	32	19	22		80	W12L	400	315	200
	15	12,0	28	21,0	36	19	27		81	W15L	400	315	200
	18	15,0	31	23,5	40	24	32		140	W18L	400	315	200
	22	19,0	35	27,5	44	27	36		178	W22L	250	160	100
	28	24,0	38	30,5	47	36	41		340	W28L	250	160	100
	35	30,0	45	34,5	56	41	50		458	W35L	250	160	100
	42	36,0	51	40,0	63	50	60		776	W42L	250	160	100
S ⁴⁾	06	4,0	23	16,0	31	12	17	14	52	W06S	800	630	400
	08	5,0	24	17,0	32	14	19	17	74	W08S	800	630	400
	10	7,0	25	17,5	34	19	22		97	W10S	800	630	400
	12	8,0	29	21,5	38	17	24	22	137	W12S	630	630	400
	14	10,0	30	22,0	40	19	27		145	W14S	630	630	400
	16	12,0	33	24,5	43	24	30		162	W16S	630	400	250
	20	16,0	37	26,5	48	27	36		221	W20S	420	400	250
	25	20,0	42	30,0	54	36	46		424	W25S	420	400	250
	30	25,0	49	35,5	62	41	50		603	W30S	420	400	250
	38	32,0	57	41,0	72	50	60		1010	W38S	420	315	200

1) Pressione indicata = Articolo disponibile

2) LL = Serie ultraleggera; 3) L = Serie leggera; 4) S = Serie pesante

$$\frac{PN(\text{bar})}{10} = PN(\text{MPa})$$

Consegna senza dado né anello. Per informazioni sull'ordinazione di raccordi completi vedere pag. 17.

*Aggiungere i suffissi qui di seguito in base al materiale e alla superficie richiesti.

Suffissi codice di ordinazione		
Materiale	Suffisso superficie e materiale	Esempio
Acciaio, zincato, esente da CromoVI	CFX	W16SCFX
Acciaio inossidabile	71X	W16S71X
Ottone	MSX	W16SMSX

T Raccordo intermedio a T

Estremità conica EO 24°

Profilo corpo acciaio e ottone (S3)

Serie LL 4-10 mm D1

Serie L 6 + 8 mm D1

Serie S 6 mm D1

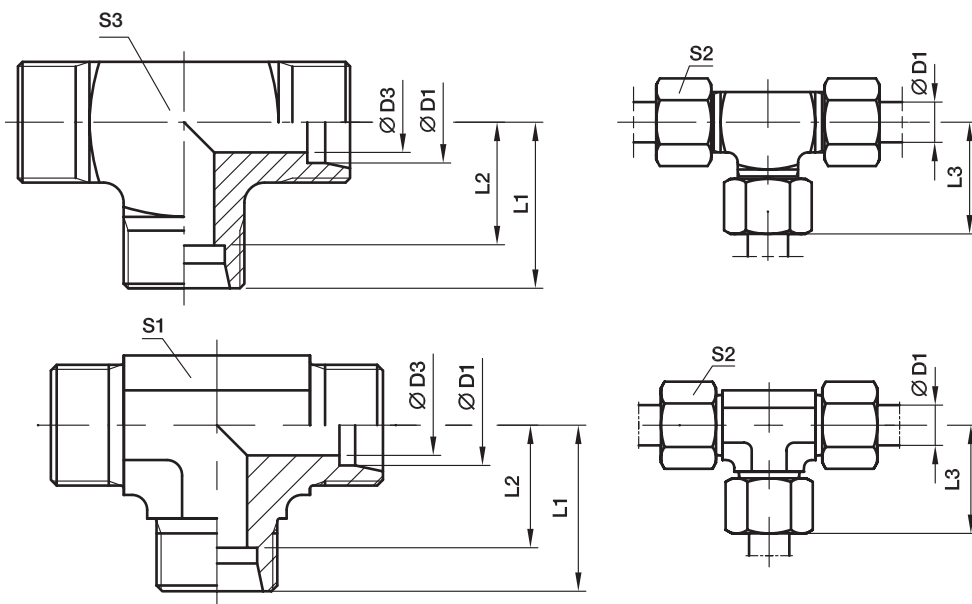

Serie	D1	D3	L1	L2	L3	S1	S2	S3	Peso g/1 pezzo	Codice di ordinazione*	PN (bar) ¹⁾		
											CF	71	MS
LL ²⁾	04	3,0	15	11,0	21	9	10	9	19	T04LL	100	100	63
	06	4,5	15	9,5	21	9	12	11	20	T06LL	100	100	63
	08	6,0	17	11,5	23	12	14	12	27	T08LL	100	100	63
	10	8,0	18	12,5	24	12	17	14	39	T10LL	100	100	63
	12	10,0	21	15,0	27	14	19		45	T12LL	100	100	63
L ³⁾	06	4,0	19	12,0	27	12	14	12	37	T06L	500	315	200
	08	6,0	21	14,0	29	12	17	14	53	T08L	500	315	200
	10	8,0	22	15,0	30	14	19		48	T10L	500	315	200
	12	10,0	24	17,0	32	17	22		65	T12L	400	315	200
	15	12,0	28	21,0	36	19	27		106	T15L	400	315	200
	18	15,0	31	23,5	40	24	32		179	T18L	400	315	200
	22	19,0	35	27,5	44	27	36		225	T22L	250	160	100
	28	24,0	38	30,5	47	36	41		396	T28L	250	160	100
	35	30,0	45	34,5	56	41	50		567	T35L	250	160	100
	42	36,0	51	40,0	63	50	60		905	T42L	250	160	100
S ⁴⁾	06	4,0	23	16,0	31	12	17	14	68	T06S	800	630	400
	08	5,0	24	17,0	32	14	19		70	T08S	800	630	400
	10	7,0	25	17,5	34	17	22		91	T10S	800	630	400
	12	8,0	29	21,5	38	17	24		117	T12S	630	630	400
	14	10,0	30	22,0	40	19	27		136	T14S	630	630	400
	16	12,0	33	24,5	43	24	30		202	T16S	630	400	250
	20	16,0	37	26,5	48	27	36		289	T20S	420	400	250
	25	20,0	42	30,0	54	36	46		545	T25S	420	400	250
	30	25,0	49	35,5	62	41	50		758	T30S	420	400	250
	38	32,0	57	41,0	72	50	60		1264	T38S	420	315	200

¹⁾ Pressione indicata = Articolo disponibile

²⁾ LL = Serie ultraleggera; ³⁾ L = Serie leggera;

⁴⁾ S = Serie pesante

$$\frac{PN \text{ (bar)}}{10} = PN \text{ (MPa)}$$

Consegna senza dado né anello. Per informazioni sull'ordinazione di raccordi completi vedere pag. 17.

*Aggiungere i **suffissi** qui di seguito in base al materiale e alla superficie richiesti.

Suffissi codice di ordinazione		
Materiale	Suffisso superficie e materiale	Esempio
Acciaio, zincato, esente da CromoVI	CFX	T16SCFX
Acciaio inossidabile	71X	T16S71X
Ottone	MSX	T16SMSX

TR Raccordo riduzione a T

Estremità conica
EO 24°

Profilo corpo acciaio e ottone (S1)

Serie LL 4-8 mm D1, D2, D3

Serie L 6+8 mm D1, D2, D3

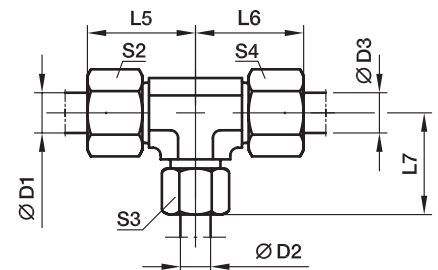
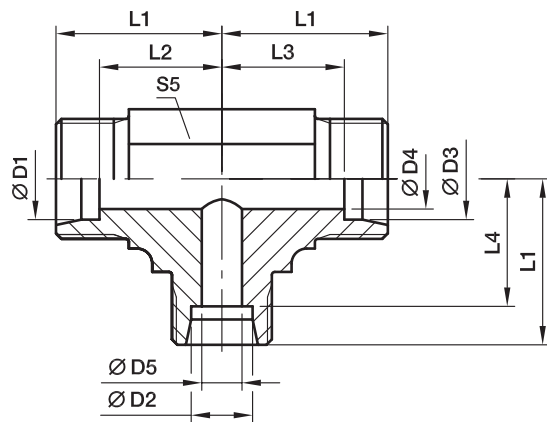
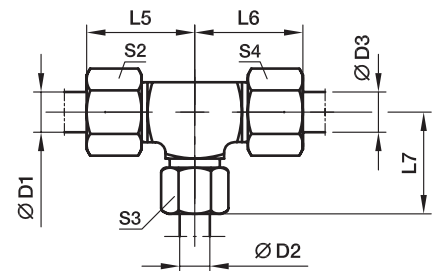
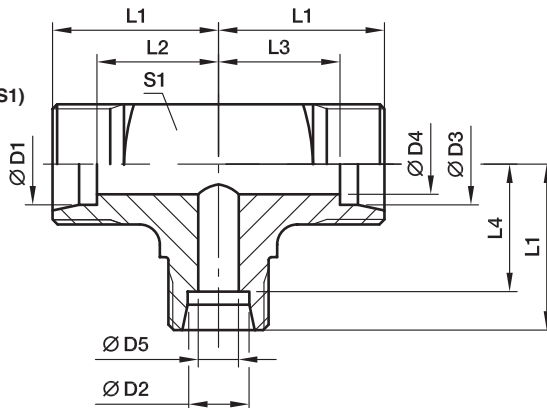

Serie	D1, D2, D3			D4	D5	L1	L2	L3	L4	L5	L6	L7	S1	S2	S3	S4	S5	Peso g/1 pezzo	Codice di ordinazione*	PN (bar) ¹⁾		
	CF	71	MS																			
LL ²⁾	04	08	04	3,0	6	17	13,0	13,0	11,5	23	23	23	12	10	14	10	12	27	TR04/08/04LL	100	100	63
	06	04	06	4,5	3	15	9,5	9,5	11,0	21	21	21	11	12	10	12	9	18	TR06/04/06LL	100	100	63
L ³⁾	06	08	06	4,0	6	21	14,0	14,0	14,0	29	29	29	14	14	17	14	12	54	TR06/08/06L	500	315	200
	08	06	08	6,0	4	21	14,0	14,0	14,0	29	29	29	14	17	14	17	12	53	TR08/06/08L	500	315	200
	06	10	06	4,0	8	22	15,0	15,0	15,0	30	30	30		14	19	14	14	53	TR06/10/06L	500	315	200
	08	10	08	6,0	8	22	15,0	15,0	15,0	30	30	30		17	19	17	14	50	TR08/10/08L	500	315	200
	10	06	10	8,0	4	22	15,0	15,0	15,0	30	30	30		19	14	19	14	46	TR10/06/10L	500	315	200
	10	08	10	8,0	6	22	15,0	15,0	15,0	30	30	30		19	17	19	14	43	TR10/08/10L	500	315	200
	10	10	06	4,0	8	22	15,0	15,0	15,0	30	30	30		19	19	14	14	49	TR10/10/06L	500	315	200
	08	12	08	6,0	10	24	17,0	17,0	17,0	32	32	32		17	22	17	17	67	TR08/12/08L	400	315	200
	12	06	12	10,0	4	24	17,0	17,0	17,0	32	32	32		22	14	22	17	66	TR12/06/12L	400	315	200
	12	08	08	6,0	6	24	17,0	17,0	17,0	32	32	32		22	17	17	17	66	TR12/08/08L	400	315	200
	12	08	12	10,0	6	24	17,0	17,0	17,0	32	32	32		22	17	22	17	68	TR12/08/12L	400	315	200
	12	10	10	8,0	8	24	17,0	17,0	17,0	32	32	32		22	19	19	17	67	TR12/10/10L	400	315	200
	12	10	12	10,0	8	24	17,0	17,0	17,0	32	32	32		22	19	22	17	67	TR12/10/12L	400	315	200
	12	12	10	8,0	10	24	17,0	17,0	17,0	32	32	32		22	22	19	17	64	TR12/12/10L	400	315	200
	10	15	10	8,0	12	28	21,0	21,0	21,0	36	36	36		19	27	19	19	105	TR10/15/10L	400	315	200
	12	15	12	10,0	12	28	21,0	21,0	21,0	36	36	36		22	27	22	19	102	TR12/15/12L	400	315	200
	15	06	15	12,0	4	28	21,0	21,0	21,0	36	36	36		27	14	27	19	107	TR15/06/15L	400	315	200
	15	10	15	12,0	8	28	21,0	21,0	21,0	36	36	36		27	19	27	19	105	TR15/10/15L	400	315	200
	15	12	12	10,0	10	28	21,0	21,0	21,0	36	36	36		27	22	22	19	101	TR15/12/12L	400	315	200
	15	12	15	12,0	10	28	21,0	21,0	21,0	36	36	36		27	22	27	19	105	TR15/12/15L	400	315	200
15	15	12	10,0	12	28	21,0	21,0	21,0	36	36	36		27	27	22	19	103	TR15/15/12L	400	315	200	
12	18	12	10,0	15	31	24,0	24,0	23,5	39	39	40		22	32	22	24	177	TR12/18/12L	400	315	200	
18	10	10	8,0	8	31	23,5	24,0	24,0	40	39	39		32	19	19	24	173	TR18/10/10L	400	315	200	
18	10	18	15,0	8	31	23,5	23,5	24,0	40	40	39		32	19	32	24	182	TR18/10/18L	400	315	200	
18	12	18	15,0	10	31	23,5	23,5	24,0	40	40	39		32	22	32	24	174	TR18/12/18L	400	315	200	

TR Raccordo riduzione a T

 Estremità conica
 EO 24°

Serie	D1	D2	D3	D4	D5	L1	L2	L3	L4	L5	L6	L7	S1	S2	S3	S4	S5	Peso g/1 pezzo	Codice di ordinazione*	PN (bar) ¹⁾			
																				CF	71	MS	
L ³⁾	18	15	18	15,0	12	31	23,5	23,5	24,0	40	40	39		32	27	32	24	179	TR18/15/18L	400	315	200	
	18	18	10	8,0	15	31	23,5	24,0	23,5	40	39	40		32	32	19	24	171	TR18/18/10L	400	315	200	
	22	10	22	19,0	8	35	27,5	27,5	28,0	44	44	43		36	19	36	27	232	TR22/10/22L	250	160	100	
	22	12	22	19,0	10	35	27,5	27,5	28,0	44	44	43		36	22	36	27	229	TR22/12/22L	250	160	100	
	22	15	15	12,0	12	35	27,5	28,0	28,0	44	43	43		36	27	27	27	240	TR22/15/15L	250	160	100	
	22	15	22	19,0	12	35	27,5	27,5	28,0	44	44	43		36	27	36	27	233	TR22/15/22L	250	160	100	
	22	18	18	15,0	15	35	27,5	27,5	27,5	44	44	44		36	32	32	27	236	TR22/18/18L	250	160	100	
	22	18	22	19,0	15	35	27,5	27,5	27,5	44	44	44		36	32	36	27	239	TR22/18/22L	250	160	100	
	22	22	18	15,0	19	35	27,5	27,5	27,5	44	44	44		36	36	32	27	228	TR22/22/18L	250	160	100	
	28	10	28	24,0	8	38	30,5	30,5	31,0	47	47	46		41	19	41	36	412	TR28/10/28L	250	160	100	
	28	12	28	24,0	10	38	30,5	30,5	31,0	47	47	46		41	22	41	36	408	TR28/12/28L	250	160	100	
	28	15	28	24,0	12	38	30,5	30,5	31,0	47	47	46		41	27	41	36	423	TR28/15/28L	250	160	100	
	28	18	28	24,0	15	38	30,5	30,5	30,5	47	47	47		41	32	41	36	421	TR28/18/28L	250	160	100	
	28	22	22	19,0	19	38	30,5	30,5	30,5	47	47	47		41	36	36	36	412	TR28/22/22L	250	160	100	
	28	22	28	24,0	19	38	30,5	30,5	30,5	47	47	47		41	36	41	36	415	TR28/22/28L	250	160	100	
	S ⁴⁾	10	06	10	7,0	4	25	17,5	17,5	18,0	34	34	33		22	17	22	17	103	TR10/06/10S	800	630	400
		12	08	08	5,0	5	29	21,5	22,0	22,0	38	37	37		24	19	19	17	107	TR12/08/08S	630	630	400
		12	08	12	8,0	5	29	21,5	21,5	22,0	38	38	37		24	19	24	17	105	TR12/08/12S	630	630	400
		12	10	12	8,0	7	29	21,5	21,5	21,5	38	38	38		24	22	24	17	114	TR12/10/12S	630	630	400
		12	16	12	8,0	12	33	25,5	25,5	24,5	42	42	43		24	30	24	24	190	TR12/16/12S	630	400	250
		16	06	16	12,0	4	33	24,5	24,5	26,0	43	43	41		30	17	30	24	176	TR16/06/16S	630	400	250
		16	08	16	12,0	5	33	24,5	24,5	26,0	43	43	41		30	19	30	24	208	TR16/08/16S	630	400	250
		16	10	16	12,0	7	33	24,5	24,5	25,5	43	43	42		30	22	30	24	210	TR16/10/16S	630	400	250
		16	12	16	12,0	8	33	24,5	24,5	25,5	43	43	42		30	24	30	24	386	TR16/12/16S	630	400	250
16		20	16	12,0	16	37	28,5	28,5	26,5	47	47	48		30	36	30	27	296	TR16/20/16S	420	400	250	
20		10	20	16,0	7	37	26,5	26,5	29,5	48	48	46		36	22	36	27	553	TR20/10/20S	420	400	250	
20		12	20	16,0	8	37	26,5	26,5	29,5	48	48	46		36	24	36	27	306	TR20/12/20S	420	400	250	
20		16	20	16,0	12	37	26,5	26,5	28,5	48	48	47		36	30	36	27	285	TR20/16/20S	420	400	250	
20		25	20	16,0	20	42	31,5	31,5	30,0	53	53	54		36	46	36	36	544	TR20/25/20S	420	400	250	
25		16	25	20,0	12	42	30,0	30,0	33,5	54	54	52		46	30	46	36	556	TR25/16/25S	420	400	250	
25		20	25	20,0	16	42	30,0	30,0	31,5	54	54	53		46	36	46	36	544	TR25/20/25S	420	400	250	
25		30	25	20,0	25	49	37,0	37,0	35,5	61	61	62		46	50	46	41	791	TR25/30/25S	420	400	250	

1) Pressione indicata = Articolo disponibile

2) LL = Serie ultraleggera; 3) L = Serie leggera; 4) S = Serie pesante

$$\frac{\text{PN (bar)}}{10} = \text{PN (MPa)}$$
Consegna senza dado né anello. Per informazioni sull'ordinazione di raccordi completi vedere pag. 17.

 *Aggiungere i **suffissi** qui di seguito in base al materiale e alla superficie richiesti.

Suffissi codice di ordinazione		
Materiale	Suffisso superficie e materiale	Esempio
Acciaio, zincato, esente da CromoVI	CFX	TR16/12/16SCFX
Acciaio inossidabile	71X	TR16/12/16S71X
Ottone	MSX	TR16/12/16SMSX

K Raccordo intermedio a croce

Estremità conica EO 24°

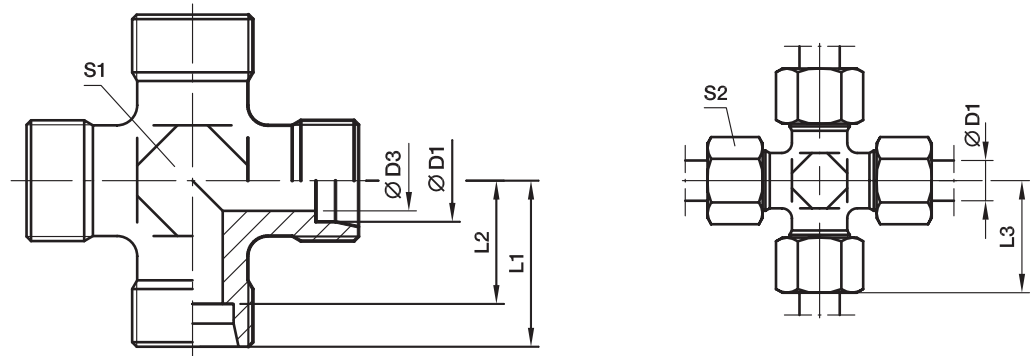

Serie	D1	D3	L1	L2	L3	S1	S2	Peso g/1 pezzo	Codice di ordinazione*	PN (bar) ¹⁾		
										CF	71	MS
LL ²⁾	04	3,0	15	11,0	21	9	10	13	K04LL	100	100	63
	06	4,5	15	9,5	21	9	12	14	K06LL	100	100	63
	08	6,0	17	11,5	23	12	14	24	K08LL	100	100	63
L ³⁾	06	4,0	19	12,0	27	12	14	35	K06L	315	315	200
	08	6,0	21	14,0	29	12	17	40	K08L	315	315	200
	10	8,0	22	15,0	30	14	19	52	K10L	315	315	200
	12	10,0	24	17,0	32	17	22	69	K12L	315	315	200
	15	12,0	28	21,0	36	19	27	130	K15L	315	315	200
	18	15,0	31	23,5	40	24	32	188	K18L	315	315	200
	22	19,0	35	27,5	44	27	36	251	K22L	160	160	100
	28	24,0	38	30,5	47	36	41	392	K28L	160	160	100
	35	30,0	45	34,5	56	41	50	618	K35L	160	160	100
	42	36,0	51	40,0	63	50	60	905	K42L	160	160	100
S ⁴⁾	06	4,0	23	16,0	31	12	17	58	K06S	630	630	400
	08	5,0	24	17,0	32	14	19	82	K08S	630	630	400
	10	7,0	25	17,5	34	17	22	97	K10S	630	630	400
	12	8,0	29	21,5	38	17	24	146	K12S	630	630	400
	14	10,0	30	22,0	40	19	27	176	K14S	400	400	250
	16	12,0	33	24,5	43	24	30	220	K16S	400	400	250
	20	16,0	37	26,5	48	27	36	339	K20S	315	315	200
	25	20,0	42	30,0	54	36	46	576	K25S	315	315	200
	30	25,0	49	35,5	62	41	50	843	K30S	315	315	200
	38	32,0	57	41,0	72	50	60	1350	K38S	315	315	200

¹⁾ Pressione indicata = Articolo disponibile

²⁾ LL = Serie ultraleggera; ³⁾ L = Serie leggera; ⁴⁾ S = Serie pesante

$$\frac{PN \text{ (bar)}}{10} = PN \text{ (MPa)}$$

Consegna senza dado né anello. Per informazioni sull'ordinazione di raccordi completi vedere pag. 17.

*Aggiungere i **suffixi** qui di seguito in base al materiale e alla superficie richiesti.

Suffixi codice di ordinazione		
Materiale	Suffixo superficie e materiale	Esempio
Acciaio, zincato, esente da CromoVI	CFX	K16SCFX
Acciaio inossidabile	71X	K16S71X
Ottone	MSX	K16SMSX

SV Raccordo intermedio passaparatia

Estremità conica EO 24°

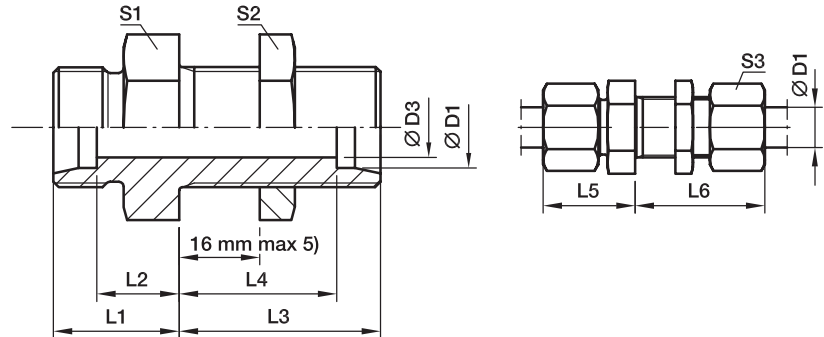

Serie	D1	D3	L1	L2	L3	L4	L5	L6	S1	S2	S3	Peso g/1 pezzo	Codice di ordinazione*	PN (bar) ¹⁾			
														CF	71	MS	
L ³⁾	06	4	14	7,0	34	27,0	22	42	17	17	14	39	SV06LOMD	500	315	200	
	08	6	15	8,0	34	27,0	23	42	19	19	17	50	SV08LOMD	500	315	200	
	10	8	17	10,0	35	28,0	25	43	22	22	19	67	SV10LOMD	500	315	200	
	12	10	17	10,0	36	29,0	25	44	24	24	22	78	SV12LOMD	400	315	200	
	15	12	19	12,0	38	31,0	27	46	27	30	27	128	SV15LOMD	400	315	200	
	18	15	21	13,5	40	32,5	30	49	32	36	32	198	SV18LOMD	400	315	200	
	22	19	24	16,5	42	34,5	33	51	36	41	36	254	SV22LOMD	250	160	100	
	28	24	26	18,5	43	35,5	35	52	41	46	41	335	SV28LOMD	250	160	100	
	35	30	29	18,5	47	36,5	40	58	50	55	50	546	SV35LOMD	250	160	160	
	42	36	30	19,0	47	36,0	42	59	60	65	60	758	SV42LOMD	250	160	160	
	S ⁴⁾	06	4	19	12,0	36	29,0	27	44	19	19	17	65	SV06SOMD	800	630	400
		08	5	20	13,0	36	29,0	28	44	22	22	19	87	SV08SOMD	800	630	400
		10	7	22	14,5	37	29,5	31	46	24	24	22	112	SV10SOMD	800	630	400
		12	8	22	14,5	38	30,5	31	47	27	27	24	141	SV12SOMD	630	630	400
14		10	25	17,0	40	32,0	35	50	30	30	27	180	SV14SOMD	630	630		
16		12	25	16,5	40	31,5	35	50	32	32	30	201	SV16SOMD	630	400	250	
20		16	28	17,5	44	33,5	39	55	41	41	36	462	SV20SOMD	420	400	250	
25		20	32	20,0	47	35,0	44	59	46	46	46	492	SV25SOMD	420	400	250	
30		25	35	21,5	51	37,5	48	64	50	50	50	631	SV30SOMD	420	400	250	
38		32	38	22,0	53	37,0	53	68	65	65	60	1083	SV38SOMD	420	315		

¹⁾ Pressione indicata = Articolo disponibile

³⁾ L = Serie leggera; ⁴⁾ S = Serie pesante

⁵⁾ Spessore minimo passaparatie.:

06-18 L e 06-16 S = 3 mm

22-42 L e 20-38 S = 4 mm

PN (bar)
10 = PN (MPa)

Consegna senza dado né anello. Per informazioni sull'ordinazione di raccordi completi vedere pag. 17.

*Aggiungere i suffissi qui di seguito in base al materiale e alla superficie richiesti.

Suffissi codice di ordinazione		
Materiale	Suffisso superficie e materiale	Esempio
Acciaio, zincato, esente da CromoVI	CF	SV16SOMDCF
Acciaio inossidabile	71	SV16SOMD71
Ottone	MS	SV16SOMDMS

WSV Gomito passaparatia

Estremità conica EO 24°

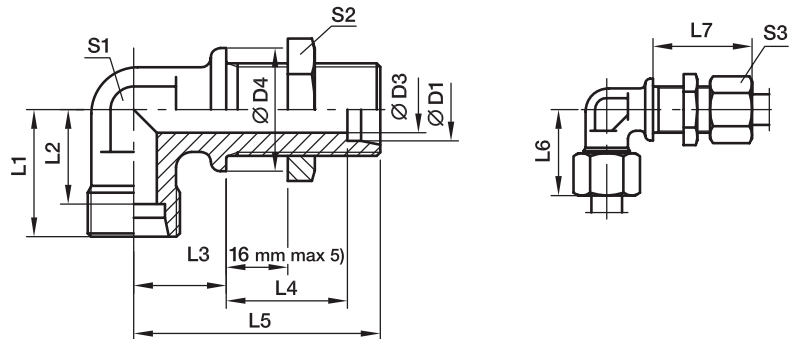

Serie	D1	D3	D4	L1	L2	L3	L4	L5	L6	L7	S1	S2	S3	Peso g/1 pezzo	Codice di ordinazione*	PN (bar) ¹⁾		
																CF	71	MS
L ³⁾	06	4	17	19	12,0	14	27,0	48	27	42	12	17	14	51	WSV06LOMD	315	315	200
	08	6	19	21	14,0	17	27,0	51	29	42	12	19	17	61	WSV08LOMD	315	315	200
	10	8	22	22	15,0	18	28,0	53	30	43	14	22	19	78	WSV10LOMD	315	315	200
	12	10	24	24	17,0	20	29,0	56	32	44	17	24	22	85	WSV12LOMD	315	315	200
	15	12	27	28	21,0	23	31,0	61	36	46	19	30	27	150	WSV15LOMD	315	315	200
	18	15	32	31	23,5	24	32,5	64	40	49	24	36	32	238	WSV18LOMD	315	315	200
	22	19	36	35	27,5	30	34,5	72	44	51	27	41	36	327	WSV22LOMD	160	160	
	28	24	42	38	30,5	34	35,5	77	47	52	36	46	41	482	WSV28LOMD	160	160	
	35	30	50	45	34,5	39	36,5	86	56	58	41	55	50	729	WSV35LOMD	160	160	
	42	36	60	51	40,0	43	36,0	90	63	59	50	65	60	1091	WSV42LOMD	160	160	
S ⁴⁾	06	4	19	23	16,0	17	29,0	53	31	44	12	19	17	72	WSV06SOMD	630	630	
	08	5	22	24	17,0	18	29,0	54	32	44	14	22	19	99	WSV08SOMD	630	630	
	10	7	24	25	17,5	20	29,5	57	34	46	17	24	22	128	WSV10SOMD	630	630	
	12	8	27	29	21,5	21	30,5	59	38	47	17	27	24	168	WSV12SOMD	630	630	
	14	10	27	30	22,0	23	32,0	63	40	50	19	30	27	194	WSV14SOMD	630	630	
	16	12	30	33	24,5	24	31,5	64	43	50	24	32	30	249	WSV16SOMD	400	400	
	20	16	36	37	26,5	30	33,5	74	48	55	27	41	36	390	WSV20SOMD	400	400	
	25	20	42	42	30,0	34	35,0	81	54	59	36	46	46	618	WSV25SOMD	400	400	
	30	25	50	49	35,5	39	37,5	90	62	64	41	50	50	889	WSV30SOMD	400	400	
	38	32	60	57	41,0	43	37,0	96	72	68	50	65	60	1337	WSV38SOMD	315	315	

¹⁾ Pressione indicata = Articolo disponibile

³⁾ L = Serie leggera; ⁴⁾ S = Serie pesante

⁵⁾ Spessore minimo passaparate:.

06-18 L e 06-16 S = 3 mm

22-42 L e 20-38 S = 4 mm

PN (bar)
10 = PN (MPa)

Consegna senza dado né anello. Per informazioni sull'ordinazione di raccordi completi vedere pag. 17.

*Aggiungere i **suffixi** qui di seguito in base al materiale e alla superficie richiesti.

Suffixi codice di ordinazione		
Materiale	Suffixo superficie e materiale	Esempio
Acciaio, zincato, esente da CromoVI	CF	WSV16SOMDCF
Acciaio inossidabile	71	WSV16SOMD71
Ottone	MS	WSV18LOMDMS

EW Gomito con dado girevole

Estremità conica EO 24° / Dado girevole EO 24° DKO

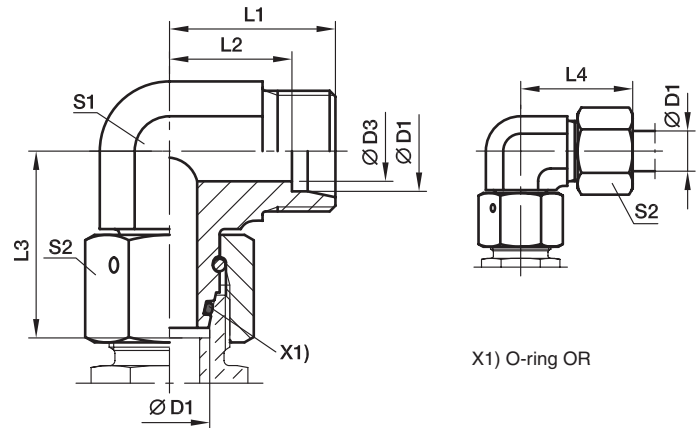

Serie	D1	D3	L1	L2	L3	L4	S1	S2	Peso g/1 pezzo	Codice di ordinazione*	PN (bar) ¹⁾	
											CF	71
L ³⁾	06	4	19	12,0	26,0	27	12	14	34	EW06LOMD	500	315
	08	6	21	14,0	27,5	29	12	17	43	EW08LOMD	500	315
	10	8	22	15,0	29,0	30	14	19	58	EW10LOMD	500	315
	12	10	24	17,0	29,5	32	17	22	81	EW12LOMD	400	315
	15	12	28	21,0	32,5	36	19	27	128	EW15LOMD	400	315
	18	15	31	23,5	35,5	40	24	32	197	EW18LOMD	400	315
	22	19	35	27,5	38,5	44	27	36	258	EW22LOMD	250	160
	28	24	38	30,5	41,5	47	36	41	370	EW28LOMD	250	160
	35	30	45	34,5	51,0	56	41	50	593	EW35LOMD	250	160
	42	36	51	40,0	56,0	63	50	60	993	EW42LOMD	250	160
S ⁴⁾	06	4	23	16,0	27,0	31	12	17	48	EW06SOMD	800	630
	08	5	24	17,0	27,5	32	14	19	65	EW08SOMD	800	630
	10	6	25	17,5	30,0	34	17	22	92	EW10SOMD	800	630
	12	8	29	21,5	31,0	38	17	24	107	EW12SOMD	630	630
	14	9	30	22,0	35,0	40	19	27	146	EW14SOMD	630	630
	16	12	33	24,5	36,5	43	24	30	212	EW16SOMD	630	400
	20	16	37	26,5	44,5	48	27	36	309	EW20SOMD	420	400
	25	20	42	30,0	50,0	54	36	46	547	EW25SOMD	420	400
	30	25	49	35,5	55,0	62	41	50	744	EW30SOMD	420	400
	38	32	57	41,0	63,0	72	50	60	1222	EW38SOMD	420	315

¹⁾ Pressione indicata = Articolo disponibile

³⁾ L = Serie leggera; ⁴⁾ S = Serie pesante

$\frac{PN \text{ (bar)}}{10} = PN \text{ (MPa)}$

Consegna senza dado né anello. Per informazioni sull'ordinazione di raccordi completi o sui materiali di tenuta alternativi vedere pag. I7.

*Aggiungere i **suffissi** qui di seguito in base al materiale e alla superficie richiesti.

Suffissi codice di ordinazione			
Materiale	Suffisso superficie e materiale	Esempio	Materiale di tenuta standard (non occorre suffisso aggiuntivo)
Acciaio, zincato, esente da CromoVI	CF	EW16SOMDCF	NBR
Acciaio inossidabile	71	EW16SOMD71	VIT

EV Gomito a 45° con dado girevole

Estremità conica EO 24° / Dado girevole EO 24° DKO

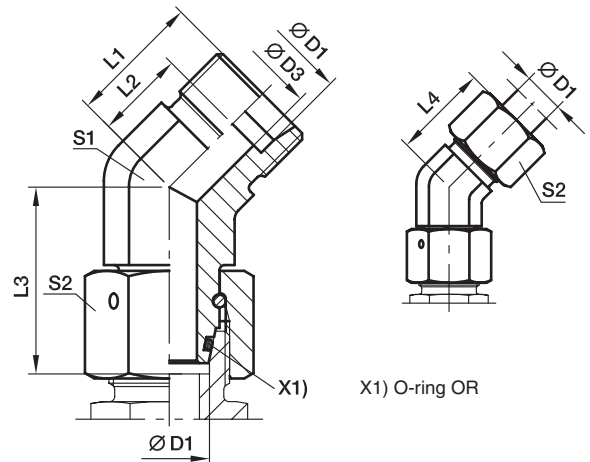

Serie	D1 	D3	L1	L2	L3	L4	S1	S2	Peso g/1 pezzo	Codice di ordinazione*	PN (bar) ¹⁾	
											CF	71
L ³⁾	06	4	16,0	9,0	26,0	24	14	14	37	EV06LOMD	315	315
	08	6	19,0	12,0	27,5	27	14	17	49	EV08LOMD	315	315
	10	8	19,0	12,0	29,0	27	19	19	77	EV10LOMD	315	315
	12	10	21,0	14,0	29,5	29	19	22	86	EV12LOMD	315	315
	15	12	24,0	17,0	32,5	32	22	27	144	EV15LOMD	315	315
	18	15	24,0	16,5	35,5	33	27	32	210	EV18LOMD	315	315
	22	19	26,0	18,5	38,5	35	30	36	270	EV22LOMD	160	160
	28	24	30,5	23,0	41,5	40	36	41	385	EV28LOMD	160	160
	35	30	37,0	26,5	51,0	48	50	50	805	EV35LOMD	160	160
	42	36	37,0	26,0	56,0	49	50	60	887	EV42LOMD	160	160
S ⁴⁾	06	4	16,0	9,0	27,0	24	14	17	50	EV06SOMD	630	630
	08	5	19,0	12,0	27,5	27	19	19	80	EV08SOMD	630	630
	10	7	21,0	13,5	30,0	30	19	22	95	EV10SOMD	630	630
	12	8	24,0	16,5	31,0	33	22	24	137	EV12SOMD	630	630
	16	12	24,0	15,5	36,5	34	27	30	217	EV16SOMD	400	400
	20	16	26,5	16,0	44,5	38	30	36	313	EV20SOMD	400	400
	25	20	30,5	18,5	50,0	43	36	46	529	EV25SOMD	400	400
	30	25	37,0	23,5	55,0	50	50	50	940	EV30SOMD	400	400
	38	32	37,0	21,0	63,0	52	50	60	1055	EV38SOMD	315	315

¹⁾ Pressione indicata = Articolo disponibile

³⁾ L = Serie leggera; ⁴⁾ S = Serie pesante

$$\frac{PN \text{ (bar)}}{10} = PN \text{ (MPa)}$$

Consegna senza dado né anello. Per informazioni sull'ordinazione di raccordi completi o sui materiali di tenuta alternativi vedere pag. I7.

Suffissi codice di ordinazione			
Materiale	Suffisso superficie e materiale	Esempio	Materiale di tenuta standard (non occorre suffisso aggiuntivo)
Acciaio, zincato, esente da CromoVI	CF	EV16SOMDCF	NBR
Acciaio inossidabile	71	EV16SOMD71	VIT

*Aggiungere i suffissi qui di seguito in base al materiale e alla superficie richiesti.

ET T di linea con dado girevole

Estremità conica EO 24° / Dado girevole EO 24° DKO

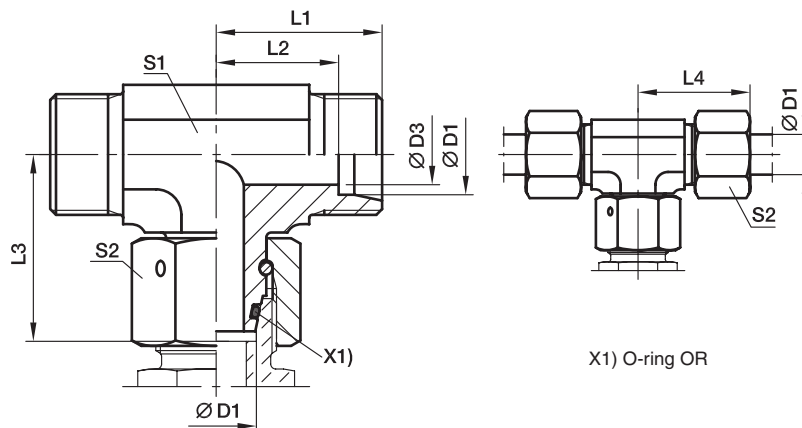

Serie	D1	D3	L1	L2	L3	L4	S1	S2	Peso g/1 pezzo	Codice di ordinazione*	PN (bar) ¹⁾	
											CF	71
L ³⁾	06	4	19	12,0	26,0	27	12	14	42	ET06LOMD	500	315
	08	6	21	14,0	27,5	29	12	17	53	ET08LOMD	500	315
	10	8	22	15,0	29,0	30	14	19	71	ET10LOMD	500	315
	12	10	24	17,0	29,5	32	17	22	97	ET12LOMD	400	315
	15	12	28	21,0	32,5	36	19	27	159	ET15LOMD	400	315
	18	15	31	23,5	35,5	40	24	32	239	ET18LOMD	400	315
	22	19	35	27,5	38,5	44	27	36	308	ET22LOMD	250	160
	28	24	38	30,5	41,5	47	36	41	449	ET28LOMD	250	160
	35	30	45	34,5	51,0	56	41	50	679	ET35LOMD	250	160
	42	36	51	40,0	56,0	63	50	60	1131	ET42LOMD	250	160
S ⁴⁾	06	4	23	16,0	27,0	31	12	17	63	ET06SOMD	800	630
	08	5	24	17,0	27,5	32	14	19	79	ET08SOMD	800	630
	10	6	25	17,5	30,0	34	17	22	113	ET10SOMD	800	630
	12	8	29	21,5	31,0	38	17	24	136	ET12SOMD	630	630
	14	9	30	22,0	35,0	40	19	27	173	ET14SOMD	630	630
	16	12	33	24,5	36,5	43	24	30	239	ET16SOMD	630	400
	20	16	37	26,5	44,5	48	27	36	388	ET20SOMD	420	400
	25	20	42	30,0	50,0	54	36	46	652	ET25SOMD	420	400
	30	25	49	35,5	55,0	62	41	50	905	ET30SOMD	420	400
	38	32	57	41,0	63,0	72	50	60	1462	ET38SOMD	420	315

1) Pressione indicata = Articolo disponibile

3) L = Serie leggera; 4) S = Serie pesante

$$\frac{PN \text{ (bar)}}{10} = PN \text{ (MPa)}$$

Consegna senza dado né anello. Per informazioni sull'ordinazione di raccordi completi o sui materiali di tenuta alternativi vedere pag. I7.

Suffissi codice di ordinazione			
Materiale	Suffisso superficie e materiale	Esempio	Materiale di tenuta standard (non occorre suffisso aggiuntivo)
Acciaio, zincato, esente da CromoVI	CF	ET16SOMDCF	NBR
Acciaio inossidabile	71	ET16SOMD71	VIT

*Aggiungere i suffissi qui di seguito in base al materiale e alla superficie richiesti.

EL T di derivazione con dado girevole

Estremità conica EO 24° / Dado girevole EO 24° DKO

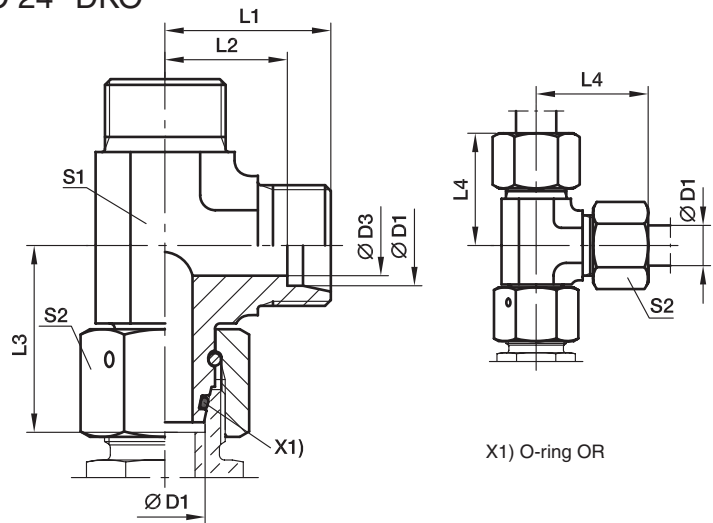

Serie	D1	D3	L1	L2	L3	L4	S1	S2	Peso g/1 pezzo	Codice di ordinazione*	PN (bar) ¹⁾		
											CF	71	
L ³⁾	06	4	19	12,0	26,0	27	12	14	44	EL06LOMD	500	315	
	08	6	21	14,0	27,5	29	12	17	53	EL08LOMD	500	315	
	10	8	22	15,0	29,0	30	14	19	68	EL10LOMD	500	315	
	12	10	24	17,0	29,5	32	17	22	95	EL12LOMD	400	315	
	15	12	28	21,0	32,5	36	19	27	151	EL15LOMD	400	315	
	18	15	31	23,5	35,5	40	24	32	233	EL18LOMD	400	315	
	22	19	35	27,5	38,5	44	27	36	309	EL22LOMD	250	160	
	28	24	38	30,5	41,5	47	36	41	436	EL28LOMD	250	160	
	35	30	45	34,5	51,0	56	41	50	666	EL35LOMD	250	160	
	42	36	51	40,0	56,0	63	50	60	1163	EL42LOMD	250	160	
	S ⁴⁾	06	4	23	16,0	27,0	31	12	17	65	EL06SOMD	800	630
		08	5	24	17,0	27,5	32	14	19	84	EL08SOMD	800	630
		10	6	25	17,5	30,0	34	17	22	118	EL10SOMD	800	630
		12	8	29	21,5	31,0	38	17	24	136	EL12SOMD	630	630
14		9	30	22,0	35,0	40	19	27	173	EL14SOMD	630	630	
16		12	33	24,5	36,5	43	24	30	260	EL16SOMD	630	400	
20		16	37	26,5	44,5	48	27	36	375	EL20SOMD	420	400	
25		20	42	30,0	50,0	54	36	46	655	EL25SOMD	420	400	
30		25	49	35,5	55,0	62	41	50	906	EL30SOMD	420	400	
38		32	57	41,0	63,0	72	50	60	1472	EL38SOMD	420	315	

¹⁾ Pressione indicata = Articolo disponibile

³⁾ L = Serie leggera; ⁴⁾ S = Serie pesante

$$\frac{PN \text{ (bar)}}{10} = PN \text{ (MPa)}$$

Consegna senza dado né anello. Per informazioni sull'ordinazione di raccordi completi o sui materiali di tenuta alternativi vedere pag. I7.

Suffissi codice di ordinazione			
Materiale	Suffisso superficie e materiale	Esempio	Materiale di tenuta standard (non occorre suffisso aggiuntivo)
Acciaio, zincato, esente da CromoVI	CF	EL16SOMDCF	NBR
Acciaio inossidabile	71	EL16SOMD71	VIT

*Aggiungere i suffissi qui di seguito in base al materiale e alla superficie richiesti.

EVW Gomito per codolo

Estremità conica EO 24° / Codolo EO orientabile

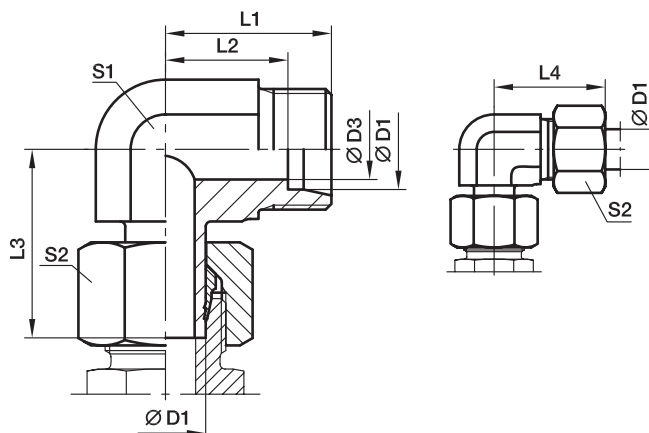

Con dado premontato e anello progressivo per la connessione.
Montaggio finale (in apposito corpo) almeno 1/4 di giro oltre il punto di resistenza chiaramente percepibile.

Serie	D1	D3	L1	L2	L3	S1	S2	S3	Peso g/1 pezzo	Codice di ordinazione*	PN (bar) ¹⁾		
											CF	71	MS
L ³⁾	06	4	19	12,0	26,0	27	12	14	32	EVW06LOMD	315	315	200
	08	6	21	14,0	27,5	29	12	17	40	EVW08LOMD	315	315	200
	10	8	22	15,0	29,0	30	14	19	54	EVW10LOMD	315	315	200
	12	10	24	17,0	29,5	32	17	22	76	EVW12LOMD	315	315	200
	15	12	28	21,0	32,5	36	19	27	119	EVW15LOMD	315	315	200
	18	15	31	23,5	35,5	40	24	32	192	EVW18LOMD	315	315	200
	22	19	35	27,5	38,5	44	27	36	355	EVW22LOMD	160	160	100
	28	24	38	30,5	42,0	47	36	41	514	EVW28LOMD	160	160	100
	35	30	45	34,5	51,0	56	41	50	536	EVW35LOMD	160	160	100
	42	36	51	40,0	60,0	63	50	60	977	EVW42LOMD	160	160	100
S ⁴⁾	06	4	23	16,0	27,0	31	12	17	44	EVW06SOMD	630	630	400
	08	5	24	17,0	27,5	32	14	19	63	EVW08SOMD	630	630	400
	10	7	25	17,5	31,0	34	17	22	95	EVW10SOMD	630	630	400
	12	8	29	21,5	31,0	38	17	24	110	EVW12SOMD	630	630	400
	14	10	30	22,0	35,0	40	19	27	137	EVW14SOMD	400	400	250
	16	12	33	24,5	37,5	43	24	30	211	EVW16SOMD	400	400	250
	20	16	37	26,5	44,5	48	27	36	306	EVW20SOMD	400	400	250
	25	20	42	30,0	50,0	54	36	46	558	EVW25SOMD	400	400	250
	30	25	49	35,5	55,0	62	41	50	724	EVW30SOMD	400	400	250
	38	32	57	41,0	66,5	72	50	60	1307	EVW38SOMD	315	315	200

¹⁾ Pressione indicata = Articolo disponibile

³⁾ L = Serie leggera; ⁴⁾ S = Serie pesante

$$\frac{PN \text{ (bar)}}{10} = PN \text{ (MPa)}$$

Consegna senza dado né anello. Per informazioni sull'ordinazione di raccordi completi vedere pag. 17.

*Aggiungere i suffissi qui di seguito in base al materiale e alla superficie richiesti.

Suffissi codice di ordinazione		
Materiale	Suffisso superficie e materiale	Esempio
Acciaio, zincato, esente da CromoVI	CF	EVW16SOMDCF
Acciaio inossidabile	71	EVW16SOMD71
Ottone	MS	EVW16SOMDMS

EVT T di linea per codolo

Estremità conica EO 24° / Codolo EO orientabile

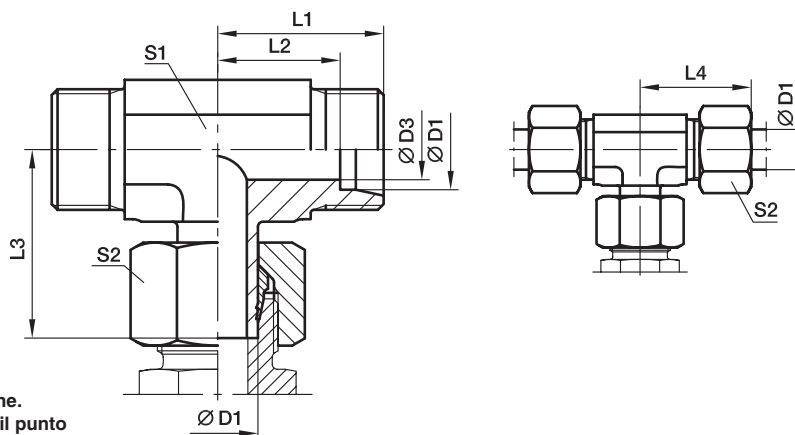

Con dado premontato e anello progressivo per la connessione.
Montaggio finale (in apposito corpo) almeno 1/4 di giro oltre il punto di resistenza chiaramente percepibile.

Serie	D1	D3	L1	L2	L3	L4	S1	S2	Peso g/1 pezzo	Codice di ordinazione*	PN (bar) ¹⁾		
											CF	71	MS
L ³⁾	06	4	19	12,0	26,0	27	12	14	37	EVT06LOMD	315	315	200
	08	6	21	14,0	27,5	29	12	17	49	EVT08LOMD	315	315	200
	10	8	22	15,0	29,0	30	14	19	66	EVT10LOMD	315	315	200
	12	10	24	17,0	30,5	32	17	22	93	EVT12LOMD	315	315	200
	15	12	28	21,0	32,5	36	19	27	146	EVT15LOMD	315	315	200
	18	15	31	23,5	35,5	40	24	32	201	EVT18LOMD	315	315	200
	22	19	35	27,5	38,5	44	27	36	274	EVT22LOMD	160	160	
	28	24	38	30,5	43,5	47	36	41	441	EVT28LOMD	160	160	
	35	30	45	34,5	54,5	56	41	50	633	EVT35LOMD	160	160	
	42	36	51	40,0	60,0	63	50	60	1129	EVT42LOMD	160	160	
S ⁴⁾	06	4	23	16,0	27,0	31	12	17	61	EVT06SOMD	630	630	
	08	5	24	17,0	29,0	32	14	19	44	EVT08SOMD	630	630	
	10	7	25	17,5	31,0	34	17	22	84	EVT10SOMD	630	630	
	12	8	29	21,5	33,0	38	17	24	131	EVT12SOMD	630	630	
	14	10	30	22,0	35,0	40	19	27	173	EVT14SOMD	400	400	
	16	12	33	24,5	37,5	43	24	30	240	EVT16SOMD	400	400	
	20	16	37	26,5	44,5	48	27	36	345	EVT20SOMD	400	400	
	25	20	42	30,0	50,5	54	36	46	647	EVT25SOMD	400	400	
	30	25	49	35,5	56,5	62	41	50	873	EVT30SOMD	400	400	
	38	32	57	41,0	66,5	72	50	60	1361	EVT38SOMD	315	315	

¹⁾ Pressione indicata = Articolo disponibile

³⁾ L = Serie leggera; ⁴⁾ S = Serie pesante

$$\frac{PN \text{ (bar)}}{10} = PN \text{ (MPa)}$$

Consegna senza dado né anello. Per informazioni sull'ordinazione di raccordi completi vedere pag. 17.

*Aggiungere i suffissi qui di seguito in base al materiale e alla superficie richiesti.

Suffissi codice di ordinazione		
Materiale	Suffisso superficie e materiale	Esempio
Acciaio, zincato, esente da CromoVI	CF	EVT16SOMDCF
Acciaio inossidabile	71	EVT16SOMD71
Ottone	MS	EVT18LOMDMS

EVL T di derivazione per codolo

Estremità conica EO 24° / Codolo EO orientabile

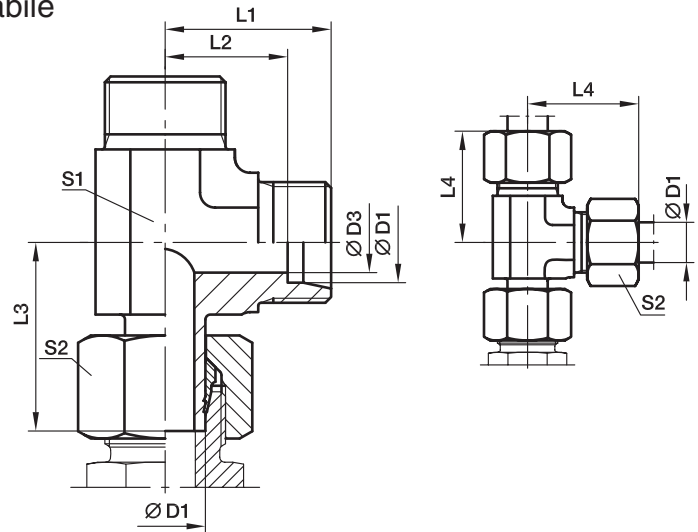

Con dado premontato e anello progressivo per la connessione.
Montaggio finale (in apposito corpo) almeno 1/4 di giro oltre il punto di resistenza chiaramente percepibile.

Serie	D1	D3	L1	L2	L3	L4	S1	S2	Peso g/1 pezzo	Codice di ordinazione*	PN (bar) ¹⁾		
											CF	71	MS
L ³⁾	06	4	19	12,0	26,0	27	12	14	40	EVL06LOMD	315	315	200
	08	6	21	14,0	27,5	29	12	17	50	EVL08LOMD	315	315	200
	10	8	22	15,0	29,0	30	14	19	64	EVL10LOMD	315	315	200
	12	10	24	17,0	30,5	32	17	22	93	EVL12LOMD	315	315	200
	15	12	28	21,0	32,5	36	19	27	147	EVL15LOMD	315	315	200
	18	15	31	23,5	35,5	40	24	32	229	EVL18LOMD	315	315	200
	22	19	35	27,5	39,0	44	27	36	296	EVL22LOMD	160	160	
	28	24	38	30,5	43,5	47	36	41	416	EVL28LOMD	160	160	
	35	30	45	34,5	54,5	56	41	50	661	EVL35LOMD	160	160	
	42	36	51	40,0	60,0	63	50	60	1105	EVL42LOMD	160	160	
S ⁴⁾	06	4	23	16,0	27,0	31	12	17	57	EVL06SOMD	630	630	
	08	5	24	17,0	29,0	32	14	19	84	EVL08SOMD	630	630	
	10	7	25	17,5	32,0	34	17	22	116	EVL10SOMD	630	630	
	12	8	29	21,5	33,0	38	17	24	137	EVL12SOMD	630	630	
	14	10	30	22,0	35,0	40	19	27	175	EVL14SOMD	400	400	
	16	12	33	24,5	37,5	43	24	30	259	EVL16SOMD	400	400	
	20	16	37	26,5	44,5	48	27	36	371	EVL20SOMD	400	400	
	25	20	42	30,0	50,5	54	36	46	647	EVL25SOMD	400	400	
	30	25	49	35,5	56,5	62	41	50	906	EVL30SOMD	400	400	
	38	32	57	41,0	66,5	72	50	60	1549	EVL38SOMD	315	315	

¹⁾ Pressione indicata = Articolo disponibile

³⁾ L = Serie leggera; ⁴⁾ S = Serie pesante

$$\frac{PN \text{ (bar)}}{10} = PN \text{ (MPa)}$$

Consegna senza dado né anello. Per informazioni sull'ordinazione di raccordi completi vedere pag. 17.

*Aggiungere i **suffissi** qui di seguito in base al materiale e alla superficie richiesti.

Suffissi codice di ordinazione		
Materiale	Suffisso superficie e materiale	Esempio
Acciaio, zincato, esente da CromoVI	CF	EVL16SOMDCF
Acciaio inossidabile	71	EVL16SOMD71
Ottone	MS	EVL18LOMDMS

DA Adattatore distanziale

Dado girevole EO 24° DKO / Estremità conica EO 24°

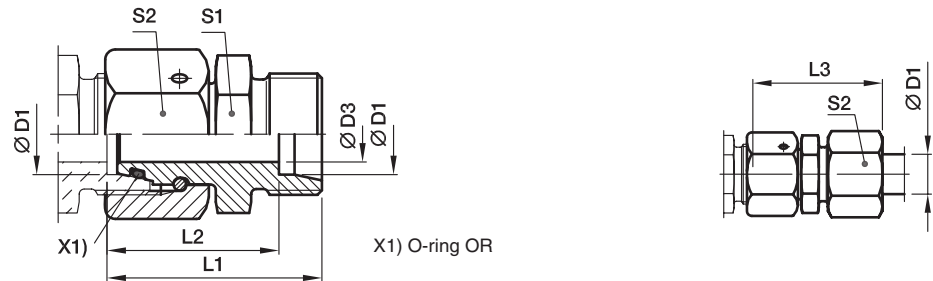

Serie	D1	D3	L1	L2	L3	S1	S2	Peso g/1 pezzo	Codice di ordinazione*	PN (bar) ¹⁾		
										CF	71	MS
L ³⁾	06	2,5	43,0	36	51	12	14	33	DA06LOMD	500	315	200
	08	4,0	43,0	36	51	14	17	46	DA08LOMD	500	315	200
	10	6,0	43,0	36	51	17	19	60	DA10LOMD	500	315	200
	12	8,0	43,0	36	51	19	22	75	DA12LOMD	400	315	200
	15	10,0	43,0	36	51	24	27	118	DA15LOMD	400	315	200
	18	13,0	43,5	36	52	27	32	153	DA18LOMD	400	315	200
	22	17,0	47,5	40	56	32	36	210	DA22LOMD	250	160	100
	28	22,0	47,5	40	57	41	41	279	DA28LOMD	250	160	100
	35	28,0	60,5	50	72	46	50	468	DA35LOMD	250	160	100
	42	34,0	71,0	60	83	55	60	802	DA42LOMD	250	160	100
S ⁴⁾	06	2,5	43,0	36	51	14	17	48	DA06SOMD	800	630	400
	08	4,0	43,0	36	51	17	19	64	DA08SOMD	800	630	400
	10	6,0	43,5	36	52	19	22	81	DA10SOMD	800	630	400
	12	8,0	43,5	36	52	22	24	97	DA12SOMD	630	630	400
	14	9,0	48,0	40	58	24	27	133	DA14SOMD	630	630	400
	16	11,0	48,5	40	58	27	30	166	DA16SOMD	630	400	250
	20	14,0	56,5	46	68	32	36	265	DA20SOMD	420	400	250
	25	18,0	62,0	50	74	41	46	466	DA25SOMD	420	400	250
	30	23,0	69,5	56	83	46	50	601	DA30SOMD	420	400	250
	38	30,0	76,0	60	91	55	60	871	DA38SOMD	420	315	200

¹⁾ Pressione indicata = Articolo disponibile

³⁾ L = Serie leggera; ⁴⁾ S = Serie pesante

$$\frac{\text{PN (bar)}}{10} = \text{PN (MPa)}$$

Consegna senza dado né anello. Per informazioni sull'ordinazione di raccordi completi o sui materiali di tenuta alternativi vedere pag. I7.

*Aggiungere i **suffissi** qui di seguito in base al materiale e alla superficie richiesti.

Suffissi codice di ordinazione			
Materiale	Suffisso superficie e materiale	Esempio	Materiale di tenuta standard (non occorre suffisso aggiuntivo)
Acciaio, zincato, esente da CromoVI	CF	DA16SOMDCF	NBR
Acciaio inossidabile	71	DA16SOMD71	VIT
Ottone	MS	DA16SOMDMS	NBR

RED Raccordo riduzione tubo

Dado girevole EO 24° DKO / Estremità conica EO 24°

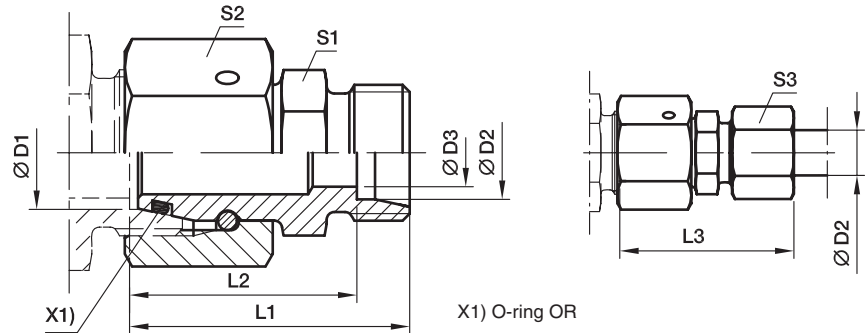

Serie 2) 3) 4)	D1	D2	D3	L1	L2	L3	S1	S2	S3	Peso g/1 pezzo	Codice di ordinazione*	PN (bar) ¹⁾	
												CF	71
L/LL	06	04	2,5	28,5	24,5	34,0	9	14	10	17	RED06L/04LLOMD	100	100
L	08	06	4,0	30,5	23,5	38,0	12	17	14	29	RED08/06LOMD	500	315
L	10	06	4,0	32,0	25,0	40,0	14	19	14	36	RED10/06LOMD	500	315
L	10	08	6,0	32,0	25,0	40,0	14	19	17	38	RED10/08LOMD	500	315
L	12	06	4,0	32,0	25,0	40,0	17	22	14	49	RED12/06LOMD	400	315
L	12	08	6,0	32,0	25,0	40,0	17	22	17	49	RED12/08LOMD	400	315
L	12	10	8,0	33,0	26,0	41,0	17	22	19	51	RED12/10LOMD	400	315
L	15	06	4,0	35,5	28,5	43,0	19	27	14	81	RED15/06LOMD	400	315
L	15	08	6,0	35,5	28,5	43,0	19	27	17	85	RED15/08LOMD	400	315
L	15	10	8,0	36,5	29,5	44,0	19	27	19	83	RED15/10LOMD	400	315
L	15	12	10,0	36,5	29,5	44,0	19	27	22	83	RED15/12LOMD	400	315
L	18	06	4,0	35,0	28,0	43,0	24	32	14	109	RED18/06LOMD	400	315
L	18	08	6,0	35,0	28,0	43,0	24	32	17	111	RED18/08LOMD	400	315
L	18	10	8,0	36,0	29,0	44,0	24	32	19	110	RED18/10LOMD	400	315
L	18	12	10,0	36,0	29,0	44,0	24	32	22	110	RED18/12LOMD	400	315
L	18	15	12,0	37,0	30,0	45,0	24	32	27	115	RED18/15LOMD	400	315
L/S	18	16	12,0	40,0	31,5	49,5	27	32	30	138	RED18L/16SOMD	400	315
L	22	06	4,0	39,0	32,0	47,0	27	36	14	158	RED22/06LOMD	250	160
L	22	08	6,0	39,0	32,0	47,0	27	36	17	158	RED22/08LOMD	250	160
L	22	10	8,0	40,0	33,0	48,0	27	36	19	159	RED22/10LOMD	250	160
L	22	12	10,0	40,0	33,0	48,0	27	36	22	157	RED22/12LOMD	250	160
L	22	15	12,0	41,0	34,0	49,0	27	36	27	164	RED22/15LOMD	250	160
L/S	22	16	12,0	43,0	34,5	52,5	27	36	30	173	RED22L/16SOMD	250	160
L	22	18	15,0	41,0	33,5	50,0	27	36	32	167	RED22/18LOMD	250	160
L/S	22	20	16,0	45,0	34,5	56,0	32	36	36	203	RED22L/20SOMD	250	160
L	28	06	4,0	41,0	34,0	49,0	32	41	14	219	RED28/06LOMD	250	160
L	28	08	6,0	41,0	34,0	49,0	32	41	17	221	RED28/08LOMD	250	160
L	28	10	8,0	42,0	35,0	50,0	32	41	19	213	RED28/10LOMD	250	160
L	28	12	10,0	42,0	35,0	50,0	32	41	22	213	RED28/12LOMD	250	160
L	28	15	12,0	43,0	36,0	51,0	32	41	27	218	RED28/15LOMD	250	160
L/S	28	16	12,0	45,0	36,5	54,5	32	41	30	227	RED28L/16SOMD	250	160
L	28	18	15,0	43,0	35,5	52,0	32	41	32	220	RED28/18LOMD	250	160
L	28	22	19,0	45,0	37,5	54,0	32	41	36	222	RED28/22LOMD	250	160
L/S	28	25	20,0	50,0	38,0	62,0	41	41	46	300	RED28L/25SOMD	250	160
L	35	06	4,0	44,0	37,0	52,0	41	50	14	318	RED35/06LOMD	250	160
L	35	08	6,0	44,0	37,0	52,0	41	50	17	318	RED35/08LOMD	250	160
L	35	10	8,0	45,0	38,0	53,0	41	50	19	318	RED35/10LOMD	250	160
L	35	12	10,0	45,0	38,0	53,0	41	50	22	324	RED35/12LOMD	250	160
L	35	15	12,0	46,0	39,0	54,0	41	50	27	328	RED35/15LOMD	250	160
L	35	18	15,0	46,0	38,5	55,0	41	50	32	328	RED35/18LOMD	250	160
L	35	22	19,0	48,0	40,5	57,0	41	50	36	331	RED35/22LOMD	250	160

RED Raccordo riduzione tubo

Dado girevole EO 24° DKO / Estremità conica EO 24°

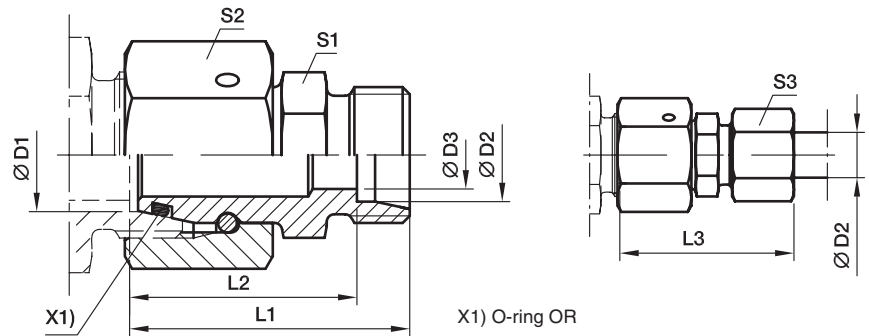

Serie 2) 3) 4)	D1	D2	D3	L1	L2	L3	S1	S2	S3	Peso g/1 pezzo	Codice di ordinazione*	PN (bar) ¹⁾	
												CF	71
L/S	35	25	20,0	52,0	40,0	64,0	41	50	46	366	RED35L/25SOMD	250	160
L	35	28	24,0	48,0	40,5	57,0	41	50	41	327	RED35/28LOMD	250	160
L/S	35	30	25,0	55,0	41,5	68,0	46	50	50	435	RED35L/30SOMD	250	160
L	42	10	8,0	48,5	41,5	56,0	50	60	19	537	RED42/10LOMD	250	160
L	42	12	10,0	48,5	41,5	56,0	50	60	22	538	RED42/12LOMD	250	160
L	42	15	12,0	49,5	42,5	58,0	50	60	27	534	RED42/15LOMD	250	160
L	42	18	15,0	49,5	42,0	58,0	50	60	32	544	RED42/18LOMD	250	160
L	42	22	19,0	51,5	44,0	60,0	50	60	36	543	RED42/22LOMD	250	160
L	42	28	24,0	51,5	44,0	61,0	50	60	41	539	RED42/28LOMD	250	160
L/S	42	30	25,0	57,5	44,0	70,5	50	60	50	588	RED42L/30SOMD	250	160
L	42	35	30,0	53,5	43,0	65,0	50	60	50	541	RED42/35LOMD	250	160
L/S	42	38	32,0	61,5	45,5	76,0	55	60	60	701	RED42L/38SOMD	250	160

1) Pressione indicata = Articolo disponibile

2) LL = Serie ultraleggera; 3) L = Serie leggera; 4) S = Serie pesante

$$\frac{PN \text{ (bar)}}{10} = PN \text{ (MPa)}$$

Consegna senza dado né anello. Per informazioni sull'ordinazione di raccordi completi o sui materiali di tenuta alternativi vedere pag. I7.

Suffissi codice di ordinazione			
Materiale	Suffisso superficie e materiale	Esempio	Materiale di tenuta standard (non occorre suffisso aggiuntivo)
Acciaio, zincato, esente da CromoVI	CF	RED18/15LOMDCF	NBR
Acciaio inossidabile	71	RED18/15LOMD71	VIT

*Aggiungere i suffissi qui di seguito in base al materiale e alla superficie richiesti.

RED Raccordo riduzione tubo

Dado girevole EO 24° DKO / Estremità conica EO 24°

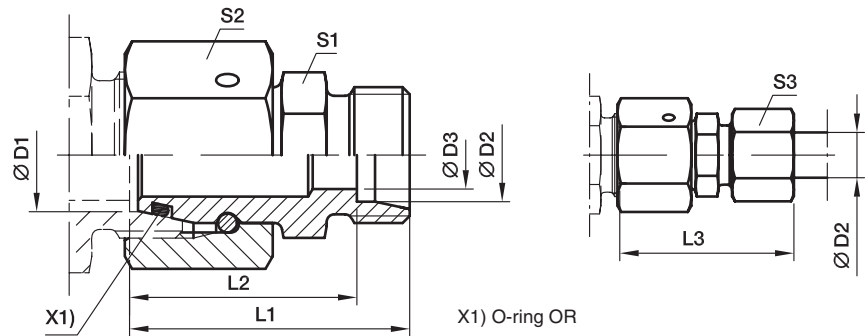

Serie ^{3) 4)}	D1	D2	D3	L1	L2	L3	S1	S2	S3	Peso g/1 pezzo	Codice di ordinazione*	PN (bar) ¹⁾	
												CF	71
S	08	06	4	34,0	27,0	42	14	19	17	42	RED08/06SOMD	800	630
S	10	06	4	34,5	27,5	42	17	22	17	55	RED10/06SOMD	800	630
S	10	08	5	34,5	27,5	42	17	22	19	58	RED10/08SOMD	800	630
S	12	06	4	36,0	29,0	44	17	24	17	66	RED12/06SOMD	630	630
S	12	08	5	36,0	29,0	44	17	24	19	68	RED12/08SOMD	630	630
S	12	10	7	37,0	29,5	46	19	24	22	75	RED12/10SOMD	630	630
S	14	06	4	38,5	31,5	46	19	27	17	88	RED14/06SOMD	630	630
S	14	08	5	38,5	31,5	46	19	27	19	90	RED14/08SOMD	630	630
S	14	10	7	38,5	31,0	47	19	27	22	91	RED14/10SOMD	630	630
S	14	12	8	38,5	31,0	47	22	27	24	100	RED14/12SOMD	630	630
S	16	06	4	39,0	32,0	47	22	30	17	112	RED16/06SOMD	630	400
S	16	08	5	39,0	32,0	47	22	30	19	114	RED16/08SOMD	630	400
S	16	10	7	39,0	31,5	48	22	30	22	115	RED16/10SOMD	630	400
S	16	12	8	39,0	31,5	48	22	30	24	118	RED16/12SOMD	630	400
S	16	14	10	41,0	33,0	51	24	30	27	128	RED16/14SOMD	630	400
S/L	16	15	11	39,0	32,0	47	24	30	27	120	RED16S/15LOMD	400	315
S	20	06	4	43,0	36,0	51	27	36	17	172	RED20/06SOMD	420	400
S	20	08	5	43,0	36,0	51	27	36	19	174	RED20/08SOMD	420	400
S	20	10	7	43,0	35,5	52	27	36	22	174	RED20/10SOMD	420	400
S	20	12	8	43,0	35,5	52	27	36	24	177	RED20/12SOMD	420	400
S	20	14	10	45,0	37,0	55	27	36	27	182	RED20/14SOMD	420	400
S/L	20	15	12	43,0	36,0	51	27	36	27	173	RED20S/15LOMD	400	315
S	20	16	12	45,0	36,5	55	27	36	30	182	RED20/16SOMD	420	400
S/L	20	18	14	43,0	35,5	51	27	36	32	178	RED20S/18LOMD	400	315
S	25	06	4	45,5	38,5	53	32	46	17	294	RED25/06SOMD	420	400
S	25	08	5	45,5	38,5	53	32	46	19	295	RED25/08SOMD	420	400
S	25	10	7	45,5	38,0	54	32	46	22	296	RED25/10SOMD	420	400
S	25	12	8	45,5	38,0	54	32	46	24	299	RED25/12SOMD	420	400
S	25	14	10	47,5	39,5	57	32	46	27	303	RED25/14SOMD	420	400
S	25	16	12	47,5	39,0	57	32	46	30	304	RED25/16SOMD	420	400
S/L	25	18	15	45,5	38,0	54	32	46	32	299	RED25S/18LOMD	400	315
S	25	20	16	49,5	39,0	61	32	46	36	315	RED25/20SOMD	420	400
S/L	25	22	18	47,5	40,0	56	32	46	36	304	RED25S/22LOMD	250	160
S	30	06	4	51,0	44,0	59	41	50	17	412	RED30/06SOMD	420	400
S	30	08	5	51,0	44,0	59	41	50	19	404	RED30/08SOMD	420	400
S	30	10	7	51,0	43,5	60	41	50	22	405	RED30/10SOMD	420	400
S	30	12	8	51,0	43,5	60	41	50	24	405	RED30/12SOMD	420	400
S	30	14	10	53,0	45,0	63	41	50	27	408	RED30/14SOMD	420	400
S	30	16	12	53,0	44,5	63	41	50	30	412	RED30/16SOMD	420	400
S	30	20	16	55,0	44,5	66	41	50	36	421	RED30/20SOMD	420	400

RED Raccordo riduzione tubo

Dado girevole EO 24° DKO / Estremità conica EO 24°

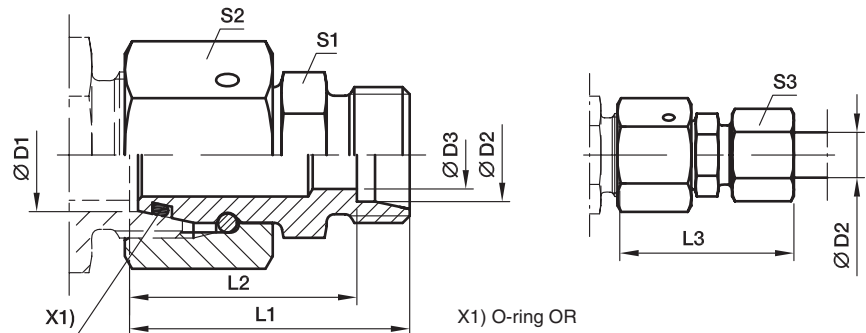

Serie 3) 4)	D1	D2	D3	L1	L2	L3	S1	S2	S3	Peso g/1 pezzo	Codice di ordinazione*	PN (bar) ¹⁾	
												CF	71
S/L	30	22	19	53,0	45,5	61	41	50	36	406	RED30S/22LOMD	250	160
S	30	25	20	57,0	45,0	69	41	50	46	439	RED30/25SOMD	420	400
S/L	30	28	23	53,0	45,5	62	41	50	41	406	RED30S/28LOMD	250	160
S	38	06	4	54,5	47,5	62	50	60	17	556	RED38/06SOMD	420	315
S	38	08	5	54,5	47,5	62	50	60	19	581	RED38/08SOMD	420	315
S	38	10	7	54,5	47,0	63	50	60	22	579	RED38/10SOMD	420	315
S	38	12	8	54,5	47,0	63	50	60	24	577	RED38/12SOMD	420	315
S	38	14	10	56,5	48,5	66	50	60	27	579	RED38/14SOMD	420	315
S	38	16	12	56,5	48,0	66	50	60	30	580	RED38/16SOMD	420	315
S	38	20	16	58,5	48,0	70	50	60	36	601	RED38/20SOMD	420	315
S	38	25	20	60,5	48,5	73	50	60	46	615	RED38/25SOMD	420	315
S/L	38	28	24	56,5	49,0	65	50	60	41	573	RED38S/28LOMD	250	160
S	38	30	25	62,5	49,0	76	50	60	50	625	RED38/30SOMD	420	315
S/L	38	35	30	58,5	48,0	69	50	60	50	588	RED38S/35LOMD	250	160

1) Pressione indicata = Articolo disponibile

3) L = Serie leggera; 4) S = Serie pesante

$$\frac{PN \text{ (bar)}}{10} = PN \text{ (MPa)}$$

Consegna senza dado né anello. Per informazioni sull'ordinazione di raccordi completi o sui materiali di tenuta alternativi vedere pag. I7.

Suffissi codice di ordinazione			
Materiale	Suffisso superficie e materiale	Esempio	Materiale di tenuta standard (non occorre suffisso aggiuntivo)
Acciaio, zincato, esente da CromoVI	CF	RED16/12SOMDCF	NBR
Acciaio inossidabile	71	RED16/12SOMD71	VIT

*Aggiungere i suffissi qui di seguito in base al materiale e alla superficie richiesti.

KOR Raccordo riduzione tubo – Acciaio e ottone

Codolo EO orientabile / Estremità conica EO 24°

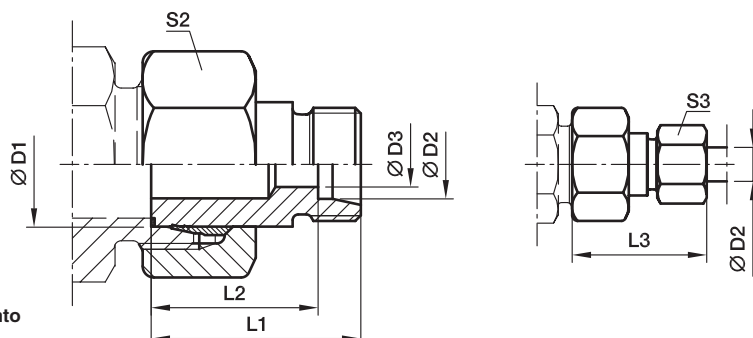

Con dado premontato e anello progressivo per la connessione.
Montaggio finale (in apposito corpo) almeno 1/4 di giro oltre il punto di resistenza chiaramente percepibile.

Serie 2) 3)	D1	D2	D3	L1	L2	L3	S2	S3	Peso g/1 pezzo	Codice di ordinazione*	PN (bar) ¹⁾	
											CF	MS
LL	06	04	3,0	28,5	24,5	34	12	10	16	KOR06/04LLOMD	100	
LL	08	04	3,0	28,5	24,5	34	14	10	16	KOR08/04LLOMD	100	
LL	08	06	4,5	23,0	17,5	29	14	12	14	KOR08/06LLOMD	100	
L/LL	06	04	3,0	28,5	24,5	34	14	10	16	KOR06L/04LLOMD	100	
L/LL	08	04	3,0	28,5	24,5	34	17	10	16	KOR08L/04LLOMD	100	
L	08	06	4,0	30,5	23,5	38	17	14	27	KOR08/06LOMD	315	200
L/LL	10	04	3,0	28,5	24,5	34	19	10	32	KOR10L/04LLOMD	100	
L	10	06	4,0	30,5	23,5	38	19	14	34	KOR10/06LOMD	315	200
L	10	08	6,0	30,5	23,5	38	19	17	35	KOR10/08LOMD	315	200
L/LL	12	04	3,0	28,5	24,5	34	22	10	41	KOR12L/04LLOMD	100	
L	12	06	4,0	30,5	23,5	38	22	14	45	KOR12/06LOMD	315	200
L	12	08	6,0	30,5	23,5	38	22	17	45	KOR12/08LOMD	315	200
L	12	10	8,0	31,5	24,5	39	22	19	46	KOR12/10LOMD	315	200
L	15	06	4,0	30,5	23,5	38	27	14	68	KOR15/06LOMD	315	200
L	15	08	6,0	30,5	23,5	38	27	17	69	KOR15/08LOMD	315	200
L	15	10	8,0	31,5	24,5	39	27	19	70	KOR15/10LOMD	315	200
L	15	12	10,0	31,5	24,5	39	27	22	70	KOR15/12LOMD	315	200
L	18	06	4,0	31,5	24,5	39	32	14	100	KOR18/06LOMD	315	200
L	18	08	6,0	31,5	24,5	39	32	17	102	KOR18/08LOMD	315	200
L	18	10	8,0	32,5	25,5	40	32	19	102	KOR18/10LOMD	315	200
L	18	12	10,0	32,5	25,5	40	32	22	101	KOR18/12LOMD	315	200
L	18	15	12,0	33,5	26,5	42	32	27	106	KOR18/15LOMD	315	200
L	22	06	4,0	32,5	25,5	40	36	14	137	KOR22/06LOMD	160	100
L	22	08	6,0	32,5	25,5	40	36	17	136	KOR22/08LOMD	160	100
L	22	10	8,0	33,5	26,5	41	36	19	138	KOR22/10LOMD	160	100
L	22	12	10,0	33,5	26,5	41	36	22	138	KOR22/12LOMD	160	100
L	22	15	12,0	34,5	27,5	43	36	27	143	KOR22/15LOMD	160	100
L	22	18	15,0	34,5	27,0	43	36	32	143	KOR22/18LOMD	160	100
L	28	06	4,0	33,5	26,5	41	41	14	177	KOR28/06LOMD	160	100
L	28	08	6,0	33,5	26,5	41	41	17	179	KOR28/08LOMD	160	100
L	28	10	8,0	34,5	27,5	42	41	19	180	KOR28/10LOMD	160	100
L	28	12	10,0	34,5	27,5	42	41	22	180	KOR28/12LOMD	160	100
L	28	15	12,0	35,5	28,5	44	41	27	185	KOR28/15LOMD	160	100
L	28	18	15,0	35,5	28,0	44	41	32	184	KOR28/18LOMD	160	100
L	28	22	19,0	37,5	30,0	46	41	36	188	KOR28/22LOMD	160	100
L	35	06	4,0	38,5	31,5	46	50	14	302	KOR35/06LOMD	160	
L	35	08	6,0	38,5	31,5	46	50	17	306	KOR35/08LOMD	160	
L	35	10	8,0	39,5	32,5	47	50	19	305	KOR35/10LOMD	160	100
L	35	12	10,0	39,5	32,5	47	50	22	304	KOR35/12LOMD	160	100
L	35	15	12,0	40,5	33,5	49	50	27	308	KOR35/15LOMD	160	100
L	35	18	15,0	40,5	33,0	49	50	32	316	KOR35/18LOMD	160	100
L	35	22	19,0	42,5	35,0	51	50	36	310	KOR35/22LOMD	160	100
L	35	28	24,0	42,5	35,0	52	50	41	305	KOR35/28LOMD	160	100

KOR Raccordo riduzione tubo – Acciaio e ottone

Codolo EO orientabile / Estremità conica EO 24°

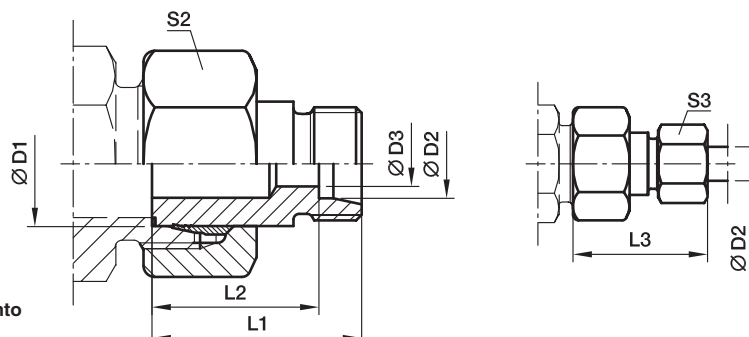

Con dado premontato e anello progressivo per la connessione.
Montaggio finale (in apposito corpo) almeno 1/4 di giro oltre il punto di resistenza chiaramente percepibile.

Serie ^{2) 3)}	D1 	D2 	D3	L1	L2	L3	S2	S3	Peso g/1 pezzo	Codice di ordinazione*	PN (bar) ¹⁾	
											CF	MS
L	42	10	8,0	40,5	33,5	48	60	19	455	KOR42/10LOMD	160	
L	42	12	10,0	40,5	33,5	48	60	22	438	KOR42/12LOMD	160	
L	42	15	12,0	41,5	34,5	50	60	27	438	KOR42/15LOMD	160	100
L	42	18	15,0	41,5	34,0	50	60	32	449	KOR42/18LOMD	160	100
L	42	22	19,0	43,5	36,0	52	60	36	461	KOR42/22LOMD	160	100
L	42	28	24,0	43,5	36,0	53	60	41	443	KOR42/28LOMD	160	100
L	42	35	30,0	45,5	35,0	57	60	50	444	KOR42/35LOMD	160	100

¹⁾ Pressione indicata = Articolo disponibile

²⁾ LL = Serie ultraleggera; ³⁾ L = Serie leggera

$\frac{PN \text{ (bar)}}{10} = PN \text{ (MPa)}$

Consegna senza dado né anello. Per informazioni sull'ordinazione di raccordi completi vedere pag. 17.

*Aggiungere i **suffissi** qui di seguito in base al materiale e alla superficie richiesti.

Suffissi codice di ordinazione		
Materiale	Suffisso superficie e materiale	Esempio
Acciaio, zincato, esente da CromoVI	CF	KOR18/15LOMDCF
Ottone	MS	KOR18/15LOMDMS

KOR Raccordo riduzione tubo – Acciaio e ottone

Codolo EO orientabile / Estremità conica EO 24°

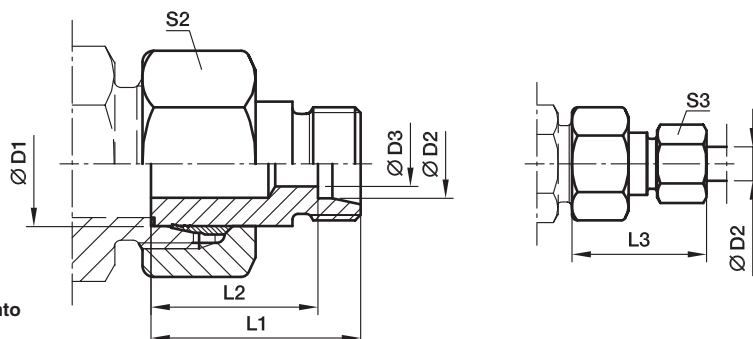

Con dado premontato e anello progressivo per la connessione.
Montaggio finale (in apposito corpo) almeno 1/4 di giro oltre il punto di resistenza chiaramente percepibile.

Serie	D1	D2	D3	L1	L2	L3	S2	S3	Peso g/1 pezzo	Codice di ordinazione*	PN (bar) ¹⁾	
											CF	MS
S ⁴⁾	08	06	4	32	25,0	40	19	17	37	KOR08/06SOMD	630	400
	10	06	4	33	26,0	41	22	17	53	KOR10/06SOMD	630	400
	10	08	5	33	26,0	41	22	19	55	KOR10/08SOMD	630	400
	12	06	4	34	27,0	42	24	17	61	KOR12/06SOMD	630	400
	12	08	5	34	27,0	42	24	19	63	KOR12/08SOMD	630	400
	12	10	7	34	26,5	43	24	22	64	KOR12/10SOMD	630	400
	14	06	4	36	29,0	44	27	17	88	KOR14/06SOMD	630	400
	14	08	5	36	29,0	44	27	19	89	KOR14/08SOMD	630	400
	14	10	7	36	28,5	45	27	22	91	KOR14/10SOMD	630	400
	14	12	8	36	28,5	45	27	24	92	KOR14/12SOMD	630	400
	16	06	4	36	29,0	44	30	17	106	KOR16/06SOMD	400	250
	16	08	5	36	29,0	44	30	19	108	KOR16/08SOMD	400	250
	16	10	7	36	28,5	45	30	22	114	KOR16/10SOMD	400	250
	16	12	8	36	28,5	45	30	24	115	KOR16/12SOMD	400	250
	16	14	10	38	30,0	48	30	27	116	KOR16/14SOMD	400	250
	20	06	4	41	34,0	49	36	17	175	KOR20/06SOMD	400	250
20	08	5	41	34,0	49	36	19	177	KOR20/08SOMD	400	250	
20	10	7	41	33,5	50	36	22	178	KOR20/10SOMD	400	250	
20	12	8	41	33,5	50	36	24	180	KOR20/12SOMD	400	250	
20	14	10	41	33,0	51	36	27	180	KOR20/14SOMD	400	250	
20	16	12	43	34,5	53	36	30	182	KOR20/16SOMD	400	250	
25	06	4	44	37,0	52	46	17	306	KOR25/06SOMD	400		
25	08	5	44	37,0	52	46	19	311	KOR25/08SOMD	400	250	
25	10	7	44	36,5	53	46	22	313	KOR25/10SOMD	400	250	
25	12	8	44	36,5	53	46	24	317	KOR25/12SOMD	400	250	
25	14	10	45	37,0	55	46	27	312	KOR25/14SOMD	400	250	
25	16	12	45	36,5	55	46	30	315	KOR25/16SOMD	400	250	
25	20	16	48	37,5	59	46	36	328	KOR25/20SOMD	400	250	
30	06	4	46	39,0	54	50	17	373	KOR30/06SOMD	400		
30	08	5	46	39,0	54	50	19	376	KOR30/08SOMD	400		
30	10	7	46	38,5	55	50	22	376	KOR30/10SOMD	400	250	
30	12	8	46	38,5	55	50	24	377	KOR30/12SOMD	400	250	
30	14	10	48	40,0	58	50	27	379	KOR30/14SOMD	400	250	
30	16	12	48	39,5	58	50	30	381	KOR30/16SOMD	400	250	
30	20	16	50	39,5	61	50	36	386	KOR30/20SOMD	400	250	
30	25	20	52	40,0	64	50	46	406	KOR30/25SOMD	400	250	
38	06	4	50	43,0	58	60	17	571	KOR38/06SOMD	315		
38	08	5	50	43,0	58	60	19	567	KOR38/08SOMD	315		
38	10	7	50	42,5	59	60	22	571	KOR38/10SOMD	315	200	
38	12	8	50	42,5	59	60	24	571	KOR38/12SOMD	315	200	

KOR Raccordo riduzione tubo – Acciaio e ottone

Codolo EO orientabile / Estremità conica EO 24°

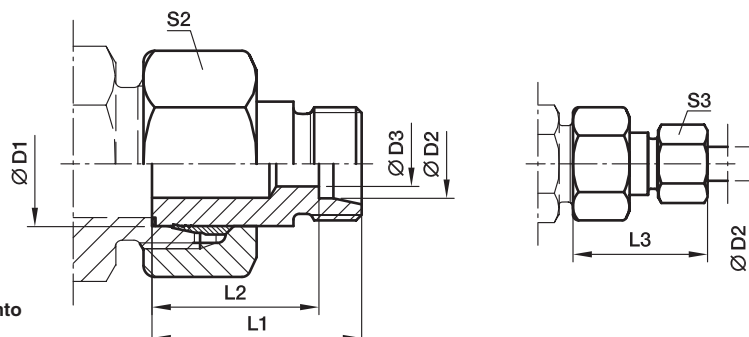

Con dado premontato e anello progressivo per la connessione.
Montaggio finale (in apposito corpo) almeno 1/4 di giro oltre il punto di resistenza chiaramente percepibile.

Serie	D1	D2	D3	L1	L2	L3	S2	S3	Peso g/1 pezzo	Codice di ordinazione*	PN (bar) ¹⁾	
											CF	MS
S ⁴⁾	38	14	10	52	44,0	62	60	27	575	KOR38/14SOMD	315	200
	38	16	12	52	43,5	62	60	30	580	KOR38/16SOMD	315	200
	38	20	16	54	43,5	65	60	36	593	KOR38/20SOMD	315	200
	38	25	20	56	44,0	68	60	46	605	KOR38/25SOMD	315	200
	38	30	25	58	44,5	71	60	50	614	KOR38/30SOMD	315	200

¹⁾ Pressione indicata = Articolo disponibile

⁴⁾ S = Serie pesante

$$\frac{\text{PN (bar)}}{10} = \text{PN (MPa)}$$

Consegna senza dado né anello. Per informazioni sull'ordinazione di raccordi completi vedere pag. 17.

Suffissi codice di ordinazione		
Materiale	Suffisso superficie e materiale	Esempio
Acciaio, zincato, esente da CromoVI	CF	KOR16/10SOMDCF
Ottone	MS	KOR16/10SOMDMS

*Aggiungere i **suffissi** qui di seguito in base al materiale e alla superficie richiesti.

KOR Raccordo riduzione tubo – Acciaio inossidabile

Codolo EO orientabile / Estremità conica EO 24°

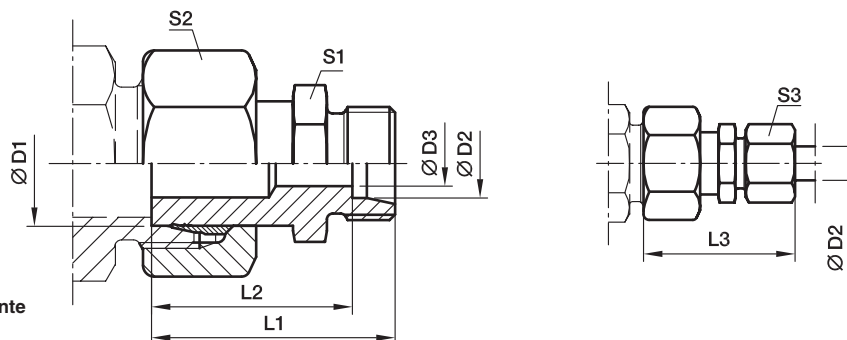

Con dado premontato e anello progressivo per la connessione. Montaggio finale (in apposito corpo) almeno 1/4 di giro oltre il punto di resistenza chiaramente percepibile.

Serie	D1	D2	D3	L1	L2	L3	S1	S2	S3	Peso g/1 pezzo	Codice di ordinazione*	PN (bar) ¹⁾
												71
L ³⁾	08	06	4	33,5	26,5	41	12	17	14	32	KOR08/06LOMD71	315
	10	06	4	34,5	27,5	42	12	19	14	39	KOR10/06LOMD71	315
	10	08	6	35,5	28,5	43	14	19	17	40	KOR10/08LOMD71	315
	12	06	4	36,5	29,5	44	14	22	14	49	KOR12/06LOMD71	315
	12	08	6	36,5	29,5	44	14	22	17	53	KOR12/08LOMD71	315
	12	10	8	37,5	30,5	45	17	22	19	55	KOR12/10LOMD71	315
	15	06	4	37,0	30,0	45	17	27	14	79	KOR15/06LOMD71	315
	15	08	6	37,0	30,0	45	17	27	17	78	KOR15/08LOMD71	315
	15	10	8	38,0	31,0	46	17	27	19	85	KOR15/10LOMD71	315
	15	12	10	39,0	32,0	47	19	27	22	84	KOR15/12LOMD71	315
	18	06	4	37,5	30,5	45	19	32	14	112	KOR18/06LOMD71	315
	18	08	6	37,5	30,5	45	19	32	17	113	KOR18/08LOMD71	315
	18	10	8	38,5	31,5	46	19	32	19	113	KOR18/10LOMD71	315
	18	12	10	38,5	31,5	46	19	32	22	122	KOR18/12LOMD71	315
	18	15	12	39,5	32,5	48	24	32	27	131	KOR18/15LOMD71	315
	22	06	4	38,5	31,5	46	24	36	14	154	KOR22/06LOMD71	160
	22	08	6	38,5	31,5	46	24	36	17	155	KOR22/08LOMD71	160
	22	10	8	39,5	32,5	47	24	36	19	156	KOR22/10LOMD71	160
	22	12	10	39,5	32,5	47	24	36	22	157	KOR22/12LOMD71	160
	22	15	12	40,5	33,5	49	24	36	27	160	KOR22/15LOMD71	160
	22	18	15	41,5	34,0	50	27	36	32	173	KOR22/18LOMD71	160
	28	06	4	41,0	34,0	49	30	41	14	220	KOR28/06LOMD71	160
	28	08	6	41,0	34,0	49	30	41	17	217	KOR28/08LOMD71	160
	28	10	8	42,0	35,0	50	30	41	19	211	KOR28/10LOMD71	160
	28	12	10	42,0	35,0	50	30	41	22	219	KOR28/12LOMD71	160
	28	15	12	43,0	36,0	51	30	41	27	188	KOR28/15LOMD71	160
	28	18	15	43,0	35,5	52	30	41	32	218	KOR28/18LOMD71	160
	28	22	19	45,0	37,5	54	32	41	36	228	KOR28/22LOMD71	160
	35	06	4	48,5	41,5	56	36	50	14	307	KOR35/06LOMD71	160
	35	08	6	48,5	41,5	56	36	50	17	313	KOR35/08LOMD71	160
	35	10	8	49,5	42,5	57	36	50	19	370	KOR35/10LOMD71	160
	35	12	10	49,5	42,5	57	36	50	22	371	KOR35/12LOMD71	160
	35	15	12	50,5	43,5	59	36	50	27	380	KOR35/15LOMD71	160
	35	18	15	50,5	43,0	59	36	50	32	382	KOR35/18LOMD71	160
	35	22	19	52,5	45,0	61	36	50	36	380	KOR35/22LOMD71	160
	35	28	24	52,5	45,0	62	41	50	41	400	KOR35/28LOMD71	160
42	10	8	52,5	45,5	60	46	60	19	551	KOR42/10LOMD71	160	
42	12	10	52,5	45,5	60	46	60	22	551	KOR42/12LOMD71	160	
42	15	12	53,5	46,5	62	46	60	27	687	KOR42/15LOMD71	160	
42	18	15	53,5	46,0	62	46	60	32	555	KOR42/18LOMD71	160	
42	22	19	55,5	48,0	64	46	60	36	568	KOR42/22LOMD71	160	
42	28	24	55,5	48,0	65	46	60	41	559	KOR42/28LOMD71	160	
42	35	30	57,5	47,0	69	46	60	50	588	KOR42/35LOMD71	160	

1) Pressione indicata = Articolo disponibile

3) L = Serie leggera

$\frac{PN(\text{bar})}{10} = PN(\text{MPa})$

Consegna senza dado né anello. Per informazioni sull'ordinazione di raccordi completi o sui materiali di tenuta alternativi vedere pag. 17.

KOR Raccordo riduzione tubo – Acciaio inossidabile

Codolo EO orientabile / Estremità conica EO 24°

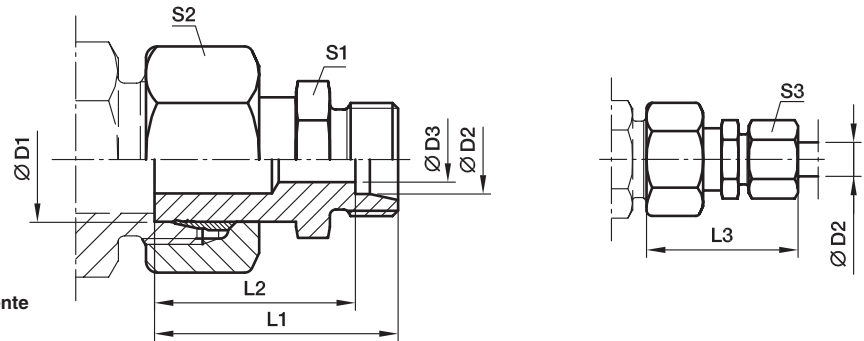

Con dado premontato e anello progressivo per la connessione. Montaggio finale (in apposito corpo) almeno 1/4 di giro oltre il punto di resistenza chiaramente percepibile.

Serie	D1	D2	D3	L1	L2	L3	S1	S2	S3	Peso g/1 pezzo	Codice di ordinazione*	PN (bar) ¹⁾
												71
S ⁴⁾	08	06	4	36,5	29,5	44	14	19	17	16	KOR08/06SOMD71	630
	10	06	4	38,5	31,5	46	14	22	17	16	KOR10/06SOMD71	630
	10	08	5	38,5	31,5	46	17	22	19	14	KOR10/08SOMD71	630
	12	06	4	38,5	31,5	46	14	24	17	16	KOR12/06SOMD71	630
	12	08	5	38,5	31,5	46	17	24	19	16	KOR12/08SOMD71	630
	12	10	7	39,5	32,0	48	19	24	22	27	KOR12/10SOMD71	630
	14	06	4	40,5	33,5	48	17	27	17	32	KOR14/06SOMD71	630
	14	08	5	40,5	33,5	48	17	27	19	34	KOR14/08SOMD71	630
	14	10	7	41,5	34,0	50	19	27	22	35	KOR14/10SOMD71	630
	14	12	8	41,5	34,0	50	22	27	24	41	KOR14/12SOMD71	630
	16	06	4	41,0	34,0	49	17	30	17	44	KOR16/06SOMD71	400
	16	08	5	41,0	34,0	49	17	30	19	45	KOR16/08SOMD71	400
16	10	7	42,0	34,5	51	19	30	22	46	KOR16/10SOMD71	400	
16	12	8	42,0	34,5	51	22	30	24	68	KOR16/12SOMD71	400	
16	14	10	44,0	36,0	54	24	30	27	69	KOR16/14SOMD71	400	
20	06	4	46,0	39,0	54	22	36	17	70	KOR20/06SOMD71	400	
20	08	5	46,0	39,0	54	22	36	19	70	KOR20/08SOMD71	400	
20	10	7	46,0	38,5	55	22	36	22	100	KOR20/10SOMD71	400	
20	12	8	46,0	38,5	55	22	36	24	101	KOR20/12SOMD71	400	
20	14	10	48,0	40,0	58	24	36	27	101	KOR20/14SOMD71	400	
20	16	12	49,0	40,5	59	27	36	30	101	KOR20/16SOMD71	400	
25	06	4	50,5	43,5	58	27	46	17	106	KOR25/06SOMD71	400	
25	08	5	50,5	43,5	58	27	46	19	136	KOR25/08SOMD71	400	
25	10	7	50,5	43,0	59	27	46	22	136	KOR25/10SOMD71	400	
25	12	8	50,5	43,0	59	27	46	24	138	KOR25/12SOMD71	400	
25	14	10	52,5	44,5	62	27	46	27	138	KOR25/14SOMD71	400	
25	16	12	52,5	44,0	62	27	46	30	143	KOR25/16SOMD71	400	
25	20	16	54,5	44,0	66	32	46	36	143	KOR25/20SOMD71	400	
30	06	4	53,0	46,0	61	32	50	17	177	KOR30/06SOMD71	400	
30	08	5	53,0	46,0	61	32	50	19	179	KOR30/08SOMD71	400	
30	10	7	53,0	45,5	62	32	50	22	180	KOR30/10SOMD71	400	
30	12	8	53,0	45,5	62	32	50	24	180	KOR30/12SOMD71	400	
30	14	10	55,0	47,0	65	32	50	27	185	KOR30/14SOMD71	400	
30	16	12	55,0	46,5	65	32	50	30	184	KOR30/16SOMD71	400	
30	20	16	57,0	46,5	68	32	50	36	188	KOR30/20SOMD71	400	
30	25	20	60,0	48,0	72	41	50	46	302	KOR30/25SOMD71	400	
38	06	4	60,0	53,0	68	41	60	17	306	KOR38/06SOMD71	315	
38	08	5	60,0	53,0	68	41	60	19	305	KOR38/08SOMD71	315	
38	10	7	60,0	52,5	69	41	60	22	304	KOR38/10SOMD71	315	
38	12	8	60,0	52,5	69	41	60	24	308	KOR38/12SOMD71	315	
38	14	10	62,0	54,0	72	41	60	27	316	KOR38/14SOMD71	315	
38	16	12	62,0	53,5	72	41	60	30	310	KOR38/16SOMD71	315	
38	20	16	64,0	53,5	75	41	60	36	305	KOR38/20SOMD71	315	
38	25	20	66,0	54,0	78	41	60	46	455	KOR38/25SOMD71	315	
38	30	25	69,0	55,5	82	46	60	50	438	KOR38/30SOMD71	315	

1) Pressione indicata = Articolo disponibile

4) S = Serie pesante

$$\frac{PN \text{ (bar)}}{10} = PN \text{ (MPa)}$$

Consegna senza dado né anello. Per informazioni sull'ordinazione di raccordi completi o sui materiali di tenuta alternativi vedere pag. 17.

GZ Raccordo intermedio con dado girevole

Dado girevole EO 24° DKO

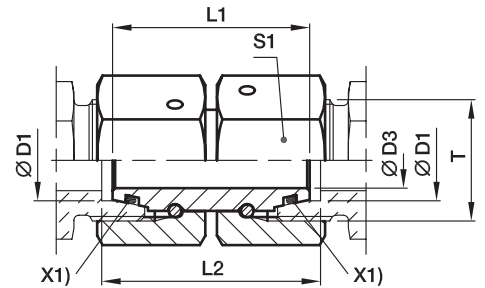

X1) O-ring OR

Serie	D1	T	D3	L1	L2	S1	Peso g/1 pezzo	Codice di ordinazione*	PN (bar) ¹⁾	
									CF	71
L ³⁾	06	M 12x1,5	2,5	32	33	14	28	GZ06L	500	315
	08	M 14x1,5	4,0	32	33	17	41	GZ08L	500	315
	10	M 16x1,5	6,0	33	34	19	53	GZ10L	500	315
	12	M 18x1,5	8,0	33	34	22	71	GZ12L	400	315
	15	M 22x1,5	10,0	38	39	27	129	GZ15L	400	315
	18	M 26x1,5	13,0	36	38	32	165	GZ18L	400	315
	22	M 30x2,0	17,0	42	44	36	243	GZ22L	250	160
	28	M 36x2,0	22,0	46	48	41	319	GZ28L	250	160
	35	M 45x2,0	28,0	48	52	50	449	GZ35L	250	160
	42	M 52x2,0	34,0	52	57	60	737	GZ42L	250	160
S ⁴⁾	06	M 14x1,5	2,5	32	33	17	41	GZ06S	800	630
	08	M 16x1,5	4,0	33	34	19	54	GZ08S	800	630
	10	M 18x1,5	6,0	33	35	22	74	GZ10S	800	630
	12	M 20x1,5	8,0	36	38	24	95	GZ12S	630	630
	14	M 22x1,5	9,0	39	41	27	131	GZ14S	630	630
	16	M 24x1,5	11,0	39	42	30	172	GZ16S	630	400
	20	M 30x2,0	14,0	44	48	36	261	GZ20S	420	400
	25	M 36x2,0	18,0	46	53	46	477	GZ25S	420	400
	30	M 42x2,0	23,0	52	62	50	605	GZ30S	420	400
	38	M 52x2,0	30,0	52	67	60	826	GZ38S	420	315

¹⁾ Pressione indicata = Articolo disponibile

³⁾ L = Serie leggera: ⁴⁾ S = Serie pesante

$$\frac{PN \text{ (bar)}}{10} = PN \text{ (MPa)}$$

Per informazioni sull'ordinazione di raccordi completi o sui materiali di tenuta alternativi vedere pag. 17.



Suffissi codice di ordinazione			
Materiale	Suffisso superficie e materiale	Esempio	Materiale di tenuta standard (non occorre suffisso aggiuntivo)
Acciaio, zincato, esente da CromoVI	CF	GZ16SCF	NBR
Acciaio inossidabile	71	GZ16S71	VIT

*Aggiungere i **suffissi** qui di seguito in base al materiale e alla superficie richiesti.

GZR Raccordo riduzione con dado girevole

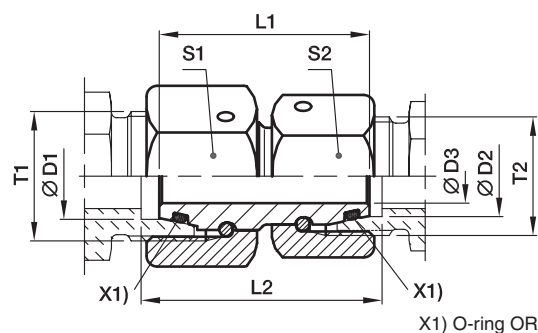
Dado girevole EO 24° DKO



Serie 3) 4)	D1 	D2 	T1	T2	D3	L1	L2	S1	S2	Peso g/1 pezzo	Codice di ordinazione*	PN (bar) ¹⁾ CF
L/S	06	06	M 14x1,5	M 12x1,5	2,5	32	33,0	17	14	34	GZR06L/06S	500
L	08	06	M 14x1,5	M 12x1,5	2,5	32	33,0	17	14	36	GZR08/06L	500
L/S	08	08	M 16x1,5	M 14x1,5	4,0	33	34,0	19	17	48	GZR08L/08S	500
L	10	06	M 16x1,5	M 12x1,5	2,5	33	34,0	19	14	44	GZR10/06L	500
L	10	08	M 16x1,5	M 14x1,5	4,0	33	34,0	19	17	50	GZR10/08L	500
L/S	10	10	M 18x1,5	M 16x1,5	6,0	33	34,5	22	19	63	GZR10L/10S	500
L	12	06	M 18x1,5	M 12x1,5	2,5	33	34,0	22	14	56	GZR12/06L	400
L	12	08	M 18x1,5	M 14x1,5	4,0	33	34,0	22	17	62	GZR12/08L	400
L	12	10	M 18x1,5	M 16x1,5	6,0	33	34,0	22	19	65	GZR12/10L	400
L/S	12	12	M 20x1,5	M 18x1,5	8,0	36	37,5	24	22	85	GZR12L/12S	400
L	15	08	M 22x1,5	M 14x1,5	4,0	38	39,0	27	17	98	GZR15/08L	400
L	15	10	M 22x1,5	M 16x1,5	6,0	38	39,0	27	19	101	GZR15/10L	400
L	15	12	M 22x1,5	M 18x1,5	8,0	38	39,0	27	22	108	GZR15/12L	400
L	18	10	M 26x1,5	M 16x1,5	6,0	36	37,5	32	19	125	GZR18/10L	400
L	18	12	M 26x1,5	M 18x1,5	8,0	36	37,5	32	22	132	GZR18/12L	400
L	18	15	M 26x1,5	M 22x1,5	10,0	38	39,5	32	27	155	GZR18/15L	400
L/S	18	16	M 26x1,5	M 24x1,5	11,0	39	41,5	32	30	177	GZR18L/16S	400
L	22	12	M 30x2,0	M 18x1,5	8,0	42	43,5	36	22	195	GZR22/12L	250
L	22	15	M 30x2,0	M 22x1,5	10,0	42	43,5	36	27	215	GZR22/15L	250
L	22	18	M 30x2,0	M 26x1,5	13,0	42	44,0	36	32	228	GZR22/18L	250
L/S	22	20	M 30x2,0	M 30x2,0	14,0	44	47,0	36	36	266	GZR22L/20S	250
L	28	15	M 36x2,0	M 22x1,5	10,0	46	47,5	41	27	143	GZR28/15L	250
L	28	18	M 36x2,0	M 26x1,5	13,0	46	48,0	41	32	311	GZR28/18L	250
L	28	22	M 36x2,0	M 30x2,0	17,0	46	46,0	41	36	309	GZR28/22L	250
L/S	28	25	M 36x2,0	M 36x2,0	18,0	46	50,5	41	46	419	GZR28L/25S	250
L	35	18	M 45x2,0	M 26x1,5	13,0	48	51,0	50	32	430	GZR35/18L	250
L	35	22	M 45x2,0	M 30x2,0	17,0	48	51,0	50	36	429	GZR35/22L	250
L	35	28	M 45x2,0	M 36x2,0	22,0	48	51,0	50	41	415	GZR35/28L	250
L/S	35	30	M 45x2,0	M 42x2,0	23,0	52	59,0	50	50	577	GZR35L/30S	250
L	42	22	M 52x2,0	M 30x2,0	17,0	52	55,5	60	36	653	GZR42/22L	250
L	42	28	M 52x2,0	M 36x2,0	22,0	52	55,5	60	41	648	GZR42/28L	250
L	42	35	M 52x2,0	M 45x2,0	28,0	52	56,5	60	50	662	GZR42/35L	250
L/S	42	38	M 52x2,0	M 52x2,0	30,0	52	62,0	60	60	822	GZR42L/38S	250
S	08	06	M 16x1,5	M 14x1,5	2,5	33	34,0	19	17	49	GZR08/06S	800
S	10	06	M 18x1,5	M 14x1,5	2,5	33	34,5	22	17	60	GZR10/06S	800
S	10	08	M 18x1,5	M 16x1,5	4,0	33	34,5	22	19	66	GZR10/08S	800
S	12	06	M 20x1,5	M 14x1,5	2,5	36	37,5	24	17	77	GZR12/06S	630
S	12	08	M 20x1,5	M 16x1,5	4,0	36	37,5	24	19	82	GZR12/08S	630
S	12	10	M 20x1,5	M 18x1,5	6,0	36	38,0	24	22	89	GZR12/10S	630
S	16	10	M 24x1,5	M 18x1,5	6,0	39	41,5	30	22	138	GZR16/10S	630
S	16	12	M 24x1,5	M 20x1,5	8,0	39	41,5	30	24	143	GZR16/12S	630
S/L	16	15	M 24x1,5	M 22x1,5	10,0	39	41,0	30	27	153	GZR16S/15L	400
S	20	12	M 30x2,0	M 20x1,5	8,0	44	47,0	36	24	204	GZR20/12S	420

GZR Raccordo riduzione con dado girevole

Dado girevole EO 24° DKO

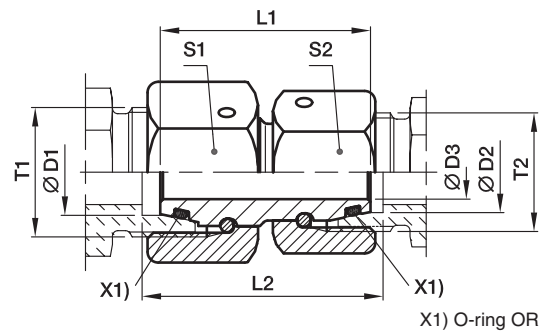

Serie ^{3) 4)}	D1	D2	T1	T2	D3	L1	L2	S1	S2	Peso g/1 pezzo	Codice di ordinazione*	PN (bar) ¹⁾ CF
S	20	16	M 30x2,0	M 24x1,5	11,0	44	47,5	36	30	232	GZR20/16S	420
S/L	20	18	M 30x2,0	M 26x1,5	13,0	44	47,0	36	32	224	GZR20S/18L	400
S	25	16	M 36x2,0	M 24x1,5	11,0	46	51,0	46	30	224	GZR25/16S	420
S	25	20	M 36x2,0	M 30x2,0	14,0	46	51,5	46	36	364	GZR25/20S	420
S/L	25	22	M 36x2,0	M 30x2,0	17,0	46	50,5	46	36	475	GZR25S/22L	250
S	30	16	M 42x2,0	M 24x1,5	11,0	52	58,5	50	30	475	GZR30/16S	420
S	30	20	M 42x2,0	M 30x2,0	14,0	52	59,0	50	36	500	GZR30/20S	420
S	30	25	M 42x2,0	M 36x2,0	18,0	52	60,5	50	46	589	GZR30/25S	420
S/L	30	28	M 42x2,0	M 36x2,0	22,0	52	58,0	50	41	476	GZR30S/28L	250
S	38	20	M 52x2,0	M 30x2,0	14,0	52	61,5	60	36	671	GZR38/20S	420
S	38	25	M 52x2,0	M 36x2,0	18,0	52	63,0	60	46	759	GZR38/25S	420
S	38	30	M 52x2,0	M 42x2,0	23,0	52	64,5	60	50	767	GZR38/30S	420
S/L	38	35	M 52x2,0	M 45x2,0	28,0	52	61,5	60	50	662	GZR38S/35L	250

¹⁾ Pressione indicata = Articolo disponibile

³⁾ L = Serie leggera: ⁴⁾ S = Serie pesante

$$\frac{\text{PN (bar)}}{10} = \text{PN (MPa)}$$

Per informazioni sull'ordinazione di raccordi completi o sui materiali di tenuta alternativi vedere pag. 17.

Suffissi codice di ordinazione			
Materiale	Suffisso superficie e materiale	Esempio	Materiale di tenuta standard (non occorre suffisso aggiuntivo)
Acciaio, zincato, esente da CromoVI	CF	GZR16/12SCF	NBR

*Aggiungere i **suffissi** qui di seguito in base al materiale e alla superficie richiesti.

GEO Terminale maschio dritto

Filettatura metrica maschio – O-ring (ISO 6149) / Estremità conica EO 24°

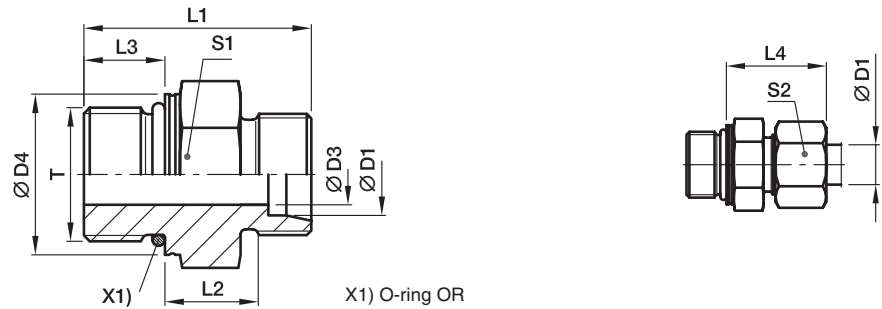

Serie	D1	T	D3	D4	L1	L2	L3	L4	S1	S2	Peso g/1 pezzo	Codice di ordinazione*	PN (bar) ¹⁾	
													CF	71
LL ²⁾	04	M 08x1,0	3,0	10,8	20,0	9,5	6,5	19,0	11	10	8	GEO04LLMOMD	100	
	04	M 10x1,0	3,0	12,8	20,0	9,5	6,5	19,0	13	10	11	GEO04LLM10X1OMD	100	
	06	M 10x1,0	4,5	12,8	20,0	8,0	6,5	19,5	13	12	10	GEO06LLMOMD	100	
L ³⁾	06	M 10x1,0	4,5	14,0	24,0	8,5	8,5	23,0	14	14	15	GEO06LMOMD	500	315
	08	M 12x1,5	6,0	17,0	28,0	10,0	11,0	25,0	17	17	23	GEO08LMOMD	500	315
	10	M 14x1,5	7,5	19,0	29,0	11,0	11,0	26,0	19	19	28	GEO10LMOMD	500	315
	12	M 16x1,5	9,0	22,0	31,0	12,5	11,5	27,0	22	22	40	GEO12LMOMD	400	315
	15	M 18x1,5	11,0	24,0	33,0	13,5	12,5	29,0	24	27	56	GEO15LMOMD	400	315
	18	M 22x1,5	14,0	27,0	35,0	14,5	13,0	31,0	27	32	80	GEO18LMOMD	400	315
	22	M 27x2,0	18,0	32,0	40,0	16,5	16,0	33,0	32	36	104	GEO22LM27X2OMD	250	160
	28	M 33x2,0	23,0	41,0	41,0	17,5	16,0	34,0	41	41	171	GEO28LMOMD	250	160
	35	M 42x2,0	30,0	50,0	44,0	17,5	16,0	39,0	50	50	278	GEO35LMOMD	250	160
	42	M 48x2,0	36,0	55,0	47,5	19,0	17,5	42,0	55	60	340	GEO42LMOMD	250	160
S ⁴⁾	06	M 12x1,5	4,0	17,0	31,0	13,0	11,0	28,0	17	17	29	GEO06SMOMD	800	630
	08	M 14x1,5	6,0	19,0	33,0	15,0	11,0	30,0	19	19	41	GEO08SMOMD	800	630
	10	M 16x1,5	7,0	22,0	35,0	15,0	12,5	31,0	22	22	55	GEO10SMOMD	800	630
	12	M 18x1,5	9,0	24,0	38,5	17,0	14,0	33,0	24	24	73	GEO12SMOMD	630	630
	16	M 22x1,5	12,0	27,0	42,0	18,5	15,0	37,0	27	30	102	GEO16SMOMD	630	400
	20	M 27x2,0	15,0	32,0	49,5	20,5	18,5	42,0	32	36	169	GEO20SMOMD	420	400
	25	M 33x2,0	20,0	41,0	53,5	23,0	18,5	47,0	41	46	274	GEO25SMOMD	420	400
	30	M 42x2,0	26,0	50,0	56,0	23,5	19,0	50,0	50	50	412	GEO30SMOMD	420	400
	38	M 48x2,0	32,0	55,0	63,5	26,0	21,5	57,0	55	60	580	GEO38SMOMD	420	315

¹⁾ Pressione indicata = Articolo disponibile

²⁾ LL = Serie ultraleggera; ³⁾ L = Serie leggera; ⁴⁾ S = Serie pesante

$$\frac{PN \text{ (bar)}}{10} = PN \text{ (MPa)}$$

Per informazioni sull'ordinazione di raccordi completi o sui materiali di tenuta alternativi vedere pag. 17.

Suffissi codice di ordinazione			
Materiale	Suffisso superficie e materiale	Esempio	Materiale di tenuta standard (non occorre suffisso aggiuntivo)
Acciaio, zincato, esente da CromoVI	CF	GEO16SMOMDCF	NBR
Acciaio inossidabile	71	GEO16SMOMD71	VIT

*Aggiungere i **suffissi** qui di seguito in base al materiale e alla superficie richiesti.

GE-M-ED Terminale maschio diritto

Filettatura metrica maschio – ED (ISO 9974) / Estremità conica EO 24°

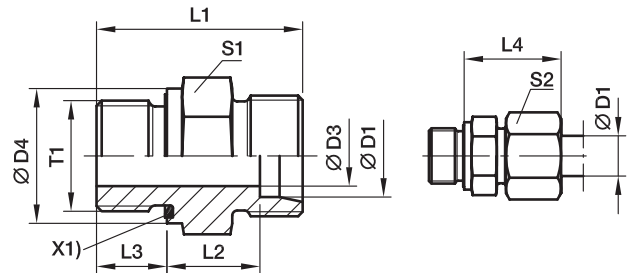

X1) Guarnizione Eolastic ED

Serie	D1	T1	D3	D4	L1	L2	L3	L4	S1	S2	Peso g/1 pezzo	Codice di ordinazione*	PN (bar) ¹⁾	
													CF	71
L3)	06	M 10x1,0	4	14	23,5	8,5	8	23	14	14	13	GE06LMEDOMD	500	315
	08	M 12x1,5	6	17	29,0	10,0	12	25	17	17	22	GE08LMEDOMD	500	315
	10	M 14x1,5	7	19	30,0	11,0	12	26	19	19	29	GE10LMEDOMD	500	315
	10	M 12x1,5	6	17	30,0	11,0	12	26	17	19	23	GE10LM12X1,5EDOMD	315	315
	10	M 16x1,5	8	22	31,5	12,5	12	24	22	19	40	GE10LM16X1,5EDOMD	420	315
	10	M 18x1,5	8	24	31,5	12,5	12	27	24	19	50	GE10LM18X1,5EDOMD	400	315
	10	M 22x1,5	8	27	35,0	14,0	14	29	27	19	80	GE10LM22X1,5EDOMD	400	315
	12	M 16x1,5	9	22	31,5	12,5	12	27	22	22	40	GE12LMEDOMD	400	315
	12	M 14x1,5	7	19	30,0	11,0	12	26	19	22	30	GE12LM14X1,5EDOMD	400	315
	12	M 18x1,5	10	24	31,5	12,5	12	27	24	22	47	GE12LM18X1,5EDOMD	400	315
	12	M 22x1,5	10	27	35,0	14,0	14	29	27	22	75	GE12LM22X1,5EDOMD	400	315
	15	M 18x1,5	11	24	32,5	13,5	12	29	24	27	51	GE15LMEDOMD	400	315
	15	M 16x1,5	9	22	32,0	13,0	12	28	24	27	64	GE15LM16X1,5EDOMD	400	315
	15	M 22x1,5	12	27	36,0	15,0	14	30	27	27	77	GE15LM22X1,5EDOMD	400	315
	18	M 22x1,5	14	27	36,0	14,5	14	31	27	32	74	GE18LMEDOMD	400	315
	18	M 18x1,5	11	24	33,5	14,0	12	30	27	32	68	GE18LM18X1,5EDOMD	400	315
	22	M 26x1,5	18	32	40,0	16,5	16	33	32	36	103	GE22LMEDOMD	250	160
	22	M 22x1,5	14	32	38,0	16,5	14	33	32	36	97	GE22LM22X1,5EDOMD	250	160
	28	M 33x2,0	23	40	43,0	17,5	18	34	41	41	168	GE28LMEDOMD	250	160
	35	M 42x2,0	30	50	48,0	17,5	20	39	50	50	281	GE35LMEDOMD	250	160
42	M 48x2,0	36	55	52,0	19,0	22	42	55	60	356	GE42LMEDOMD	250	160	
S4)	06	M 12x1,5	4	17	32,0	13,0	12	28	17	17	30	GE06SMEDOMD	800	630
	08	M 14x1,5	5	19	34,0	15,0	12	30	19	19	42	GE08SMEDOMD	800	630
	10	M 16x1,5	7	22	34,5	15,0	12	31	22	22	54	GE10SMEDOMD	800	630
	12	M 18x1,5	8	24	36,5	17,0	12	33	24	24	71	GE12SMEDOMD	630	630
	12	M 14x1,5	5	19	36,0	16,5	12	33	22	24	60	GE12SM14X1,5EDOMD	630	630
	12	M 22x1,5	8	27	39,0	17,5	14	34	27	24	102	GE12SM22X1,5EDOMD	630	400
	14	M 20x1,5	10	26	41,0	19,0	14	37	27	27	98	GE14SMEDOMD	630	630
	16	M 22x1,5	12	27	41,0	18,5	14	37	27	30	95	GE16SMEDOMD	630	400
	16	M 18x1,5	8	24	38,5	18,0	12	36	27	30	88	GE16SM18X1,5EDOMD	630	400
	20	M 27x2,0	16	32	47,0	20,5	16	42	32	36	150	GE20SMEDOMD	420	400
	25	M 33x2,0	20	40	53,0	23,0	18	47	41	46	264	GE25SMEDOMD	420	400
	30	M 42x2,0	25	50	57,0	23,5	20	50	50	50	422	GE30SMEDOMD	420	400
	38	M 48x2,0	32	55	64,0	26,0	22	57	55	60	569	GE38SMEDOMD	420	315

1) Pressione indicata = Articolo disponibile

3) L = Serie leggera; 4) S = Serie pesante

PN (bar) = PN (MPa)
10

Consegna senza dado né anello. Per informazioni sull'ordinazione di raccordi completi o sui materiali di tenuta alternativi vedere pag. 17.

*Aggiungere i suffissi qui di seguito in base al materiale e alla superficie richiesti.

Suffissi codice di ordinazione			
Materiale	Suffisso superficie e materiale	Esempio	Materiale di tenuta standard (non occorre suffisso aggiuntivo)
Acciaio, zincato, esente da CromoVI	CF	GE16SMEDOMDCF	NBR
Acciaio inossidabile	71	GE16SMEDOMD71	VIT

GE-R-ED Terminale maschio diritto

Filettatura maschio BSPP – Guarnizione ED (ISO 1179) / Estremità conica EO 24°

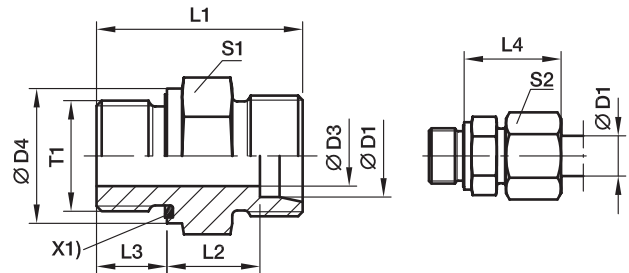

X1) Guarnizione Eolastic ED

Serie	D1	T1	D3	D4	L1	L2	L3	L4	S1	S2	Peso g/1 pezzo	Codice di ordinazione*	PN (bar) ¹⁾		
													CF	71	MS
LL ²⁾	04	G 1/8 A	3	14	20,0	9,5	6,5	19	14	10	10	GE04LLREDOMD	100	100	63
	06	G 1/8 A	4	14	20,0	8,0	6,5	20	14	12	11	GE06LLREDOMD	100	100	63
L ³⁾	06	G 1/8 A	4	14	23,5	8,5	8,0	23	14	14	13	GE06LREDOMD	500	315	200
	06	G 1/4 A	4	19	29,0	10,0	12,0	25	19	14	28	GE06LR1/4EDOMD	500	315	200
	06	G 3/8 A	4	22	30,5	11,5	12,0	26	22	14	44	GE06LR3/8EDOMD	420	315	200
	06	G 1/2 A	4	27	33,0	12,0	14,0	27	27	14	61	GE06LR1/2EDOMD	400	315	200
	08	G 1/4 A	6	19	29,0	10,0	12,0	25	19	17	27	GE08LREDOMD	500	315	200
	08	G 1/8 A	4	14	24,5	9,5	8,0	24	14	17	16	GE08LR1/8EDOMD	500	315	200
	08	G 3/8 A	6	22	30,5	11,5	12,0	26	22	17	45	GE08LR3/8EDOMD	420	315	200
	08	G 1/2 A	6	27	33,0	12,0	14,0	27	27	17	74	GE08LR1/2EDOMD	400	315	200
	10	G 1/4 A	6	19	30,0	11,0	12,0	26	19	19	29	GE10LREDOMD	500	315	200
	10	G 1/8 A	4	14	25,5	10,5	8,0	25	17	19	21	GE10LR1/8EDOMD	500	315	200
	10	G 3/8 A	8	22	31,5	12,5	12,0	27	22	19	43	GE10LR3/8EDOMD	420	315	200
	10	G 1/2 A	8	27	34,0	13,0	14,0	28	27	19	71	GE10LR1/2EDOMD	400	315	200
	12	G 3/8 A	9	22	31,5	12,5	12,0	27	22	22	41	GE12LREDOMD	420	315	200
	12	G 1/8 A	4	14	26,5	11,5	8,0	26	19	22	26	GE12LR1/8EDOMD	420	315	200
	12	G 1/4 A	6	19	31,0	12,0	12,0	27	19	22	31	GE12LR1/4EDOMD	400	315	200
	12	G 1/2 A	10	27	34,0	13,0	14,0	28	27	22	67	GE12LR1/2EDOMD	400	315	200
	12	G 3/4 A	10	32	37,0	14,0	16,0	29	32	22	118	GE12LR3/4EDOMD	250	160	100
	15	G 1/2 A	11	27	35,0	14,0	14,0	29	27	27	72	GE15LREDOMD	400	315	200
	15	G 3/8 A	9	22	32,5	13,5	12,0	29	24	27	54	GE15LR3/8EDOMD	400	315	200
	15	G 3/4 A	12	32	38,0	15,0	16,0	30	32	27	116	GE15LR3/4EDOMD	250	160	100
	18	G 1/2 A	14	27	36,0	14,5	14,0	31	27	32	71	GE18LREDOMD	400	315	200
	18	G 3/8 A	9	22	33,5	14,0	12,0	30	27	32	66	GE18LR3/8EDOMD	400	315	200
	18	G 3/4 A	15	32	38,0	14,5	16,0	31	32	32	110	GE18LR3/4EDOMD	250	160	100
	22	G 3/4 A	18	32	40,0	16,5	16,0	33	32	36	102	GE22LREDOMD	250	160	100
	22	G 1/2 A	14	27	38,0	16,5	14,0	33	32	36	91	GE22LR1/2EDOMD	250	160	100
	22	G 1 A	19	40	43,0	17,5	18,0	34	41	36	189	GE22LR1EDOMD	250	160	100
	28	G 1 A	23	40	43,0	17,5	18,0	34	41	41	170	GE28LREDOMD	250	160	100
	28	G 3/4 A	18	32	41,0	17,5	16,0	34	41	41	159	GE28LR3/4EDOMD	250	160	100
	28	G 1 1/4 A	24	50	46,0	18,5	20,0	35	50	41	316	GE28LR1/1/4EDOMD	250	160	100
	35	G 1 1/4 A	30	50	48,0	17,5	20,0	39	50	50	272	GE35LREDOMD	250	160	100
	35	G 1 A	23	40	46,0	17,5	18,0	39	46	50	226	GE35LR1EDOMD	250	160	100
	35	G 1 1/2 A	30	55	52,0	19,5	22,0	41	55	50	423	GE35LR1/1/2EDOMD	250	160	100
42	G 1 1/2 A	36	55	52,0	19,0	22,0	42	55	60	343	GE42LREDOMD	250	160	100	
42	G 1 A	23	40	48,0	19,0	18,0	42	55	60	324	GE42LR1EDOMD	250	160	100	
42	G 1 1/4 A	30	50	50,0	19,0	20,0	42	55	60	348	GE42LR1/1/4EDOMD	250	160	100	

1) Pressione indicata = Articolo disponibile

2) LL = Serie ultraleggera; 3) L = Serie leggera

$$\frac{PN \text{ (bar)}}{10} = PN \text{ (MPa)}$$

Consegna senza dado né anello. Per informazioni sull'ordinazione di raccordi completi o sui materiali di tenuta alternativi vedere pag. 17.

*Aggiungere i suffissi qui di seguito in base al materiale e alla superficie richiesti.

Suffissi codice di ordinazione			
Materiale	Suffisso superficie e materiale	Esempio	Materiale di tenuta standard (non occorre suffisso aggiuntivo)
Acciaio, zincato, esente da CromoVI	CF	GE18LREDOMDCF	NBR
Acciaio inossidabile	71	GE18LREDOMD71	VIT
Ottone	MS	GE18LREDOMDMS	NBR

GE-R-ED Terminale maschio diritto

Filettatura maschio BSPP – Guarnizione ED (ISO 1179) / Estremità conica EO 24°

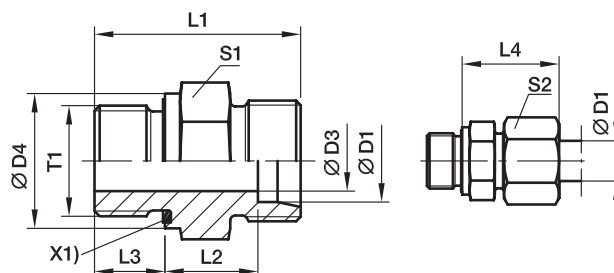

X1) Guarnizione Eolastic ED

Serie	D1	T1	D3	D4	L1	L2	L3	L4	S1	S2	Peso g/1 pezzo	Codice di ordinazione*	PN (bar) ¹⁾		
													CF	71	MS
S ⁴⁾	06	G 1/4 A	4	19	32,0	13,0	12	28	19	17	35	GE06SREDOMD	800	630	400
	06	G 1/8 A	4	14	27,5	12,5	8	27	14	17	21	GE06SR1/8EDOMD	500	315	
	06	G 3/8 A	4	22	34,5	15,5	12	30	22	17	52	GE06SR3/8EDOMD	630	630	
	06	G 1/2 A	4	27	39,0	18,0	14	33	27	17	83	GE06SR1/2EDOMD	630	400	
	08	G 1/4 A	5	19	34,0	15,0	12	30	19	19	41	GE08SREDOMD	800	630	400
	08	G 3/8 A	5	22	34,5	15,5	12	30	22	19	57	GE08SR3/8EDOMD	800	630	
	08	G 1/2 A	5	27	39,0	18,0	14	33	27	19	89	GE08SR1/2EDOMD	630	400	
	10	G 3/8 A	7	22	34,5	15,0	12	31	22	22	55	GE10SREDOMD	800	630	400
	10	G 1/4 A	5	19	34,0	14,5	12	31	19	22	42	GE10SR1/4EDOMD	800	630	
	10	G 1/2 A	7	27	39,0	17,5	14	34	27	22	97	GE10SR1/2EDOMD	630	630	
12	G 3/8 A	8	22	36,5	17,0	12	33	22	24	62	GE12SREDOMD	630	630	400	
12	G 1/4 A	5	19	36,0	16,5	12	33	22	24	61	GE12SR1/4EDOMD	630	630		
12	G 1/2 A	8	27	39,0	17,5	14	34	27	24	99	GE12SR1/2EDOMD	630	630		
14	G 1/2 A	10	27	41,0	19,0	14	37	27	27	96	GE14SREDOMD	630	630	400	
14	G 3/8 A	8	22	38,5	18,5	12	36	24	27	74	GE14SR3/8EDOMD	630	630		
14	G 3/4 A	10	32	45,0	21,0	16	39	32	27	138	GE14SR3/4EDOMD	420	400		
16	G 1/2 A	12	27	41,0	18,5	14	37	27	30	91	GE16SREDOMD	630	400	250	
16	G 3/8 A	8	22	38,5	18,0	12	36	27	30	83	GE16SR3/8EDOMD	630	400		
16	G 3/4 A	12	32	45,0	20,5	16	39	32	30	152	GE16SR3/4EDOMD	420	400		
20	G 3/4 A	16	32	47,0	20,5	16	42	32	36	149	GE20SREDOMD	420	400	250	
20	G 1/2 A	12	27	45,0	20,5	14	42	32	36	142	GE20SR1/2EDOMD	420	400		
20	G 1 A	16	40	51,0	22,5	18	44	41	36	265	GE20SR1EDOMD	420	400		
20	G 1 1/4 A	16	50	53,0	22,5	20	44	50	36	404	GE20SR11/4EDOMD	420	400		
25	G 1 A	20	40	53,0	23,0	18	47	41	46	266	GE25SREDOMD	420	400	250	
25	G 1/2 A	12	27	49,0	23,0	14	47	41	46	228	GE25SR1/2EDOMD	420	400		
25	G 3/4 A	16	32	51,0	23,0	16	47	41	46	255	GE25SR3/4EDOMD	420	400		
25	G 1 1/4 A	20	50	55,0	23,0	20	47	50	46	411	GE25SR11/4EDOMD	420	400		
25	G 1 1/2 A	20	55	60,0	26,0	22	50	55	46	549	GE25SR11/2EDOMD	315	315		
30	G 1 1/4 A	25	50	57,0	23,5	20	50	50	50	418	GE30SREDOMD	420	400	250	
30	G 1 A	20	40	55,0	23,5	18	50	46	50	344	GE30SR1EDOMD	420	400		
30	G 1 1/2 A	25	55	62,0	26,5	22	53	55	50	530	GE30SR11/2EDOMD	315	315		
38	G 1 1/2 A	32	55	64,0	26,0	22	57	55	60	563	GE38SREDOMD	420	315	200	
38	G 1 1/4 A	25	50	62,0	26,0	20	57	55	60	575	GE38SR11/4EDOMD	420	315		

1) Pressione indicata = Articolo disponibile

4) S = Serie pesante

$$\frac{PN \text{ (bar)}}{10} = PN \text{ (MPa)}$$

Consegna senza dado né anello. Per informazioni sull'ordinazione di raccordi completi o sui materiali di tenuta alternativi vedere pag. 17.

*Aggiungere i **suffixi** qui di seguito in base al materiale e alla superficie richiesti.

Suffixi codice di ordinazione			
Materiale	Suffisso superficie e materiale	Esempio	Materiale di tenuta standard (non occorre suffisso aggiuntivo)
Acciaio, zincato, esente da CromoVI	CF	GE16SREDOMDCF	NBR
Acciaio inossidabile	71	GE16SREDOMD71	VIT
Ottone	MS	GE16SREDOMDMS	NBR

GE-R Terminale maschio diritto

Filettatura maschio BSPP – bordo di tenuta metallico ED (ISO 1179) / Estremità conica EO 24°

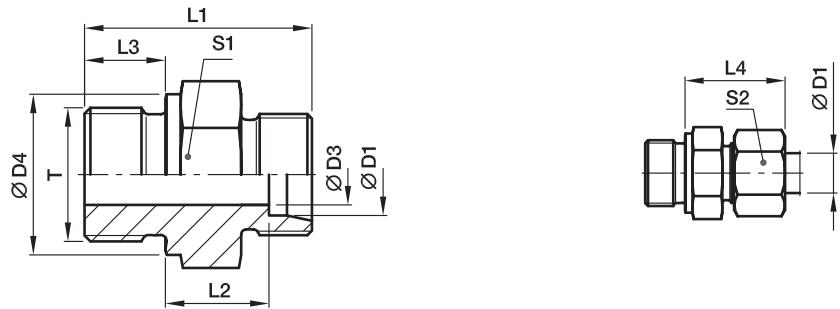

Serie	D1	T	D3	D4	L1	L2	L3	L4	S1	S2	Peso g/1 pezzo	Codice di ordinazione*	PN (bar) ¹⁾		
													CF	71	MS
L ³⁾	06	G 1/8 A	4	14	23,5	8,5	8	23,0	14	14	14	GE06LR	315	315	200
	06	G 1/4 A	4	18	29,0	10,0	12	25,0	19	14	60	GE06LR1/4	315	315	200
	06	G 3/8 A	4	22	30,5	11,5	12	26,0	22	14	45	GE06LR3/8	315	315	200
	06	G 1/2 A	4	26	33,0	12,0	14	27,0	27	14	60	GE06LR1/2	315	315	
	08	G 1/4 A	6	18	29,0	10,0	12	25,0	19	17	26	GE08LR	315	315	200
	08	G 1/8 A	4	14	24,5	8,5	8	23,0	14	17	16	GE08LR1/8	315	315	
	08	G 3/8 A	6	22	30,5	11,5	12	26,0	22	17	44	GE08LR3/8	315	315	200
	08	G 1/2 A	6	26	33,0	12,0	14	27,0	27	17	74	GE08LR1/2	315	315	200
	10	G 1/4 A	6	18	30,0	11,0	12	26,0	19	19	31	GE10LR	315	315	200
	10	G 1/8 A	4	14	25,5	10,5	8	25,0	17	19	21	GE10LR1/8	315	315	
	10	G 3/8 A	8	22	31,5	12,5	12	27,0	22	19	44	GE10LR3/8	315	315	200
	10	G 1/2 A	8	26	34,0	13,0	14	28,0	27	19	72	GE10LR1/2	315	315	200
12	G 3/8 A	9	22	31,5	12,5	12	27,0	22	22	43	GE12LR	315	315	200	
12	G 1/8 A	4	14	26,5	11,5	8	26,0	19	22	27	GE12LR1/8	315	315		
12	G 1/4 A	6	18	31,0	12,0	12	27,0	19	22	32	GE12LR1/4	315	315	200	
12	G 1/2 A	10	26	34,0	13,0	14	28,0	27	22	67	GE12LR1/2	315	315	200	
12	G 3/4 A	10	32	37,0	14,0	16	29,0	32	22	120	GE12LR3/4	315	315		
15	G 1/2 A	11	26	35,0	14,0	14	29,0	27	27	72	GE15LR	250	250	160	
15	G 3/8 A	9	22	32,5	13,5	12	29,0	24	27	56	GE15LR3/8	250	250	160	
15	G 3/4 A	12	32	38,0	15,0	16	30,0	32	27	118	GE15LR3/4	250	250		
18	G 1/2 A	14	26	36,0	14,5	14	31,0	27	32	72	GE18LR	250	250	160	
18	G 3/8 A	9	22	33,5	14,0	12	29,5	27	32	69	GE18LR3/8	250	250		
18	G 3/4 A	15	32	38,0	14,5	16	30,0	32	32	112	GE18LR3/4	250	250		
22	G 3/4 A	18	32	40,0	16,5	16	33,0	32	36	103	GE22LR	160	160	100	
22	G 1/2 A	14	26	38,0	16,5	14	33,0	32	36	91	GE22LR1/2	160	160	100	
22	G 1 A	19	39	43,0	17,5	18	33,5	41	36	184	GE22LR1	160	160		
28	G 1 A	23	39	43,0	17,5	18	34,0	41	41	168	GE28LR	160	160	100	
28	G 1/2 A	14	26	39,0	17,5	14	34,0	41	41	141	GE28LR1/2	160	160		
28	G 3/4 A	18	32	41,0	17,5	16	34,0	41	41	156	GE28LR3/4	160	160		
28	G 1 1/4 A	24	50	46,0	18,3	20	35,0	50	41	314	GE28LR11/4	160	160		
35	G 1 1/4 A	30	49	48,0	17,5	20	39,0	50	50	276	GE35LR	160	160	100	
35	G 1/2 A	14	26	42,0	17,5	14	39,0	46	50	194	GE35LR1/2	160	160		
35	G 3/4 A	18	32	44,0	17,5	16	39,0	46	50	202	GE35LR3/4	160	160		
35	G 1 A	23	39	46,0	17,5	18	39,0	46	50	234	GE35LR1	160	160		
35	G 1 1/2 A	30	55	52,0	19,5	22	41,0	55	50	355	GE35LR11/2	160	160		
42	G 1 1/2 A	36	55	52,0	19,0	22	42,0	55	60	349	GE42LR	160	160	100	
42	G 1 A	23	39	48,0	19,0	18	42,0	55	60	327	GE42LR1	160	160		
42	G 1 1/4 A	30	49	50,0	19,0	20	42,0	55	60	336	GE42LR11/4	160	160		

¹⁾ Pressione indicata = Articolo disponibile

³⁾ L = Serie leggera

$$\frac{PN(\text{bar})}{10} = PN(\text{MPa})$$

Consegna senza dado né anello. Per informazioni sull'ordinazione di raccordi completi vedere pag. 17.

*Aggiungere i suffissi qui di seguito in base al materiale e alla superficie richiesti.

Suffissi codice di ordinazione		
Materiale	Suffisso superficie e materiale	Esempio
Acciaio, zincato, esente da CromoVI	CFX	GE18LRCFX
Acciaio inossidabile	71X	GE18LR71X
Ottone	MSX	GE18LRMSX

GE-R Terminale maschio diritto

Filettatura maschio BSPP – bordo di tenuta metallico ED (ISO 1179) / Estremità conica EO 24°

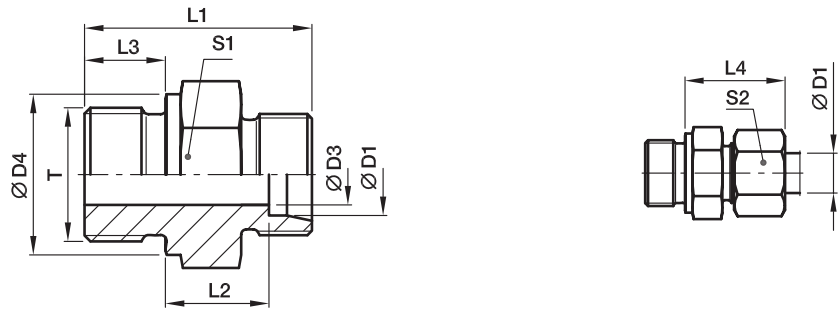

Serie	D1	T	D3	D4	L1	L2	L3	L4	S1	S2	Peso g/1 pezzo	Codice di ordinazione*	PN (bar) ¹⁾		
													CF	71	MS
S ⁴⁾	06	G 1/4 A	4	18	32,0	13,0	12	28	19	17	35	GE06SR	400	400	250
	06	G 1/8 A	3	14	27,5	12,5	8	27	14	17	22	GE06SR1/8	400	400	
	06	G 3/8 A	4	22	34,5	15,5	12	30	22	17	57	GE06SR3/8	400	400	
	06	G 1/2 A	4	26	39,0	18,0	14	33	27	17	83	GE06SR1/2	400	400	
	08	G 1/4 A	5	18	34,0	15,0	12	30	19	19	41	GE08SR	400	400	250
	08	G 3/8 A	5	22	34,5	15,5	12	30	22	19	59	GE08SR3/8	400	400	
	08	G 1/2 A	5	26	39,0	18,0	14	33	27	19	100	GE08SR1/2	400	400	
	10	G 3/8 A	7	22	34,5	15,0	12	31	22	22	56	GE10SR	400	400	250
	10	G 1/4 A	5	18	34,0	14,5	12	31	19	22	43	GE10SR1/4	400	400	
	10	G 1/2 A	7	26	39,0	17,5	14	34	27	22	97	GE10SR1/2	400	400	
	12	G 3/8 A	8	22	36,5	17,0	12	33	22	24	62	GE12SR	400	400	250
	12	G 1/4 A	5	18	36,0	16,5	12	33	22	24	57	GE12SR1/4	400	400	
	12	G 1/2 A	8	26	39,0	17,5	14	34	27	24	57	GE12SR1/2	400	400	
	14	G 1/2 A	10	26	41,0	19,0	14	37	27	27	96	GE14SR	400	400	250
	14	G 3/8 A	8	22	38,5	18,5	12	36	24	27	74	GE14SR3/8	400	400	
	16	G 1/2 A	12	26	41,0	18,5	14	37	27	30	92	GE16SR	400	400	250
	16	G 3/8 A	8	22	38,5	18,0	12	36	27	30	83	GE16SR3/8	400	400	
	16	G 3/4 A	12	32	45,0	20,5	16	39	32	30	157	GE16SR3/4	400	400	
	20	G 3/4 A	16	32	47,0	20,5	16	42	32	36	151	GE20SR	400	400	250
	20	G 1/2 A	12	26	45,0	20,5	14	42	32	36	142	GE20SR1/2	400	400	
20	G 1 A	16	39	51,0	22,5	18	44	41	36	273	GE20SR1	250	250		
20	G 1 1/4 A	16	49	53,0	22,5	20	44	50	36	387	GE20SR11/4	160	160		
25	G 1 A	20	39	53,0	23,0	18	47	41	46	267	GE25SR	250	250	160	
25	G 3/4 A	16	32	51,0	23,0	16	47	41	46	245	GE25SR3/4	250	250		
25	G 1 1/4 A	20	49	55,0	23,0	20	47	50	46	422	GE25SR11/4	160	160		
30	G 1 1/4 A	25	49	57,0	23,5	20	50	50	50	422	GE30SR	160	160	100	
30	G 1 A	20	39	55,0	23,5	18	50	46	50	337	GE30SR1	160	160		
38	G 1 1/2 A	32	55	64,0	26,0	22	57	55	60	560	GE38SR	160	160	100	
38	G 1 1/4 A	25	49	62,0	26,0	20	57	55	60	578	GE38SR11/4	160	160		

1) Pressione indicata = Articolo disponibile

4) S = Serie pesante

$$\frac{\text{PN (bar)}}{10} = \text{PN (MPa)}$$

Consegna senza dado né anello. Per informazioni sull'ordinazione di raccordi completi vedere pag. 17.

*Aggiungere i **suffissi** qui di seguito in base al materiale e alla superficie richiesti.

Suffissi codice di ordinazione		
Materiale	Suffisso superficie e materiale	Esempio
Acciaio, zincato, esente da CromoVI	CFX	GE16SRCFX
Acciaio inossidabile	71X	GE16SR71X
Ottone	MSX	GE16SRMSX

GE-R(KEG) Terminale maschio diritto

Filettatura maschio BSPT conica corta (DIN 3852-2, tipo C) / Estremità conica EO 24°

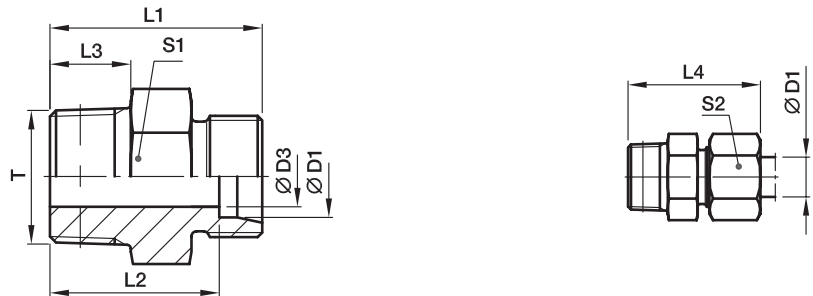

Serie	D1	T	D3	L1	L2	L3	L4	S1	S2	Peso g/1 pezzo	Codice di ordinazione*	PN (bar) ¹⁾		
												CF	71	MS
LL ²⁾	04	R 1/8 keg.	3,0	20	16,0	8	26	11*	10	8	GE04LLR	100	100	63
	06	R 1/8 keg.	4,5	20	14,5	8	26	11*	12	8	GE06LLR	100	100	63
	08	R 1/8 keg.	6,0	22	16,5	8	28	12	14	10	GE08LLR	100	100	63
	08	R 1/4 keg.	6,0	26	20,5	12	32	14	14	18	GE08LLR1/4	100	100	63
	10	R 1/4 keg.	8,0	26	20,5	12	32	14	17	15	GE10LLR	100		63
	12	R 1/4 keg.	8,0	26	20,0	12	32	17	19	18	GE12LLR	100		63
	12	R 3/8 keg.	10,0	26	20,0	12	32	17	19	23	GE12LLR3/8	100		63
L ³⁾	06	R 1/8 keg.	4,0	22	15,0	8	30	12	14	11	GE06LR1/8KEG	315	315	
	06	R 1/4 keg.	4,0	27	20,0	12	35	17	14	24	GE06LR1/4KEG	315	315	200
	08	R 1/8 keg.	4,0	23	16,0	8	31	14	17	15	GE08LR1/8KEG	315	315	200
	08	R 1/4 keg.	6,0	27	20,0	12	35	17	17	22	GE08LR1/4KEG	315	315	
	10	R 1/4 keg.	7,0	28	21,0	12	36	17	19	24	GE10LR1/4KEG	315	315	
	12	R 1/4 keg.	7,0	29	22,0	12	37	19	22	53	GE12LR1/4KEG	315	315	200
	12	R 3/8 keg.	9,0	29	22,0	12	37	19	22	33	GE12LR3/8KEG	315	315	
	12	R 1/2 keg.	10,0	31	24,0	14	39	24	22	53	GE12LR1/2KEG	315	315	200
	15	R 3/8 keg.	9,0	30	23,0	12	38	24	27	49	GE15LR3/8KEG	315	315	200
	15	R 1/2 keg.	11,0	32	25,0	14	40	24	27	59	GE15LR1/2KEG	315	315	
	18	R 1/2 keg.	14,0	33	25,5	14	42	27	32	64	GE18LR1/2KEG	315	315	
	22	R 3/4 keg.	17,0	37	29,5	16	46	32	36	99	GE22LR3/4KEG	160	160	
	28	R 1 keg.	23,0	40	32,5	18	49	41	41	154	GE28LR1KEG	160	160	
	35	R 1 1/4 keg.	30,0	45	34,5	20	56	46	50	238	GE35LR11/4KEG	160	160	
42	R 1 1/2 keg.	36,0	49	38,0	22	61	55	60	335	GE42LR11/2KEG	160	160		

¹⁾ Pressione indicata = Articolo disponibile

²⁾ LL = Serie ultraleggera; ³⁾ L = Serie leggera

$$\frac{PN \text{ (bar)}}{10} = PN \text{ (MPa)}$$

Consegna senza dado né anello. Per informazioni sull'ordinazione di raccordi completi vedere pag. 17.

^{*}) S1 = 12 per 1.4571

Suffissi codice di ordinazione		
Materiale	Suffisso superficie e materiale	Esempio
Acciaio, zincato, esente da CromoVI	CFX	GE06LR1/4KEGCFX
Acciaio inossidabile	71X	GE06LR1/4KEG71X
Ottone	MSX	GE06LR1/4KEGMSX

*Aggiungere i suffissi qui di seguito in base al materiale e alla superficie richiesti.

GE-M Terminale maschio diritto

Filettatura maschio metrica – bordo di tenuta metallico (ISO 9974) / Estremità conica EO 24°

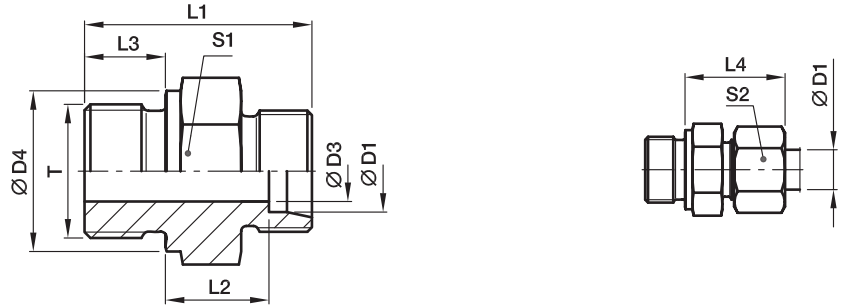

Serie	D1	T	D3	D4	L1	L2	L3	L4	S1	S2	Peso g/1 pezzo	Codice di ordinazione*	PN (bar) ¹⁾		
													CF	71	MS
L ³⁾	06	M 10x1,0	4	14	23,5	8,5	8	23	14	14	13	GE06LM	315	315	200
	08	M 12x1,5	6	17	29,0	10,0	12	25	17	17	22	GE08LM	315	315	200
	10	M 14x1,5	7	19	30,0	11,0	12	26	19	19	31	GE10LM	315	315	200
	10	M 10x1,0	4	14	25,5	10,5	8	25	17	19	20	GE10LM10X1	315	315	
	10	M 12x1,5	6	17	30,0	11,0	12	26	17	19	25	GE10LM12X1,5	315	315	
	10	M 16x1,5	8	21	31,5	12,0	12	27	22	19	41	GE10LM16X1,5	315	315	
	10	M 18x1,5	8	23	31,5	12,5	12	27	24	19	50	GE10LM18X1,5	315	315	
	10	M 22x1,5	8	27	35,0	14,0	14	29	27	19	72	GE10LM22X1,5	315	315	
	12	M 14x1,5	7	19	30,0	11,0	12	26	19	22	30	GE12LM14X1,5	315	315	
	12	M 16x1,5	9	21	31,5	12,5	12	27	22	22	40	GE12LM	315	315	
	12	M 18x1,5	10	23	31,5	12,5	12	27	24	22	47	GE12LM18X1,5	315	315	
	12	M 22x1,5	10	27	35,0	14,0	14	29	27	22	76	GE12LM22X1,5	315	315	
	15	M 16x1,5	9	21	32,0	13,0	12	28	24	27	50	GE15LM16X1,5	250	250	
	15	M 18x1,5	11	23	32,5	13,5	12	29	24	27	52	GE15LM	250	250	160
	15	M 22x1,5	12	27	36,0	15,0	14	30	27	27	77	GE15LM22X1,5	250	250	
	18	M 18x1,5	11	23	33,5	14,0	12	30	27	32	68	GE18LM18X1,5	250	250	
	18	M 22x1,5	14	27	36,0	14,5	14	31	27	32	77	GE18LM	250	250	160
	22	M 22x1,5	14	27	38,0	16,5	14	33	32	36	92	GE22LM22X1,5	160	160	
	22	M 26x1,5	18	31	40,0	16,5	16	33	32	36	102	GE22LM	160	160	100
	28	M 33x2,0	23	39	43,0	17,5	18	34	41	41	168	GE28LM	160	160	100
35	M 42x2,0	30	49	48,0	17,5	20	39	50	50	280	GE35LM	160	160	100	
42	M 48x2,0	36	55	52,0	19,0	22	42	55	60	354	GE42LM	160	160	100	
S ⁴⁾	06	M 12x1,5	4	17	32,0	13,0	12	28	17	17	30	GE06SM	400	400	250
	06	M 14x1,5	4	19	34,0	15,0	12	30	19	17	42	GE06SM14X1,5	400	400	
	08	M 14x1,5	5	19	34,0	15,0	12	30	19	19	43	GE08SM	400	400	250
	10	M 16x1,5	7	21	34,5	15,0	12	31	22	22	54	GE10SM	400	400	250
	12	M 18x1,5	8	23	36,5	17,0	12	33	24	24	72	GE12SM	400	400	250
	12	M 14x1,5	5	19	36,0	16,5	12	33	22	24	60	GE12SM14X1,5	400	400	
	12	M 22x1,5	8	27	39,0	17,5	14	34	27	24	103	GE12SM22X1,5	400	400	
	14	M 20x1,5	10	25	41,0	19,0	14	37	27	27	95	GE14SM	400	400	250
	16	M 18x1,5	8	23	38,5	18,0	12	36	27	30	88	GE16SM18X1,5	400	400	
	16	M 22x1,5	12	27	41,0	18,5	14	37	27	30	97	GE16SM	400	400	250
	20	M 27x2,0	16	32	47,0	20,5	16	42	32	36	155	GE20SM	400	400	250
	25	M 33x2,0	20	39	53,0	23,0	18	47	41	46	268	GE25SM	250	250	160
	30	M 42x2,0	25	49	57,0	23,5	20	50	50	50	421	GE30SM	160	160	100
	38	M 48x2,0	32	55	64,0	26,0	22	57	55	60	568	GE38SM	160	160	100

¹⁾ Pressione indicata = Articolo disponibile

³⁾ L = Serie leggera; ⁴⁾ S = Serie pesante

PN (bar) = PN (MPa)
10

Consegna senza dado né anello. Per informazioni sull'ordinazione di raccordi completi vedere pag. 17.

*Aggiungere i **suffissi** qui di seguito in base al materiale e alla superficie richiesti.

Suffissi codice di ordinazione		
Materiale	Suffisso superficie e materiale	Esempio
Acciaio, zincato, esente da CromoVI	CFX	GE16SMCFX
Acciaio inossidabile	71X	GE16SM71X
Ottone	MSX	GE16SMMSX

GE-M(KEG) Terminale maschio diritto

Filettatura maschio metrica conica corta (DIN 3852-1, tipo C) / Estremità conica EO 24°

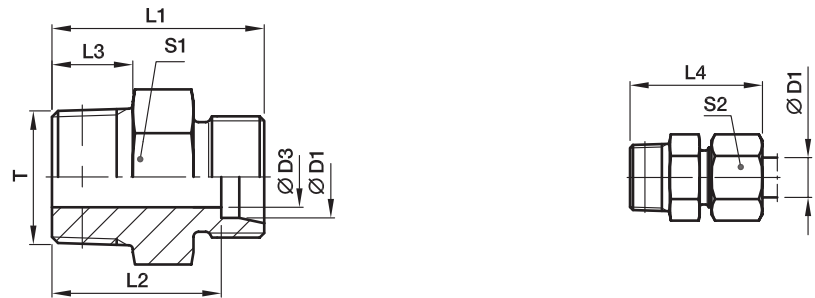

Serie	D1	T	D3	L1	L2	L3	L4	S1	S2	Peso g/1 pezzo	Codice di ordinazione*	PN (bar) ¹⁾		
												CF	71	MS
LL ²⁾	04	M 06x1,0 keg.	2,0	20	16,0	8	26	9	10	5	GE04LLM6X1KEG	100		
	04	M 08x1,0 keg.	3,0	20	16,0	8	26	10	10	7	GE04LLM	100	100	63
	06	M 10x1,0 keg.	4,5	20	14,5	8	26	11	12	9	GE06LLM	100	100	63
	06	M 08x1,0 keg.	3,5	20	14,5	8	26	11	12	9	GE06LLM8X1KEG	100		
	08	M 10x1,0 keg.	6,0	22	16,5	8	28	12	14	10	GE08LLM	100	100	63

¹⁾ Pressione indicata = Articolo disponibile

²⁾ LL = Serie ultraleggera

$\frac{PN \text{ (bar)}}{10} = PN \text{ (MPa)}$

Consegna senza dado né anello. Per informazioni sull'ordinazione di raccordi completi vedere pag. 17.

Suffissi codice di ordinazione		
Materiale	Suffisso superficie e materiale	Esempio
Acciaio, zincato, esente da CromoVI	CFX	GE06LLMCFX
Acciaio inossidabile	71X	GE06LLM71X
Ottone	MSX	GE06LLMMSX

*Aggiungere i **suffissi** qui di seguito in base al materiale e alla superficie richiesti.

GE-UNF/UN Terminale maschio diritto

Filettatura maschio UNF/UN – O-ring (ISO 11926) / Estremità conica EO 24°

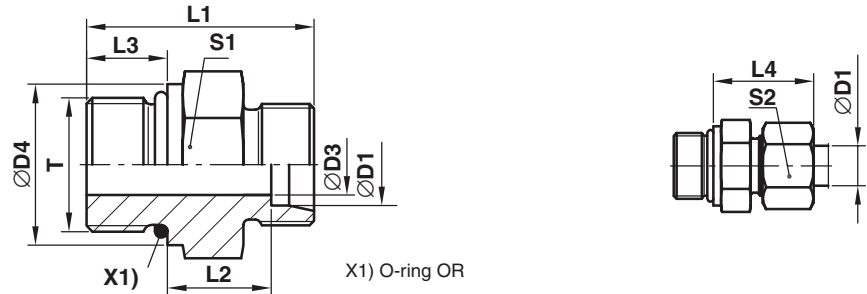

X1) O-ring OR

Serie	D1	T	D3	D4	L1	L2	L3	L4	S1	S2	Peso g/1 pezzo	Codice di ordinazione*	PN (bar) ¹⁾	
													CF	71
L ³⁾	08	7/16-20UNF-2A	5,0	–	26	10,0	9,0	25	17	17	21	GE08L7/16UNFOMD	315	315
	10	7/16-20UNF-2A	5,0	–	27	11,0	9,0	26	17	19	23	GE10L7/16UNFOMD	315	315
	12	9/16-18UNF-2A	7,0	–	28	11,0	10,0	26	19	22	32	GE12L9/16UNFOMD	315	315
	12	3/4-16UNF-2A	10,0	–	31	13,0	11,0	28	24	22	52	GE12L3/4UNFOMD	315	315
	12	7/8-14UNF-2A	10,0	–	34	14,3	12,7	29	27	22	77	GE12L7/8UNFOMD	315	315
	15	3/4-16UNF-2A	11,0	–	32	14,0	11,0	29	24	27	57	GE15L3/4UNFOMD	315	315
	15	7/8-14UNF-2A	12,0	–	35	15,3	12,7	30	27	27	81	GE15L7/8UNFOMD	315	315
	18	3/4-16UNF-2A	11,0	23,9	33	14,5	11,0	31	27	32	68	GE18L3/4UNFOMD	315	315
	18	7/8-14UNF-2A	14,0	–	35	14,8	12,7	31	27	32	72	GE18L7/8UNFOMD	315	315
	22	7/8-14UNF-2A	14,0	26,9	37	16,8	12,7	33	32	36	94	GE22L7/8UNFOMD	160	160
	22	1 1/16-12UN-2A	18,0	–	39	16,5	15,0	33	32	36	103	GE22L11/16UNOMD	160	160
	22	1 5/16-12UN-2A	19,0	–	40	17,5	15,0	34	41	36	163	GE22L15/16UNOMD	160	160
	28	1 1/16-12UN-2A	18,0	33,3	40	17,5	15,0	34	41	41	152	GE28L11/16UNOMD	160	160
	28	1 5/16-12UN-2A	23,0	–	40	17,5	15,0	34	41	41	163	GE28L15/16UNOMD	160	160
	35	1 5/16-12UN-2A	23,0	39,6	43	17,5	15,0	39	46	50	222	GE35L15/16UNOMD	160	160
	35	1 5/8-12UN-2A	29,0	–	43	17,5	15,0	39	50	50	257	GE35L15/8UNOMD	160	160
42	1 5/8-12UN-2A	29,0	47,7	45	19,0	15,0	42	55	60	339	GE42L15/8UNOMD	160	160	
S ⁴⁾	08	7/16-20UNF-2A	4,0	–	31	13,0	11,0	30	17	19	33	GE08S7/16UNFOMD	630	630
	10	9/16-18UNF-2A	6,0	–	32	12,5	12,0	31	19	22	42	GE10S9/16UNFOMD	630	630
	12	9/16-18UNF-2A	6,0	19,0	32	12,5	12,0	31	22	24	50	GE12S9/16UNFOMD	630	630
	12	3/4-16UNF-2A	8,0	–	36	14,5	14,0	34	24	24	73	GE12S3/4UNFOMD	630	630
	16	3/4-16UNF-2A	10,0	–	35	12,5	14,0	34	24	30	90	GE16S3/4UNFOMD	400	400
	16	7/8-14UNF-2A	12,0	–	40	15,5	16,0	37	27	30	95	GE16S7/8UNFOMD	400	400
	20	3/4-16UNF-2A	10,0	23,9	42	17,5	14,0	42	32	36	132	GE20S3/4UNFOMD	400	400
	20	7/8-14UNF-2A	12,0	26,9	44	17,5	16,0	42	32	36	141	GE20S7/8UNFOMD	400	400
	20	1 1/16-12UN-2A	16,0	–	46	17,0	18,5	42	32	36	163	GE20S11/16UNOMD	400	400
	25	1 1/16-12UN-2A	16,0	33,3	50	19,5	18,5	47	36	46	206	GE25S11/16UNOMD	400	400
	25	1 5/16-12UN-2A	20,0	–	50	19,5	18,5	47	41	46	258	GE25S15/16UNOMD	400	400
	30	1 5/16-12UN-2A	20,0	39,6	52	20,0	18,5	50	46	50	327	GE30S15/16UNOMD	400	400
	30	1 5/8-12UN-2A	24,0	–	52	20,0	18,5	50	50	50	422	GE30S15/8UNOMD	400	400
	38	1 5/8-12UN-2A	24,0	47,7	57	22,5	18,5	57	55	60	554	GE38S15/8UNOMD	315	315

¹⁾ Pressione indicata = Articolo disponibile

³⁾ L = Serie leggera; ⁴⁾ S = Serie pesante

PN (bar)
10 = PN (MPa)

Consegna senza dado né anello. Per informazioni sull'ordinazione di raccordi completi o sui materiali di tenuta alternativi vedere pag. 17.

*Aggiungere i suffissi qui di seguito in base al materiale e alla superficie richiesti.

Suffissi codice di ordinazione			
Materiale	Suffisso superficie e materiale	Esempio	Materiale di tenuta standard (non occorre suffisso aggiuntivo)
Acciaio, zincato, esente da CromoVI	CF	GE16S3/4UNFOMDCF	NBR
Acciaio inossidabile	71	GE16S3/4UNFOMD71	VIT

GE-NPT Terminale maschio diritto

Filettatura maschio NPT (SAE J476) / Estremità conica EO 24°

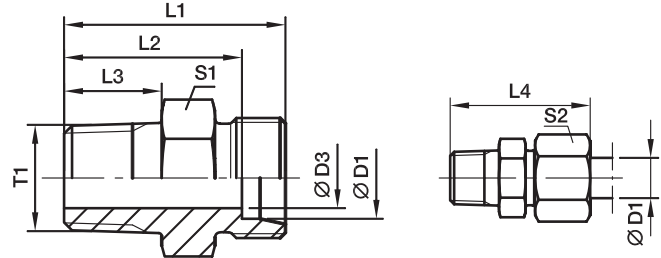

Serie	D1	T1	D3	L1	L2	L3	L4	S1	S2	Peso g/1 pezzo	Codice di ordinazione*	PN (bar) ¹⁾		
												CF	71	MS
LL ²⁾	04	1/8-27 NPT	3,0	22,0	18,0	10,0	28	11	10	9	GE04LL1/8NPT	100	100	
	06	1/8-27 NPT	4,5	22,0	16,5	10,0	28	11	12	9	GE06LL1/8NPT	100	100	63
	08	1/8-27 NPT	5,0	24,0	18,5	10,0	30	12	14	11	GE08LL1/8NPT	100	100	63
L ³⁾	06	1/8-27 NPT	4,0	24,0	17,0	10,0	32	12	14	12	GE06L1/8NPT	315	315	200
	06	1/4-18 NPT	4,0	30,0	23,0	14,5	38	17	14	27	GE06L1/4NPT	315	315	200
	06	3/8-18 NPT	4,0	30,0	23,0	14,5	38	19	14	32	GE06L3/8NPT	315	315	
	06	1/2-14 NPT	4,0	36,0	29,0	19,5	44	22	14	53	GE06L1/2NPT	315	315	
	08	1/8-27 NPT	4,0	25,0	18,0	10,0	33	14	17	16	GE08L1/8NPT	315	315	
	08	1/4-18 NPT	6,0	30,0	23,0	14,5	38	17	17	25	GE08L1/4NPT	315	315	200
	08	3/8-18 NPT	6,0	30,0	23,0	14,5	38	19	17	34	GE08L3/8NPT	315	315	
	08	1/2-14 NPT	6,0	36,0	29,0	19,5	44	22	17	54	GE08L1/2NPT	315	315	
	10	1/8-27 NPT	4,0	25,0	18,0	10,0	33	17	19	19	GE10L1/8NPT	315	315	
	10	1/4-18 NPT	7,0	31,0	24,0	14,5	39	17	19	25	GE10L1/4NPT	315	315	200
	10	3/8-18 NPT	7,0	32,0	25,0	14,5	40	19	19	40	GE10L3/8NPT	315	315	
	10	1/2-14 NPT	8,0	37,0	30,0	19,5	45	22	19	54	GE10L1/2NPT	315	315	
	10	3/4-14 NPT	8,0	38,0	31,0	19,5	46	30	19	93	GE10L3/4NPT	315	315	
	12	1/8-27 NPT	4,0	26,0	19,0	10,0	34	19	22	52	GE12L1/8NPT	315	315	
	12	1/4-18 NPT	7,0	32,0	25,0	14,5	40	19	22	31	GE12L1/4NPT	315	315	200
	12	3/8-18 NPT	8,0	32,0	25,0	14,5	40	19	22	37	GE12L3/8NPT	315	315	200
	12	1/2-14 NPT	10,0	37,0	30,0	19,5	45	22	22	62	GE12L1/2NPT	315	315	200
	15	3/8-18 NPT	8,0	33,0	26,0	14,5	41	24	27	53	GE15L3/8NPT	315	315	
	15	1/2-14 NPT	12,0	38,0	31,0	19,5	46	24	27	63	GE15L1/2NPT	315	315	200
	15	3/4-14 NPT	12,0	39,0	32,0	19,5	47	30	27	112	GE15L3/4NPT	315	315	
	15	1-11,5 NPT	12,0	45,0	38,0	24,5	53	36	27	158	GE15L1NPT	315	315	
	18	3/8-18 NPT	8,0	34,0	26,5	14,5	43	27	32	69	GE18L3/8NPT	315	315	
	18	1/2-14 NPT	12,0	39,0	31,5	19,5	48	27	32	79	GE18L1/2NPT	315	315	200
	18	3/4-14 NPT	15,0	39,0	31,5	19,5	48	30	32	104	GE18L3/4NPT	315	315	
	18	1-11,5 NPT	15,0	45,0	37,5	24,5	54	36	32	159	GE18L1NPT	315	315	
	22	3/8-18 NPT	8,0	36,5	29,0	14,5	45	32	36	91	GE22L3/8NPT	160	160	
	22	1/2-14 NPT	12,0	41,0	33,5	19,5	50	32	36	96	GE22L1/2NPT	160	160	
	22	3/4-14 NPT	16,0	41,0	33,5	19,5	50	32	36	108	GE22L3/4NPT	160	160	100
	22	1-11,5 NPT	19,0	47,0	39,5	24,5	56	36	36	174	GE22L1NPT	160	160	
	28	3/4-14 NPT	16,0	42,0	34,5	19,5	51	41	41	157	GE28L3/4NPT	160	160	
28	1-11,5 NPT	21,0	47,0	39,5	24,5	56	41	41	197	GE28L1NPT	160	160	100	
28	1 1/4-11,5 NPT	24,0	49,0	41,5	25,0	58	46	41	266	GE28L11/4NPT	160	160		
35	1-11,5 NPT	22,0	50,0	39,5	24,5	61	46	50	280	GE35L1NPT	160	160		
35	1 1/4-11,5 NPT	28,0	51,0	40,5	25,0	62	46	50	285	GE35L11/4NPT	160	160		
42	1 1/4-11,5 NPT	28,0	53,0	42,0	25,0	65	55	60	382	GE42L11/4NPT	160	160		
42	1 1/2-11,5 NPT	36,0	53,0	42,0	26,0	65	55	60	377	GE42L11/2NPT	160	160		

1) Pressione indicata = Articolo disponibile

2) LL = Serie ultraleggera; 3) L = Serie leggera

$$\frac{PN \text{ (bar)}}{10} = PN \text{ (MPa)}$$

Consegna senza dado né anello. Per informazioni sull'ordinazione di raccordi completi vedere pag. 17.

*Aggiungere i suffissi qui di seguito in base al materiale e alla superficie richiesti.

Suffissi codice di ordinazione		
Materiale	Suffisso superficie e materiale	Esempio
Acciaio, zincato, esente da CromoVI	CFX	GE18L1/2NPTCFX
Acciaio inossidabile	71X	GE18L1/2NPT71X
Ottone	MSX	GE18L1/2NPTMSX

GE-NPT Terminale maschio diritto

Filettatura maschio NPT (SAE J476) / Estremità conica EO 24°

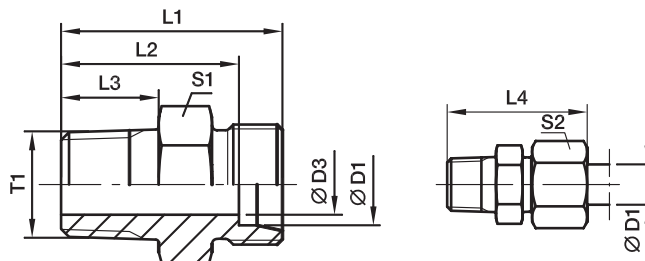

Serie	D1	T1	D3	L1	L2	L3	L4	S1	S2	Peso g/1 pezzo	Codice di ordinazione*	PN (bar) ¹⁾		
												CF	71	MS
S ⁴⁾	06	1/8-27 NPT	4	28	21,0	10,0	36	14	17	21	GE06S1/8NPT	630	630	
	06	1/4-18 NPT	4	35	28,0	14,5	43	17	17	37	GE06S1/4NPT	630	630	400
	06	3/8-18 NPT	4	33	26,0	14,5	41	19	17	40	GE06S3/8NPT	630	630	
	06	1/2-14 NPT	4	42	35,0	19,5	50	22	17	71	GE06S1/2NPT	630	630	
	08	1/4-18 NPT	5	35	28,0	14,5	43	17	19	38	GE08S1/4NPT	630	630	400
	08	3/8-18 NPT	5	35	28,0	14,5	43	19	19	46	GE08S3/8NPT	630	630	
	08	1/2-14 NPT	5	42	35,0	19,5	50	22	19	73	GE08S1/2NPT	630	630	400
	10	1/4-18 NPT	5	35	27,5	14,5	44	19	22	45	GE10S1/4NPT	630	630	
	10	3/8-18 NPT	7	35	27,5	14,5	44	19	22	49	GE10S3/8NPT	630	630	400
	10	1/2-14 NPT	7	42	34,5	19,5	51	22	22	73	GE10S1/2NPT	630	630	400
	10	3/4-14 NPT	7	44	36,5	19,5	53	30	22	125	GE10S3/4NPT	630	630	
	12	1/4-18 NPT	5	37	29,5	14,5	46	22	24	57	GE12S1/4NPT	630	630	
	12	3/8-18 NPT	8	37	29,5	14,5	46	22	24	62	GE12S3/8NPT	630	630	400
	12	1/2-14 NPT	8	42	34,5	19,5	51	22	24	83	GE12S1/2NPT	630	630	400
	12	3/4-14 NPT	8	44	36,5	19,5	53	30	24	126	GE12S3/4NPT	630	630	
	14	3/8-18 NPT	8	39	31,0	14,5	49	24	27	77	GE14S3/8NPT	630	630	
14	1/2-14 NPT	10	44	36,0	19,5	54	24	27	89	GE14S1/2NPT	630	630	400	
14	3/4-14 NPT	10	46	38,0	19,5	56	30	27	130	GE14S3/4NPT	630	630		
14	1-11,5 NPT	10	51	43,0	24,5	61	36	27	180	GE14S1NPT	630	630		
16	3/8-18 NPT	8	39	30,5	14,5	49	27	30	84	GE16S3/8NPT	400	400		
16	1/2-14 NPT	12	48	39,5	19,5	58	32	30	97	GE16S1/2NPT	400	400	250	
16	3/4-14 NPT	12	46	37,5	19,5	56	30	30	130	GE16S3/4NPT	400	400		
16	1-11,5 NPT	12	51	42,5	24,5	61	36	30	178	GE16S1NPT	400	400		
20	1/2-14 NPT	12	48	37,5	19,5	59	32	36	144	GE20S1/2NPT	400	400		
20	3/4-14 NPT	16	48	37,5	19,5	59	32	36	149	GE20S3/4NPT	400	400	250	
20	1-11,5 NPT	16	55	44,5	24,5	66	36	36	243	GE20S1NPT	400	400		
25	3/4-14 NPT	16	52	40,0	19,5	64	41	46	240	GE25S3/4NPT	400	400		
25	1-11,5 NPT	20	57	45,0	24,5	69	41	46	278	GE25S1NPT	400	400		
25	1 1/4-11,5 NPT	20	58	46,0	25,0	70	46	46	396	GE25S11/4NPT	400	400		
25	1 1/2-11,5 NPT	20	61	49,0	26,0	73	50	46	469	GE25S11/2NPT	400	400		
30	3/4-14 NPT	16	54	40,5	19,5	67	46	50	307	GE30S3/4NPT	400	400		
30	1-11,5 NPT	20	59	45,5	24,5	72	46	50	343	GE30S1NPT	400	400	100	
30	1 1/4-11,5 NPT	25	60	46,5	25,0	73	46	50	397	GE30S11/4NPT	400	400		
30	1 1/2-11,5 NPT	25	60	46,5	26,0	73	50	50	440	GE30S11/2NPT	400	400		
38	1-11,5 NPT	22	64	48,0	24,5	79	55	60	510	GE38S1NPT	315	315		
38	1 1/4-11,5 NPT	25	65	49,0	25,0	80	55	60	535	GE38S11/4NPT	315	315		
38	1 1/2-11,5 NPT	32	65	49,0	26,0	80	55	60	571	GE38S11/2NPT	315	315		

¹⁾ Pressione indicata = Articolo disponibile

⁴⁾ S = Serie pesante

PN (bar) = PN (MPa)
10

Consegna senza dado né anello. Per informazioni sull'ordinazione di raccordi completi vedere pag. 17.

*Aggiungere i **suffissi** qui di seguito in base al materiale e alla superficie richiesti.

Suffissi codice di ordinazione		
Materiale	Suffisso superficie e materiale	Esempio
Acciaio, zincato, esente da CromoVI	CFX	GE16S1/2NPTCFX
Acciaio inossidabile	71X	GE16S1/2NPT71X
Ottone	MSX	GE16S1/2NPTMSX

EGEO Raccordo con dado girevole

Filettatura maschio metrica – O-ring (ISO 6149) / Dado girevole EO 24° DKO

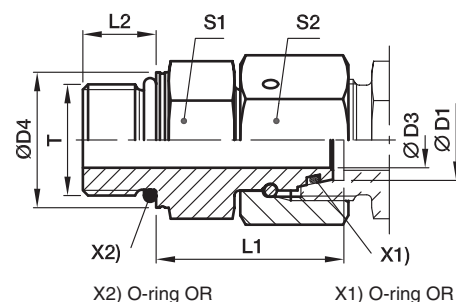

X2) O-ring OR

X1) O-ring OR

Serie	D1 	T	D3	D4	L1	L2	S1	S2	Peso g/1 pezzo	Codice di ordinazione*	PN (bar) ¹⁾ CF
L ³⁾	06	M 10×1,0	2,5	13,8	24,5	8,5	14	14	29	EGEO06LM	500
	08	M 12×1,5	4,0	16,8	26,5	11,0	17	17	43	EGEO08LM	500
	10	M 14×1,5	6,0	18,8	27,5	11,0	19	19	57	EGEO10LM	500
	12	M 16×1,5	8,0	21,8	30,5	11,5	22	22	85	EGEO12LM	400
	15	M 18×1,5	10,0	23,8	31,5	12,5	24	27	115	EGEO15LM	400
	18	M 22×1,5	13,0	26,8	31,5	13,0	27	32	152	EGEO18LM	400
	22	M 27×2,0	17,0	31,8	32,5	16,0	32	36	207	EGEO22LM27X2	250
	28	M 33×2,0	22,0	40,8	35,0	16,0	41	41	294	EGEO28LM	250
	35	M 42×2,0	28,0	49,8	42,5	16,0	50	50	516	EGEO35LM	250
	42	M 48×2,0	34,0	54,8	46,5	17,5	55	60	718	EGEO42LM	250
S ⁴⁾	06	M 12×1,5	2,5	16,8	27,0	11,0	17	17	49	EGEO06SM	800
	08	M 14×1,5	4,0	18,8	29,5	11,0	19	19	69	EGEO08SM	800
	10	M 16×1,5	6,0	21,8	32,0	12,5	22	22	96	EGEO10SM	800
	12	M 18×1,5	8,0	23,8	34,0	14,0	24	24	116	EGEO12SM	630
	16	M 22×1,5	11,0	26,8	37,0	15,0	27	30	179	EGEO16SM	630
	20	M 27×2,0	14,0	31,8	43,0	18,5	32	36	280	EGEO20SM	420
	25	M 33×2,0	18,0	40,8	48,0	18,5	41	46	502	EGEO25SM	420
	30	M 42×2,0	23,0	49,8	51,0	19,0	50	50	697	EGEO30SM	420
	38	M 48×2,0	30,0	54,8	60,0	21,5	55	60	965	EGEO38SM	420

¹⁾ Pressione indicata = Articolo disponibile

³⁾ L = Serie leggera; ⁴⁾ S = Serie pesante

$$\frac{\text{PN (bar)}}{10} = \text{PN (MPa)}$$

Per informazioni sull'ordinazione di raccordi completi vedere pag. 17.

Suffissi codice di ordinazione			
Materiale	Suffisso superficie e materiale	Esempio	Materiale di tenuta standard (non occorre suffisso aggiuntivo)
Acciaio, zincato, esente da CromoVI	CF	EGEO16SMCF	NBR

*Aggiungere i **suffissi** qui di seguito in base al materiale e alla superficie richiesti.

EGE-M-ED Raccordo con dado girevole

Filettatura maschio metrica – Guarnizione ED (ISO 9974) / Dado girevole EO 24° DKO

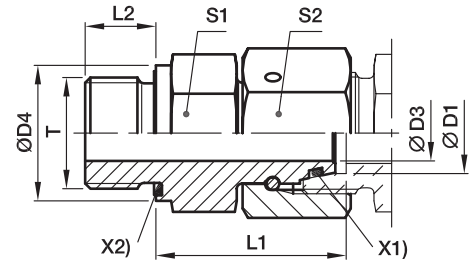

X2) Guarnizione Eolastic ED X1) O-ring OR

Serie	D1 	T	D3	D4	L1	L2	S1	S2	Peso g/1 pezzo	Codice di ordinazione*	PN (bar) ¹⁾		
											CF	71	
L ³⁾	06	M 10x1,0	2,5	14	24,5	8	14	14	27	EGE06LMED	500	315	
	08	M 12x1,5	4,0	17	26,5	12	17	17	45	EGE08LMED	500	315	
	10	M 14x1,5	6,0	19	27,5	12	19	19	57	EGE10LMED	500	315	
	12	M 16x1,5	8,0	22	30,5	12	22	22	82	EGE12LMED	400	315	
	12	M 22x1,5	8,0	27	27,0	14	27	22	92	EGE12LM22X1,5ED	400	315	
	15	M 18x1,5	10,0	24	31,5	12	24	27	113	EGE15LMED	400	315	
	15	M 22x1,5	10,0	27	32,0	14	27	27	142	EGE15LM22X1,5ED	400	315	
	18	M 22x1,5	13,0	27	31,5	14	27	32	148	EGE18LMED	400	315	
	22	M 26x1,5	17,0	32	32,5	16	32	36	203	EGE22LMED	250	160	
	28	M 33x2,0	22,0	40	35,0	18	41	41	289	EGE28LMED	250	160	
	35	M 42x2,0	28,0	50	42,5	20	50	50	511	EGE35LMED	250	160	
	42	M 48x2,0	34,0	55	46,5	22	55	60	711	EGE42LMED	250	160	
	S ⁴⁾	06	M 12x1,5	2,5	17	27,0	12	17	17	47	EGE06SMED	800	630
		08	M 14x1,5	4,0	19	29,5	12	19	19	65	EGE08SMED	800	630
10		M 16x1,5	6,0	22	32,0	12	22	22	91	EGE10SMED	800	630	
12		M 18x1,5	8,0	24	34,0	12	24	24	112	EGE12SMED	630	630	
14		M 20x1,5	9,0	26	36,5	14	27	27	153	EGE14SMED	630	630	
16		M 22x1,5	11,0	27	37,0	14	27	30	174	EGE16SMED	630	400	
20		M 27x2,0	14,0	32	43,0	16	32	36	274	EGE20SMED	420	400	
25		M 33x2,0	18,0	40	48,0	18	41	46	497	EGE25SMED	420	400	
30		M 42x2,0	23,0	50	51,0	20	50	50	691	EGE30SMED	420	400	
38		M 48x2,0	30,0	55	60,0	22	55	60	957	EGE38SMED	420	315	

¹⁾ Pressione indicata = Articolo disponibile

³⁾ L = Serie leggera; ⁴⁾ S = Serie pesante

$$\frac{\text{PN (bar)}}{10} = \text{PN (MPa)}$$

Per informazioni sull'ordinazione di raccordi completi vedere pag. 17.

Suffissi codice di ordinazione			
Materiale	Suffisso superficie e materiale	Esempio	Materiale di tenuta standard (non occorre suffisso aggiuntivo)
Acciaio, zincato, esente da CromoVI	CF	EGE16SMEDCF	NBR
Acciaio inossidabile	71	EGE16SMED71	VIT

*Aggiungere i **suffissi** qui di seguito in base al materiale e alla superficie richiesti.

EGE-R-ED Raccordo con dado girevole

Filettatura maschio BSPP – Guarnizione ED (ISO 1179) / Dado girevole EO 24° DKO

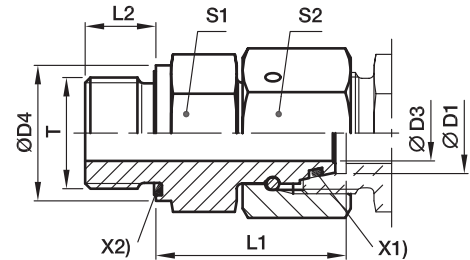

X2) Guarnizione Eolastic ED X1) O-ring OR

Serie	D1	T	D3	D4	L1	L2	S1	S2	Peso g/1 pezzo	Codice di ordinazione*	PN (bar) ¹⁾	
											CF	71
L ³⁾	06	G 1/8 A	2,5	14	24,5	8	14	14	27	EGE06LRED	500	315
	08	G 1/4 A	4,0	19	29,5	12	19	17	28	EGE08LRED	500	315
	10	G 1/4 A	6,0	19	27,5	12	19	19	54	EGE10LRED	500	315
	10	G 3/8 A	6,0	22	29,0	12	22	19	70	EGE10LR3/8ED	400	
	12	G 3/8 A	8,0	22	34,0	12	22	22	95	EGE12LRED	400	315
	12	G 1/4 A	6,0	19	27,5	12	19	22	65	EGE12LR1/4ED	400	
	12	G 1/2 A	8,0	27	29,5	14	27	22	114	EGE12LR1/2ED	400	
	15	G 1/2 A	10,0	27	32,0	14	27	27	137	EGE15LRED	400	315
	18	G 1/2 A	13,0	27	31,5	14	27	32	143	EGE18LRED	400	315
	18	G 3/4 A	13,0	32	29,5	16	32	32	182	EGE18LR3/4ED	250	
	22	G 3/4 A	17,0	32	32,5	16	32	36	200	EGE22LRED	250	160
	28	G 1 A	22,0	40	35,0	18	41	41	289	EGE28LRED	250	160
	35	G 1 1/4 A	28,0	50	42,5	20	50	50	500	EGE35LRED	250	160
	42	G 1 1/2 A	34,0	55	46,5	22	55	60	718	EGE42LRED	250	160
	S ⁴⁾	06	G 1/4 A	2,5	19	27,0	12	19	17	53	EGE06SRED	800
08		G 1/4 A	4,0	19	29,5	12	19	19	64	EGE08SRED	800	630
10		G 3/8 A	6,0	22	32,0	12	22	22	93	EGE10SRED	800	630
12		G 3/8 A	8,0	22	34,0	12	22	24	100	EGE12SRED	630	630
12		G 1/4 A	5,0	19	31,5	12	19	24	140	EGE12SR1/4ED	630	
12		G 1/2 A	8,0	27	35,0	14	27	24	140	EGE12SR1/2ED	630	630
14		G 1/2 A	9,0	27	36,5	14	27	27	157	EGE14SRED	630	630
16		G 1/2 A	11,0	27	37,0	14	27	30	170	EGE16SRED	630	400
20		G 3/4 A	14,0	32	43,0	16	32	36	273	EGE20SRED	420	400
25		G 1 A	18,0	40	48,0	18	41	46	493	EGE25SRED	420	400
30		G 1 1/4 A	23,0	50	51,0	20	50	50	691	EGE30SRED	420	
38		G 1 1/2 A	30,0	55	60,0	22	55	60	934	EGE38SRED	420	315

¹⁾ Pressione indicata = Articolo disponibile

³⁾ L = Serie leggera; ⁴⁾ S = Serie pesante

$$\frac{PN(\text{bar})}{10} = PN(\text{MPa})$$

Per informazioni sull'ordinazione di raccordi completi vedere pag. I7.

Suffissi codice di ordinazione			
Materiale	Suffisso superficie e materiale	Esempio	Materiale di tenuta standard (non occorre suffisso aggiuntivo)
Acciaio, zincato, esente da CromoVI	CF	EGE16SREDCF	NBR
Acciaio inossidabile	71	EGE16SRED71	VIT

*Aggiungere i **suffissi** qui di seguito in base al materiale e alla superficie richiesti.

EVGE-M-ED Raccordo per codolo

Filettatura maschio metrica – ED (ISO 9974) / Codolo EO orientabile

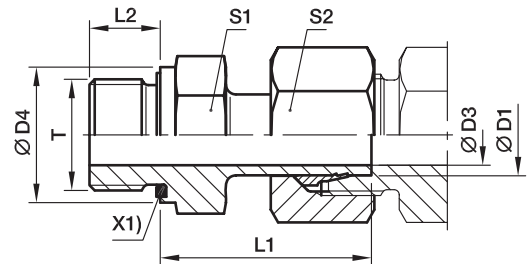

Con dado e anello premontati. Montaggio finale (in apposito corpo) almeno 1/4 di giro oltre il punto di resistenza chiaramente percepibile.

X1) Guarnizione Eolastic ED

Serie	D1 	T	D3	D4	L1	L2	S1	S2	Peso g/1 pezzo	Codice di ordinazione*	PN (bar) ¹⁾	
											CF	71
L ³⁾	06	M 10x1,0	3,5	14	24,5	8	14	14	24	EVGE06LMED	315	315
	08	M 12x1,5	5,5	17	26,5	12	17	17	38	EVGE08LMED	315	315
	10	M 14x1,5	7,0	19	27,5	12	19	19	49	EVGE10LMED	315	315
	12	M 16x1,5	9,0	22	30,0	12	22	22	67	EVGE12LMED	315	315
	15	M 18x1,5	11,0	24	30,5	12	24	27	95	EVGE15LMED	315	315
	18	M 22x1,5	14,0	27	31,5	14	27	32	137	EVGE18LMED	315	315
	22	M 26x1,5	18,0	32	32,5	16	32	36	183	EVGE22LMED	160	160
	28	M 33x2,0	23,0	40	35,0	18	41	41	264	EVGE28LMED	160	160
	35	M 42x2,0	29,5	50	42,5	20	50	50	444	EVGE35LMED	160	160
	42	M 48x2,0	35,5	55	46,5	22	55	60	614	EVGE42LMED	160	160
S ⁴⁾	06	M 12x1,5	3,5	17	27,0	12	17	17	43	EVGE06SMED	630	630
	08	M 14x1,5	4,5	19	29,5	12	19	19	59	EVGE08SMED	630	630
	10	M 16x1,5	6,5	22	32,0	12	22	22	82	EVGE10SMED	630	630
	12	M 18x1,5	7,5	24	34,0	12	24	24	104	EVGE12SMED	630	630
	14	M 20x1,5	9,5	26	36,5	14	27	27	144	EVGE14SMED	630	630
	16	M 22x1,5	11,5	27	37,0	14	27	30	162	EVGE16SMED	400	400
	20	M 27x2,0	15,5	32	43,0	16	32	36	254	EVGE20SMED	400	400
	25	M 33x2,0	18,0	40	48,0	18	41	46	493	EVGE25SMED	400	400
	30	M 42x2,0	23,5	50	51,0	20	50	50	654	EVGE30SMED	400	400
	38	M 48x2,0	29,0	55	60,0	22	55	60	962	EVGE38SMED	315	315

¹⁾ Pressione indicata = Articolo disponibile

³⁾ L = Serie leggera; ⁴⁾ S = Serie pesante

$\frac{PN(\text{bar})}{10} = PN(\text{MPa})$

Per informazioni sull'ordinazione di raccordi completi vedere pag. I7.

Suffissi codice di ordinazione			
Materiale	Suffisso superficie e materiale	Esempio	Materiale di tenuta standard (non occorre suffisso aggiuntivo)
Acciaio, zincato, esente da CromoVI	CF	EGE16SMEDCF	NBR
Acciaio inossidabile	71	EGE16SMED71	VIT

*Aggiungere i **suffissi** qui di seguito in base al materiale e alla superficie richiesti.

EVGE-R-ED Raccordo per codolo

Filettatura maschio BSPP – Guarnizione ED (ISO 1179) / Codolo EO orientabile

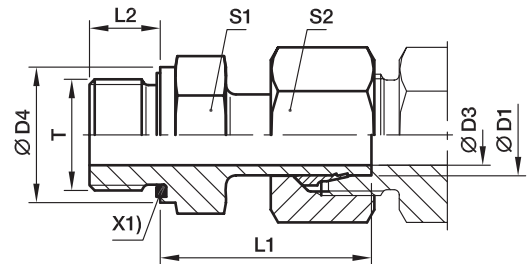

Con dado e anello premontati. Montaggio finale (in apposito corpo) almeno 1/4 di giro oltre il punto di resistenza chiaramente percepibile.

X1) Guarnizione Eolastic ED

Serie	D1	T	D3	D4	L1	L2	S1	S2	Peso g/1 pezzo	Codice di ordinazione*	PN (bar) ¹⁾		
											CF	71	MS
L ³⁾	06	G 1/8 A	3,5	14	24,5	8	14	14	24	EVGE06LR ED	315	315	200
	08	G 1/4 A	4,5	19	29,5	12	19	17	52	EVGE08LR ED	315	315	200
	10	G 1/4 A	7,0	19	27,5	12	19	19	47	EVGE10LR ED	315	315	200
	12	G 3/8 A	7,5	22	34,0	12	22	22	87	EVGE12LR ED	315	315	200
	12	G 1/4 A	7,0	19	28,5	12	19	22	61	EVGE12LR1/4ED	315		
	12	G 1/2 A	7,5	27	34,5	14	27	22	121	EVGE12LR1/2ED	315	315	
	15	G 1/2 A	11,0	27	31,0	14	27	27	114	EVGE15LR ED	315	315	200
	18	G 1/2 A	14,0	27	31,5	14	27	32	132	EVGE18LR ED	315	315	200
	22	G 3/4 A	18,0	32	32,5	16	32	36	183	EVGE22LR ED	160	160	100
	28	G 1 A	23,0	40	35,0	18	41	41	262	EVGE28LR ED	160	160	
S ⁴⁾	35	G 1 1/4 A	29,5	50	42,5	20	50	50	436	EVGE35LR ED	160	160	
	42	G 1 1/2 A	35,5	55	46,5	22	55	60	615	EVGE42LR ED	160	160	
	06	G 1/4 A	3,5	19	27,0	12	19	17	48	EVGE06SR ED	630	630	
	08	G 1/4 A	4,5	19	29,5	12	19	19	57	EVGE08SR ED	630	630	
	10	G 3/8 A	6,5	22	32,0	12	22	22	84	EVGE10SR ED	630	630	
	12	G 3/8 A	7,5	22	34,0	12	22	24	95	EVGE12SR ED	630	630	
	12	G 1/2 A	7,5	27	34,5	14	27	24	130	EVGE12SR1/2ED	630	630	
	14	G 1/2 A	9,5	27	36,5	14	27	27	149	EVGE14SR ED	630	630	
	16	G 1/2 A	11,5	27	37,0	14	27	30	158	EVGE16SR ED	400	400	
	16	G 3/4 A	11,5	32	39,0	16	32	30	222	EVGE16SR3/4ED	400		
	20	G 3/4 A	15,5	32	43,0	16	32	36	254	EVGE20SR ED	400	400	
	25	G 1 A	18,0	40	48,0	18	41	46	485	EVGE25SR ED	400	400	
	30	G 1 1/4 A	23,5	50	51,0	20	50	50	661	EVGE30SR ED	400	400	
	38	G 1 1/2 A	29,0	55	60,0	22	55	60	962	EVGE38SR ED	315	315	

1) Pressione indicata = Articolo disponibile

3) L = Serie leggera; 4) S = Serie pesante

PN (bar) = PN (MPa)

10

Per informazioni sull'ordinazione di raccordi completi vedere pag. I7.

Suffissi codice di ordinazione			
Materiale	Suffisso superficie e materiale	Esempio	Materiale di tenuta standard (non occorre suffisso aggiuntivo)
Acciaio, zincato, esente da CromoVI	CF	EVGE16SREDCF	NBR
Acciaio inossidabile	71	EVGE16SRED71	VIT
Ottone	MS	EVGE16SREDMS	NBR

*Aggiungere i **suffissi** qui di seguito in base al materiale e alla superficie richiesti.

EGE-NPT Raccordo con dado girevole

Filettatura maschio NPT (SAE J476) / Dado girevole EO 24° DKO

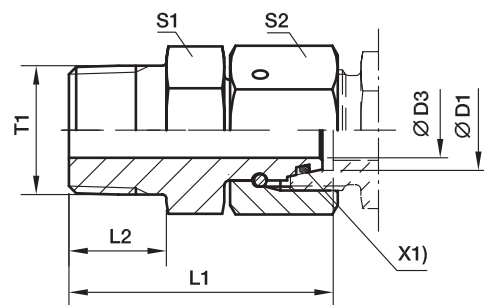

X1) O-ring OR

Serie	D1 	T1	D3	L1	L2	S1	S2	Peso g/1 pezzo	Codice di ordinazione*	PN (bar) ¹⁾
										CF
L ³⁾	06	1/8-27 NPT	2,5	31,5	10,0	11	14	23	EGE06L1/8NPT	315
	08	1/4-18 NPT	4,0	37,5	14,5	14	17	41	EGE08L1/4NPT	315
	10	1/4-18 NPT	6,0	38,0	14,5	14	19	44	EGE10L1/4NPT	315
	12	3/8-18 NPT	8,0	40,0	14,5	19	22	69	EGE12L3/8NPT	315
	15	1/2-14 NPT	10,0	49,5	19,5	22	27	127	EGE15L1/2NPT	315
	18	1/2-14 NPT	12,0	49,0	19,5	24	32	142	EGE18L1/2NPT	315
	22	3/4-14 NPT	16,0	52,0	19,5	27	36	200	EGE22L3/4NPT	160
	28	1-11,5 NPT	22,0	61,0	24,5	36	41	306	EGE28L1NPT	160
	35	1 1/4-11,5 NPT	28,0	65,5	25,0	46	50	486	EGE35L11/4NPT	160
	42	1 1/2-11,5 NPT	34,0	68,5	26,0	50	60	662	EGE42L11/2NPT	160
S ⁴⁾	06	1/4-18 NPT	2,5	37,5	14,5	14	17	42	EGE06S1/4NPT	630
	08	1/4-18 NPT	4,0	38,0	14,5	14	19	47	EGE08S1/4NPT	630
	10	3/8-18 NPT	6,0	40,5	14,5	19	22	75	EGE10S3/8NPT	630
	12	3/8-18 NPT	8,0	42,0	14,5	19	24	81	EGE12S3/8NPT	630
	14	1/2-14 NPT	9,0	50,5	19,5	22	27	131	EGE14S1/2NPT	630
	16	1/2-14 NPT	11,0	51,0	19,5	22	30	145	EGE16S1/2NPT	400
	20	3/4-14 NPT	14,0	54,0	19,5	27	36	221	EGE20S3/4NPT	400
	25	1-11,5 NPT	18,0	63,5	24,5	36	46	422	EGE25S1NPT	400
	30	1 1/4-11,5 NPT	23,0	70,5	25,0	46	50	628	EGE30S11/4NPT	400
	38	1 1/2-11,5 NPT	30,0	73,5	26,0	50	60	770	EGE38S11/2NPT	315

¹⁾ Pressione indicata = Articolo disponibile

³⁾ L = Serie leggera; ⁴⁾ S = Serie pesante

$\frac{PN(\text{bar})}{10} = PN(\text{MPa})$

Per informazioni sull'ordinazione di raccordi completi vedere pag. I7.

Suffissi codice di ordinazione			
Materiale	Suffisso superficie e materiale	Esempio	Materiale di tenuta standard (non occorre suffisso aggiuntivo)
Acciaio, zincato, esente da CromoVI	CF	EGE16S1/2NPTCF	NBR

*Aggiungere i **suffissi** qui di seguito in base al materiale e alla superficie richiesti.

EW-M-ED Gomito orientabile con dado girevole assemblato

Estremità conica EO 24° / Filettatura maschio metrica – Guarnizione ED (ISO 9974)

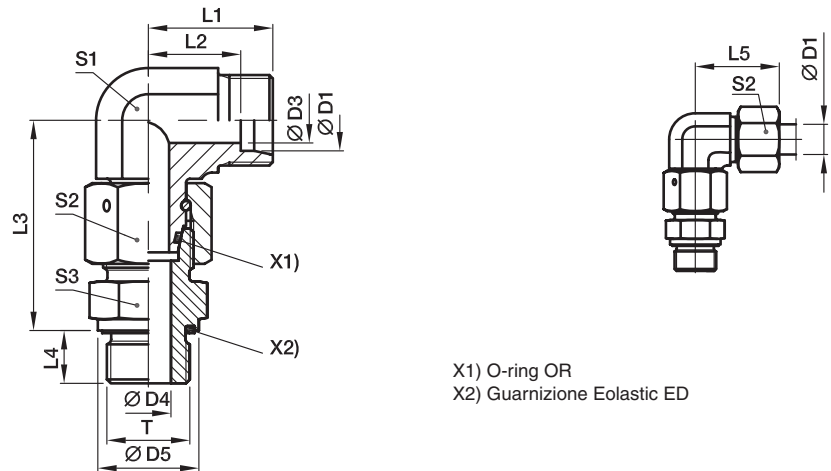

X1) O-ring OR
X2) Guarnizione Eolastic ED

Serie	D1	T	D3	D4	D5	L1	L2	L3	L4	L5	S1	S2	S3	Peso g/1 pezzo	Codice di ordinazione*	PN (bar) ¹⁾	
																CF	71
L ³⁾	06	M 10×1,0	4	4	14	19	12,0	34,5	8	27	12	14	14	47	EW06LMEDOMD	500	315
	08	M 12×1,5	6	6	17	21	14,0	37,5	12	29	12	17	17	69	EW08LMEDOMD	500	315
	10	M 14×1,5	8	7	19	22	15,0	40,0	12	30	14	19	19	87	EW10LMEDOMD	500	315
	12	M 16×1,5	10	9	22	24	17,0	42,0	12	32	17	22	22	111	EW12LMEDOMD	400	315
	15	M 18×1,5	12	11	24	28	21,0	46,0	12	36	19	27	24	179	EW15LMEDOMD	400	315
	18	M 22×1,5	15	14	27	31	23,5	50,0	14	40	24	32	27	272	EW18LMEDOMD	400	315
	22	M 26×1,5	19	18	32	35	27,5	55,0	16	44	27	36	32	360	EW22LMEDOMD	250	160
	28	M 33×2,0	24	23	40	38	30,5	59,0	18	47	36	41	41	538	EW28LMEDOMD	250	160
	35	M 42×2,0	30	30	50	45	34,5	68,5	20	56	41	50	50	843	EW35LMEDOMD	250	160
	42	M 48×2,0	36	36	55	51	40,0	75,0	22	63	50	60	55	1353	EW42LMEDOMD	250	160
S ⁴⁾	06	M 12×1,5	4	4	17	23	16,0	40,0	12	31	12	17	17	77	EW06SMEDOMD	800	630
	08	M 14×1,5	5	5	19	24	17,0	42,5	12	32	14	19	19	107	EW08SMEDOMD	800	630
	10	M 16×1,5	6	7	22	25	17,5	45,0	12	34	17	22	22	146	EW10SMEDOMD	800	630
	12	M 18×1,5	8	8	24	29	21,5	48,0	12	38	17	24	24	178	EW12SMEDOMD	630	630
	14	M 20×1,5	9	10	26	30	22,0	54,0	14	40	19	27	27	203	EW14SMEDOMD	630	630
	16	M 22×1,5	12	12	27	33	24,5	55,0	14	43	24	30	27	307	EW16SMEDOMD	630	400
	20	M 27×2,0	16	16	32	37	26,5	65,0	16	48	27	36	32	459	EW20SMEDOMD	420	400
	25	M 33×2,0	20	20	40	42	30,0	73,0	18	54	36	46	41	812	EW25SMEDOMD	420	400
	30	M 42×2,0	25	25	50	49	35,5	78,5	20	62	41	50	50	1167	EW30SMEDOMD	420	400
	38	M 48×2,0	32	32	55	57	41,0	89,0	22	72	50	60	55	1790	EW38SMEDOMD	420	315

¹⁾ Pressione indicata = Articolo disponibile

³⁾ L = Serie leggera; ⁴⁾ S = Serie pesante

$$\frac{PN \text{ (bar)}}{10} = PN \text{ (MPa)}$$

Consegna senza dado né anello. Per informazioni sull'ordinazione di raccordi completi o sui materiali di tenuta alternativi vedere pag. 17.

Suffissi codice di ordinazione			
Materiale	Suffisso superficie e materiale	Esempio	Materiale di tenuta standard (non occorre suffisso aggiuntivo)
Acciaio, zincato, esente da CromoVI	CF	EW16SMEDOMDCF	NBR
Acciaio inossidabile	71	EW16SMEDOMD71	VIT

*Aggiungere i suffissi qui di seguito in base al materiale e alla superficie richiesti.

EW-R-ED Gomito orientabile con dado girevole assemblato

Estremità conica EO 24° / Filettatura maschio BSPP – Guarnizione ED (ISO 1179)

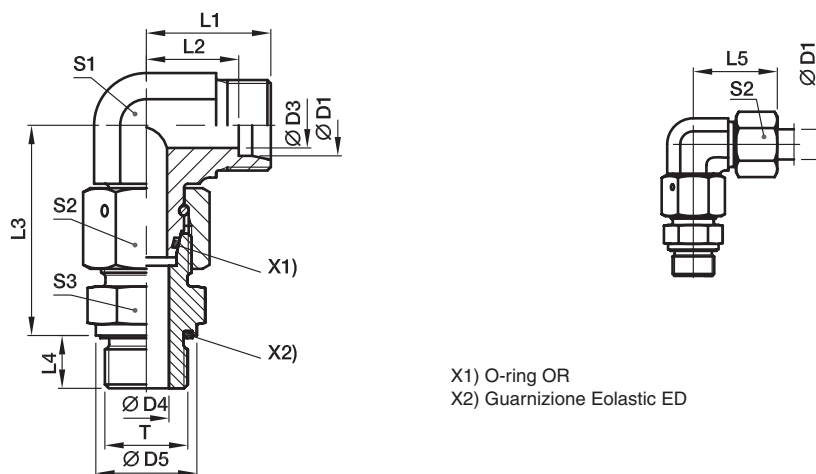

X1) O-ring OR
X2) Guarnizione Eolastic ED

Serie	D1	T	D3	D4	D5	L1	L2	L3	L4	L5	S1	S2	S3	Peso g/1 pezzo	Codice di ordinazione*	PN (bar) ¹⁾	
																CF	71
L3)	06	G 1/8 A	4	4	14	19	12,0	34,5	8	27	12	14	14	47	EW06LREDOMD	500	315
	08	G 1/4 A	6	6	19	21	14,0	37,5	12	29	12	17	19	69	EW08LREDOMD	500	315
	10	G 1/4 A	8	6	19	22	15,0	40,0	12	30	14	19	19	87	EW10LREDOMD	500	315
	12	G 3/8 A	10	9	22	24	17,0	42,0	12	32	17	22	22	122	EW12LREDOMD	400	315
	15	G 1/2 A	12	11	27	28	21,0	46,5	14	36	19	27	27	199	EW15LREDOMD	400	315
	18	G 1/2 A	15	14	27	31	23,5	50,0	14	40	24	32	27	268	EW18LREDOMD	400	315
	22	G 3/4 A	19	18	32	35	27,5	55,0	16	44	27	36	32	360	EW22LREDOMD	250	160
	28	G 1 A	24	23	40	38	30,5	59,0	18	47	36	41	41	539	EW28LREDOMD	250	160
	35	G 1 1/4 A	30	30	50	45	34,5	68,5	20	56	41	50	50	834	EW35LREDOMD	250	160
	42	G 1 1/2 A	36	36	55	51	40,0	75,0	22	63	50	60	55	1341	EW42LREDOMD	250	160
S4)	06	G 1/4 A	4	4	19	23	16,0	40,0	12	31	12	17	19	83	EW06SREDOMD	800	630
	08	G 1/4 A	5	5	19	24	17,0	42,5	12	32	14	19	19	106	EW08SREDOMD	800	630
	10	G 3/8 A	6	7	22	25	17,5	45,0	12	34	17	22	22	148	EW10SREDOMD	800	630
	12	G 3/8 A	8	8	22	29	21,5	48,0	12	38	17	24	22	170	EW12SREDOMD	630	630
	14	G 1/2 A	9	10	27	30	22,0	54,0	14	40	19	27	27	242	EW14SREDOMD	630	630
	16	G 1/2 A	12	12	27	33	24,5	55,0	14	43	24	30	27	303	EW16SREDOMD	630	400
	20	G 3/4 A	16	16	32	37	26,5	65,0	16	48	27	36	32	458	EW20SREDOMD	420	400
	25	G 1 A	20	20	40	42	30,0	73,0	18	54	36	46	41	813	EW25SREDOMD	420	400
	30	G 1 1/4 A	25	25	50	49	35,5	78,5	20	62	41	50	50	1163	EW30SREDOMD	420	400
	38	G 1 1/2 A	32	32	55	57	41,0	89,0	22	72	50	60	55	1784	EW38SREDOMD	420	315

¹⁾ Pressione indicata = Articolo disponibile

³⁾ L = Serie leggera; ⁴⁾ S = Serie pesante

PN (bar) = PN (MPa)
10

Consegna senza dado né anello. Per informazioni sull'ordinazione di raccordi completi o sui materiali di tenuta alternativi vedere pag. 17.

Suffissi codice di ordinazione			
Materiale	Suffisso superficie e materiale	Esempio	Materiale di tenuta standard (non occorre suffisso aggiuntivo)
Acciaio, zincato, esente da CromoVI	CF	EW16SREDOMDCF	NBR
Acciaio inossidabile	71	EW16SREDOMD71	VIT

*Aggiungere i **suffissi** qui di seguito in base al materiale e alla superficie richiesti.

EV-M-ED Gomito 45° orientabile con dado girevole assemblato

Estremità conica EO 24° / Filettatura maschio metrica – Guarnizione ED (ISO 9974)

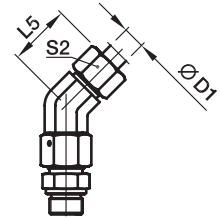
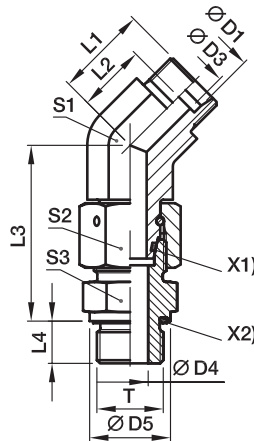

X1) O-ring OR
X2) Guarnizione Elastica ED

Serie	D1	T	D3	D4	D5	L1	L2	L3	L4	L5	S1	S2	S3	Peso g/1 pezzo	Codice di ordinazione*	PN (bar) ¹⁾	
																CF	71
L ³⁾	06	M 10x1,0	4	4	14	16,0	9,0	34,5	8	24	14	14	14	44	EV06LMEDOMD	315	315
	08	M 12x1,5	6	6	17	19,0	12,0	37,5	12	27	14	17	17	62	EV08LMEDOMD	315	315
	10	M 14x1,5	8	7	19	19,0	12,0	40,0	12	27	19	19	19	80	EV10LMEDOMD	315	315
	12	M 16x1,5	10	9	22	21,0	14,0	42,0	12	29	19	22	22	110	EV12LMEDOMD	315	315
	15	M 18x1,5	12	11	24	24,0	17,0	46,0	12	32	22	27	24	171	EV15LMEDOMD	315	315
	18	M 22x1,5	15	14	27	24,0	16,5	50,0	14	33	27	32	27	245	EV18LMEDOMD	315	315
	22	M 26x1,5	19	18	32	26,0	18,5	55,0	16	35	30	36	32	339	EV22LMEDOMD	160	160
	28	M 33x2,0	24	23	40	30,5	23,0	59,0	18	40	36	41	41	517	EV28LMEDOMD	160	160
	35	M 42x2,0	30	30	50	37,0	26,5	68,5	20	48	50	50	50	810	EV35LMEDOMD	160	160
	42	M 48x2,0	36	36	55	37,0	26,0	75,0	22	49	50	60	55	1193	EV42LMEDOMD	160	160
S ⁴⁾	06	M 12x1,5	4	4	17	16,0	9,0	40,0	12	24	14	17	17	72	EV06SMEDOMD	630	630
	08	M 14x1,5	5	5	19	19,0	12,0	42,5	12	27	19	19	19	102	EV08SMEDOMD	630	630
	10	M 16x1,5	7	7	22	21,0	13,5	45,0	12	30	19	22	22	132	EV10SMEDOMD	630	630
	12	M 18x1,5	8	8	24	24,0	16,5	48,0	12	33	22	24	24	173	EV12SMEDOMD	630	630
	16	M 22x1,5	12	12	27	24,0	15,5	55,0	14	34	27	30	27	284	EV16SMEDOMD	400	400
	20	M 27x2,0	16	16	32	26,5	16,0	65,0	16	38	30	36	32	435	EV20SMEDOMD	400	400
	25	M 33x2,0	20	20	40	30,5	18,5	73,0	18	43	36	46	41	790	EV25SMEDOMD	400	400
	30	M 42x2,0	25	25	50	37,0	23,5	78,5	20	50	50	50	50	1132	EV30SMEDOMD	400	400
	38	M 48x2,0	32	32	55	37,0	21,0	89,0	22	52	50	60	55	1631	EV38SMEDOMD	315	315

¹⁾ Pressione indicata = Articolo disponibile

³⁾ L = Serie leggera; ⁴⁾ S = Serie pesante

$$\frac{PN \text{ (bar)}}{10} = PN \text{ (MPa)}$$

Consegna senza dado né anello. Per informazioni sull'ordinazione di raccordi completi o sui materiali di tenuta alternativi vedere pag. 17.

Suffissi codice di ordinazione			
Materiale	Suffisso superficie e materiale	Esempio	Materiale di tenuta standard (non occorre suffisso aggiuntivo)
Acciaio, zincato, esente da CromoVI	CF	EV16SMEDOMDCF	NBR
Acciaio inossidabile	71	EV16SMEDOMD71	VIT

*Aggiungere i suffissi qui di seguito in base al materiale e alla superficie richiesti.

EV-R-ED Gomito 45° orientabile con dado girevole assemblato

Estremità conica EO 24° / Filettatura maschio BSPP – Guarnizione ED (ISO 1179)

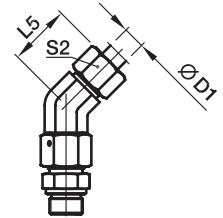
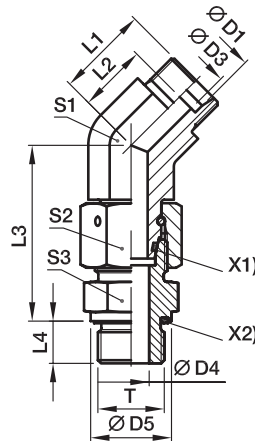

X1) O-ring OR
X2) Guarnizione Eolastic ED

Serie	D1	T	D3	D4	D5	L1	L2	L3	L4	L5	S1	S2	S3	Peso g/1 pezzo	Codice di ordinazione*	PN (bar) ¹⁾	
																CF	71
L ³⁾	06	G 1/8 A	4	4	14	16,0	9,0	34,5	8	24	14	14	14	44	EV06LREDOMD	315	315
	08	G 1/4 A	6	6	19	19,0	12,0	37,5	12	27	14	17	19	67	EV08LREDOMD	315	315
	10	G 1/4 A	8	6	19	19,0	12,0	40,0	12	27	19	19	19	78	EV10LREDOMD	315	315
	12	G 3/8 A	10	9	22	21,0	14,0	42,0	12	29	19	22	22	112	EV12LREDOMD	315	315
	15	G 1/2 A	12	11	27	24,0	17,0	46,5	14	32	22	27	27	192	EV15LREDOMD	315	315
	18	G 1/2 A	15	14	27	24,0	16,5	50,0	14	33	27	32	27	242	EV18LREDOMD	315	315
	22	G 3/4 A	19	18	32	26,0	18,5	55,0	16	35	30	36	32	338	EV22LREDOMD	160	160
	28	G 1 A	24	23	40	30,5	23,0	59,0	18	40	36	41	41	518	EV28LREDOMD	160	160
	35	G 1 1/4 A	30	30	50	37,0	26,5	68,5	20	48	50	50	50	801	EV35LREDOMD	160	160
	42	G 1 1/2 A	36	36	55	37,0	26,0	75,0	22	49	50	60	55	1181	EV42LREDOMD	160	160
S ⁴⁾	06	G 1/4 A	4	4	19	16,0	9,0	40,0	12	24	14	17	19	78	EV06SREDOMD	630	630
	08	G 1/4 A	5	5	19	19,0	12,0	42,5	12	27	19	19	19	101	EV08SREDOMD	630	630
	10	G 3/8 A	7	7	22	21,0	13,5	45,0	12	30	19	22	22	134	EV10SREDOMD	630	630
	12	G 3/8 A	8	8	22	24,0	16,5	48,0	12	33	22	24	22	165	EV12SREDOMD	630	630
	16	G 1/2 A	12	12	27	24,0	15,5	55,0	14	34	27	30	27	280	EV16SREDOMD	400	400
	20	G 3/4 A	16	16	32	26,5	16,0	65,0	16	38	30	36	32	434	EV20SREDOMD	400	400
	25	G 1 A	20	20	40	30,5	18,5	73,0	18	43	36	46	41	792	EV25SREDOMD	400	400
	30	G 1 1/4 A	25	25	50	37,0	23,5	78,5	20	50	50	50	50	1128	EV30SREDOMD	400	400
	38	G 1 1/2 A	32	32	55	37,0	21,0	89,0	22	52	50	60	55	1625	EV38SREDOMD	315	315

¹⁾ Pressione indicata = Articolo disponibile

³⁾ L = Serie leggera; ⁴⁾ S = Serie pesante

$$\frac{PN \text{ (bar)}}{10} = PN \text{ (MPa)}$$

Consegna senza dado né anello. Per informazioni sull'ordinazione di raccordi completi o sui materiali di tenuta alternativi vedere pag. 17.

Suffissi codice di ordinazione			
Materiale	Suffisso superficie e materiale	Esempio	Materiale di tenuta standard (non occorre suffisso aggiuntivo)
Acciaio, zincato, esente da CromoVI	CF	EV16SREDOMDCF	NBR
Acciaio inossidabile	71	EV16SREDOMD71	VIT

*Aggiungere i **suffissi** qui di seguito in base al materiale e alla superficie richiesti.

ET-M-ED T di linea orientabile con dado girevole assemblato

Estremità conica EO 24° / Filettatura metrica maschio – Guarnizione ED (ISO 9974)

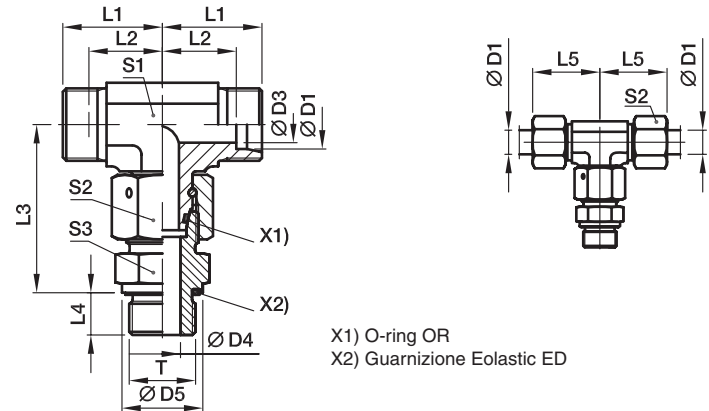

Serie	D1	T	D3	D4	D5	L1	L2	L3	L4	L5	S1	S2	S3	Peso g/1 pezzo	Codice di ordinazione*	PN (bar) ¹⁾	
																CF	71
L ³⁾	06	M 10x1,0	4	4	14	19	12,0	34,5	8	27	12	14	14	55	ET06LMEDOMD	500	315
	08	M 12x1,5	6	6	17	21	14,0	37,5	12	29	12	17	17	75	ET08LMEDOMD	500	315
	10	M 14x1,5	8	7	19	22	15,0	40,0	12	30	14	19	19	98	ET10LMEDOMD	500	315
	12	M 16x1,5	10	9	22	24	17,0	42,0	12	32	17	22	22	135	ET12LMEDOMD	400	315
	15	M 18x1,5	12	11	24	28	21,0	46,0	12	36	19	27	24	203	ET15LMEDOMD	400	315
	18	M 22x1,5	15	14	27	31	23,5	50,0	14	40	24	32	27	310	ET18LMEDOMD	400	315
	22	M 26x1,5	19	18	32	35	27,5	55,0	16	44	27	36	32	377	ET22LMEDOMD	250	160
	28	M 33x2,0	24	23	40	38	30,5	59,0	18	47	36	41	41	607	ET28LMEDOMD	250	160
	35	M 42x2,0	30	30	50	45	34,5	68,5	20	56	41	50	50	929	ET35LMEDOMD	250	160
	42	M 48x2,0	36	36	55	51	40,0	75,0	22	63	50	60	55	1478	ET42LMEDOMD	250	160
S ⁴⁾	06	M 12x1,5	4	4	17	23	16,0	40,0	12	31	12	17	17	92	ET06SMEDOMD	800	630
	08	M 14x1,5	5	5	19	24	17,0	42,5	12	32	14	19	19	126	ET08SMEDOMD	800	630
	10	M 16x1,5	6	7	22	25	17,5	45,0	12	34	17	22	22	167	ET10SMEDOMD	800	630
	12	M 18x1,5	8	8	24	29	21,5	48,0	12	38	17	24	24	207	ET12SMEDOMD	630	630
	14	M 20x1,5	9	10	26	30	22,0	54,0	14	40	19	27	27	287	ET14SMEDOMD	630	630
	16	M 22x1,5	12	12	27	33	24,5	55,0	14	43	24	30	27	352	ET16SMEDOMD	630	400
	20	M 27x2,0	16	16	32	37	26,5	65,0	16	48	27	36	32	498	ET20SMEDOMD	420	400
	25	M 33x2,0	20	20	40	42	30,0	73,0	18	54	36	46	41	916	ET25SMEDOMD	420	400
	30	M 42x2,0	25	25	50	49	35,5	78,5	20	62	41	50	50	1328	ET30SMEDOMD	420	400
	38	M 48x2,0	32	32	55	57	41,0	89,0	22	72	50	60	55	2031	ET38SMEDOMD	420	315

¹⁾ Pressione indicata = Articolo disponibile

³⁾ L = Serie leggera; ⁴⁾ S = Serie pesante

$$\frac{PN \text{ (bar)}}{10} = PN \text{ (MPa)}$$

Consegna senza dado né anello. Per informazioni sull'ordinazione di raccordi completi o sui materiali di tenuta alternativi vedere pag. I7.

Suffissi codice di ordinazione			
Materiale	Suffisso superficie e materiale	Esempio	Materiale di tenuta standard (non occorre suffisso aggiuntivo)
Acciaio, zincato, esente da CromoVI	CF	ET16SMEDOMDCF	NBR
Acciaio inossidabile	71	ET16SMEDOMD71	VIT

*Aggiungere i suffissi qui di seguito in base al materiale e alla superficie richiesti.

ET-R-ED T di linea orientabile con dado girevole assemblato

Estremità conica EO 24° / Filettatura maschio BSPP – Guarnizione ED (ISO 1179)

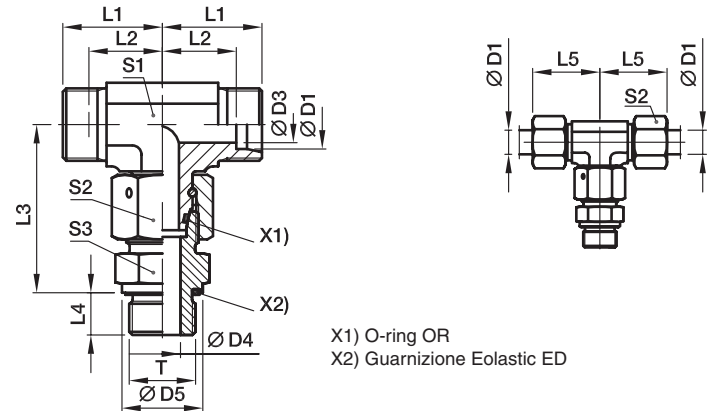

Serie	D1	T	D3	D4	D5	L1	L2	L3	L4	L5	S1	S2	S3	Peso g/1 pezzo	Codice di ordinazione*	PN (bar) ¹⁾	
																CF	71
L ³⁾	06	G 1/8 A	4	4	14	19	12,0	34,5	8	27	12	14	14	55	ET06LREDOMD	500	315
	08	G 1/4 A	6	6	19	21	14,0	37,5	12	29	12	17	19	80	ET08LREDOMD	500	315
	10	G 1/4 A	8	6	19	22	15,0	40,0	12	30	14	19	19	98	ET10LREDOMD	500	315
	12	G 3/8 A	10	9	22	24	17,0	42,0	12	32	17	22	22	136	ET12LREDOMD	400	315
	15	G 1/2 A	12	11	27	28	21,0	46,5	14	36	19	27	27	224	ET15LREDOMD	400	315
	18	G 1/2 A	15	14	27	31	23,5	50,0	14	40	24	32	27	306	ET18LREDOMD	400	315
	22	G 3/4 A	19	18	32	35	27,5	55,0	16	44	27	36	32	423	ET22LREDOMD	250	160
	28	G 1 A	24	23	40	38	30,5	59,0	18	47	36	41	41	608	ET28LREDOMD	250	160
	35	G 1 1/4 A	30	30	50	45	34,5	68,5	20	56	41	50	50	920	ET35LREDOMD	250	160
	42	G 1 1/2 A	36	36	55	51	40,0	75,0	22	63	50	60	55	1466	ET42LREDOMD	250	160
S ⁴⁾	06	G 1/4 A	4	4	19	23	16,0	40,0	12	31	12	17	19	98	ET06SREDOMD	800	630
	08	G 1/4 A	5	5	19	24	17,0	42,5	12	32	14	19	19	125	ET08SREDOMD	800	630
	10	G 3/8 A	6	7	22	25	17,5	45,0	12	34	17	22	22	169	ET10SREDOMD	800	630
	12	G 3/8 A	8	8	22	29	21,5	48,0	12	38	17	24	22	198	ET12SREDOMD	630	630
	14	G 1/2 A	9	10	27	30	22,0	54,0	14	40	19	27	27	287	ET14SREDOMD	630	630
	16	G 1/2 A	12	12	27	33	24,5	55,0	14	43	24	30	27	348	ET16SREDOMD	630	400
	20	G 3/4 A	16	16	32	37	26,5	65,0	16	48	27	36	32	498	ET20SREDOMD	420	400
	25	G 1 A	20	20	40	42	30,0	73,0	18	54	36	46	41	918	ET25SREDOMD	420	400
	30	G 1 1/4 A	25	25	50	49	35,5	78,5	20	62	41	50	50	1324	ET30SREDOMD	420	400
	38	G 1 1/2 A	32	32	55	57	41,0	89,0	22	72	50	60	55	2025	ET38SREDOMD	420	315

¹⁾ Pressione indicata = Articolo disponibile

³⁾ L = Serie leggera; ⁴⁾ S = Serie pesante

$$\frac{PN \text{ (bar)}}{10} = PN \text{ (MPa)}$$

Consegna senza dado né anello. Per informazioni sull'ordinazione di raccordi completi o sui materiali di tenuta alternativi vedere pag. I7.

Suffissi codice di ordinazione			
Materiale	Suffisso superficie e materiale	Esempio	Materiale di tenuta standard (non occorre suffisso aggiuntivo)
Acciaio, zincato, esente da CromoVI	CF	ET16SREDOMDCF	NBR
Acciaio inossidabile	71	ET16SREDOMD71	VIT

*Aggiungere i **suffissi** qui di seguito in base al materiale e alla superficie richiesti.

EL-M-ED T di derivazione orientabile con dado girevole assemblato

Estremità conica EO 24° / Filettatura maschio metrica – Guarnizione ED (ISO 9974)

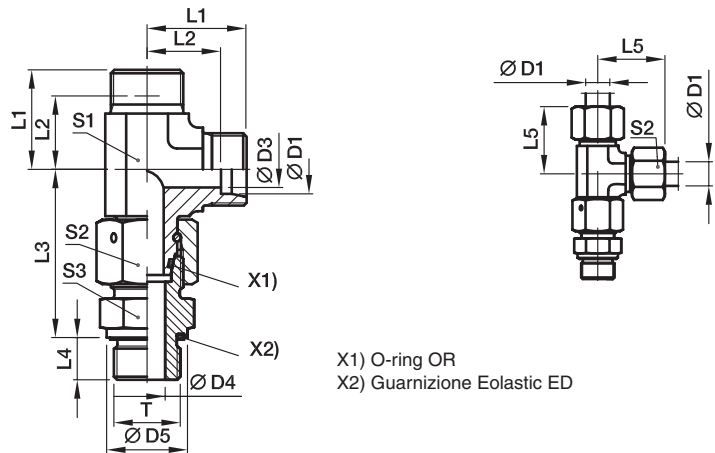

X1) O-ring OR
X2) Guarnizione Eolastic ED

Serie	D1	T	D3	D4	D5	L1	L2	L3	L4	L5	S1	S2	S3	Peso g/1 pezzo	Codice di ordinazione*	PN (bar) ¹⁾	
																CF	71
L ³⁾	06	M 10x1,0	4	4	14	19	12,0	34,5	8	27	12	14	14	55	EL06LMEDOMD	500	315
	08	M 12x1,5	6	6	17	21	14,0	37,5	12	29	12	17	17	75	EL08LMEDOMD	500	315
	10	M 14x1,5	8	7	19	22	15,0	40,0	12	30	14	19	19	97	EL10LMEDOMD	500	315
	12	M 16x1,5	10	9	22	24	17,0	42,0	12	32	17	22	22	135	EL12LMEDOMD	400	315
	15	M 18x1,5	12	11	24	28	21,0	46,0	12	36	19	27	24	201	EL15LMEDOMD	400	315
	18	M 22x1,5	15	14	27	31	23,5	50,0	14	40	24	32	27	308	EL18LMEDOMD	400	315
	22	M 26x1,5	19	18	32	35	27,5	55,0	16	44	27	36	32	404	EL22LMEDOMD	250	160
	28	M 33x2,0	24	23	40	38	30,5	59,0	18	47	36	41	41	605	EL28LMEDOMD	250	160
	35	M 42x2,0	30	30	50	45	34,5	68,5	20	56	41	50	50	947	EL35LMEDOMD	250	160
	42	M 48x2,0	36	36	55	51	40,0	75,0	22	63	50	60	55	1497	EL42LMEDOMD	250	160
S ⁴⁾	06	M 12x1,5	4	4	17	23	16,0	40,0	12	31	12	17	17	91	EL06SMEDOMD	800	630
	08	M 14x1,5	5	5	19	24	17,0	42,5	12	32	14	19	19	126	EL08SMEDOMD	800	630
	10	M 16x1,5	6	7	22	25	17,5	45,0	12	34	17	22	22	169	EL10SMEDOMD	800	630
	12	M 18x1,5	8	8	24	29	21,5	48,0	12	38	17	24	24	206	EL12SMEDOMD	630	630
	14	M 20x1,5	9	10	26	30	22,0	54,0	14	40	19	27	27	275	EL14SMEDOMD	630	630
	16	M 22x1,5	12	12	27	33	24,5	55,0	14	43	24	30	27	354	EL16SMEDOMD	630	400
	20	M 27x2,0	16	16	32	37	26,5	65,0	16	48	27	36	32	526	EL20SMEDOMD	420	400
	25	M 33x2,0	20	20	40	42	30,0	73,0	18	54	36	46	41	919	EL25SMEDOMD	420	400
	30	M 42x2,0	25	25	50	49	35,5	78,5	20	62	41	50	50	1328	EL30SMEDOMD	420	400
	38	M 48x2,0	32	32	55	57	41,0	89,0	22	72	50	60	55	2039	EL38SMEDOMD	420	315

¹⁾ Pressione indicata = Articolo disponibile

³⁾ L = Serie leggera; ⁴⁾ S = Serie pesante

$$\frac{PN \text{ (bar)}}{10} = PN \text{ (MPa)}$$

Consegna senza dado né anello. Per informazioni sull'ordinazione di raccordi completi o sui materiali di tenuta alternativi vedere pag. I7.

Suffissi codice di ordinazione			
Materiale	Suffisso superficie e materiale	Esempio	Materiale di tenuta standard (non occorre suffisso aggiuntivo)
Acciaio, zincato, esente da CromoVI	CF	EL16SMEDOMDCF	NBR
Acciaio inossidabile	71	EL16SMEDOMD71	VIT

*Aggiungere i **suffissi** qui di seguito in base al materiale e alla superficie richiesti.

EL-R-ED T di derivazione orientabile con dado girevole assemblato

Estremità conica EO 24° / Filettatura metrica BSPP – Guarnizione ED (ISO 1179)

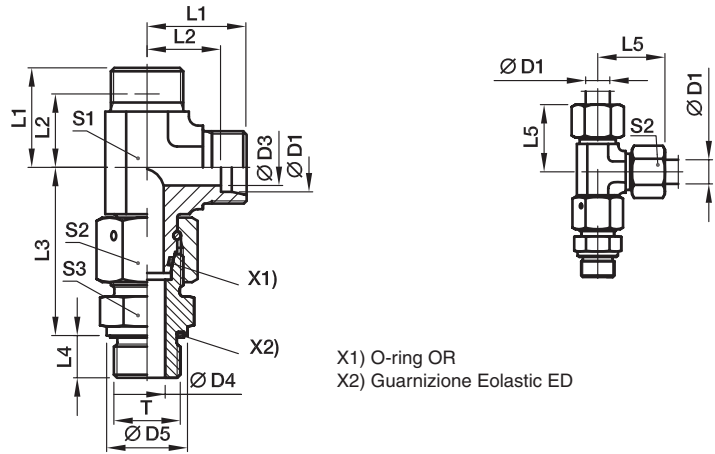

X1) O-ring OR
X2) Guarnizione Eolastic ED

Serie	D1	T	D3	D4	D5	L1	L2	L3	L4	L5	S1	S2	S3	Peso g/1 pezzo	Codice di ordinazione*	PN (bar) ¹⁾	
																CF	71
L3)	06	G 1/8 A	4	4	14	19	12,0	34,5	8	27	12	14	14	55	EL06LREDOMD	500	315
	08	G 1/4 A	6	6	19	21	14,0	37,5	12	29	12	17	19	80	EL08LREDOMD	500	315
	10	G 1/4 A	8	6	19	22	15,0	40,0	12	30	14	19	19	97	EL10LREDOMD	500	315
	12	G 3/8 A	10	9	22	24	17,0	42,0	12	32	17	22	22	137	EL12LREDOMD	400	315
	15	G 1/2 A	12	11	27	28	21,0	46,5	14	36	19	27	27	222	EL15LREDOMD	400	315
	18	G 1/2 A	15	14	27	31	23,5	50,0	14	40	24	32	27	304	EL18LREDOMD	400	315
	22	G 3/4 A	19	18	32	35	27,5	55,0	16	44	27	36	32	404	EL22LREDOMD	250	160
	28	G 1 A	24	23	40	38	30,5	59,0	18	47	36	41	41	606	EL28LREDOMD	250	160
	35	G 1 1/4 A	30	30	50	45	34,5	68,5	20	56	41	50	50	938	EL35LREDOMD	250	160
	42	G 1 1/2 A	36	36	55	51	40,0	75,0	22	63	50	60	55	1485	EL42LREDOMD	250	160
S4)	06	G 1/4 A	4	4	19	23	16,0	40,0	12	31	12	17	19	97	EL06SREDOMD	800	630
	08	G 1/4 A	5	5	19	24	17,0	42,5	12	32	14	19	19	125	EL08SREDOMD	800	630
	10	G 3/8 A	6	7	22	25	17,5	45,0	12	34	17	22	22	171	EL10SREDOMD	800	630
	12	G 3/8 A	8	8	22	29	21,5	48,0	12	38	17	24	22	198	EL12SREDOMD	630	630
	14	G 1/2 A	9	10	27	30	22,0	54,0	14	40	19	27	27	269	EL14SREDOMD	630	630
	16	G 1/2 A	12	12	27	33	24,5	55,0	14	43	24	30	27	350	EL16SREDOMD	630	400
	20	G 3/4 A	16	16	32	37	26,5	65,0	16	48	27	36	32	524	EL20SREDOMD	420	400
	25	G 1 A	20	20	40	42	30,0	73,0	18	54	36	46	41	921	EL25SREDOMD	420	400
	30	G 1 1/4 A	25	25	50	49	35,5	78,5	20	62	41	50	50	1324	EL30SREDOMD	420	400
	38	G 1 1/2 A	32	32	55	57	41,0	89,0	22	72	50	60	55	2033	EL38SREDOMD	420	315

¹⁾ Pressione indicata = Articolo disponibile

³⁾ L = Serie leggera; ⁴⁾ S = Serie pesante

$$\frac{PN \text{ (bar)}}{10} = PN \text{ (MPa)}$$

Consegna senza dado né anello. Per informazioni sull'ordinazione di raccordi completi o sui materiali di tenuta alternativi vedere pag. I7.

Suffissi codice di ordinazione			
Materiale	Suffisso superficie e materiale	Esempio	Materiale di tenuta standard (non occorre suffisso aggiuntivo)
Acciaio, zincato, esente da CromoVI	CF	EL16SREDOMDCF	NBR
Acciaio inossidabile	71	EL16SREDOMD71	VIT

*Aggiungere i **suffissi** qui di seguito in base al materiale e alla superficie richiesti.

EVW-M Gomito codolo orientabile assemblato

Estremità conica EO 24° / Filettatura maschio metrica – bordo di tenuta metallico (ISO 9974)

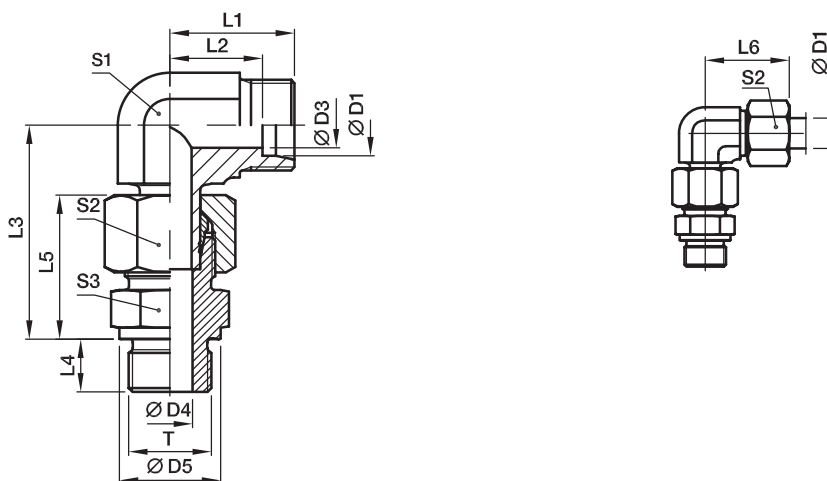

Premontato, completo di terminale maschio diritto (con superficie tagliente DIN 3852, tipo B).
Montaggio finale (in apposito corpo) almeno 1/4 di giro oltre il punto di resistenza chiaramente percepibile.

Serie	D1	T	D3	D4	D5	L1	L2	L3	L4	L5	L6	S1	S2	S3	Peso g/1 pezzo	Codice di ordinazione*	PN (bar) ¹⁾	
																	CF	71
L ³⁾	06	M 10x1,0	4	4	14	19	12,0	34,5	8	23	27	12	14	14	41	EVW06LMOMD	315	315
	08	M 12x1,5	6	6	17	21	14,0	37,5	12	25	29	12	17	17	63	EVW08LMOMD	315	315
	10	M 14x1,5	8	7	19	22	15,0	40,0	12	26	30	14	19	19	83	EVW10LMOMD	315	315
	12	M 16x1,5	10	9	21	24	17,0	42,0	12	27	32	17	22	22	107	EVW12LMOMD	315	315
	15	M 18x1,5	12	11	23	28	21,0	46,0	12	29	36	19	27	24	170	EVW15LMOMD	250	250
	18	M 22x1,5	15	14	27	31	23,5	50,0	14	31	40	24	32	27	265	EVW18LMOMD	250	250
	22	M 26x1,5	19	18	31	35	27,5	55,0	16	33	44	27	36	32	355	EVW22LMOMD	160	160
	28	M 33x2,0	24	23	39	38	30,5	59,5	18	34	47	36	41	41	514	EVW28LMOMD	160	160
	35	M 42x2,0	30	30	49	45	34,5	68,5	20	39	56	41	50	50	791	EVW35LMOMD	160	160
	42	M 48x2,0	36	36	55	51	40,0	79,0	22	42	63	50	60	55	1153	EVW42LMOMD	160	160
S ⁴⁾	06	M 12x1,5	4	4	17	23	16,0	40,0	12	28	31	12	17	17	73	EVW06SMOMD	400	400
	08	M 14x1,5	5	5	19	24	17,0	42,5	12	30	32	14	19	19	100	EVW08SMOMD	400	400
	10	M 16x1,5	7	7	21	25	17,5	46,0	12	31	34	17	22	22	133	EVW10SMOMD	400	400
	12	M 18x1,5	8	8	23	29	21,5	48,0	12	33	38	17	24	24	174	EVW12SMOMD	400	400
	14	M 20x1,5	10	10	25	30	22,0	54,0	14	37	40	19	27	27	229	EVW14SMOMD	400	400
	16	M 22x1,5	12	12	27	33	24,5	56,0	14	37	43	24	30	27	309	EVW16SMOMD	400	400
	20	M 27x2,0	16	16	32	37	26,5	65,0	16	42	48	27	36	32	429	EVW20SMOMD	400	400
	25	M 33x2,0	20	20	39	42	30,0	73,0	18	47	54	36	46	41	826	EVW25SMOMD	250	250
	30	M 42x2,0	25	25	49	49	35,5	78,5	20	50	62	41	50	50	1132	EVW30SMOMD	160	160
	38	M 48x2,0	32	32	55	57	41,0	92,5	22	57	72	50	60	55	1874	EVW38SMOMD	160	160

¹⁾ Pressione indicata = Articolo disponibile

³⁾ L = Serie leggera; ⁴⁾ S = Serie pesante

$$\frac{PN \text{ (bar)}}{10} = PN \text{ (MPa)}$$

Consegna senza dado né anello. Per informazioni sull'ordinazione di raccordi completi vedere pag. 17.

*Aggiungere i suffissi qui di seguito in base al materiale e alla superficie richiesti.

Suffissi codice di ordinazione		
Materiale	Suffisso superficie e materiale	Esempio
Acciaio, zincato, esente da CromoVI	CF	EVW16SMOMDCF
Acciaio inossidabile	71	EVW16SMOMD71

EVW-R Gomito codolo orientabile assemblato

Estremità conica EO 24° / Filettatura maschio BSPP – bordo di tenuta metallico (ISO 9974)

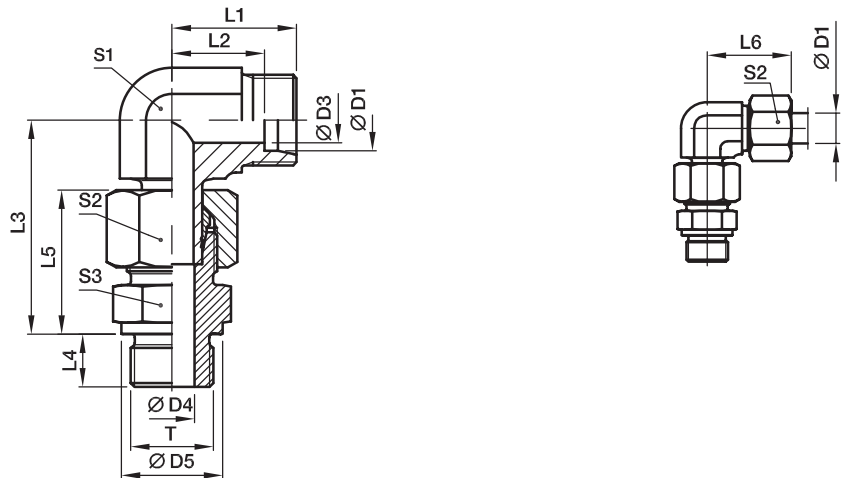

Premontato, completo di terminale maschio diritto (con superficie tagliente DIN 3852, tipo B).
Montaggio finale (in apposito corpo) almeno 1/4 di giro oltre il punto di resistenza chiaramente percepibile.

Serie	D1 	T	D3	D4	D5	L1	L2	L3	L4	L5	L6	S1	S2	S3	Peso g/1 pezzo	Codice di ordinazione*	PN (bar) ¹⁾	
																	CF	71
L ³⁾	06	G 1/8 A	4	4	14	19	12,0	34,5	8	23	27	12	14	14	47	EVW06LROMD	315	315
	08	G 1/4 A	6	6	18	21	14,0	37,5	12	25	29	12	17	19	68	EVW08LROMD	315	315
	10	G 1/4 A	8	6	18	22	15,0	40,0	12	26	30	14	19	19	84	EVW10LROMD	315	315
	12	G 3/8 A	10	9	22	24	17,0	42,0	12	27	32	17	22	22	118	EVW12LROMD	315	315
	15	G 1/2 A	12	11	26	28	21,0	46,5	14	29	36	19	27	27	191	EVW15LROMD	250	250
	18	G 1/2 A	15	14	26	31	23,5	50,0	14	31	40	24	32	27	260	EVW18LROMD	250	250
	22	G 3/4 A	19	18	32	35	27,5	55,0	16	33	44	27	36	32	355	EVW22LROMD	160	160
	28	G 1 A	24	23	39	38	30,5	59,5	18	34	47	36	41	41	542	EVW28LROMD	160	160
	35	G 1 1/4 A	30	30	49	45	34,5	68,5	20	39	56	41	50	50	832	EVW35LROMD	160	160
	42	G 1 1/2 A	36	36	55	51	40,0	79,0	22	42	63	50	60	55	1303	EVW42LROMD	160	160
S ⁴⁾	06	G 1/4 A	4	4	18	23	16,0	40,0	12	28	31	12	17	19	79	EVW06SROMD	400	400
	08	G 1/4 A	5	5	18	24	17,0	42,5	12	30	32	14	19	19	98	EVW08SROMD	400	400
	10	G 3/8 A	7	7	22	25	17,5	46,0	12	31	34	17	22	22	148	EVW10SROMD	400	400
	12	G 3/8 A	8	8	22	29	21,5	48,0	12	33	38	17	24	22	169	EVW12SROMD	400	400
	14	G 1/2 A	10	10	26	30	22,0	54,0	14	37	40	19	27	27	230	EVW14SROMD	400	400
	16	G 1/2 A	12	12	26	33	24,5	56,0	14	37	43	24	30	27	304	EVW16SROMD	400	400
	20	G 3/4 A	16	16	32	37	26,5	65,0	16	42	48	27	36	32	428	EVW20SROMD	400	400
	25	G 1 A	20	20	39	42	30,0	73,0	18	47	54	36	46	41	825	EVW25SROMD	250	250
	30	G 1 1/4 A	25	25	49	49	35,5	78,5	20	50	62	41	50	50	1134	EVW30SROMD	160	160
	38	G 1 1/2 A	32	32	55	57	41,0	92,5	22	57	72	50	60	55	1713	EVW38SROMD	160	160

¹⁾ Pressione indicata = Articolo disponibile

³⁾ L = Serie leggera; ⁴⁾ S = Serie pesante

$$\frac{PN \text{ (bar)}}{10} = PN \text{ (MPa)}$$

Consegna senza dado né anello. Per informazioni sull'ordinazione di raccordi completi vedere pag. 17.

*Aggiungere i **suffissi** qui di seguito in base al materiale e alla superficie richiesti.

Suffissi codice di ordinazione		
Materiale	Suffisso superficie e materiale	Esempio
Acciaio, zincato, esente da CromoVI	CF	EVW16SROMDCF
Acciaio inossidabile	71	EVW16SROMD71

EVT-M T di linea codolo orientabile assemblato

Estremità conica EO 24° / Filettatura maschio metrica – bordo di tenuta metallico (ISO 9974)

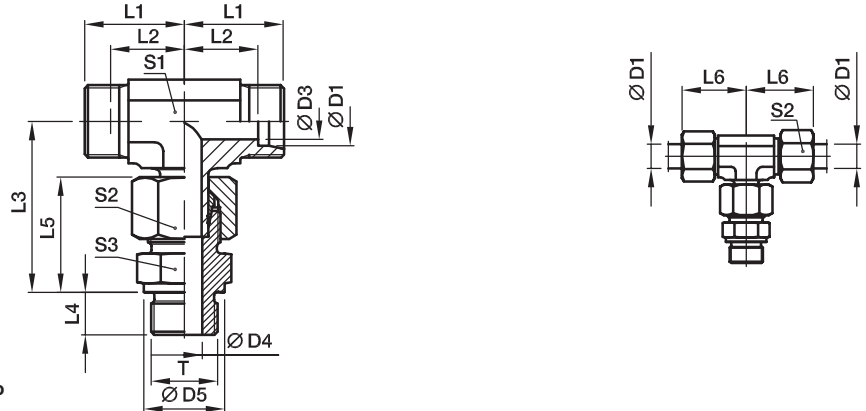

Premontato, completo di terminale maschio diritto (con superficie tagliente).
Montaggio finale (in apposito corpo) almeno 1/4 di giro oltre il punto di resistenza chiaramente percepibile.

Serie	D1	T	D3	D4	D5	L1	L2	L3	L4	L5	L6	S1	S2	S3	Peso g/1 pezzo	Codice di ordinazione*	PN (bar) ¹⁾	
																	CF	71
L ³⁾	06	M 10x1,0	4	4	14	19	12,0	34,5	8	23	27	12	14	14	48	EVT06LMOMD	315	315
	08	M 12x1,5	6	6	17	21	14,0	37,5	12	25	29	12	17	17	68	EVT08LMOMD	315	315
	10	M 14x1,5	8	7	19	22	15,0	40,0	12	26	30	14	19	19	88	EVT10LMOMD	315	315
	12	M 16x1,5	10	9	21	24	17,0	43,0	12	27	32	17	22	22	116	EVT12LMOMD	315	315
	15	M 18x1,5	12	11	23	28	21,0	46,0	12	29	36	19	27	24	185	EVT15LMOMD	250	250
	18	M 22x1,5	15	14	27	31	23,5	50,0	14	31	40	24	32	27	272	EVT18LMOMD	250	250
	22	M 26x1,5	19	18	31	35	27,5	55,5	16	33	44	27	36	32	367	EVT22LMOMD	160	160
	28	M 33x2,0	24	23	39	38	30,5	61,0	18	34	47	36	41	41	565	EVT28LMOMD	160	160
	35	M 42x2,0	30	30	49	45	34,5	72,0	20	39	56	41	50	50	905	EVT35LMOMD	160	160
	42	M 48x2,0	36	36	55	51	40,0	79,0	22	42	63	50	60	55	1282	EVT42LMOMD	160	160
S ⁴⁾	06	M 12x1,5	4	4	17	23	16,0	40,0	12	28	31	12	17	17	85	EVT06SMOMD	400	400
	08	M 14x1,5	5	5	19	24	17,0	44,0	12	30	32	14	19	19	118	EVT08SMOMD	400	400
	10	M 16x1,5	7	7	21	25	17,5	47,0	12	31	34	17	22	22	149	EVT10SMOMD	400	400
	12	M 18x1,5	8	8	23	29	21,5	50,0	12	33	38	17	24	24	200	EVT12SMOMD	400	400
	14	M 20x1,5	10	10	25	30	22,0	54,0	14	37	40	19	27	27	264	EVT14SMOMD	400	400
	16	M 22x1,5	12	12	27	33	24,5	55,0	14	37	43	24	30	27	327	EVT16SMOMD	400	400
	20	M 27x2,0	16	16	32	37	26,5	65,0	16	42	48	27	36	32	482	EVT20SMOMD	400	400
	25	M 33x2,0	20	20	39	42	30,0	73,5	18	47	54	36	46	41	906	EVT25SMOMD	250	250
	30	M 42x2,0	25	25	49	49	35,5	80,0	20	50	62	41	50	50	1274	EVT30SMOMD	160	160
	38	M 48x2,0	32	32	55	57	41,0	92,5	22	57	72	50	60	55	1928	EVT38SMOMD	160	160

¹⁾ Pressione indicata = Articolo disponibile

³⁾ L = Serie leggera; ⁴⁾ S = Serie pesante

$$\frac{PN \text{ (bar)}}{10} = PN \text{ (MPa)}$$

Consegna senza dado né anello. Per informazioni sull'ordinazione di raccordi completi vedere pag. 17.

*Aggiungere i suffissi qui di seguito in base al materiale e alla superficie richiesti.

Suffissi codice di ordinazione		
Materiale	Suffisso superficie e materiale	Esempio
Acciaio, zincato, esente da CromoVI	CF	EVT16SMOMDCF
Acciaio inossidabile	71	EVT16SMOMD71

EVT-R T di linea codolo orientabile assemblato

Estremità conica EO 24° / Filettatura maschio BSPP – bordo di tenuta metallico (ISO 1179)

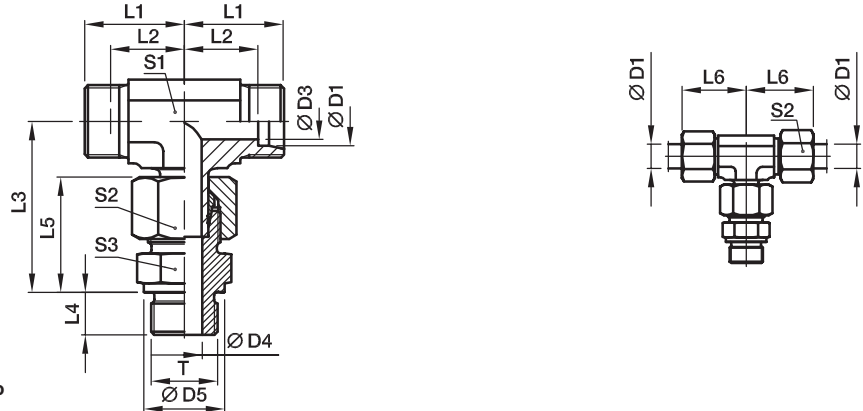

Premontato, completo di terminale maschio diritto (con superficie tagliente).
Montaggio finale (in apposito corpo) almeno 1/4 di giro oltre il punto di resistenza chiaramente percepibile.

Serie	D1	T	D3	D4	D5	L1	L2	L3	L4	L5	L6	S1	S2	S3	Peso g/1 pezzo	Codice di ordinazione*	PN (bar) ¹⁾	
																	CF	71
L ³⁾	06	G 1/8 A	4	4	14	19	12,0	34,5	8	23	27	12	14	14	48	EVT06LROMD	315	315
	08	G 1/4 A	6	6	18	21	14,0	37,5	12	25	29	12	17	19	73	EVT08LROMD	315	315
	10	G 1/4 A	8	6	18	22	15,0	40,0	12	26	30	14	19	19	85	EVT10LROMD	315	315
	12	G 3/8 A	10	9	22	24	17,0	43,0	12	27	32	17	22	22	118	EVT12LROMD	315	315
	15	G 1/2 A	12	11	26	28	21,0	46,5	14	29	36	19	27	27	206	EVT15LROMD	250	250
	18	G 1/2 A	15	14	26	31	23,5	50,0	14	31	40	24	32	27	267	EVT18LROMD	250	250
	22	G 3/4 A	19	18	32	35	27,5	55,5	16	33	44	27	36	32	367	EVT22LROMD	160	160
	28	G 1 A	24	23	39	38	30,5	61,0	18	34	47	36	41	41	565	EVT28LROMD	160	160
	35	G 1 1/4 A	30	30	49	45	34,5	72,0	20	39	56	41	50	50	901	EVT35LROMD	160	160
	42	G 1 1/2 A	36	36	55	51	40,0	79,0	22	42	63	50	60	55	1277	EVT42LROMD	160	160
S ⁴⁾	06	G 1/4 A	4	4	18	23	16,0	40,0	12	28	31	12	17	19	90	EVT06SROMD	400	400
	08	G 1/4 A	5	5	18	24	17,0	44,0	12	30	32	14	19	19	116	EVT08SROMD	400	400
	10	G 3/8 A	7	7	22	25	17,5	47,0	12	31	34	17	22	22	151	EVT10SROMD	400	400
	12	G 3/8 A	8	8	22	29	21,5	50,0	12	33	38	17	24	22	190	EVT12SROMD	400	400
	14	G 1/2 A	10	10	26	30	22,0	54,0	14	37	40	19	27	27	265	EVT14SROMD	400	400
	16	G 1/2 A	12	12	26	33	24,5	55,0	14	37	43	24	30	27	322	EVT16SROMD	400	400
	20	G 3/4 A	16	16	32	37	26,5	65,0	16	42	48	27	36	32	500	EVT20SROMD	400	400
	25	G 1 A	20	20	39	42	30,0	73,5	18	47	54	36	46	41	905	EVT25SROMD	250	250
	30	G 1 1/4 A	25	25	49	49	35,5	80,0	20	50	62	41	50	50	1275	EVT30SROMD	160	160
	38	G 1 1/2 A	32	32	55	57	41,0	92,5	22	57	72	50	60	55	1920	EVT38SROMD	160	160

1) Pressione indicata = Articolo disponibile

3) L = Serie leggera; 4) S = Serie pesante

$$\frac{PN \text{ (bar)}}{10} = PN \text{ (MPa)}$$

Consegna senza dado né anello. Per informazioni sull'ordinazione di raccordi completi vedere pag. 17.

*Aggiungere i **suffissi** qui di seguito in base al materiale e alla superficie richiesti.

Suffissi codice di ordinazione		
Materiale	Suffisso superficie e materiale	Esempio
Acciaio, zincato, esente da CromoVI	CF	EVT16SROMDCF
Acciaio inossidabile	71	EVT16SROMD71

EVL-M T di derivazione codolo orientabile assemblato

Estremità conica EO 24° / Filettatura maschio metrica – bordo di tenuta metallico (ISO 9974)

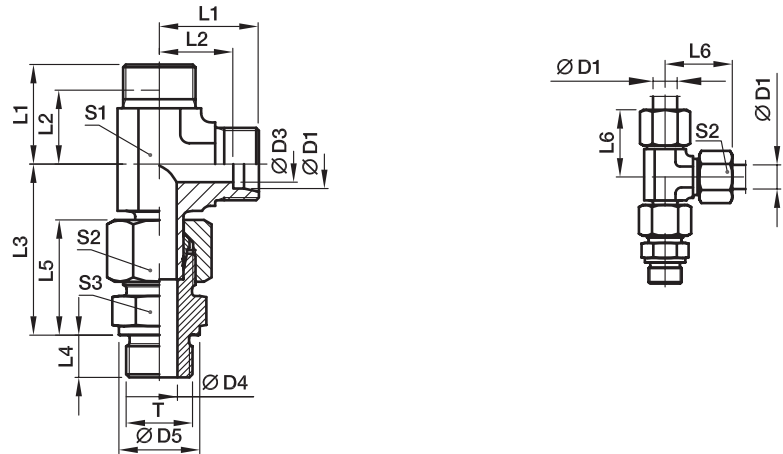

Premontato, completo di terminale maschio diritto (con superficie tagliente).
Montaggio finale (in apposito corpo) almeno 1/4 di giro oltre il punto di resistenza chiaramente percepibile.

Serie	D1	T	D3	D4	D5	L1	L2	L3	L4	L5	L6	S1	S2	S3	Peso g/1 pezzo	Codice di ordinazione*	PN (bar) ¹⁾	
																	CF	71
L ³⁾	06	M 10x1,0	4	4	14	19	12,0	34,5	8	23	27	12	14	14	48	EVL06LMOMD	315	315
	08	M 12x1,5	6	6	17	21	14,0	37,5	12	25	29	12	17	17	73	EVL08LMOMD	315	315
	10	M 14x1,5	8	7	19	22	15,0	40,0	12	26	30	14	19	19	89	EVL10LMOMD	315	315
	12	M 16x1,5	10	9	21	24	17,0	43,0	12	27	32	17	22	22	118	EVL12LMOMD	315	315
	15	M 18x1,5	12	11	23	28	21,0	46,0	12	29	36	19	27	24	186	EVL15LMOMD	250	250
	18	M 22x1,5	15	14	27	31	23,5	50,0	14	31	40	24	32	27	269	EVL18LMOMD	250	250
	22	M 26x1,5	19	18	31	35	27,5	55,5	16	33	44	27	36	32	364	EVL22LMOMD	160	160
	28	M 33x2,0	24	23	39	38	30,5	61,0	18	34	47	36	41	41	556	EVL28LMOMD	160	160
	35	M 42x2,0	30	30	49	45	34,5	72,0	20	39	56	41	50	50	900	EVL35LMOMD	160	160
	42	M 48x2,0	36	36	55	51	40,0	79,0	22	42	63	50	60	55	1323	EVL42LMOMD	160	160
S ⁴⁾	06	M 12x1,5	4	4	17	23	16,0	40,0	12	28	31	12	17	17	85	EVL06SMOMD	400	400
	08	M 14x1,5	5	5	19	24	17,0	44,0	12	30	32	14	19	19	119	EVL08SMOMD	400	400
	10	M 16x1,5	7	7	21	25	17,5	47,0	12	31	34	17	22	22	151	EVL10SMOMD	400	400
	12	M 18x1,5	8	8	23	29	21,5	50,0	12	33	38	17	24	24	202	EVL12SMOMD	400	400
	14	M 20x1,5	10	10	25	30	22,0	54,0	14	37	40	19	27	27	264	EVL14SMOMD	400	400
	16	M 22x1,5	12	12	27	33	24,5	56,0	14	37	43	24	30	27	326	EVL16SMOMD	400	400
	20	M 27x2,0	16	16	32	37	26,5	65,0	16	42	48	27	36	32	481	EVL20SMOMD	400	400
	25	M 33x2,0	20	20	39	42	30,0	73,5	18	47	54	36	46	41	904	EVL25SMOMD	250	250
	30	M 42x2,0	25	25	49	49	35,5	80,0	20	50	62	41	50	50	1263	EVL30SMOMD	160	160
	38	M 48x2,0	32	32	55	57	41,0	92,5	22	57	72	50	60	55	1936	EVL38SMOMD	160	160

¹⁾ Pressione indicata = Articolo disponibile

³⁾ L = Serie leggera; ⁴⁾ S = Serie pesante

$$\frac{PN \text{ (bar)}}{10} = PN \text{ (MPa)}$$

Consegna senza dado né anello. Per informazioni sull'ordinazione di raccordi completi vedere pag. 17.

*Aggiungere i **suffissi** qui di seguito in base al materiale e alla superficie richiesti.

Suffissi codice di ordinazione		
Materiale	Suffisso superficie e materiale	Esempio
Acciaio, zincato, esente da CromoVI	CF	EVL16SMOMDCF
Acciaio inossidabile	71	EVL16SMOMD71

EVL-R T di derivazione codolo orientabile assemblato

Estremità conica EO 24° / Filettatura maschio BSPP – bordo di tenuta metallico (ISO 1179)

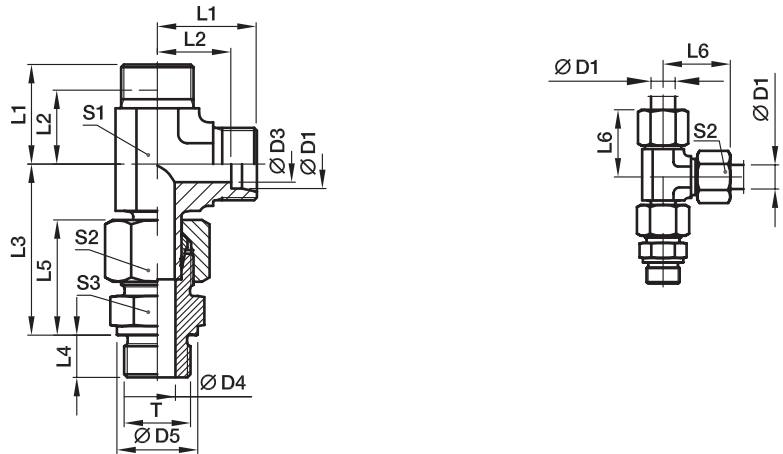

Premontato, completo di terminale maschio diritto (con superficie tagliente).
Montaggio finale (in apposito corpo) almeno 1/4 di giro oltre il punto di resistenza chiaramente percepibile.

Serie	D1	T	D3	D4	D5	L1	L2	L3	L4	L5	L6	S1	S2	S3	Peso g/1 pezzo	Codice di ordinazione*	PN (bar) ¹⁾	
																	CF	71
L3)	06	G 1/8 A	4	4	14	19	12,0	34,5	8	23	27	12	14	14	48	EVL06LROMD	315	315
	08	G 1/4 A	6	6	18	21	14,0	37,5	12	25	29	12	17	19	73	EVL08LROMD	315	315
	10	G 1/4 A	8	6	18	22	15,0	40,0	12	26	30	14	19	19	87	EVL10LROMD	315	315
	12	G 3/8 A	10	9	22	24	17,0	43,0	12	27	32	17	22	22	120	EVL12LROMD	315	315
	15	G 1/2 A	12	11	26	28	21,0	46,5	14	29	36	19	27	27	207	EVL15LROMD	250	250
	18	G 1/2 A	15	14	26	31	23,5	50,0	14	31	40	24	32	27	264	EVL18LROMD	250	250
	22	G 3/4 A	19	18	32	35	27,5	55,5	16	33	44	27	36	32	365	EVL22LROMD	160	160
	28	G 1 A	24	23	39	38	30,5	61,0	18	34	47	36	41	41	556	EVL28LROMD	160	160
	35	G 1 1/4 A	30	30	49	45	34,5	72,0	20	39	56	41	50	50	895	EVL35LROMD	160	160
	42	G 1 1/2 A	36	36	55	51	40,0	79,0	22	42	63	50	60	55	1318	EVL42LROMD	160	160
S4)	06	G 1/4 A	4	4	18	23	16,0	40,0	12	28	31	12	17	19	90	EVL06SROMD	400	400
	08	G 1/4 A	5	5	18	24	17,0	44,0	12	30	32	14	19	19	117	EVL08SROMD	400	400
	10	G 3/8 A	7	7	22	25	17,5	47,0	12	31	34	17	22	22	153	EVL10SROMD	400	400
	12	G 3/8 A	8	8	22	29	21,5	50,0	12	33	38	17	24	22	192	EVL12SROMD	400	400
	14	G 1/2 A	10	10	26	30	22,0	54,0	14	37	40	19	27	27	266	EVL14SROMD	400	400
	16	G 1/2 A	12	12	26	33	24,5	56,0	14	37	43	24	30	27	321	EVL16SROMD	400	400
	20	G 3/4 A	16	16	32	37	26,5	65,0	16	42	48	27	36	32	480	EVL20SROMD	400	400
	25	G 1 A	20	20	39	42	30,0	73,5	18	47	54	36	46	41	903	EVL25SROMD	250	250
	30	G 1 1/4 A	25	25	49	49	35,5	80,0	20	50	62	41	50	50	1265	EVL30SROMD	160	160
	38	G 1 1/2 A	32	32	55	57	41,0	92,5	22	57	72	50	60	55	1928	EVL38SROMD	160	160

¹⁾ Pressione indicata = Articolo disponibile

³⁾ L = Serie leggera; ⁴⁾ S = Serie pesante

$$\frac{PN \text{ (bar)}}{10} = PN \text{ (MPa)}$$

Consegna senza dado né anello. Per informazioni sull'ordinazione di raccordi completi vedere pag. 17.

*Aggiungere i suffissi qui di seguito in base al materiale e alla superficie richiesti.

Suffissi codice di ordinazione		
Materiale	Suffisso superficie e materiale	Esempio
Acciaio, zincato, esente da CromoVI	CF	EVL16SROMDCF
Acciaio inossidabile	71	EVL16SROMD71

WEE-R Gomito orientabile con dado di bloccaggio

Estremità conica EO 24° / Filettatura BSPP orientabile – O-ring + anello di ritenzione (ISO 1179) per connessioni con lamatura ampia o ridotta; le differenze in D5 in acciaio inossidabile riguardano solo le connessioni con lamatura ampia (es. WEE16SRBOMD71)

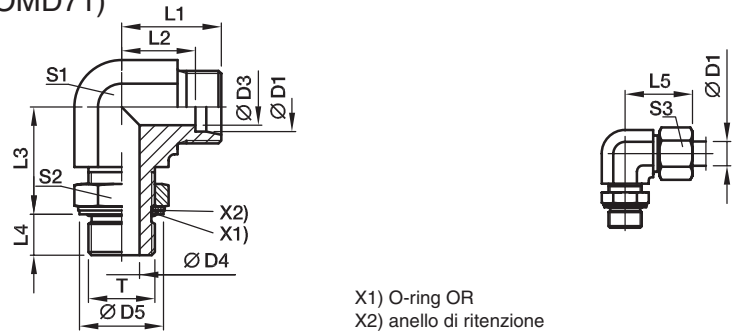

X1) O-ring OR
X2) anello di ritenzione

Serie	D1	T	D3	D4	D5 ⁵⁾	D5 ⁶⁾	L1	L2	L3	L4	L5	S1	S2	S3	Peso g/1 pezzo	Codice di ordinazione*	PN (bar) ¹⁾	
																	CF	71
LL ²⁾	04	G 1/8 A	3,0	4,5	15		15	11,3	20	7,1	21	11	14	10	27	WEE04LLROMD WEE06LLROMD	250	
	06	G 1/8 A	4,5	4,5	15		15	11,3	20	7,1	21	11	14	12	27		250	
L ³⁾	06	G 1/8 A	4,0	4,5	15	15,0	21	14,0	19	7,0	29	14	14	14	40	WEE06LROMD	315	315
	08	G 1/4 A	6,0	7,5	20	19,5	23	16,0	23	9,0	31	14	19	17	59	WEE08LROMD	315	315
	10	G 1/4 A	8,0	7,5	20	19,5	24	17,0	25	9,0	32	19	19	19	82	WEE10LROMD	315	315
	12	G 3/8 A	10,0	10,0	23	23,5	26	19,0	28	9,0	34	19	22	22	96	WEE12LROMD	250	250
	15	G 1/2 A	12,0	12,5	28	28,5	28	21,0	30	13,0	36	22	27	27	149	WEE15LROMD	250	250
	18	G 1/2 A	15,0	12,5	28	28,5	31	24,0	36	13,0	40	27	27	32	221	WEE18LROMD	250	250
	22	G 3/4 A	19,0	15,5	33	34,5	35	28,0	36	13,0	44	30	36	36	310	WEE22LROMD	160	160
	28	G 1 A	24,0	21,5	41	43,5	38	31,0	44	15,0	47	36	41	41	455	WEE28LROMD	160	160
	35	G 1 1/4 A	30,0	27,5	51	52,5	48	38,0	50	15,0	59	50	50	50	1043	WEE35LROMD	160	160
	42	G 1 1/2 A	36,0	33,0	56	60,0	49	38,0	52	15,0	61	50	55	60	994	WEE42LROMD	160	160
S ⁴⁾	06	G 1/4 A	4,0	7,5	20	19,5	22	15,0	23	9,0	30	14	19	17	56	WEE06SRROMD	315	315
	08	G 1/4 A	5,0	7,5	20	19,5	24	17,0	27	9,0	32	19	19	19	88	WEE08SRROMD	315	315
	10	G 3/8 A	7,0	10,0	23	23,5	25	18,0	29	9,0	34	19	22	22	98	WEE10SRROMD	250	250
	12	G 3/8 A	8,0	10,0	23	23,5	29	22,0	29	9,0	38	22	22	24	128	WEE12SRROMD	250	250
	16	G 1/2 A	12,0	12,5	28	28,5	33	25,0	36	13,0	43	27	27	30	234	WEE16SRROMD	250	250
	20	G 3/4 A	16,0	15,5	33	34,5	38	28,0	39	12,0	49	30	36	36	344	WEE20SRROMD	250	250
	25	G 1 A	20,0	21,5	41	43,5	42	30,0	44	14,0	54	36	41	46	533	WEE25SRROMD	250	250
	30	G 1 1/4 A	25,0	27,5	51	52,5	49	36,0	49	15,0	62	50	50	50	1085	WEE30SRROMD	160	160
	38	G 1 1/2 A	32,0	33,0	56	60,0	50	34,0	55	15,0	65	50	55	60	1116	WEE38SRROMD	160	160

¹⁾ Pressione indicata = Articolo disponibile

²⁾ LL = Serie ultraleggera; ³⁾ L = Serie leggera; ⁴⁾ S = Serie pesante

$$\frac{PN \text{ (bar)}}{10} = PN \text{ (MPa)}$$

Consegna senza dado né anello. Per informazioni sull'ordinazione di raccordi completi o sui materiali di tenuta alternativi vedere pag. 17.

⁵⁾ Acciaio; ⁶⁾ Acciaio inossidabile

Suffissi codice di ordinazione			
Materiale	Suffisso superficie e materiale	Esempio	Materiale di tenuta standard (non occorre suffisso aggiuntivo)
Acciaio, zincato, esente da CromoVI	CF	WEE16SRROMDCF	NBR
Acciaio inossidabile	71	WEE16SRBOMD71	VIT

*Aggiungere i suffissi qui di seguito in base al materiale e alla superficie richiesti.

Gomito orientabile con dado di bloccaggio, Tee o 45°

Su richiesta del cliente

WEE gomito orientabile con dado di bloccaggio EO24°/filettatura orientabile

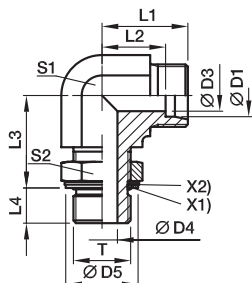

T	Cod. di ordinazione	Superficie
filettatura metrica – O-ring + anello di ritenzione	WEE...MOMD	CF
filettatura metrica – O-ring (ISO 6149)	WEE...MOROMD	CF
filettatura UN/UNF – O-ring (ISO 11926)	WEE...UNFOMD	CF

TEE gomito orientabile con dado di bloccaggio EO24°/filettatura orientabile

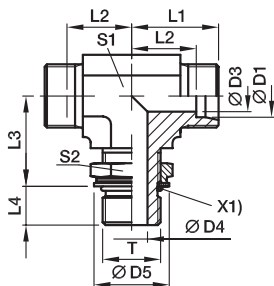

T	Cod. di ordinazione	Superficie
filettatura metrica – O-ring + anello di ritenzione	TEE...MOMD	CF
filettatura metrica – O-ring (ISO 6149)	TEE...MOROMD	CF
filettatura UN/UNF – O-ring (ISO 11926)	TEE...UNFOMD	CF
filett. BSPP – O-ring + anello di ritenzione (ISO 1179)	TEE...ROMD	CF

LEE gomito orientabile con dado di bloccaggio EO24°/filettatura orientabile

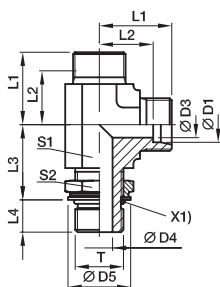

T	Cod. di ordinazione	Superficie
filettatura metrica – O-ring + anello di ritenzione	LEE...MOMD	CF
filettatura metrica – O-ring (ISO 6149)	LEE...MOROMD	CF
filettatura UN/UNF – O-ring (ISO 11926)	LEE...UNFOMD	CF
filett. BSPP – O-ring + anello di ritenzione (ISO 1179)	LEE...ROMD	CF

VEE gomito orientabile con dado di bloccaggio EO24°/filettatura orientabile

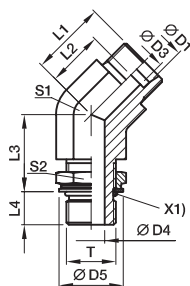

T	Cod. di ordinazione	Superficie
filettatura metrica – O-ring + anello di ritenzione	VEE...MOMD	CF
filettatura metrica – O-ring (ISO 6149)	VEE...MOROMD	CF
filettatura UN/UNF – O-ring (ISO 11926)	VEE...UNFOMD	CF
filett. BSPP – O-ring + anello di ritenzione (ISO 1179)	VEE...ROMD	CF

WH-M-KDS Gomito banjo per alte pressioni

Estremità conica EO 24° / Filettatura maschio metrica con anello di tenuta in gomma

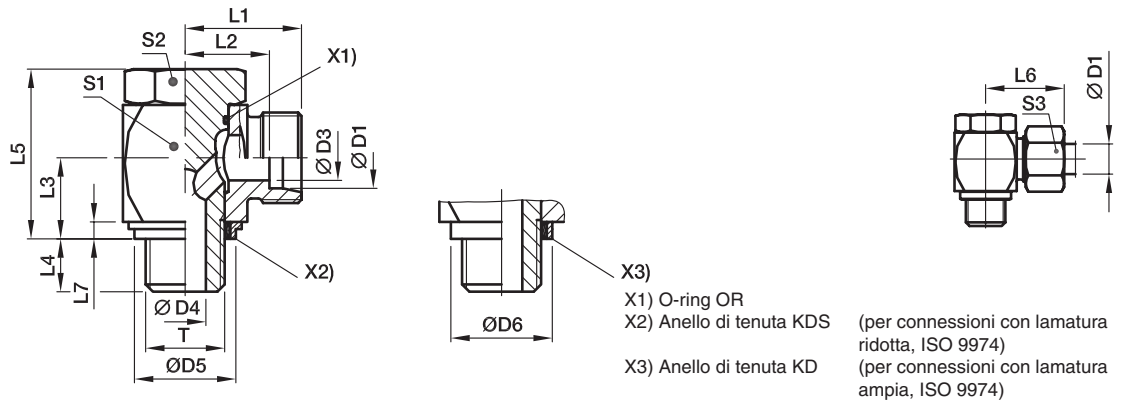

Serie	D1	T	D3	D4	D5 KDS	D6 KD	L1	L2	L3	L4	L5	L6	L7	S1	S2	S3	Peso g/1 pezzo	Codice di ordinazione*	PN (bar) ¹⁾	
																			CF	71
L ³⁾	06	M 10×1,0	4	4,5	14,9	17,0	19,0	12,0	10,5	8	24,0	27	2,5	17	17	14	54	WH06LMKDSOMD	315	315
	08	M 12×1,5	6	6,0	17,0	22,0	21,5	14,5	14,0	12	30,0	29	3,0	22	19	17	97	WH08LMKDSOMD	315	315
	10	M 14×1,5	8	6,0	18,9	22,5	22,5	15,5	14,0	12	30,0	30	3,0	22	19	19	104	WH10LMKDSOMD	315	315
	12	M 16×1,5	10	7,5	21,9	27,0	25,0	18,0	16,5	12	36,0	33	3,0	27	24	22	180	WH12LMKDSOMD	315	315
	15	M 18×1,5	11	9,0	23,9	29,0	27,5	21,5	18,5	12	39,5	37	3,0	30	30	27	244	WH15LMKDSOMD	315	315
	18	M 22×1,5	15	12,0	26,9	32,0	28,5	21,0	21,5	14	45,0	37	4,5	32	30	32	327	WH18LMKDSOMD	315	315
	22	M 26×1,5	19	17,0	31,9	41,0	35,0	27,5	24,0	16	53,0	44	3,5	41	36	36	573	WH22LMKDSOMD	160	160
	28	M 33×2,0	24	21,0	39,9	46,0	39,5	32,0	30,5	18	66,0	49	3,5	50	46	41	1017	WH28LMKDSOMD	160	160
	35	M 42×2,0	30	27,0	49,9	57,0	46,5	36,0	35,5	20	76,0	58	3,5	60	55	50	1512	WH35LMKDSOMD	160	160
	42	M 48×2,0	36	34,0	55,9	64,0	51,5	40,5	40,5	22	87,0	63	3,5	70	60	60	2217	WH42LMKDSOMD	160	160
S ⁴⁾	06	M 12×1,5	4	6,0	17,0	22,0	23,5	16,5	14,0	12	30,0	31	3,0	22	19	17	104	WH06SMKDSOMD	400	400
	08	M 14×1,5	5	6,0	18,9	22,5	23,5	16,5	14,0	12	30,0	31	3,0	22	19	19	110	WH08SMKDSOMD	400	400
	10	M 16×1,5	7	7,5	21,9	27,0	26,0	18,5	16,5	12	36,0	35	3,0	27	24	22	186	WH10SMKDSOMD	400	400
	12	M 18×1,5	8	9,0	23,9	29,0	27,5	20,0	18,5	12	39,5	36	3,0	27	27	24	246	WH12SMKDSOMD	400	400
	14	M 20×1,5	10	10,0		32,0	30,5	22,5	20,0	14	43,5	40	3,0	32	30	27	322	WH14SMKDSOMD		400
	16	M 22×1,5	12	12,0	26,9	32,0	30,5	22,0	21,5	14	45,0	40	4,5	32	30	30	327	WH16SMKDSOMD	315	315
	20	M 27×2,0	16	16,0	32,9	41,0	37,0	26,5	24,0	16	53,0	48	3,5	41	36	36	598	WH20SMKDSOMD	315	315
	25	M 33×2,0	20	21,0	39,9	46,0	43,5	31,5	30,5	18	66,0	56	3,5	50	46	46	1055	WH25SMKDSOMD	250	250
	30	M 42×2,0	25	27,0	49,9	57,0	50,5	37,0	35,5	20	76,0	64	3,5	60	55	50	1572	WH30SMKDSOMD	160	160
	38	M 48×2,0	32	34,0	55,9	64,0	57,5	41,5	40,5	22	87,0	72	3,5	70	60	60	2317	WH38SMKDSOMD	160	160

1) Pressione indicata = Articolo disponibile

3) L = Serie leggera; 4) S = Serie pesante

$$\frac{PN \text{ (bar)}}{10} = PN \text{ (MPa)}$$

Consegna senza dado né anello. Per informazioni sull'ordinazione di raccordi completi o sui materiali di tenuta alternativi vedere pag. 17.

Suffissi codice di ordinazione			
Materiale	Suffisso superficie e materiale	Esempio	Materiale di tenuta standard (non occorre suffisso aggiuntivo)
Acciaio, zincato, esente da CromoVI	CF	WH16SMKDSOMDCF	NBR
Acciaio inossidabile	71	WH16SMKDSOMD71	VIT/PTFE

*Aggiungere i suffissi qui di seguito in base al materiale e alla superficie richiesti.

Acciaio inossidabile disponibile solo con anello di tenuta KD!
Sostituire KDS con KD nel codice di ordinazione.

WH-M Gomito banjo per alte pressioni

Estremità conica EO 24° / Filettatura maschio metrica con anello di tenuta metallico

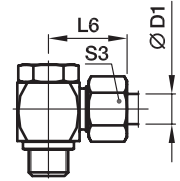
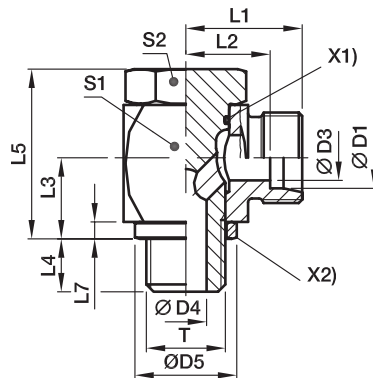

X1) O-ring OR
X2) Anello di tenuta DKA

Serie	D1	T	D3	D4	D5	L1	L2	L3	L4	L5	L6	L7	S1	S2	S3	Peso g/1 pezzo	Codice di ordinazione*	PN (bar) ¹⁾		
																		CF	71	
L ³⁾	06	M 10×1,0	4	4,5	14	19,0	12,0	10,5	8	24,0	27	2,5	17	17	14	54	WH06LMOMD	250	250	
	08	M 12×1,5	6	6,0	17	21,5	14,5	14,0	12	30,0	29	3,0	22	19	17	97	WH08LMOMD	250	250	
	10	M 14×1,5	8	6,0	19	22,5	15,5	14,0	12	30,0	30	3,0	22	19	19	104	WH10LMOMD	250	250	
	12	M 16×1,5	10	7,5	21	25,0	18,0	16,5	12	36,0	33	3,0	27	24	22	180	WH12LMOMD	250	250	
	15	M 18×1,5	11	9,0	23	27,5	21,5	18,5	12	39,5	37	3,0	30	27	27	243	WH15LMOMD	250	250	
	18	M 22×1,5	15	12,0	27	28,5	21,0	21,5	14	45,0	37	4,5	32	30	32	326	WH18LMOMD	250	250	
	22	M 26×1,5	19	17,0	31	35,0	27,5	24,0	16	53,0	44	3,5	41	36	36	574	WH22LMOMD	160	160	
	28	M 33×2,0	24	21,0	39	39,5	32,0	30,5	18	66,0	49	3,5	50	46	41	1016	WH28LMOMD	160	160	
	35	M 42×2,0	30	27,0	49	46,5	36,0	35,5	20	76,0	58	3,5	60	55	50	1512	WH35LMOMD	160	160	
	42	M 48×2,0	36	34,0	55	51,5	40,5	40,5	22	87,0	63	3,5	70	60	60	2216	WH42LMOMD	160	160	
	S ⁴⁾	06	M 12×1,5	4	6,0	17	23,5	16,5	14,0	12	30,0	31	3,0	22	19	17	104	WH06SMOMD	315	315
		08	M 14×1,5	5	6,0	19	23,5	16,5	14,0	12	30,0	31	3,0	22	19	19	111	WH08SMOMD	315	315
		10	M 16×1,5	7	7,5	21	26,0	18,5	16,5	12	36,0	35	3,0	27	24	22	186	WH10SMOMD	315	315
		12	M 18×1,5	8	9,0	23	27,5	20,0	18,5	12	39,5	36	3,0	27	27	24	246	WH12SMOMD	315	315
14		M 20×1,5	10	10,0	25	30,5	22,5	20,0	14	43,5	40	3,0	32	30	27	320	WH14SMOMD	315	315	
16		M 22×1,5	12	12,0	27	30,5	22,0	21,5	14	45,0	40	4,5	32	30	30	326	WH16SMOMD	315	315	
20		M 27×2,0	16	16,0	32	37,0	26,5	24,0	16	53,0	48	3,5	41	36	36	596	WH20SMOMD	160	160	
25		M 33×2,0	20	21,0	39	43,5	31,5	30,5	18	66,0	56	3,5	50	46	46	1055	WH25SMOMD	160	160	
30		M 42×2,0	25	27,0	49	50,5	37,0	35,5	20	76,0	64	3,5	60	55	50	1572	WH30SMOMD	160	160	
38		M 48×2,0	32	34,0	55	57,5	41,5	40,5	22	87,0	72	3,5	70	60	60	2316	WH38SMOMD	160	160	

1) Pressione indicata = Articolo disponibile

3) L = Serie leggera; 4) S = Serie pesante

$$\frac{\text{PN (bar)}}{10} = \text{PN (MPa)}$$

Consegna senza dado né anello. Per informazioni sull'ordinazione di raccordi completi o sui materiali di tenuta alternativi vedere pag. 17.

Suffissi codice di ordinazione			
Materiale	Suffisso superficie e materiale	Esempio	Materiale di tenuta standard (non occorre suffisso aggiuntivo)
Acciaio, zincato, esente da CromoVI	CF	WH16SMOMDCF	NBR
Acciaio inossidabile	71	WH16SMOMD71	VIT

*Aggiungere i **suffissi** qui di seguito in base al materiale e alla superficie richiesti.

WH-R-KDS Gomito banjo per alte pressioni

Estremità conica EO 24° / Filettatura maschio BSPP con anello di tenuta in gomma

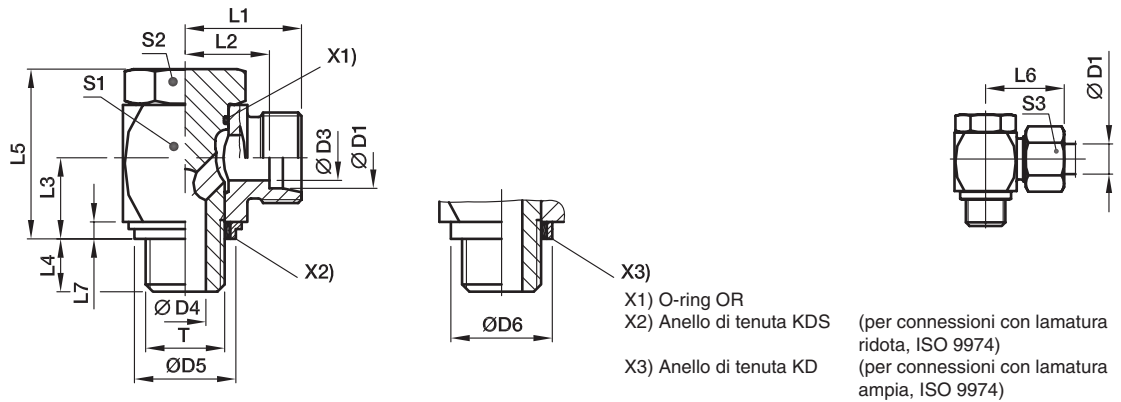

Serie	D1	T	D3	D4	D5 KDS	D6 KD	L1	L2	L3	L4	L5	L6	L7	S1	S2	S3	Peso g/1 pezzo	Codice di ordinazione*		PN (bar) ¹⁾	
																		CF	71	CF	71
L ³⁾	06	G 1/8 A	4	4,5	14,9	17	19,0	12,0	10,5	8	24	27	2,5	17	17	14	53	WH06LRKDSOMD	315	315	
	08	G 1/4 A	6	6,0	18,9	22	21,5	14,5	14,0	12	30	29	3,0	22	19	17	101	WH08LRKDSOMD	315	315	
	10	G 1/4 A	8	6,0	18,9	22	22,5	15,5	14,0	12	30	30	3,0	22	19	19	102	WH10LRKDSOMD	315	315	
	12	G 3/8 A	10	7,5	21,9	27	25,0	18,0	16,5	12	36	33	3,0	27	24	22	181	WH12LRKDSOMD	315	315	
	15	G 1/2 A	12	11,0	26,9	32	28,5	21,5	21,5	14	45	37	4,5	32	30	27	312	WH15LRKDSOMD	315	315	
	18	G 1/2 A	15	11,0	26,9	32	28,5	21,0	21,5	14	45	37	4,5	32	30	32	319	WH18LRKDSOMD	315	315	
	22	G 3/4 A	19	17,0	32,9	41	35,0	27,5	24,0	16	53	44	3,5	41	36	36	578	WH22LRKDSOMD	160	160	
	28	G 1 A	24	21,0	39,9	46	39,5	32,0	30,5	18	66	49	3,5	50	46	41	1035	WH28LRKDSOMD	160	160	
	35	G 1 1/4 A	30	27,0	49,9	57	46,5	36,0	35,5	20	76	58	3,5	60	55	50	1499	WH35LRKDSOMD	160	160	
	42	G 1 1/2 A	36	34,0	55,9	64	51,5	40,5	40,5	22	87	63	3,5	70	60	60	2196	WH42LRKDSOMD	160	160	
S ⁴⁾	06	G 1/4 A	4	6,0	18,9	22	23,5	16,5	14,0	12	30	31	3,0	22	19	17	107	WH06SRKDSOMD	400	400	
	08	G 1/4 A	5	6,0	18,9	22	23,5	16,5	14,0	12	30	31	3,0	22	19	19	107	WH08SRKDSOMD	400	400	
	10	G 3/8 A	7	7,5	21,9	27	26,0	18,5	16,5	12	36	35	3,0	27	24	22	188	WH10SRKDSOMD	400	400	
	12	G 3/8 A	8	7,5	21,9	27	26,0	18,5	16,5	12	36	35	3,0	27	24	24	190	WH12SRKDSOMD	400	400	
	14	G 1/2 A	10	11,0	26,9	32	30,5	22,5	21,5	15	45	40	4,5	32	30	27	320	WH14SRKDSOMD	400	400	
	16	G 1/2 A	12	11,0	26,9	32	30,5	22,0	21,5	14	45	40	4,5	32	30	30	324	WH16SRKDSOMD	315	315	
	20	G 3/4 A	16	17,0	32,9	41	37,0	26,5	24,0	16	53	48	3,5	41	36	36	588	WH20SRKDSOMD	315	315	
	25	G 1 A	20	21,0	39,9	46	43,5	31,5	30,5	18	66	56	3,5	50	46	46	1073	WH25SRKDSOMD	250	250	
	30	G 1 1/4 A	25	27,0	49,9	57	50,5	37,0	35,5	20	76	64	3,5	60	55	50	1559	WH30SRKDSOMD	160	160	
	38	G 1 1/2 A	32	34,0	55,9	64	57,5	41,5	40,5	22	87	72	3,5	70	60	60	2296	WH38SRKDSOMD	160	160	

1) Pressione indicata = Articolo disponibile

3) L = Serie leggera; 4) S = Serie pesante

$$\frac{PN \text{ (bar)}}{10} = PN \text{ (MPa)}$$

Consegna senza dado né anello. Per informazioni sull'ordinazione di raccordi completi o sui materiali di tenuta alternativi vedere pag. I7.

*Aggiungere i suffissi qui di seguito in base al materiale e alla superficie richiesti.

Suffissi codice di ordinazione			
Materiale	Suffisso superficie e materiale	Esempio	Materiale di tenuta standard (non occorre suffisso aggiuntivo)
Acciaio, zincato, esente da CromoVI	CF	WH16SRKDSOMDCF	NBR
Acciaio inossidabile	71	WH16SRKDOMD71	VIT/PTFE

Acciaio inossidabile disponibile solo con anello di tenuta KD!
 Sostituire KDS con KD nel codice di ordinazione.

WH-R Gomito banjo per alte pressioni

Estremità conica EO 24° / Filettatura maschio BSPP con anello di tenuta metallico

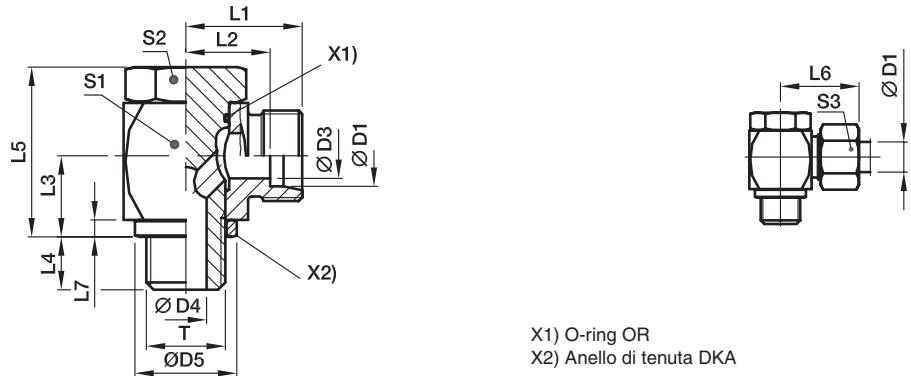

X1) O-ring OR
X2) Anello di tenuta DKA

Serie	D1	T	D3	D4	D5	L1	L2	L3	L4	L5	L6	L7	S1	S2	S3	Peso g/1 pezzo	Codice di ordinazione*	PN (bar) ¹⁾		
																		CF	71	MS
L ³⁾	06	G 1/8 A	4	4,5	14	19,0	12,0	10,5	8	24	27	2,5	17	17	14	53	WH06LROMD	250	250	160
	08	G 1/4 A	6	6,0	18	21,5	14,5	14,0	12	30	29	3,0	22	19	17	101	WH08LROMD	250	250	160
	10	G 1/4 A	8	6,0	18	22,5	15,5	14,0	12	30	30	3,0	22	19	19	102	WH10LROMD	250	250	160
	12	G 3/8 A	10	7,5	22	25,0	18,0	16,5	12	36	33	3,0	27	24	22	181	WH12LROMD	250	250	160
	15	G 1/2 A	12	11,0	26	28,5	21,5	21,5	14	45	37	4,5	32	30	27	311	WH15LROMD	250	250	160
	18	G 1/2 A	15	11,0	26	28,5	21,0	21,5	14	45	37	4,5	32	30	32	319	WH18LROMD	250	250	160
	22	G 3/4 A	19	17,0	32	35,0	27,5	24,0	16	53	44	3,5	41	36	36	577	WH22LROMD	160	160	
	28	G 1 A	24	21,0	39	39,5	32,0	30,5	18	66	49	3,5	50	46	41	1034	WH28LROMD	160	160	
	35	G 1 1/4 A	30	27,0	57	46,5	36,0	35,5	20	76	58	3,5	60	55	50	1500	WH35LROMD	160	160	
	42	G 1 1/2 A	36	34,0	55	51,5	40,5	40,5	22	87	63	3,5	70	60	60	2195	WH42LROMD	160	160	
S ⁴⁾	06	G 1/4 A	4	6,0	18	23,5	16,5	14,0	12	30	31	3,0	22	19	17	107	WH06SROMD	315	315	200
	08	G 1/4 A	5	6,0	18	23,5	16,5	14,0	12	30	31	3,0	22	19	19	107	WH08SROMD	315	315	200
	10	G 3/8 A	7	7,5	22	26,0	18,5	16,5	12	36	35	3,0	27	24	22	188	WH10SROMD	315	315	200
	12	G 3/8 A	8	7,5	22	26,0	18,5	16,5	12	36	35	3,0	27	24	24	190	WH12SROMD	315	315	200
	14	G 1/2 A	10	11,0	26	30,5	22,5	21,5	14	45	40	4,5	32	30	27	320	WH14SROMD	315	315	
	16	G 1/2 A	12	11,0	26	30,5	22,0	21,5	14	45	40	4,5	32	30	30	317	WH16SROMD	315	315	
	20	G 3/4 A	16	17,0	32	37,0	26,5	24,0	16	53	48	3,5	41	36	36	587	WH20SROMD	160	160	
	25	G 1 A	20	21,0	39	43,5	31,5	30,5	18	66	56	3,5	50	46	46	1072	WH25SROMD	160	160	
	30	G 1 1/4 A	25	27,0	49	50,5	37,0	35,5	20	76	64	3,5	60	55	50	1560	WH30SROMD	160	160	
	38	G 1 1/2 A	32	34,0	55	57,5	41,5	40,5	22	87	72	3,5	70	60	60	2295	WH38SROMD	160	160	

¹⁾ Pressione indicata = Articolo disponibile

³⁾ L = Serie leggera; ⁴⁾ S = Serie pesante

$$\frac{PN \text{ (bar)}}{10} = PN \text{ (MPa)}$$

Consegna senza dado né anello. Per informazioni sull'ordinazione di raccordi completi o sui materiali di tenuta alternativi vedere pag. 17.

Suffissi codice di ordinazione			
Materiale	Suffisso superficie e materiale	Esempio	Materiale di tenuta standard (non occorre suffisso aggiuntivo)
Acciaio, zincato, esente da CromoVI	CF	WH16SROMDCF	NBR
Acciaio inossidabile	71	WH16SROMD71	VIT
Ottone	MS	WH18LROMDMS	NBR

*Aggiungere i suffissi qui di seguito in base al materiale e alla superficie richiesti.

TH-M-KDS T banjo per alte pressioni

Estremità conica EO 24° / Filettatura maschio metrica con anello di tenuta in gomma

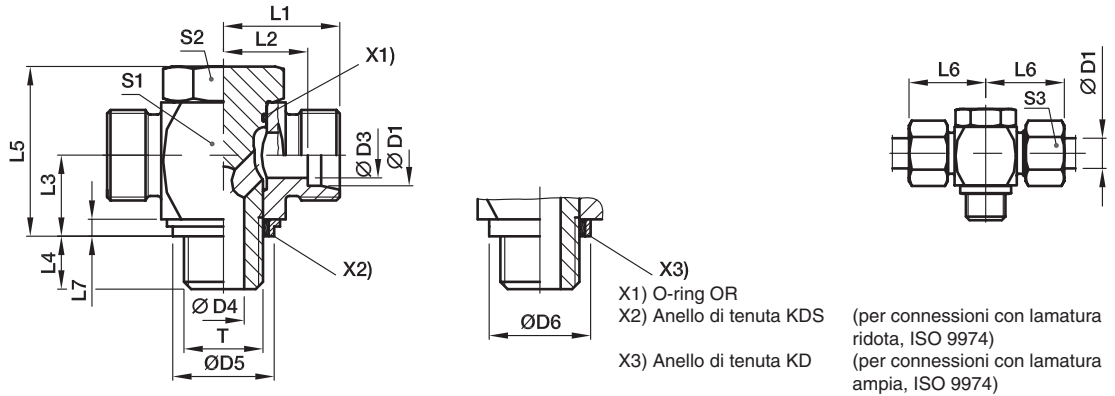

Serie	D1	T	D3	D4	D5 KDS	D6 KD	L1	L2	L3	L4	L5	L6	L7	S1	S2	S3	Peso g/1 pezzo	Codice di ordinazione*	PN (bar) ¹⁾	
																			CF	71
L ³⁾	06	M 10×1,0	4	4,5	14,9	17,0	19,0	12,0	10,5	8	24,0	27	2,5	17	17	14	59	TH06LMKDSOMD	315	315
	08	M 12×1,5	6	6,0	17,0	22,0	21,5	14,5	14,0	12	30,0	29	3,0	22	19	17	104	TH08LMKDSOMD	315	315
	10	M 14×1,5	8	6,0	18,9	22,5	22,5	15,5	14,0	12	30,0	30	3,0	22	19	19	112	TH10LMKDSOMD	315	315
	12	M 16×1,5	10	7,5	21,9	27,0	25,0	18,0	16,5	12	36,0	33	3,0	27	24	22	192	TH12LMKDSOMD	315	315
	15	M 18×1,5	11	9,0	23,9	29,0	27,5	21,5	18,5	12	39,5	37	3,0	30	27	27	258	TH15LMKDSOMD	315	315
	18	M 22×1,5	15	12,0	26,9	32,0	28,5	21,0	21,5	14	45,0	37	4,5	32	30	32	337	TH18LMKDSOMD	315	315
	22	M 26×1,5	19	17,0	31,9	41,0	35,0	27,5	24,0	16	53,0	44	3,5	41	36	36	589	TH22LMKDSOMD	160	160
	28	M 33×2,0	24	21,0	39,9	46,0	39,5	32,0	30,5	18	66,0	49	3,5	50	46	41	1072	TH28LMKDSOMD	160	160
	35	M 42×2,0	30	27,0	49,9	57,0	46,5	36,0	35,5	20	76,0	58	3,5	60	55	50	1778	TH35LMKDSOMD	160	160
	42	M 48×2,0	36	34,0	55,9	64,0	51,5	40,5	40,5	22	87,0	63	3,5	70	60	60	2566	TH42LMKDSOMD	160	160
S ⁴⁾	06	M 12×1,5	4	6,0	17,0	22,0	23,5	16,5	14,0	12	30,0	31	3,0	22	19	17	112	TH06SMKDSOMD	400	400
	08	M 14×1,5	5	6,0	18,9	22,5	23,5	16,5	14,0	12	30,0	31	3,0	22	19	19	123	TH08SMKDSOMD	400	400
	10	M 16×1,5	7	7,5	21,9	27,0	26,0	18,5	16,5	12	36,0	35	3,0	27	24	22	200	TH10SMKDSOMD	400	400
	12	M 18×1,5	8	9,0	23,9	29,0	27,5	20,0	18,5	12	39,5	36	3,0	27	27	24	261	TH12SMKDSOMD	400	400
	14	M 20×1,5	10	10,0		32,0	30,5	22,5	20,0	14	43,5	40	3,0	32	30	27	334	TH14SMKDSOMD		400
	16	M 22×1,5	12	12,0	26,9	32,0	30,5	22,0	21,5	14	45,0	40	4,5	32	30	30	351	TH16SMKDSOMD	315	315
	20	M 27×2,0	16	16,0	32,9	41,0	37,0	26,5	24,0	16	53,0	48	3,5	41	36	36	629	TH20SMKDSOMD	315	315
	25	M 33×2,0	20	21,0	39,9	46,0	43,5	31,5	30,5	18	66,0	56	3,5	50	46	46	1106	TH25SMKDSOMD	250	250
	30	M 42×2,0	25	27,0	49,9	57,0	50,5	37,0	35,5	20	76,0	64	3,5	60	55	50	1843	TH30SMKDSOMD	160	160
	38	M 48×2,0	32	34,0	55,9	64,0	57,5	41,5	40,5	22	87,0	72	3,5	70	60	60	2744	TH38SMKDSOMD	160	160

1) Pressione indicata = Articolo disponibile

3) L = Serie leggera; 4) S = Serie pesante

$$\frac{PN(\text{bar})}{10} = PN(\text{MPa})$$

Consegna senza dado né anello. Per informazioni sull'ordinazione di raccordi completi o sui materiali di tenuta alternativi vedere pag. 17.

*Aggiungere i suffissi qui di seguito in base al materiale e alla superficie richiesti.

Suffissi codice di ordinazione			
Materiale	Suffisso superficie e materiale	Esempio	Materiale di tenuta standard (non occorre suffisso aggiuntivo)
Acciaio, zincato, esente da CromoVI	CF	TH16SMKDSOMDCF	NBR
Acciaio inossidabile	71	TH16SMKDOMD71	VIT/PTFE

Acciaio inossidabile disponibile solo con anello di tenuta KD!
Sostituire KDS con KD nel codice di ordinazione.

TH-M T banjo per alte pressioni

Estremità conica EO 24° / Filettatura maschio metrica con anello di tenuta metallico

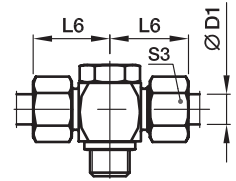
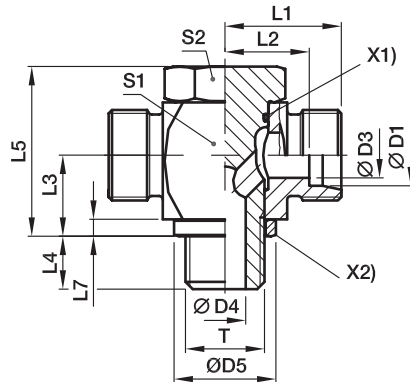

X1) O-ring OR
X2) Anello di tenuta DKA

Serie	D1	T	D3	D4	D5	L1	L2	L3	L4	L5	L6	L7	S1	S2	S3	Peso g/1 pezzo	Codice di ordinazione*	PN (bar) ¹⁾	
																		CF	71
L ³⁾	06	M 10×1,0	4	4,5	14	19,0	12,0	10,5	8	24,0	27	2,5	17	17	14	58	TH06LMOMD	250	250
	08	M 12×1,5	6	6,0	17	21,5	14,5	14,0	12	30,0	29	3,0	22	19	17	104	TH08LMOMD	250	250
	10	M 14×1,5	8	6,0	19	22,5	15,5	14,0	12	30,0	30	3,0	22	19	19	112	TH10LMOMD	250	250
	12	M 16×1,5	10	7,5	21	25,0	18,0	16,5	12	36,0	33	3,0	27	24	22	191	TH12LMOMD	250	250
	15	M 18×1,5	11	9,0	23	27,5	21,5	18,5	12	39,5	37	3,0	30	27	27	258	TH15LMOMD	250	250
	18	M 22×1,5	15	12,0	27	28,5	21,0	21,5	14	45,0	37	4,5	32	30	32	337	TH18LMOMD	250	250
	22	M 26×1,5	19	17,0	31	35,0	27,5	24,0	16	53,0	44	3,5	41	36	36	590	TH22LMOMD	160	160
	28	M 33×2,0	24	21,0	39	39,5	32,0	30,5	18	66,0	49	3,5	50	46	41	1072	TH28LMOMD	160	160
	35	M 42×2,0	30	27,0	49	46,5	36,0	35,5	20	76,0	58	3,5	60	55	50	1778	TH35LMOMD	160	160
	42	M 48×2,0	36	34,0	55	51,5	40,5	40,5	22	87,0	63	3,5	70	60	60	2565	TH42LMOMD	160	160
S ⁴⁾	06	M 12×1,5	4	6,0	17	23,5	16,5	14,0	12	30,0	31	3,0	22	19	17	112	TH06SMOMD	315	315
	08	M 14×1,5	5	6,0	19	23,5	16,5	14,0	12	30,0	31	3,0	22	19	19	124	TH08SMOMD	315	315
	10	M 16×1,5	7	7,5	21	26,0	18,5	16,5	12	36,0	35	3,0	27	24	22	200	TH10SMOMD	315	315
	12	M 18×1,5	8	9,0	23	27,5	20,0	18,5	12	39,5	36	3,0	27	27	24	261	TH12SMOMD	315	315
	14	M 20×1,5	10	10,0	25	30,5	22,5	20,0	14	43,5	40	3,0	32	30	27	334	TH14SMOMD	315	315
	16	M 22×1,5	12	12,0	27	30,5	22,0	21,5	14	45,0	40	4,5	32	30	30	350	TH16SMOMD	315	315
	20	M 27×2,0	16	16,0	32	37,0	26,5	24,0	16	53,0	48	3,5	41	36	36	628	TH20SMOMD	160	160
	25	M 33×2,0	20	21,0	39	43,5	31,5	30,5	18	66,0	56	3,5	50	46	46	1106	TH25SMOMD	160	160
	30	M 42×2,0	25	27,0	49	50,5	37,0	35,5	20	76,0	64	3,5	60	55	50	1843	TH30SMOMD	160	160
	38	M 48×2,0	32	34,0	55	57,5	41,5	40,5	22	87,0	72	3,5	70	60	60	2741	TH38SMOMD	160	160

1) Pressione indicata = Articolo disponibile

3) L = Serie leggera; 4) S = Serie pesante

$\frac{PN \text{ (bar)}}{10} = PN \text{ (MPa)}$

Consegna senza dado né anello. Per informazioni sull'ordinazione di raccordi completi o sui materiali di tenuta alternativi vedere pag. 17.

*Aggiungere i suffissi qui di seguito in base al materiale e alla superficie richiesti.

Suffissi codice di ordinazione			
Materiale	Suffisso superficie e materiale	Esempio	Materiale di tenuta standard (non occorre suffisso aggiuntivo)
Acciaio, zincato, esente da CromoVI	CF	TH16SMOMDCF	NBR
Acciaio inossidabile	71	TH16SMOMD71	VIT

TH-R-KDS T banjo per alte pressioni

Estremità conica EO 24° / Filettatura maschio BSPP con anello di tenuta in gomma

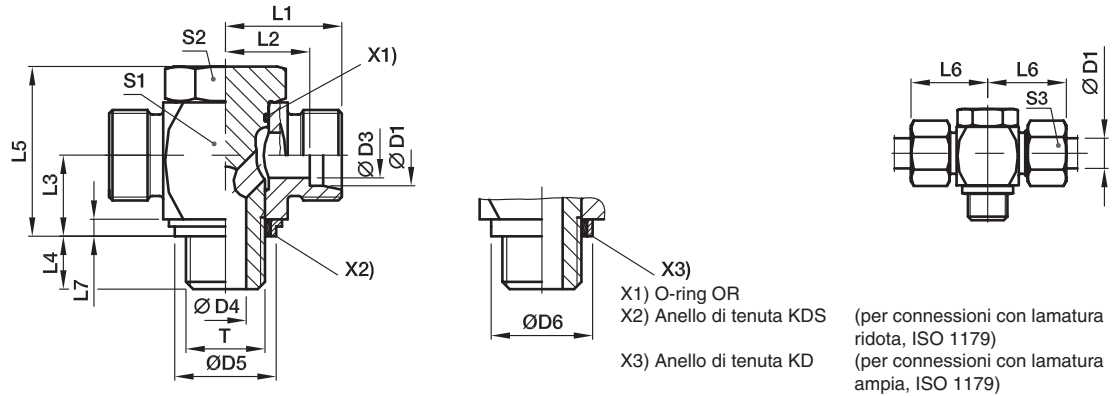

Serie	D1	T	D3	D4	D5 KDS	D6 KD	L1	L2	L3	L4	L5	L6	L7	S1	S2	S3	Peso g/1 pezzo	Codice di ordinazione*		PN (bar) ¹⁾	
																		CF	71	CF	71
L ³⁾	06	G 1/8 A	4	4,5	14,9	17	19,0	12,0	10,5	8	24	27	2,5	17	17	14	58	TH06LRKDSOMD	315	315	
	08	G 1/4 A	6	6,0	18,9	22	21,5	14,5	14,0	12	30	29	3,0	22	19	17	108	TH08LRKDSOMD	315	315	
	10	G 1/4 A	8	6,0	18,9	22	22,5	15,5	14,0	12	30	30	3,0	22	19	19	110	TH10LRKDSOMD	315	315	
	12	G 3/8 A	10	7,5	21,9	27	25,0	18,0	16,5	12	36	33	3,0	27	24	22	193	TH12LRKDSOMD	315	315	
	15	G 1/2 A	12	11,0	26,9	32	28,5	21,5	21,5	14	45	37	4,5	32	30	27	321	TH15LRKDSOMD	315	315	
	18	G 1/2 A	15	11,0	26,9	32	28,5	21,0	21,5	14	45	37	4,5	32	30	32	329	TH18LRKDSOMD	315	315	
	22	G 3/4 A	19	17,0	32,9	41	35,0	27,5	24,0	16	53	44	3,5	41	36	36	585	TH22LRKDSOMD	160	160	
	28	G 1 A	24	21,0	39,9	46	39,5	32,0	30,5	18	66	49	3,5	50	46	41	1090	TH28LRKDSOMD	160	160	
	35	G 1 1/4 A	30	27,0	49,9	57	46,5	36,0	35,5	20	76	58	3,5	60	55	50	1765	TH35LRKDSOMD	160	160	
	42	G 1 1/2 A	36	34,0	55,9	64	51,5	40,5	40,5	22	87	63	3,5	70	60	60	2545	TH42LRKDSOMD	160	160	
S ⁴⁾	06	G 1/4 A	4	6,0	18,9	22	23,5	16,5	14,0	12	30	31	3,0	22	19	17	116	TH06SRKDSOMD	400	400	
	08	G 1/4 A	5	6,0	18,9	22	23,5	16,5	14,0	12	30	31	3,0	22	19	19	121	TH08SRKDSOMD	400	400	
	10	G 3/8 A	7	7,5	21,9	27	26,0	18,5	16,5	12	36	35	3,0	27	24	22	201	TH10SRKDSOMD	400	400	
	12	G 3/8 A	8	7,5	21,9	27	26,0	18,5	16,5	12	36	35	3,0	27	24	24	207	TH12SRKDSOMD	400	400	
	14	G 1/2 A	10	11,0	26,9	32	30,5	22,5	21,5	15	45	40	4,5	32	30	27	338	TH14SRKDSOMD	400	400	
	16	G 1/2 A	12	11,0	26,9	32	30,5	22,0	21,5	14	45	40	4,5	32	30	30	350	TH16SRKDSOMD	315	315	
	20	G 3/4 A	16	17,0	32,9	41	37,0	26,5	24,0	16	53	48	3,5	41	36	36	620	TH20SRKDSOMD	315	315	
	25	G 1 A	20	21,0	39,9	46	43,5	31,5	30,5	18	66	56	3,5	50	46	46	1124	TH25SRKDSOMD	250	250	
	30	G 1 1/4 A	25	27,0	49,9	57	50,5	37,0	35,5	20	76	64	3,5	60	55	50	1830	TH30SRKDSOMD	160	160	
	38	G 1 1/2 A	32	34,0	55,9	64	57,5	41,5	40,5	22	87	72	3,5	70	60	60	2721	TH38SRKDSOMD	160	160	

1) Pressione indicata = Articolo disponibile

3) L = Serie leggera; 4) S = Serie pesante

$$\frac{PN(\text{bar})}{10} = PN(\text{MPa})$$

Consegna senza dado né anello. Per informazioni sull'ordinazione di raccordi completi o sui materiali di tenuta alternativi vedere pag. I7.

*Aggiungere i suffissi qui di seguito in base al materiale e alla superficie richiesti.

Suffissi codice di ordinazione			
Materiale	Suffisso superficie e materiale	Esempio	Materiale di tenuta standard (non occorre suffisso aggiuntivo)
Acciaio, zincato, esente da CromoVI	CF	TH16SRKDSOMDCF	NBR
Acciaio inossidabile	71	TH16SRKDOMD71	VIT/PTFE

Acciaio inossidabile disponibile solo con anello di tenuta KD!
Sostituire KDS con KD nel codice di ordinazione.

TH-R T banjo per alte pressioni

Estremità conica EO 24° / Filettatura maschio BSPP con anello di tenuta metallico

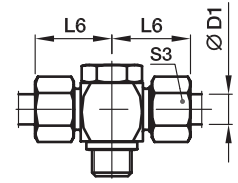
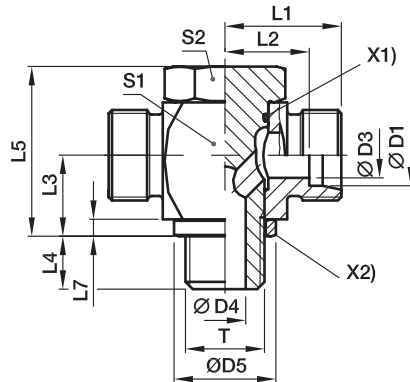

X1) O-ring OR
X2) Anello di tenuta DKA

Serie	D1	T	D3	D4	D5	L1	L2	L3	L4	L5	L6	L7	S1	S2	S3	Peso g/1 pezzo	Codice di ordinazione*	PN (bar) ¹⁾		
																		CF	71	
L ³⁾	06	G 1/8 A	4	4,5	14	19,0	12,0	10,5	8	24	27	2,5	17	17	14	58	TH06LROMD	250	250	
	08	G 1/4 A	6	6,0	18	21,5	14,5	14,0	12	30	29	3,0	22	19	17	108	TH08LROMD	250	250	
	10	G 1/4 A	8	6,0	18	22,5	15,5	14,0	12	30	30	3,0	22	19	19	110	TH10LROMD	250	250	
	12	G 3/8 A	10	7,5	22	25,0	18,0	16,5	12	36	33	3,0	27	24	22	193	TH12LROMD	250	250	
	15	G 1/2 A	12	11,0	26	28,5	21,5	21,5	14	45	37	4,5	32	30	27	321	TH15LROMD	250	250	
	18	G 1/2 A	15	11,0	26	28,5	21,0	21,5	14	45	37	4,5	32	30	32	329	TH18LROMD	250	250	
	22	G 3/4 A	19	17,0	32	35,0	27,5	24,0	16	53	44	3,5	41	36	36	584	TH22LROMD	160	160	
	28	G 1 A	24	21,0	39	39,5	32,0	30,5	18	66	49	3,5	50	46	41	1090	TH28LROMD	160	160	
	35	G 1 1/4 A	30	27,0	57	46,5	36,0	35,5	20	76	58	3,5	60	55	50	1766	TH35LROMD	160	160	
	42	G 1 1/2 A	36	34,0	55	51,5	40,5	40,5	22	87	63	3,5	70	60	60	2544	TH42LROMD	160	160	
	S ⁴⁾	06	G 1/4 A	4	6,0	18	23,5	16,5	14,0	12	30	31	3,0	22	19	17	116	TH06SROMD	315	315
		08	G 1/4 A	5	6,0	18	23,5	16,5	14,0	12	30	31	3,0	22	19	19	121	TH08SROMD	315	315
		10	G 3/8 A	7	7,5	22	26,0	18,5	16,5	12	36	35	3,0	27	24	22	201	TH10SROMD	315	315
		12	G 3/8 A	8	7,5	22	26,0	18,5	16,5	12	36	35	3,0	27	24	24	207	TH12SROMD	315	315
14		G 1/2 A	10	11,0	26	30,5	22,5	21,5	14	45	40	4,5	32	30	27	343	TH14SROMD	315	315	
16		G 1/2 A	12	11,0	26	30,5	22,0	21,5	14	45	40	4,5	32	30	30	350	TH16SROMD	315	315	
20		G 3/4 A	16	17,0	32	37,0	26,5	24,0	16	53	48	3,5	41	36	36	618	TH20SROMD	160	160	
25		G 1 A	20	21,0	39	43,5	31,5	30,5	18	66	56	3,5	50	46	46	1124	TH25SROMD	160	160	
30		G 1 1/4 A	25	27,0	49	50,5	37,0	35,5	20	76	64	3,5	60	55	50	1831	TH30SROMD	160	160	
38		G 1 1/2 A	32	34,0	55	57,5	41,5	40,5	22	87	72	3,5	70	60	60	2720	TH38SROMD	160	160	

¹⁾ Pressione indicata = Articolo disponibile

³⁾ L = Serie leggera; ⁴⁾ S = Serie pesante

$$\frac{\text{PN (bar)}}{10} = \text{PN (MPa)}$$

Consegna senza dado né anello. Per informazioni sull'ordinazione di raccordi completi o sui materiali di tenuta alternativi vedere pag. 17.

Suffissi codice di ordinazione			
Materiale	Suffisso superficie e materiale	Esempio	Materiale di tenuta standard (non occorre suffisso aggiuntivo)
Acciaio, zincato, esente da CromoVI	CF	TH16SROMDCF	NBR
Acciaio inossidabile	71	TH16SROMD71	VIT

*Aggiungere i **suffissi** qui di seguito in base al materiale e alla superficie richiesti.

SWVE-M Gomito banjo

Estremità conica EO 24° / Filettatura maschio metrica

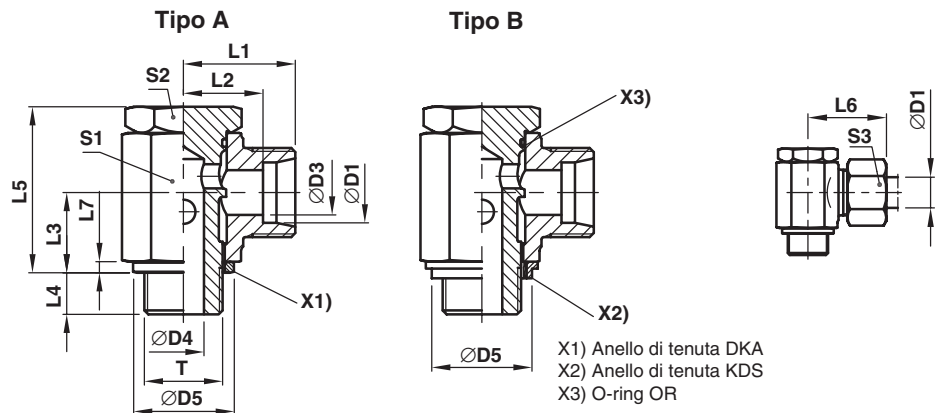

Serie	D1	T	D3	D4	DKA D5	KDS D5	L1	L2	L3	L4	L5	L6	L7	S1	S2	S3	Peso g/1 pezzo	Type A ordinazione* guarniz. metallica	Type B ordinazione* guarnizione morbida	PN (bar) ¹⁾ CF
LL ²⁾	04	M 08x1,0	3,0	3,0	12,5		14,5	10,5	8,0	6	17,0	20	2,5	12	12	10	18	SWVE04LLMOMD	—	63
	06	M 10x1,0	4,5	5,0	14,0	15	15,5	10,0	10,0	6	21,0	22	2,5	14	14	12	29	SWVE06LLMOMD	SWVE06LLMKDSOMD	63
	08	M 10x1,0	6,0	5,0	14,0	15	16,5	11,0	10,0	6	21,0	23	2,5	14	14	14	31	SWVE08LLMOMD	SWVE08LLMKDSOMD	63
L ³⁾	06	M 10x1,0	4,5	5,0	14,0	15	15,5	10,5	10,0	6	21,5	25	2,5	14	14	14	31	SWVE06LMOMD	SWVE06LMKDSOMD	160
	08	M 12x1,5	6,0	6,0	17,0	17	19,0	12,0	12,0	9	25,0	27	3,0	17	17	17	51	SWVE08LMOMD	SWVE08LMKDSOMD	160
	10	M 14x1,5	8,0	6,5	19,0	19	21,0	14,0	13,0	9	27,0	29	3,0	19	19	19	68	SWVE10LMOMD	SWVE10LMKDSOMD	160
	12	M 16x1,5	10,0	8,5	21,0	22	22,5	15,5	15,0	9	32,0	30	3,0	22	21	22	100	SWVE12LMOMD	SWVE12LMKDSOMD	100
	15	M 18x1,5	12,0	11,0	23,0	24	24,5	17,5	18,0	9	37,5	33	3,0	24	24	27	138	SWVE15LMOMD	SWVE15LMKDSOMD	100
	18	M 22x1,5	15,0	13,0	27,0	27	28,0	20,5	21,5	11	44,5	37	4,5	30	27	32	241	SWVE18LMOMD	SWVE18LMKDSOMD	100
	22	M 26x1,5	19,0	18,0	31,0	32	33,0	25,5	24,0	13	49,0	42	3,5	36	32	36	351	SWVE22LMOMD	SWVE22LMKDSOMD	100
	28	M 33x2,0	24,0	22,0	39,0	40	39,5	32,0	30,5	14	66,5	49	3,5	50	46	41		SWVE28LMOMD	SWVE28LMKDSOMD	100
	35	M 42x2,0	30,0	29,0	49,0	50	46,5	36,0	35,5	16	76,0	58	3,5	60	55	50		SWVE35LMOMD	SWVE35LMKDSOMD	100
	42	M 48x2,0	36,0	35,0	55,0	56	51,5	40,5	40,5	18	86,0	63	3,5	70	60	60		SWVE42LMOMD	SWVE42LMKDSOMD	100
S ⁴⁾	06	M 12x1,5	4,0	6,0	17,0	17	21,0	14,0	12,0	9	25,0	29	3,0	17	17	17	55	SWVE06SMOMD	SWVE06SMKDSOMD	160
	08	M 14x1,5	5,0	6,5	19,0	19	22,0	15,0	13,0	9	27,0	30	3,0	19	19	19	75	SWVE08SMOMD	SWVE08SMKDSOMD	160
	10	M 16x1,5	7,0	8,5	21,0	22	23,5	16,0	15,0	9	32,0	32	3,0	22	22	22	106	SWVE10SMOMD	SWVE10SMKDSOMD	100
	12	M 18x1,5	8,0	11,0	23,0	24	24,5	17,0	18,0	9	37,0	33	3,0	24	24	24	134	SWVE12SMOMD	SWVE12SMKDSOMD	100
	14	M 20x1,5	10,0	10,0	25,0	22	28,0	20,0	18,0	11	37,0	38	3,0	27	27	27	179	SWVE14SMOMD	—	100
	16	M 22x1,5	12,0	13,0	27,0	27	30,0	21,5	21,5	11	44,5	40	4,5	30	27	30	252	SWVE16SMOMD	SWVE16SMKDSOMD	100
	20	M 27x2,0	16,0	18,0	32,0	33	35,0	24,5	24,0	13	49,0	46	3,5	36	32	36	363	SWVE20SMOMD	SWVE20SMKDSOMD	100
	25	M 33x2,0	20,0	22,0	39,0	40	43,5	31,5	30,5	14	66,5	56	3,5	50	46	46		SWVE25SMOMD	SWVE25SMKDSOMD	100
	30	M 42x2,0	25,0	29,0	49,0	50	50,5	37,0	35,5	16	76,0	64	3,5	60	55	50		SWVE30SMOMD	SWVE30SMKDSOMD	100
	38	M 48x2,0	32,0	35,0	55,0	56	57,5	41,5	40,5	18	86,0	72	3,5	70	60	60		SWVE38SMOMD	SWVE38SMKDSOMD	100

1) Pressione indicata = Articolo disponibile

2) LL = Serie ultraleggera; 3) L = Serie leggera; 4) S = Serie pesante

$$\frac{PN \text{ (bar)}}{10} = PN \text{ (MPa)}$$

Consegna senza dado né anello. Per informazioni sull'ordinazione di raccordi completi vedere pag. 17.

Suffissi codice di ordinazione			
Materiale	Suffisso superficie e materiale	Esempio	Materiale di tenuta standard (non occorre suffisso aggiuntivo)
Acciaio, zincato, esente da CromoVI	CF	SWVE16SMOMDCF	NBR
Acciaio, zincato, esente da CromoVI	CF	SWVE16SMKDSOMDCF	NBR

*Aggiungere i suffissi qui di seguito in base al materiale e alla superficie richiesti.

SWVE-R Gomito banjo

Estremità conica EO 24° / Filettatura maschio BSPP

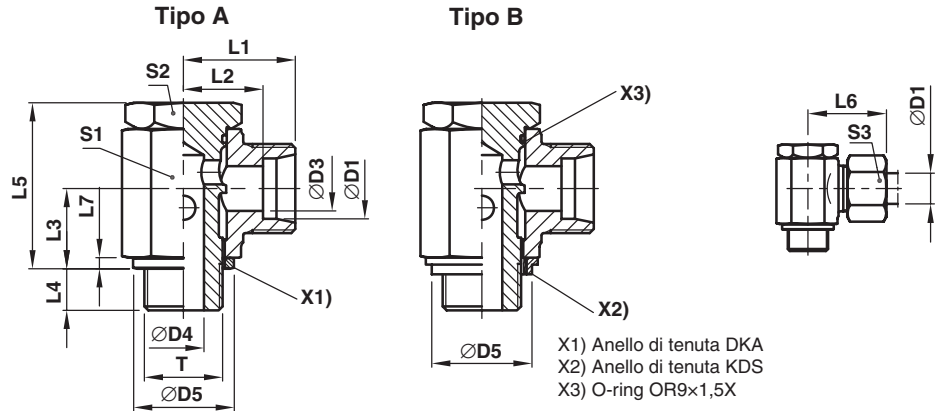

Serie	D1	T	D3	D4	DKA D5	KDS D5	L1	L2	L3	L4	L5	L6	L7	S1	S2	S3	Peso g/1 pezzo	Type A	Type B	PN (bar) ¹⁾ CF
																		ordinazione* guarniz. metallica	ordinazione* guarnizione morbida	
LL ²⁾	04	G 1/8 A	3,0	5,0	14	15	15,5	11,5	10,0	6	21,0	21	2,5	14	14	10	28	SWVE04LLROMD	SWVE04LLRKDSOMD	63
	06	G 1/8 A	4,5	5,0	14	15	15,5	10,0	10,0	6	21,5	22	2,5	14	14	12	28	SWVE06LLROMD	SWVE06LLRKDSOMD	63
	08	G 1/8 A	6,0	5,0	14	15	16,5	11,0	10,0	6	21,0	23	2,5	14	14	14	30	SWVE08LLROMD	SWVE08LLRKDSOMD	63
L ³⁾	06	G 1/8 A	4,0	5,0	14	15	17,5	10,5	10,0	6	21,0	25	2,5	14	14	14	31	SWVE06LROMD	SWVE06LRKDSOMD	160
	08	G 1/4 A	6,0	6,5	18	19	20,0	13,0	13,0	9	27,0	28	3,0	19	19	17	65	SWVE08LROMD	SWVE08LRKDSOMD	160
	10	G 1/4 A	8,0	6,5	18	19	21,0	14,0	13,0	9	27,0	29	3,0	19	19	19	66	SWVE10LROMD	SWVE10LRKDSOMD	160
	12	G 3/8 A	10,0	8,5	22	22	22,5	15,5	15,0	9	32,0	30	3,0	22	22	22	102	SWVE12LROMD	SWVE12LRKDSOMD	100
	15	G 1/2 A	12,0	11,0	26	27	26,0	19,0	18,0	11	37,5	34	4,5	27	27	27	171	SWVE15LROMD	SWVE15LRKDSOMD	100
	18	G 1/2 A	15,0	13,0	26	27	28,0	20,5	21,5	11	44,5	37	4,5	30	27	32	249	SWVE18LROMD	SWVE18LRKDSOMD	100
	22	G 3/4 A	19,0	18,0	32	33	33,0	25,5	24,0	13	49,0	42	3,5	36	32	36	349	SWVE22LROMD	SWVE22LRKDSOMD	100
	28	G 1 A	24,0	22,0	39	40	39,5	32,0	30,5	14	66,5	49	3,5	50	46	41		SWVE28LROMD	SWVE28LRKDSOMD	100
	35	G 1 1/4 A	30,0	29,0	49	50	46,5	36,0	35,5	16	76,0	58	3,5	60	55	50		SWVE35LROMD	SWVE35LRKDSOMD	100
	42	G 1 1/2 A	36,0	35,0	55	56	51,5	40,5	40,5	18	86,0	63	3,5	70	60	60		SWVE42LROMD	SWVE42LRKDSOMD	100
S ⁴⁾	06	G 1/4 A	4,0	6,5	18	19	22,0	15,0	13,0	9	27,0	30	3,0	19	19	17	69	SWVE06SROMD	SWVE06SRKDSOMD	160
	08	G 1/4 A	5,0	6,5	18	19	22,0	15,0	13,0	9	27,0	30	3,0	19	19	19	73	SWVE08SROMD	SWVE08SRKDSOMD	160
	10	G 3/8 A	7,0	8,5	22	22	23,5	16,0	15,0	9	32,0	32	3,0	22	22	22	108	SWVE10SROMD	SWVE10SRKDSOMD	100
	12	G 3/8 A	8,0	8,0	22	22	24,5	17,0	18,0	9	37,0	33	3,0	24	24	24	147	SWVE12SROMD	SWVE12SRKDSOMD	100
	14	G 1/2 A	10,0	11,0	26	27	28,0	20,0	18,0	11	37,5	38	4,5	27	27	27	177	SWVE14SROMD	SWVE14SRKDSOMD	100
	16	G 1/2 A	12,0	13,0	26	27	30,0	21,5	21,5	11	44,5	40	4,5	30	27	30	249	SWVE16SROMD	SWVE16SRKDSOMD	100
	20	G 3/4 A	16,0	18,0	32	33	35,0	24,5	24,0	13	49,0	46	3,5	36	32	36	359	SWVE20SROMD	SWVE20SRKDSOMD	100
	25	G 1 A	20,0	22,0	39	40	43,5	31,5	30,5	14	66,5	56	3,5	50	46	46		SWVE25SROMD	SWVE25SRKDSOMD	100
	30	G 1 1/4 A	25,0	29,0	49	50	50,5	37,0	35,5	16	76,0	64	3,5	60	55	50		SWVE30SROMD	SWVE30SRKDSOMD	100
	38	G 1 1/2 A	32,0	35,0	55	56	57,5	41,5	40,5	18	86,0	72	3,5	70	60	60		SWVE38SROMD	SWVE38SRKDSOMD	100

¹⁾ Pressione indicata = Articolo disponibile

²⁾ LL = Serie ultraleggera; ³⁾ L = Serie leggera; ⁴⁾ S = Serie pesante

$$\frac{PN \text{ (bar)}}{10} = PN \text{ (MPa)}$$

Consegna senza dado né anello. Per informazioni sull'ordinazione di raccordi completi o sui materiali di tenuta alternativi vedere pag. 17.

Suffissi codice di ordinazione			
Materiale	Suffisso superficie e materiale	Esempio	Materiale di tenuta standard (non occorre suffisso aggiuntivo)
Acciaio, zincato, esente da CromoVI	CF	SWVE16SROMDCF	NBR
Acciaio, zincato, esente da CromoVI	CF	SWVE16SRKDSOMDCF	NBR

*Aggiungere i suffissi qui di seguito in base al materiale e alla superficie richiesti.

DSVW-M Gomito banjo per basse pressioni

Estremità conica EO 24° / Filettatura maschio metrica

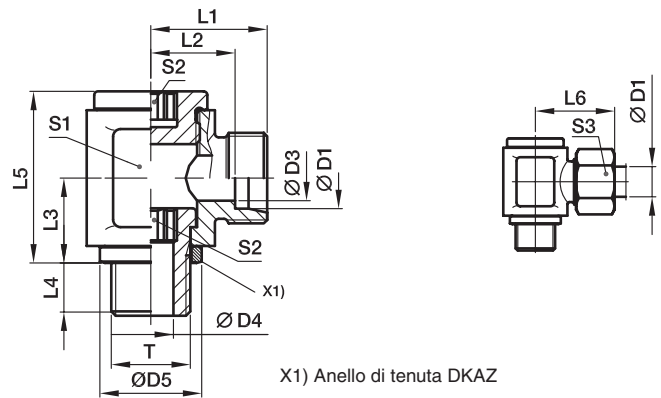

Serie	D1	T	D3	D4	D5	L1	L2	L3	L4	L5	L6	S1	S2	S3	Peso g/1 pezzo	Codice di ordinazione*	PN (bar) ¹⁾ 71
L ³⁾	06	M 10x1,0	4	4,0	14	19,5	12,5	12	8	24	27	18	6	14	51	DSVW06LMOMD	160
	08	M 12x1,5	6	5,5	17	21,5	14,5	15	12	30	29	22	6	17	86	DSVW08LMOMD	160
	10	M 14x1,5	8	7,0	19	22,5	15,5	16	12	30	30	22	8	19	87	DSVW10LMOMD	100
	12	M 16x1,5	10	8,0	21	25,0	18,0	18	12	37	33	27	10	22	145	DSVW12LMOMD	100
	15	M 18x1,5	12	10,0	23	28,0	21,0	20	12	40	36	30	12	27	197	DSVW15LMOMD	100
	18	M 22x1,5	15	14,0	27	29,0	21,5	23	14	46	38	36	14	32	264	DSVW18LMOMD	100
	22	M 26x1,5	19	17,5	31	33,5	26,0	25	16	51	42	41	17	36	379	DSVW22LMOMD	100
	28	M 33x2,0	24	22,0	39	39,0	31,5	32	18	64	48	50	22	41	682	DSVW28LMOMD	100
	35	M 42x2,0	30	27,5	49	46,0	35,5	37	20	76	57	60	27	50	1146	DSVW35LMOMD	63
	42	M 48x2,0	36	32,5	55	51,0	40,0	42	22	85	63	70	32	60	1706	DSVW42LMOMD	63
S ⁴⁾	06	M 12x1,5	4	5,5	17	23,5	16,5	15	12	30	31	22	6	17	90	DSVW06SMOMD	160
	08	M 14x1,5	5	7,0	19	23,5	16,5	16	12	30	31	22	8	19	90	DSVW08SMOMD	160
	10	M 16x1,5	7	8,0	21	26,0	18,5	18	12	37	35	27	10	22	154	DSVW10SMOMD	100
	12	M 18x1,5	8	10,0	23	28,0	20,5	20	12	41	37	30	12	24	199	DSVW12SMOMD	100
	14	M 20x1,5	10	12,0	25	31,0	23,0	21	14	42	41	32	12	27	239	DSVW14SMOMD	100
	16	M 22x1,5	12	14,0	27	31,0	22,5	23	14	46	41	36	14	30	268	DSVW16SMOMD	100
	20	M 27x2,0	16	17,5	32	38,0	27,5	28	16	58	49	46	17	36	532	DSVW20SMOMD	100
	25	M 33x2,0	20	22,0	39	43,0	31,0	32	18	64	55	50	22	46	728	DSVW25SMOMD	100
	30	M 42x2,0	25	27,5	49	50,0	36,5	37	20	76	63	60	27	50	1222	DSVW30SMOMD	63
	38	M 48x2,0	32	32,5	55	56,0	41,0	42	22	85	72	70	32	60	1820	DSVW38SMOMD	63

1) Pressione indicata = Articolo disponibile

3) L = Serie leggera; 4) S = Serie pesante

$$\frac{PN \text{ (bar)}}{10} = PN \text{ (MPa)}$$

Consegna senza dado né anello. Per informazioni sull'ordinazione di raccordi completi vedere pag. 17.

Suffissi codice di ordinazione		
Materiale	Suffisso superficie e materiale	Esempio
Acciaio, zincato, esente da CromoVI	CF	DSVW16SMOMDCF

*Aggiungere i suffissi qui di seguito in base al materiale e alla superficie richiesti.

DSVW-R Gomito banjo per basse pressioni

Estremità conica EO 24° / Filettatura maschio BSPP

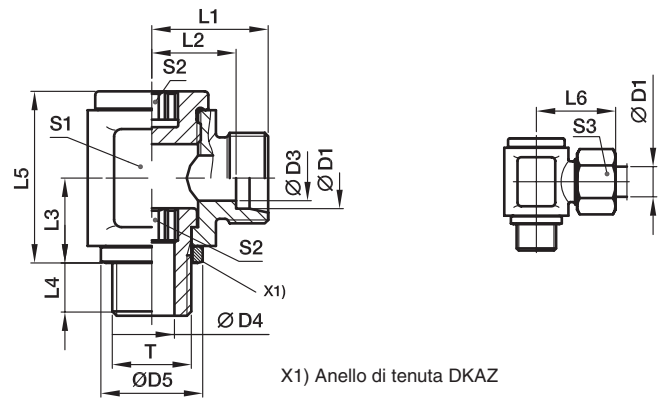

Serie	D1	T	D3	D4	D5	L1	L2	L3	L4	L5	L6	S1	S2	S3	Peso g/1 pezzo	Codice di ordinazione*	PN (bar) ¹⁾ CF
L ³⁾	06	G 1/8 A	4	4,0	14	19,5	12,5	12	8	24	27	18	6	14	51	DSVW06LROMD	160
	08	G 1/4 A	6	6,0	18	21,5	14,5	16	12	30	29	22	8	17	85	DSVW08LROMD	160
	10	G 1/4 A	8	6,0	18	22,5	15,5	16	12	30	30	22	8	19	88	DSVW10LROMD	100
	12	G 3/8 A	10	8,5	22	25,0	18,0	18	12	37	33	27	10	22	147	DSVW12LROMD	100
	15	G 1/2 A	12	12,0	26	29,0	22,0	21	14	42	37	32	12	27	228	DSVW15LROMD	100
	18	G 1/2 A	15	12,0	26	29,0	21,5	23	14	46	38	36	12	32	276	DSVW18LROMD	100
	22	G 3/4 A	19	17,5	32	36,0	28,5	28	16	58	45	46	17	36	516	DSVW22LROMD	100
	28	G 1 A	24	22,0	39	39,0	31,5	32	18	64	48	50	22	41	688	DSVW28LROMD	100
	35	G 1 1/4 A	30	27,5	49	46,0	35,5	37	20	76	57	60	27	50	1147	DSVW35LROMD	63
	42	G 1 1/2 A	36	32,5	55	51,5	40,0	42	22	85	63	70	32	60	1696	DSVW42LROMD	63
S ⁴⁾	06	G 1/4 A	4	6,0	18	23,5	16,5	16	12	30	31	22	8	17	89	DSVW06SROMD	160
	08	G 1/4 A	5	6,0	18	23,5	16,5	16	12	30	31	22	8	19	92	DSVW08SROMD	160
	10	G 3/8 A	7	8,5	22	26,0	18,5	18	12	37	35	27	10	22	150	DSVW10SROMD	100
	12	G 3/8 A	8	8,5	22	26,0	18,5	18	12	37	35	27	10	24	156	DSVW12SROMD	100
	14	G 1/2 A	10	12,0	26	31,0	23,0	21	14	42	41	32	12	27	235	DSVW14SROMD	100
	16	G 1/2 A	12	12,0	26	31,0	22,5	23	14	46	41	36	12	30	275	DSVW16SROMD	100
	20	G 3/4 A	16	17,5	32	38,0	27,5	28	16	58	49	46	17	36	530	DSVW20SROMD	100
	25	G 1 A	20	22,0	39	43,0	31,0	32	18	64	55	50	22	46	734	DSVW25SROMD	100
	30	G 1 1/4 A	25	27,5	49	50,0	36,5	37	20	76	63	60	27	50	1224	DSVW30SROMD	63
	38	G 1 1/2 A	32	32,5	55	57,5	41,0	42	22	85	72	70	32	60	1810	DSVW38SROMD	63

¹⁾ Pressione indicata = Articolo disponibile

³⁾ L = Serie leggera; ⁴⁾ S = Serie pesante

$\frac{PN \text{ (bar)}}{10} = PN \text{ (MPa)}$

Consegna senza dado né anello. Per informazioni sull'ordinazione di raccordi completi vedere pag. 17.

Suffissi codice di ordinazione		
Materiale	Suffisso superficie e materiale	Esempio
Acciaio, zincato, esente da CromoVI	CF	DSVW16SROMDCF

*Aggiungere i suffissi qui di seguito in base al materiale e alla superficie richiesti.

WE-NPT Gomito con terminale maschio

Estremità conica EO 24° / Filettatura maschio NPT (SAEJ476)

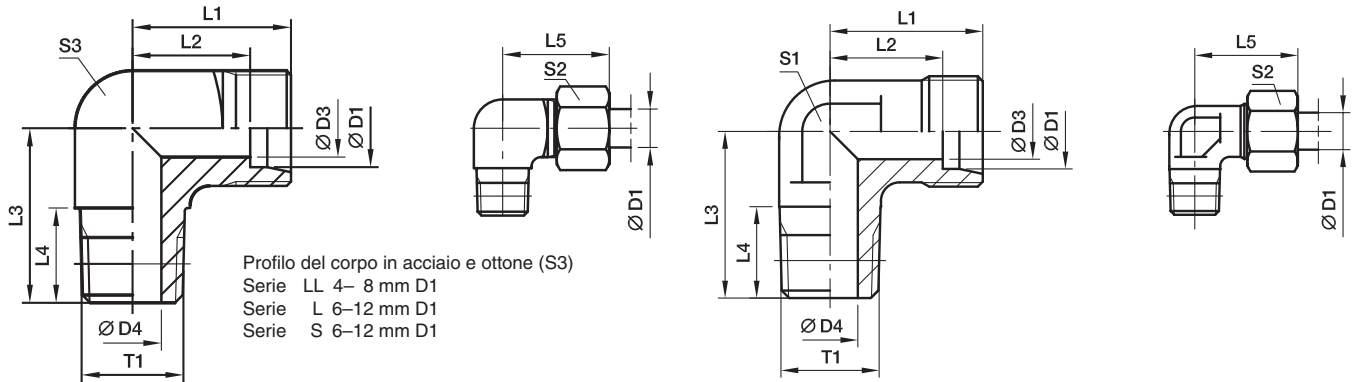

Profilo del corpo in acciaio e ottone (S3)
 Serie LL 4- 8 mm D1
 Serie L 6-12 mm D1
 Serie S 6-12 mm D1

Serie	D1	T1	D3	D4	L1	L2	L3	L4	L5	S1	S2	S3	Peso g/1 pezzo	Codice di ordinazione*	PN (bar) ¹⁾		
															CF	71	MS
LL ²⁾	04	1/8-27 NPT	3,0	4,0	15	11,0	17	10,0	21	9	10	11	18	WE04LL1/8NPT	100		
	06	1/8-27 NPT	4,5	4,5	15	9,5	17	10,0	21	9	12	11	17	WE06LL1/8NPT	100		
	08	1/8-27 NPT	6,0	5,0	17	11,5	20	10,0	23	12	14	12	25	WE08LL1/8NPT	100		
L ³⁾	06	1/8-27 NPT	4,0	4,0	19	12,0	20	10,0	27	12	14	12	29	WE06L1/8NPT	315	315	200
	06	1/4-18 NPT	4,0	7,0	21	14,0	26	14,5	29	12	14	14	44	WE06L1/4NPT	315	315	200
	06	3/8-18 NPT	4,0	8,0	25	18,0	28	14,5	33	17	14	19	55	WE06L3/8NPT	315	315	200
	08	1/8-27 NPT	6,0	4,0	21	14,0	26	10,0	29	12	17	14	48	WE08L1/8NPT	315	315	200
	08	1/4-18 NPT	6,0	6,0	21	14,0	26	14,5	29	12	17	14	47	WE08L1/4NPT	315	315	200
	10	1/4-18 NPT	8,0	7,0	22	15,0	27	14,5	30	14	19	17	61	WE10L1/4NPT	315	315	200
	10	3/8-18 NPT	8,0	8,0	24	17,0	28	14,5	32	17	19	19	92	WE10L3/8NPT	315	315	200
	12	1/4-18 NPT	10,0	7,0	24	17,0	28	14,5	32	17	22	19	82	WE12L1/4NPT	315	315	200
	12	3/8-18 NPT	10,0	8,0	24	17,0	28	14,5	32	17	22	19	92	WE12L3/8NPT	315	315	200
	12	1/2-14 NPT	10,0	11,0	28	21,0	34	19,5	36	19	22		90	WE12L1/2NPT	315	315	200
	15	1/2-14 NPT	12,0	11,0	28	21,0	34	19,5	36	19	27		89	WE15L1/2NPT	315	315	200
	18	1/2-14 NPT	15,0	12,0	31	23,5	36	19,5	40	24	32		150	WE18L1/2NPT	315	315	200
	22	3/4-14 NPT	19,0	16,0	35	27,5	42	19,5	44	27	36		176	WE22L3/4NPT	160	160	100
	28	1-11,5 NPT	24,0	21,0	38	30,5	48	24,5	47	36	41		314	WE28L1NPT	160	160	100
	35	1 1/4-11,5 NPT	30,0	28,0	45	34,5	54	25,0	56	41	50		465	WE35L11/4NPT	160	160	100
42	1 1/2-11,5 NPT	36,0	34,0	51	40,0	61	26,0	63	50	60		849	WE42L11/2NPT	160	160	100	
S ⁴⁾	06	1/4-18 NPT	4,0	4,0	23	16,0	26	14,5	31	12	17	14	56	WE06S1/4NPT	630	630	400
	08	1/4-18 NPT	5,0	5,0	24	17,0	27	14,5	32	14	19	17	73	WE08S1/4NPT	630	630	400
	08	3/8-18 NPT	5,0	8,0	25	18,0	28	14,5	33	17	19	19	77	WE08S3/8NPT	630	630	400
	08	1/2-14 NPT	5,0	10,0	30	23,0	34	19,5	38	19	19		75	WE08S1/2NPT	630	630	400
	10	1/4-18 NPT	7,0	5,0	25	17,5	28	14,5	34	17	22	19	96	WE10S1/4NPT	630	630	400
	10	3/8-18 NPT	7,0	7,0	25	17,5	28	14,5	34	17	22	19	98	WE10S3/8NPT	630	630	400
	12	1/4-18 NPT	8,0	5,0	29	21,5	29	14,5	38	17	24	22	73	WE12S1/4NPT	630	630	400
	12	3/8-18 NPT	8,0	8,0	29	22,5	28	14,5	38	17	24	22	123	WE12S3/8NPT	630	630	400
	12	1/2-14 NPT	8,0	10,0	30	22,5	34	19,5	39	19	24		107	WE12S1/2NPT	630	630	400
	14	1/2-14 NPT	10,0	10,0	30	22,0	34	19,5	40	19	27		103	WE14S1/2NPT	630	630	400
	16	1/2-14 NPT	12,0	12,0	33	24,5	36	19,5	43	24	30		157	WE16S1/2NPT	400	400	250
	20	3/4-14 NPT	16,0	16,0	37	26,5	42	19,5	48	27	36		205	WE20S3/4NPT	400	400	250
	25	1-11,5 NPT	20,0	20,0	42	30,0	48	24,5	54	36	46		381	WE25S1NPT	400	400	250
	30	1 1/4-11,5 NPT	25,0	25,0	49	35,5	54	25,0	62	41	50		598	WE30S11/4NPT	400	400	250
	38	1 1/2-11,5 NPT	32,0	32,0	57	41,0	61	26,0	72	50	60		1029	WE38S11/2NPT	315	315	200

1) Pressione indicata = Articolo disponibile

2) LL = Serie ultraleggera; 3) L = Serie leggera;

4) S = Serie pesante

$$\frac{PN \text{ (bar)}}{10} = PN \text{ (MPa)}$$

Consegna senza dado né anello. Per informazioni sull'ordinazione di raccordi completi vedere pag. 17.

*Aggiungere i suffissi qui di seguito in base al materiale e alla superficie richiesti.

Suffissi codice di ordinazione		
Materiale	Suffisso superficie e materiale	Esempio
Acciaio, zincato, esente da CromoVI	CFX	WE16S1/2NPTCFX
Acciaio inossidabile	71X	WE16S1/2NPT71X
Ottone	MSX	WE16S1/2NPTMSX

WE-M(KEG) Gomito con terminale maschio

Estremità conica EO 24° / Filettatura maschio metrica conica (DIN 3852-1, tipo C)

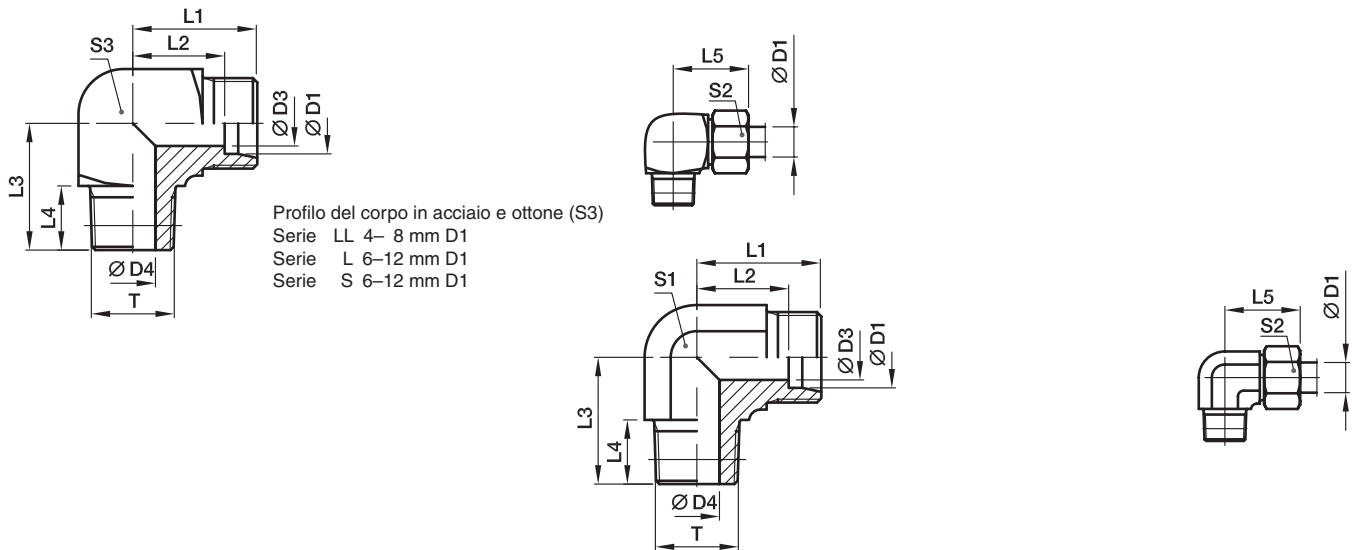

Serie	D1	T	D3	D4	L1	L2	L3	L4	L5	S1	S2	S3	Peso g/1 pezzo	Codice di ordinazione*	PN (bar) ¹⁾		
															CF	71	MS
LL ²⁾	04	M 08×1,0 keg.	3,0	3,5	15	11,0	17	8	21	9	10	9	14	WE04LLM	100	100	63
	06	M 10×1,0 keg.	4,5	4,5	15	9,5	17	8	21	9	12	11	17	WE06LLM	100	100	63
	08	M 10×1,0 keg.	6,0	6,0	17	11,5	20	8	23	12	14	12	25	WE08LLM	100	100	63
L ³⁾	06	M 10×1,0 keg.	4,0	4,0	19	12,0	20	8	27	12	14	12	29	WE06LM	315	315	200
	08	M 12×1,5 keg.	6,0	6,0	21	14,0	26	12	29	12	17	14	46	WE08LM	315	315	200
	10	M 14×1,5 keg.	8,0	7,0	22	15,0	27	12	30	14	19	17	62	WE10LM	315	315	200
	12	M 16×1,5 keg.	10,0	9,0	24	17,0	28	12	32	17	22	19	89	WE12LM	315	315	200
	15	M 18×1,5 keg.	12,0	11,0	28	21,0	32	12	36	19	27		78	WE15LM	315	315	200
	18	M 22×1,5 keg.	15,0	14,0	31	23,0	36	14	40	24	32		148	WE18LM	315	315	200
S ⁴⁾	06	M 12×1,5 keg.	4,0	4,0	23	16,0	26	12	31	12	17	14	53	WE06SM	400	400	250
	08	M 14×1,5 keg.	5,0	5,0	24	17,0	27	12	32	14	19	17	78	WE08SM	400	400	250
	10	M 16×1,5 keg.	7,0	7,0	25	17,5	28	12	34	17	22	19	102	WE10SM	400	400	250
	12	M 18×1,5 keg.	8,0	8,0	29	21,5	28	12	38	17	24	22	134	WE12SM	400	400	250
	14	M 20×1,5 keg.	10,0	10,0	30	22,0	32	14	40	19	27		99	WE14SM	400	400	
	16	M 22×1,5 keg.	12,0	12,0	33	24,5	32	14	43	24	30		161	WE16SM	400	400	250

¹⁾ Pressione indicata = Articolo disponibile

²⁾ LL = Serie ultraleggera; ³⁾ L = Serie leggera; ⁴⁾ S = Serie pesante

$\frac{PN \text{ (bar)}}{10} = PN \text{ (MPa)}$

Consegna senza dado né anello. Per informazioni sull'ordinazione di raccordi completi vedere pag. 17.

*Aggiungere i **suffissi** qui di seguito in base al materiale e alla superficie richiesti.

Suffissi codice di ordinazione		
Materiale	Suffisso superficie e materiale	Esempio
Acciaio, zincato, esente da CromoVI	CFX	WE16SMCFX
Acciaio inossidabile	71X	WE16SM71X
Ottone	MSX	WE16SMMSX

WE-M Gomito con terminale maschio

Estremità conica EO 24° / Filettatura maschio metrica – bordo di tenuta metallico (ISO 9974)

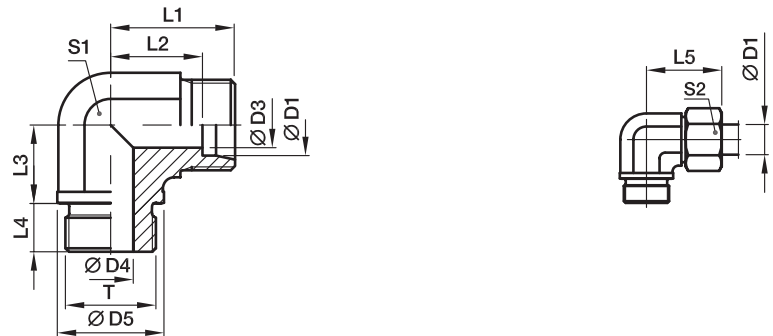

Serie	D1	T	D3	D4	D5	L1	L2	L3	L4	L5	S1	S2	Peso g/1 pezzo	Codice di ordinazione*	PN (bar) ¹⁾	
															CF	71
L ³⁾	22	M 26x1,5	19	18	31	35	27,5	26	16	44	27	36	173	WE22LM	160	160
	28	M 33x2,0	24	23	39	38	30,5	30	18	47	36	41	303	WE28LM	160	160
	35	M 42x2,0	30	30	49	45	34,5	34	20	56	41	50	469	WE35LM	160	160
	42	M 48x2,0	36	36	55	51	40,0	39	22	63	50	60	661	WE42LM	160	160
S ⁴⁾	20	M 27x2,0	16	16	32	37	26,5	26	16	48	27	36	208	WE20SM	400	400
	25	M 33x2,0	20	20	39	42	30,0	30	18	54	36	46	396	WE25SM	250	250
	30	M 42x2,0	25	25	49	49	35,5	34	20	62	41	50	632	WE30SM	160	160
	38	M 48x2,0	32	32	55	57	41,0	39	22	72	50	60	907	WE38SM	160	160

¹⁾ Pressione indicata = Articolo disponibile

³⁾ L = Serie leggera; ⁴⁾ S = Serie pesante

$$\frac{\text{PN (bar)}}{10} = \text{PN (MPa)}$$

Consegna senza dado né anello. Per informazioni sull'ordinazione di raccordi completi vedere pag. 17.

Suffissi codice di ordinazione		
Materiale	Suffisso superficie e materiale	Esempio
Acciaio, zincato, esente da CromoVI	CFX	WE20SMCFX
Acciaio inossidabile	71X	WE20SM71X

*Aggiungere i **suffissi** qui di seguito in base al materiale e alla superficie richiesti.

WE-R Gomito con terminale maschio

Estremità conica EO 24° / Filettatura maschio BSPP – bordo di tenuta metallico (ISO 1179)

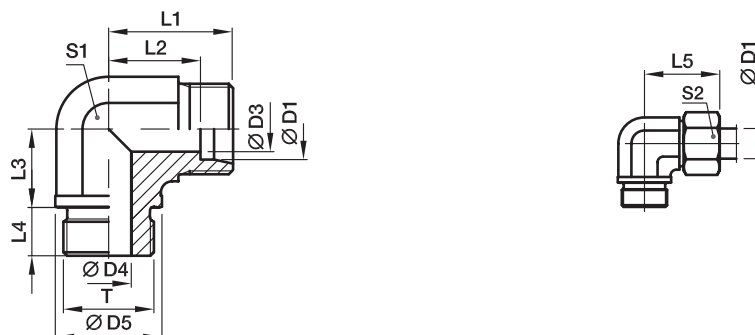

Serie	D1	T	D3	D4	D5	L1	L2	L3	L4	L5	S1	S2	Peso g/1 pezzo	Codice di ordinazione*	PN (bar) ¹⁾		
															CF	71	MS
L ³⁾	22	G 3/4 A	19	18	32	35	27,5	26	16	44	27	36	168	WE22LR	160	160	100
	28	G 1 A	24	23	39	38	30,5	30	18	47	36	41	305	WE28LR	160	160	100
	35	G 1 1/4 A	30	30	49	45	34,5	34	20	56	41	50	465	WE35LR	160	160	100
	42	G 1 1/2 A	36	36	55	51	40,0	39	22	63	50	60	706	WE42LR	160	160	100
S ⁴⁾	20	G 3/4 A	16	16	32	37	26,5	26	16	48	27	36	210	WE20SR	400	400	250
	25	G 1 A	20	20	39	42	30,0	30	18	54	36	46	388	WE25SR	250	250	160
	30	G 1 1/4 A	25	25	49	49	35,5	34	20	62	41	50	630	WE30SR	160	160	100
	38	G 1 1/2 A	32	32	55	57	41,0	39	22	72	50	60	888	WE38SR	160	160	100

¹⁾ Pressione indicata = Articolo disponibile

³⁾ L = Serie leggera; ⁴⁾ S = Serie pesante

$\frac{PN \text{ (bar)}}{10} = PN \text{ (MPa)}$

Consegna senza dado né anello. Per informazioni sull'ordinazione di raccordi completi vedere pag. 17.

Suffissi codice di ordinazione		
Materiale	Suffisso superficie e materiale	Esempio
Acciaio, zincato, esente da CromoVI	CFX	WE20SRCFX
Acciaio inossidabile	71X	WE20SR71X
Ottone	MSX	WE20SRMSX

*Aggiungere i **suffissi** qui di seguito in base al materiale e alla superficie richiesti.

WE-R (KEG) Gomito con terminale maschio

Estremità conica EO 24° / Filettatura maschio BSP conica corta (DIN 3852-2, tipo C)

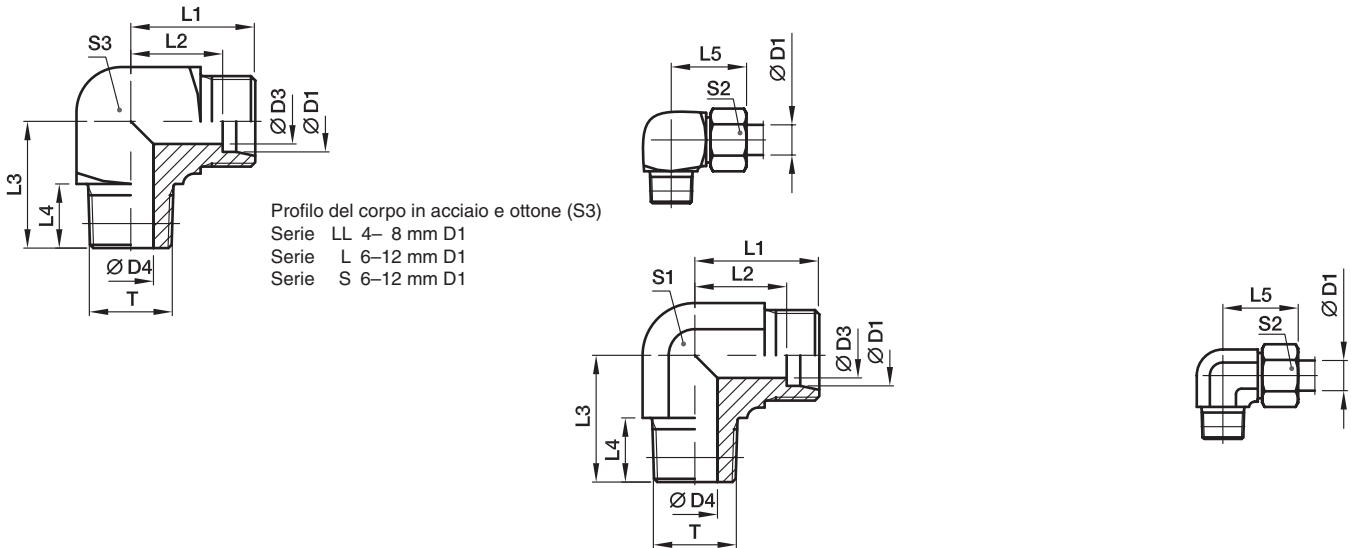

Serie	D1	T	D3	D4	L1	L2	L3	L4	L5	S1	S2	S3	Peso g/1 pezzo	Codice di ordinazione*	PN (bar) ¹⁾		
															CF	71	MS
LL ²⁾	04	R 1/8 keg.	3,0	4,0	15	11,0	17	8	21	9	10	11	17	WE04LLR	100	100	63
	06	R 1/8 keg.	4,5	4,5	15	9,5	17	8	21	9	12	11	17	WE06LLR	100	100	63
	08	R 1/8 keg.	6,0	6,0	17	11,5	20	8	23	12	14	12	24	WE08LLR	100	100	63
	10	R 1/4 keg.	8,0	7,0	18	12,5	23	12	24	12	17	14	36	WE10LLR	100		
	12	R 1/4 keg.	10,0	7,0	19	13,0	23	12	25	14	19	17	46	WE12LLR	100		
L ³⁾	06	R 1/8 keg.	4,0	4,0	19	12,0	20	8	27	12	14	12	30	WE06LR	315	315	200
	06	R 1/4 keg.	4,0	6,0	21	14,0	26	12	29	12	14	14	47	WE06LR1/4	315	315	
	08	R 1/4 keg.	6,0	6,0	21	14,0	26	12	29	12	17	14	46	WE08LR	315	315	200
	08	R 1/8 keg.	6,0	4,0	21	14,0	26	8	29	12	17	14	49	WE08LR1/8	315	315	
	08	R 3/8 keg.	6,0	9,0	24	17,0	28	12	32	17	17	19	94	WE08LR3/8	315	315	
	10	R 1/4 keg.	8,0	7,0	22	15,0	27	12	30	14	19	17	61	WE10LR	315	315	200
	10	R 3/8 keg.	8,0	9,0	24	17,0	28	12	32	17	19	19	87	WE10LR3/8	315	315	
	12	R 3/8 keg.	10,0	9,0	24	17,0	28	12	32	17	22	19	88	WE12LR	315	315	200
	12	R 1/4 keg.	10,0	7,0	24	17,0	27	12	32	17	22	19	80	WE12LR1/4	315	315	
	12	R 1/2 keg.	10,0	11,0	28	21,0	34	14	36	19	22		89	WE12LR1/2	315	315	
	15	R 1/2 keg.	12,0	11,0	28	21,0	34	14	36	19	27		94	WE15LR	315	315	200
	18	R 1/2 keg.	15,0	14,0	31	23,5	36	14	40	24	32		141	WE18LR	315	315	200
S ⁴⁾	06	R 1/4 keg.	4,0	4,0	23	16,0	26	12	31	12	17	14	56	WE06SR	400	400	250
	06	R 3/8 keg.	4,0	7,0	25	18,0	28	12	33	17	17	19	61	WE06SR3/8	400	400	
	08	R 1/4 keg.	5,0	5,0	24	17,0	27	12	32	14	19	17	73	WE08SR	400	400	250
	08	R 3/8 keg.	5,0	7,0	25	18,0	28	12	33	17	19	19	63	WE08SR3/8	400	400	
	10	R 3/8 keg.	7,0	7,0	25	17,5	28	12	34	17	22	19	104	WE10SR	400	400	250
	10	R 1/4 keg.	7,0	5,0	25	17,5	28	12	34	17	22	19	59	WE10SR1/4	400	400	
	10	R 1/2 keg.	7,0	10,0	30	22,5	32	14	39	19	22		98	WE10SR1/2	400	400	
	12	R 3/8 keg.	8,0	8,0	29	21,5	28	12	38	17	24	22	126	WE12SR	400	400	250
	12	R 1/2 keg.	8,0	11,0	30	22,5	32	14	39	19	24		97	WE12SR1/2	400	400	
	14	R 1/2 keg.	10,0	10,0	30	22,0	32	14	40	19	27		101	WE14SR	400	400	250
	16	R 1/2 keg.	12,0	12,0	33	24,5	32	14	43	24	30		150	WE16SR	400	400	250

1) Pressione indicata = Articolo disponibile

2) LL = Serie ultraleggera; 3) L = Serie leggera;

4) S = Serie pesante

$$\frac{PN \text{ (bar)}}{10} = PN \text{ (MPa)}$$

Consegna senza dado né anello. Per informazioni sull'ordinazione di raccordi completi vedere pag. 17.

*Aggiungere i suffissi qui di seguito in base al materiale e alla superficie richiesti.

Suffissi codice di ordinazione		
Materiale	Suffisso superficie e materiale	Esempio
Acciaio, zincato, esente da CromoVI	CFX	WE16SRCFX
Acciaio inossidabile	71X	WE16SR71X
Ottone	MSX	WE16SRMSX

TE-M T di linea con terminale maschio

Estremità conica EO 24° / Filettatura maschio metrica – bordo di tenuta metallico (ISO 9974)

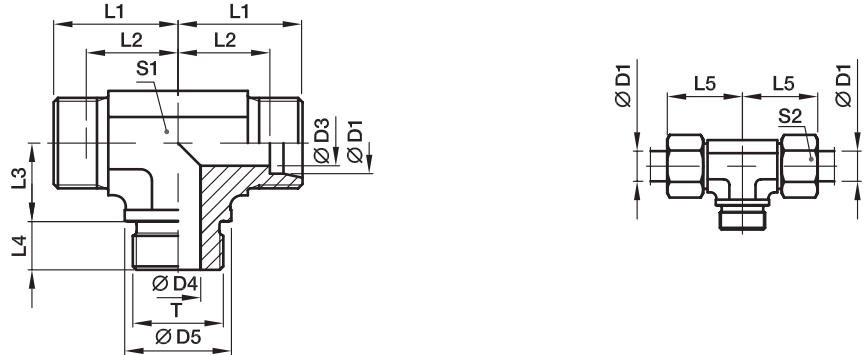

Serie	D1	T	D3	D4	D5	L1	L2	L3	L4	L5	S1	S2	Peso g/1 pezzo	Codice di ordinazione*	PN (bar) ¹⁾	
															CF	71
L ³⁾	22	M 26x1,5	19	18	31	35	27,5	26	16	44	27	36	208	TE22LM	160	160
	28	M 33x2,0	24	23	39	38	30,5	30	18	47	36	41	352	TE28LM	160	160
	35	M 42x2,0	30	30	49	45	34,5	34	20	56	41	50	554	TE35LM	160	160
	42	M 48x2,0	36	36	55	51	40,0	39	22	63	50	60	847	TE42LM	160	160
S ⁴⁾	20	M 27x2,0	16	16	32	37	26,5	26	16	48	27	36	265	TE20SM	400	400
	25	M 33x2,0	20	20	39	42	30,0	30	18	54	36	46	482	TE25SM	250	250
	30	M 42x2,0	25	25	49	49	35,5	34	20	62	41	50	772	TE30SM	160	160
	38	M 48x2,0	32	32	55	57	41,0	39	22	72	50	60	1121	TE38SM	160	160

¹⁾ Pressione indicata = Articolo disponibile

³⁾ L = Serie leggera; ⁴⁾ S = Serie pesante

 $\frac{PN \text{ (bar)}}{10} = PN \text{ (MPa)}$
Consegna senza dado né anello. Per informazioni sull'ordinazione di raccordi completi vedere pag. I7.

 *Aggiungere i **suffissi** qui di seguito in base al materiale e alla superficie richiesti.

Suffissi codice di ordinazione		
Materiale	Suffisso superficie e materiale	Esempio
Acciaio, zincato, esente da CromoVI	CFX	TE20SMCFX
Acciaio inossidabile	71X	TE20SM71X

TE-R T di linea con terminale maschio

Estremità conica EO 24° / Filettatura maschio BSPP – bordo di tenuta metallico (ISO 1179)

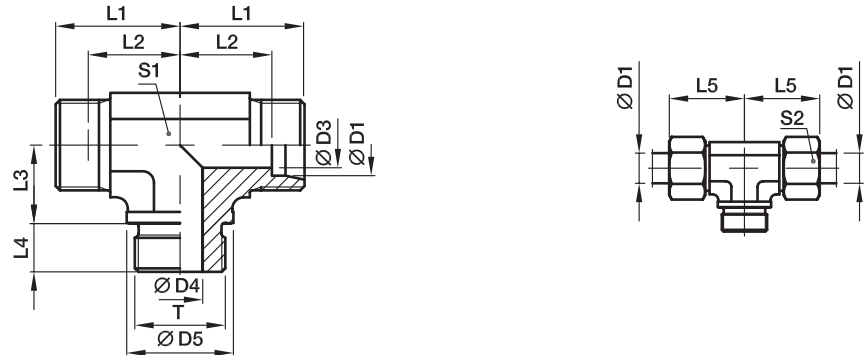

Serie	D1	T	D3	D4	D5	L1	L2	L3	L4	L5	S1	S2	Peso g/1 pezzo	Codice di ordinazione*	PN (bar) ¹⁾		
															CF	71	MS
L ³⁾	22	G 3/4 A	19	18	32	35	27,5	26	16	44	27	36	208	TE22LR	160	160	100
	28	G 1 A	24	23	39	38	30,5	30	18	47	36	41	378	TE28LR	160	160	100
	35	G 1 1/4 A	30	30	49	45	34,5	34	20	56	41	50	554	TE35LR	160	160	100
	42	G 1 1/2 A	36	36	55	51	40,0	39	22	63	50	60	847	TE42LR	160	160	100
S ⁴⁾	20	G 3/4 A	16	16	32	37	26,5	26	16	48	27	36	267	TE20SR	400	400	250
	25	G 1 A	20	20	39	42	30,0	30	18	54	36	46	485	TE25SR	250	250	
	30	G 1 1/4 A	25	25	49	49	35,5	34	20	62	41	50	762	TE30SR	160	160	
	38	G 1 1/2 A	32	32	55	57	41,0	39	22	72	50	60	1121	TE38SR	160	160	

¹⁾ Pressione indicata = Articolo disponibile

³⁾ L = Serie leggera; ⁴⁾ S = Serie pesante

$\frac{PN \text{ (bar)}}{10} = PN \text{ (MPa)}$

Consegna senza dado né anello. Per informazioni sull'ordinazione di raccordi completi vedere pag. I7.

*Aggiungere i **suffissi** qui di seguito in base al materiale e alla superficie richiesti.

Suffissi codice di ordinazione		
Materiale	Suffisso superficie e materiale	Esempio
Acciaio, zincato, esente da CromoVI	CFX	TE20SRCFX
Acciaio inossidabile	71X	TE20SR71X
Ottone	MSX	TE20SRMSX

TE-R (KEG) T di linea con terminale maschio

Estremità conica EO 24° / Filettatura maschio BSP conica corta (DIN 3852-2, tipo C)

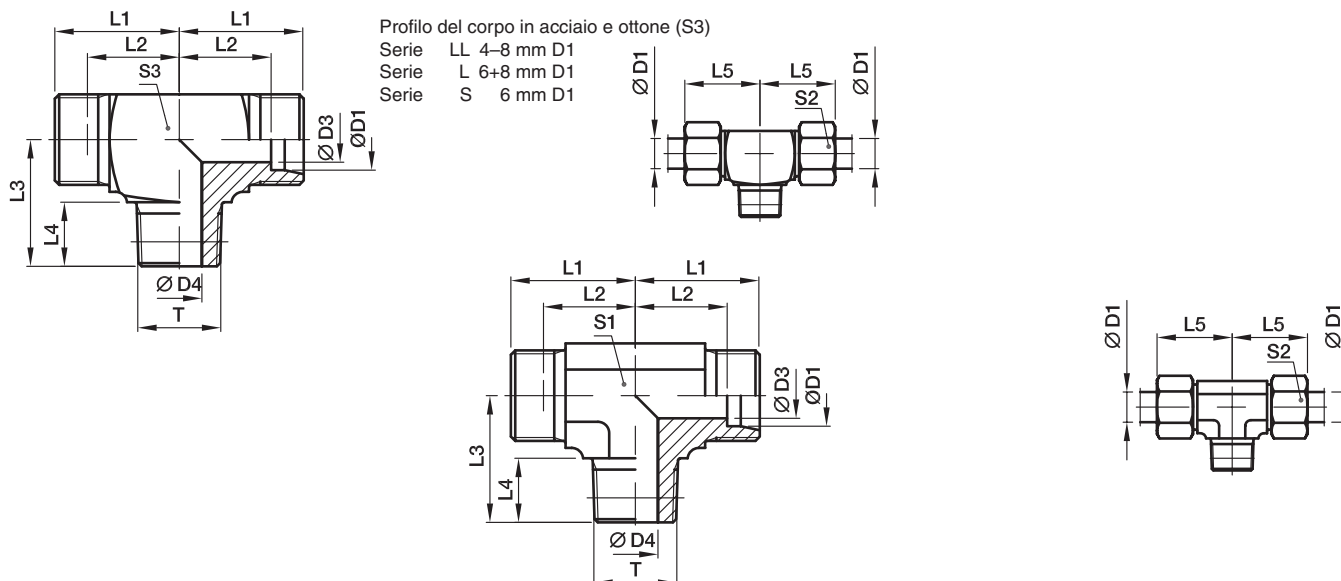

Serie	D1	T	D3	D4	L1	L2	L3	L4	L5	S1	S2	S3	Peso g/1 pezzo	Codice di ordinazione*	PN (bar) ¹⁾		
															CF	71	MS
LL ²⁾	04	R 1/8 keg.	3,0	4,0	15	11,0	17	8	21	9	10	11	21	TE04LLR	100	100	63
	06	R 1/8 keg.	4,5	4,5	15	9,5	17	8	21	9	12	11	21	TE06LLR	100	100	63
	08	R 1/8 keg.	6,0	6,0	17	11,5	20	8	23	12	14	12	29	TE08LLR	100	100	63
L ³⁾	06	R 1/8 keg.	4,0	4,0	19	12,0	20	8	27	12	14	12	38	TE06LR	315	315	200
	08	R 1/4 keg.	6,0	6,0	21	14,0	26	12	29	12	17	14	58	TE08LR	315	315	200
	10	R 1/4 keg.	8,0	7,0	22	15,0	27	12	30	14	19		43	TE10LR	315	315	200
	12	R 3/8 keg.	10,0	9,0	24	17,0	28	12	32	17	22		61	TE12LR	315	315	200
	15	R 1/2 keg.	12,0	11,0	28	21,0	34	14	36	19	27		113	TE15LR	315	315	200
	18	R 1/2 keg.	15,0	14,0	31	23,5	36	14	40	24	32		149	TE18LR	315	315	200
S ⁴⁾	06	R 1/4 keg.	4,0	4,0	23	16,0	26	12	31	12	17	14	73	TE06SR	400	400	250
	08	R 1/4 keg.	5,0	5,0	24	17,0	27	12	32	14	19		61	TE08SR	400	400	250
	10	R 3/8 keg.	7,0	7,0	25	17,5	28	12	34	17	22		82	TE10SR	400	400	250
	12	R 3/8 keg.	8,0	8,0	29	21,5	28	12	38	17	24		105	TE12SR	400	400	250
	14	R 1/2 keg.	10,0	10,0	30	22,0	32	14	40	19	27		134	TE14SR	400	400	250
	16	R 1/2 keg.	12,0	12,0	33	24,5	32	14	43	24	30		175	TE16SR	400	400	250

¹⁾ Pressione indicata = Articolo disponibile

²⁾ LL = Serie ultraleggera; ³⁾ L = Serie leggera; ⁴⁾ S = Serie pesante

$$\frac{\text{PN (bar)}}{10} = \text{PN (MPa)}$$

Consegna senza dado né anello. Per informazioni sull'ordinazione di raccordi completi vedere pag. 17.

*Aggiungere i suffissi qui di seguito in base al materiale e alla superficie richiesti.

Suffissi codice di ordinazione		
Materiale	Suffisso superficie e materiale	Esempio
Acciaio, zincato, esente da CromoVI	CFX	TE16SRCFX
Acciaio inossidabile	71X	TE16SR71X
Ottone	MSX	TE16SRMSX

TE-M(KEG) T di linea con terminale maschio

Estremità conica EO 24° / Filettatura maschio metrica conica corta (DIN 3852-1, tipo C)

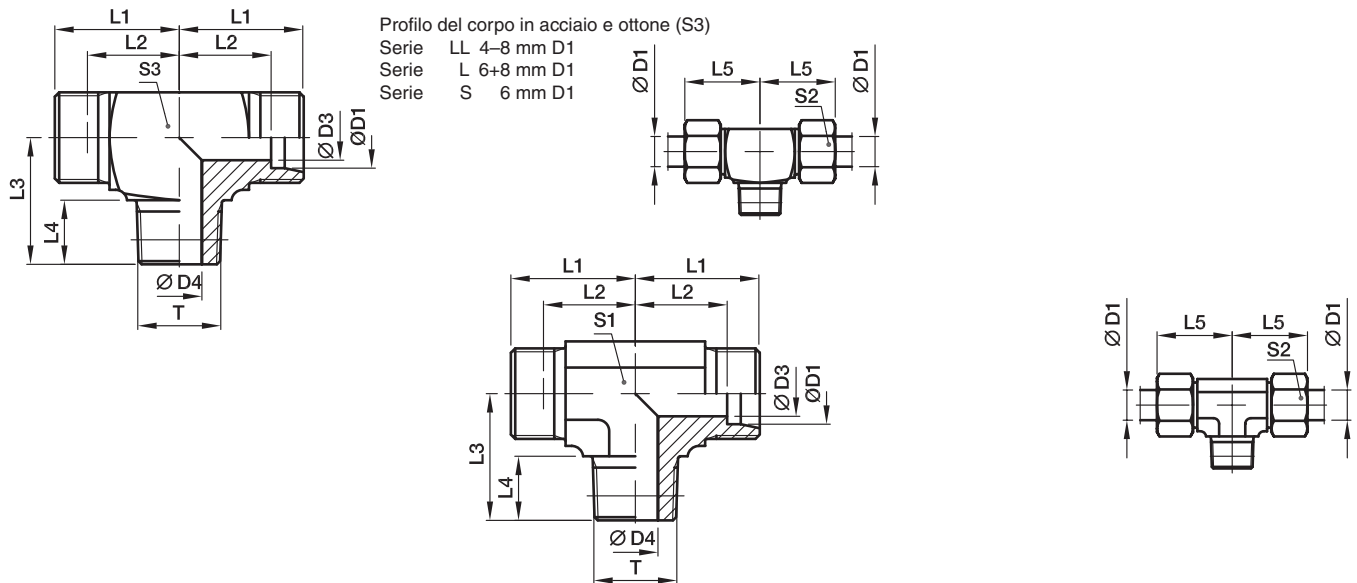

Serie	D1	T	D3	D4	L1	L2	L3	L4	L5	S1	S2	S3	Peso g/1 pezzo	Codice di ordinazione*	PN (bar) ¹⁾	
															CF	71
LL ²⁾	04	M 08x1.0 keg.	3,0	3,5	15	11,0	17	8	21	9	10	9	17	TE04LLM	100	100
	06	M 10x1.0 keg.	4,5	4,5	15	9,5	17	8	21	9	12	11	20	TE06LLM	100	100
	08	M 10x1.0 keg.	6,0	6,0	17	11,5	20	8	23	12	14	12	29	TE08LLM	100	100
L ³⁾	06	M 10x1.0 keg.	4,0	4,0	19	12,0	20	8	27	12	14	12	38	TE06LM	315	315
	08	M 12x1.5 keg.	6,0	6,0	21	14,0	26	12	29	12	17	14	54	TE08LM	315	315
	10	M 14x1.5 keg.	8,0	7,0	22	15,0	27	12	30	14	19		45	TE10LM	315	315
	12	M 16x1.5 keg.	10,0	9,0	24	17,0	28	12	32	17	22		60	TE12LM	315	315
	15	M 18x1.5 keg.	12,0	11,0	28	21,0	32	12	36	19	27		100	TE15LM	315	315
	18	M 22x1.5 keg.	15,0	14,0	31	23,5	36	14	40	24	32		149	TE18LM	315	315
S ⁴⁾	06	M 12x1.5 keg.	4,0	4,0	23	16,0	26	12	31	12	17	14	69	TE06SM	400	400
	08	M 14x1.5 keg.	5,0	5,0	24	17,0	27	12	32	14	19		98	TE08SM	400	400
	10	M 16x1.5 keg.	7,0	7,0	25	17,5	28	12	34	17	22		82	TE10SM	400	400
	12	M 18x1.5 keg.	8,0	8,0	29	21,5	28	12	38	17	24		106	TE12SM	400	400
	14	M 20x1.5 keg.	10,0	10,0	30	22,0	32	14	40	19	27		126	TE14SM	400	400
	16	M 22x1.5 keg.	12,0	12,0	33	24,5	32	14	43	24	30		177	TE16SM	400	400

¹⁾ Pressione indicata = Articolo disponibile

²⁾ LL = Serie ultraleggera; ³⁾ L = Serie leggera; ⁴⁾ S = Serie pesante

$$\frac{PN \text{ (bar)}}{10} = PN \text{ (MPa)}$$

Consegna senza dado né anello. Per informazioni sull'ordinazione di raccordi completi vedere pag. 17.

*Aggiungere i suffissi qui di seguito in base al materiale e alla superficie richiesti.

Suffissi codice di ordinazione		
Materiale	Suffisso superficie e materiale	Esempio
Acciaio, zincato, esente da CromoVI	CFX	TE16SMCFX
Acciaio inossidabile	71X	TE16SM71X

LE-M T di derivazione con terminale maschio

Estremità conica EO 24° / Filettatura maschio metrica – bordo di tenuta metallico (ISO 9974)

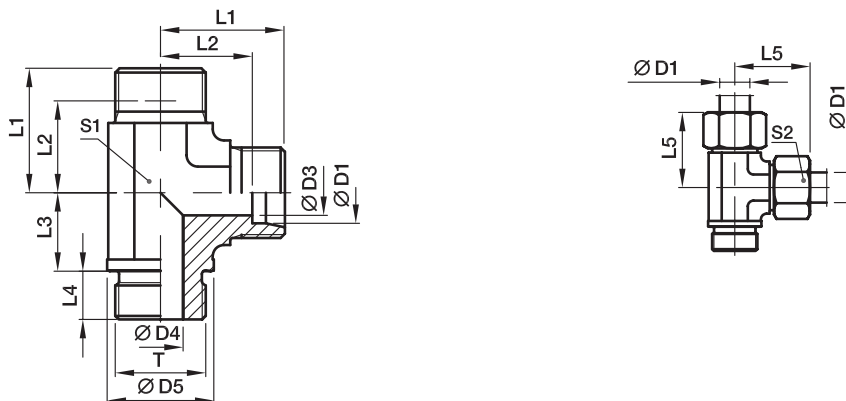

Serie	D1	T	D3	D4	D5	L1	L2	L3	L4	L5	S1	S2	Peso g/1 pezzo	Codice di ordinazione*	PN (bar) ¹⁾	
															CF	71
L ³⁾	22	M 26×1,5	19	18	31	35	27,5	26	16	44	27	36	225	LE22LM	160	160
	28	M 33×2,0	24	23	39	38	30,5	30	18	47	36	41	382	LE28LM	160	160
	35	M 42×2,0	30	30	49	45	34,5	34	20	56	41	50	583	LE35LM	160	160
	42	M 48×2,0	36	36	55	51	40,0	39	22	63	50	60	821	LE42LM	160	160
S ⁴⁾	20	M 27×2,0	16	16	32	37	26,5	26	16	48	27	36	264	LE20SM	400	400
	25	M 33×2,0	20	20	39	42	30,0	30	18	54	36	46	497	LE25SM	250	250
	30	M 42×2,0	25	25	49	49	35,5	34	20	62	41	50	744	LE30SM	160	160
	38	M 48×2,0	32	32	55	57	41,0	39	22	72	50	60	1111	LE38SM	160	160

¹⁾ Pressione indicata = Articolo disponibile

³⁾ L = Serie leggera; ⁴⁾ S = Serie pesante

$\frac{PN (bar)}{10} = PN (MPa)$

Consegna senza dado né anello. Per informazioni sull'ordinazione di raccordi completi vedere pag. I7.

*Aggiungere i **suffissi** qui di seguito in base al materiale e alla superficie richiesti.

Suffissi codice di ordinazione		
Materiale	Suffisso superficie e materiale	Esempio
Acciaio, zincato, esente da CromoVI	CFX	LE20SMCFX
Acciaio inossidabile	71X	LE20SM71X

LE-R T di derivazione con terminale maschio

Estremità conica EO 24° / Filettatura maschio BSPP – bordo di tenuta metallico (ISO 1179)

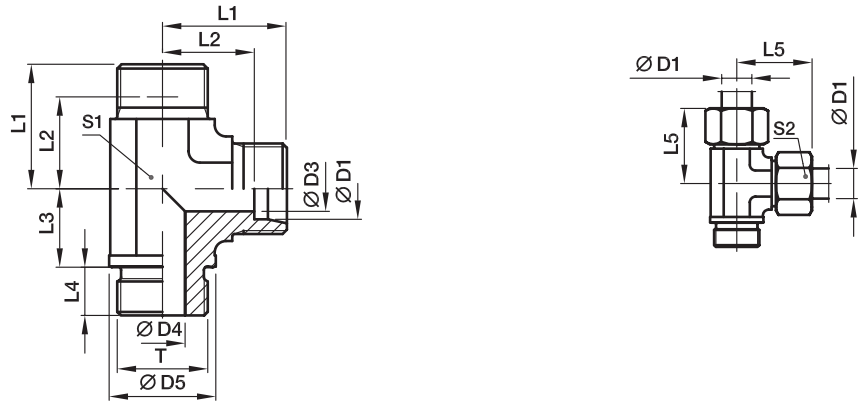

Serie	D1	T	D3	D4	D5	L1	L2	L3	L4	L5	S1	S2	Peso g/1 pezzo	Codice di ordinazione*	PN (bar) ¹⁾	
															CF	71
L ³⁾	22	G 3/4 A	19	18	32	35	27,5	26	16	44	27	36	225	LE22LR	160	160
	28	G 1 A	24	23	39	38	30,5	30	18	47	36	41	358	LE28LR	160	160
	35	G 1 1/4 A	30	30	49	45	34,5	34	20	56	41	50	583	LE35LR	160	160
	42	G 1 1/2 A	36	36	55	51	40,0	39	22	63	50	60	821	LE42LR	160	160
S ⁴⁾	20	G 3/4 A	16	16	32	37	26,5	26	16	48	27	36	259	LE20SR	400	400
	25	G 1 A	20	20	39	42	30,0	30	18	54	36	46	495	LE25SR	250	250
	30	G 1 1/4 A	25	25	49	49	35,5	34	20	62	41	50	744	LE30SR	160	160
	38	G 1 1/2 A	32	32	55	57	41,0	39	22	72	50	60	1111	LE38SR	160	160

¹⁾ Pressione indicata = Articolo disponibile

³⁾ L = Serie leggera; ⁴⁾ S = Serie pesante

$\frac{PN (bar)}{10} = PN (MPa)$

Consegna senza dado né anello. Per informazioni sull'ordinazione di raccordi completi vedere pag. I7.

*Aggiungere i **suffissi** qui di seguito in base al materiale e alla superficie richiesti.

Suffissi codice di ordinazione		
Materiale	Suffisso superficie e materiale	Esempio
Acciaio, zincato, esente da CromoVI	CFX	LE20SRCFX
Acciaio inossidabile	71X	LE20SR71X

LE-R (KEG) T di derivazione con terminale maschio

Estremità conica EO 24° / Filettatura maschio BSP conica corta (DIN 3852-2, tipo C)

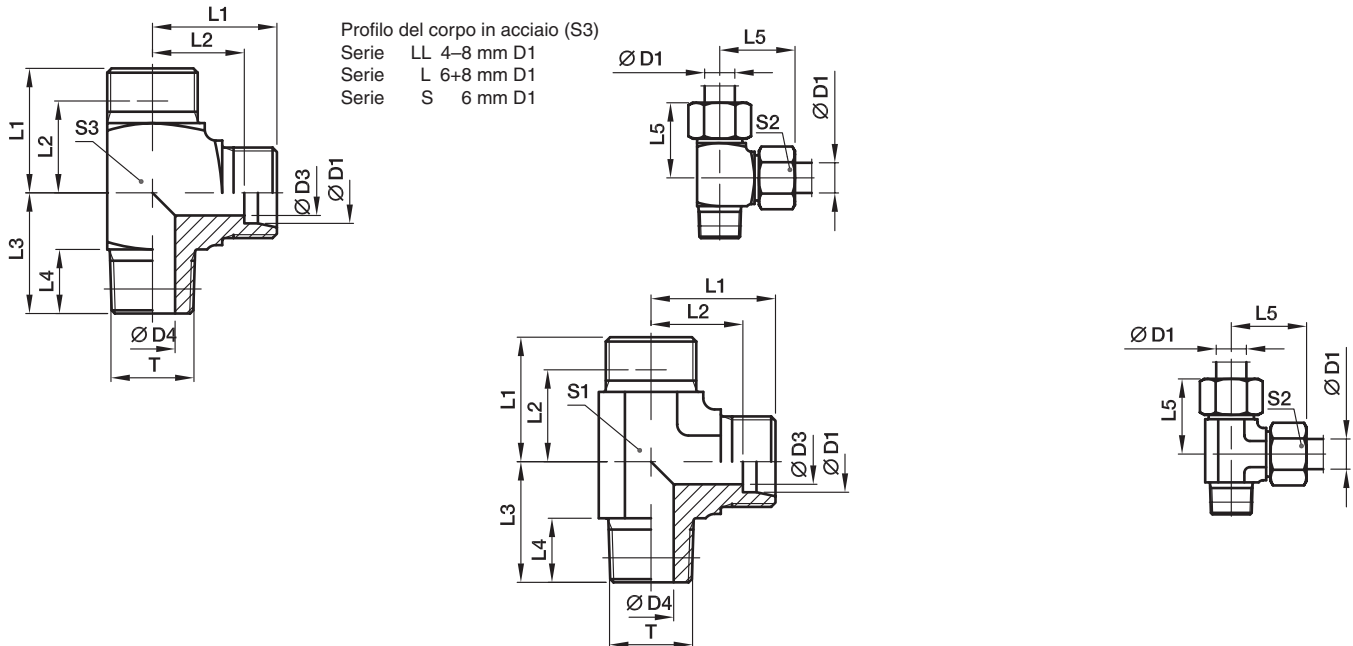

Serie	D1	T	D3	D4	L1	L2	L3	L4	L5	S1	S2	S3	Peso g/1 pezzo	Codice di ordinazione*	PN (bar) ¹⁾	
															CF	71
LL ²⁾	04	R 1/8 keg.	3,0	4,0	15	11,0	17	8	21	9	10	11	20	LE04LLR	100	100
	06	R 1/8 keg.	4,5	4,5	15	9,5	17	8	21	9	12	11	21	LE06LLR	100	100
	08	R 1/8 keg.	6,0	6,0	17	11,5	20	8	23	12	14	12	28	LE08LLR	100	100
L ³⁾	06	R 1/8 keg.	4,0	4,0	19	12,0	20	8	27	12	14	12	40	LE06LR	315	315
	08	R 1/4 keg.	6,0	6,0	21	14,0	26	12	29	12	17	14	57	LE08LR	315	315
	10	R 1/4 keg.	8,0	7,0	22	15,0	27	12	30	14	19		50	LE10LR	315	315
	12	R 3/8 keg.	10,0	9,0	24	17,0	28	12	32	17	22		60	LE12LR	315	315
	15	R 1/2 keg.	12,0	11,0	28	21,0	34	14	36	19	27		115	LE15LR	315	315
	18	R 1/2 keg.	15,0	14,0	31	23,5	36	14	40	24	32		145	LE18LR	315	315
S ⁴⁾	06	R 1/4 keg.	4,0	4,0	23	16,0	26	12	31	12	17	14	71	LE06SR	400	400
	08	R 1/4 keg.	5,0	5,0	24	17,0	27	12	32	14	19		62	LE08SR	400	400
	10	R 3/8 keg.	7,0	7,0	25	17,5	28	12	34	17	22		82	LE10SR	400	400
	12	R 3/8 keg.	8,0	8,0	29	21,5	28	12	38	17	24		102	LE12SR	400	400
	14	R 1/2 keg.	10,0	10,0	30	22,0	32	14	40	19	27		130	LE14SR	400	400
	16	R 1/2 keg.	12,0	12,0	33	24,5	32	14	43	24	30		193	LE16SR	400	400

¹⁾ Pressione indicata = Articolo disponibile

²⁾ LL = Serie ultraleggera; ³⁾ L = Serie leggera; ⁴⁾ S = Serie pesante

$$\frac{PN(\text{bar})}{10} = PN(\text{MPa})$$

Consegna senza dado né anello. Per informazioni sull'ordinazione di raccordi completi vedere pag. 17.

*Aggiungere i **suffissi** qui di seguito in base al materiale e alla superficie richiesti.

Suffissi codice di ordinazione		
Materiale	Suffisso superficie e materiale	Esempio
Acciaio, zincato, esente da CromoVI	CFX	LE16SRCFX
Acciaio inossidabile	71X	LE16SR71X

LE-M(KEG) T di derivazione con terminale maschio

Estremità conica EO 24° / Filettatura maschio metrica conica corta (DIN 3852-1, Configurazione C)

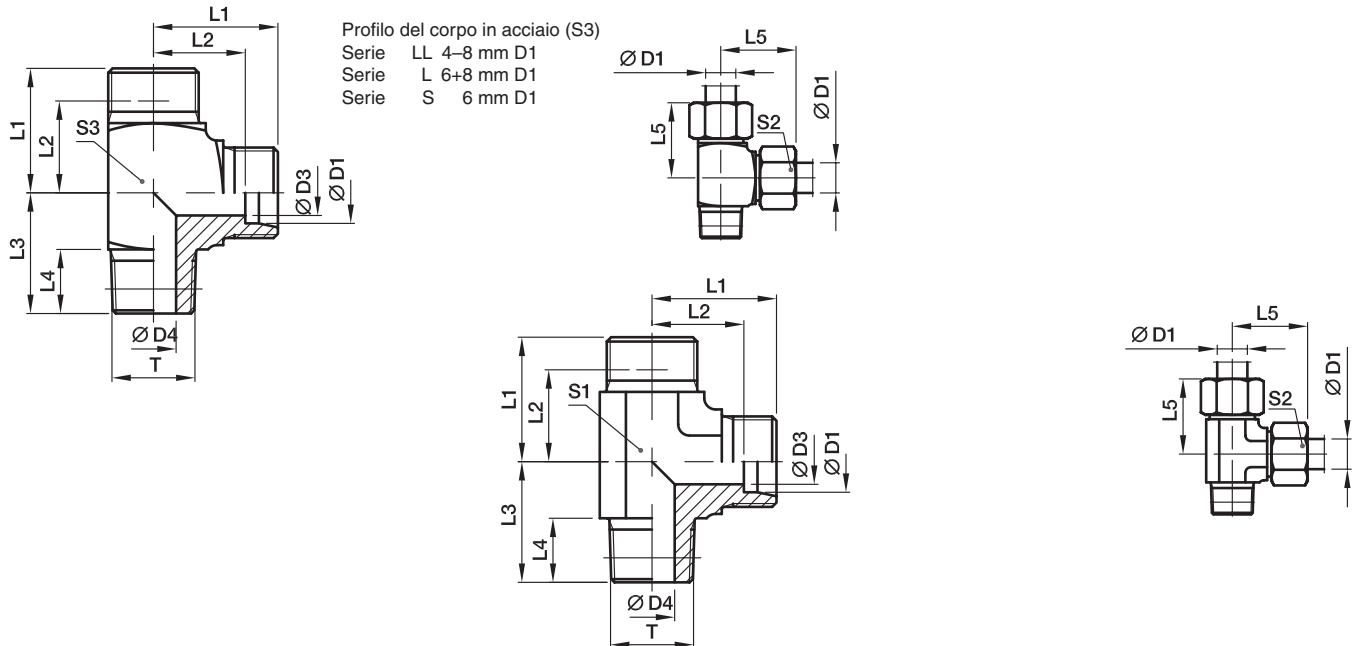

Serie	D1	T	D3	D4	L1	L2	L3	L4	L5	S1	S2	S3	Peso g/1 pezzo	Codice di ordinazione*	PN (bar) ¹⁾	
															CF	71
LL ²⁾	04	M 08×1.0 keg.	3,0	3,5	15	11,0	17	8	21	9	10	9	17	LE04LLM	100	100
	06	M 10×1.0 keg.	4,5	4,5	15	9,5	17	8	21	9	12	11	21	LE06LLM	100	100
	08	M 10×1.0 keg.	6,0	6,0	17	11,5	20	8	23	12	14	12	29	LE08LLM	100	100
L ³⁾	06	M 10×1.0 keg.	4,0	4,0	19	12,0	20	8	27	12	14	12	38	LE06LM	315	315
	08	M 12×1.5 keg.	6,0	6,0	21	14,0	26	12	29	12	17	14	56	LE08LM	315	315
	10	M 14×1.5 keg.	8,0	7,0	22	15,0	27	12	30	14	19		47	LE10LM	315	315
	12	M 16×1.5 keg.	10,0	9,0	24	17,0	28	12	32	17	22		58	LE12LM	315	315
	15	M 18×1.5 keg.	12,0	11,0	28	21,0	32	12	36	19	27		98	LE15LM	315	315
	18	M 22×1.5 keg.	15,0	14,0	31	23,5	36	14	40	24	32		156	LE18LM	315	315
S ⁴⁾	06	M 12×1.5 keg.	4,0	4,0	23	16,0	26	12	31	12	17	14	70	LE06SM	400	400
	08	M 14×1.5 keg.	5,0	5,0	24	17,0	27	12	32	14	19		66	LE08SM	400	400
	10	M 16×1.5 keg.	7,0	7,0	25	17,5	28	12	34	17	22		123	LE10SM	400	400
	12	M 18×1.5 keg.	8,0	8,0	29	21,5	28	12	38	17	24		169	LE12SM	400	400
	14	M 20×1.5 keg.	10,0	10,0	30	22,0	32	14	40	19	27		174	LE14SM	400	400
	16	M 22×1.5 keg.	12,0	12,0	33	24,5	32	14	43	24	30		178	LE16SM	400	400

¹⁾ Pressione indicata = Articolo disponibile

²⁾ LL = Serie ultraleggera; ³⁾ L = Serie leggera; ⁴⁾ S = Serie pesante

$$\frac{PN \text{ (bar)}}{10} = PN \text{ (MPa)}$$

Consegna senza dado né anello. Per informazioni sull'ordinazione di raccordi completi vedere pag. 17.

Suffissi codice di ordinazione		
Materiale	Suffisso superficie e materiale	Esempio
Acciaio, zincato, esente da CromoVI	CFX	LE16SMCFX
Acciaio inossidabile	71X	LE16SM71X

*Aggiungere i suffissi qui di seguito in base al materiale e alla superficie richiesti.

GAI-M Terminale diritto femmina

Filettatura femmina metrica (ISO 9974-1) / Estremità conica EO 24°

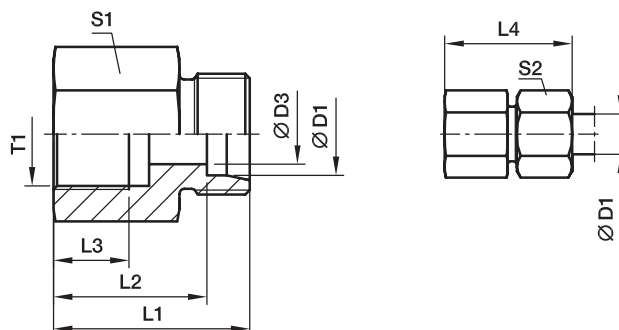

Serie	D1	T1	D3	L1	L2	L3	L4	S1	S2	Peso g/1 pezzo	Codice di ordinazione*	PN (bar) ¹⁾	
												CF	71
L ³⁾	06	M 10x1,0	4	26,5	19,5	8,0	34	14	14	18	GAI06LM	315	315
	08	M 12x1,5	6	31,0	24,0	12,0	39	17	17	32	GAI08LM	315	315
	10	M 14x1,5	8	32,0	25,0	12,0	40	19	19	39	GAI10LM	315	315
	12	M 16x1,5	10	33,0	26,0	12,0	41	22	22	52	GAI12LM	315	315
	15	M 18x1,5	12	35,0	28,0	12,0	43	24	27	68	GAI15LM	315	315
	18	M 22x1,5	15	37,0	29,5	14,0	46	30	32	111	GAI18LM	315	315
	22	M 26x1,5	19	42,0	34,5	16,0	51	32	36	123	GAI22LM	160	160
	28	M 33x2,0	24	45,0	37,5	18,0	54	41	41	211	GAI28LM	160	160
	35	M 42x2,0	30	51,0	40,5	20,0	62	55	50	459	GAI35LM	160	160
	42	M 48x2,0	36	53,0	42,0	22,0	65	60	60	522	GAI42LM	160	160
S ⁴⁾	06	M 12x1,5	4	33,0	26,0	12,0	41	17	17	35	GAI06SM	400	400
	08	M 14x1,5	5	33,0	26,0	12,0	41	17	19	42	GAI08SM	400	400
	10	M 16x1,5	7	34,0	26,5	12,0	43	22	22	58	GAI10SM	400	400
	12	M 18x1,5	8	35,0	27,5	12,0	44	24	24	70	GAI12SM	400	400
	14	M 20x1,5	10	39,0	31,0	14,0	49	27	27	95	GAI14SM	400	400
	16	M 22x1,5	12	39,0	30,5	14,0	49	30	30	114	GAI16SM	400	400
	20	M 27x2,0	16	45,0	34,5	16,0	56	36	36	189	GAI20SM	315	315
	25	M 33x2,0	20	49,0	37,0	18,0	61	41	46	235	GAI25SM	315	315
	30	M 42x2,0	25	55,0	41,5	20,0	68	55	50	490	GAI30SM	315	315
	38	M 48x2,0	32	59,0	43,0	22,0	74	60	60	597	GAI38SM	250	250

¹⁾ Pressione indicata = Articolo disponibile

³⁾ L = Serie leggera; ⁴⁾ S = Serie pesante

$\frac{PN \text{ (bar)}}{10} = PN \text{ (MPa)}$

Consegna senza dado né anello. Per informazioni sull'ordinazione di raccordi completi vedere pag. 17.

*Aggiungere i **suffissi** qui di seguito in base al materiale e alla superficie richiesti.

Suffissi codice di ordinazione		
Materiale	Suffisso superficie e materiale	Esempio
Acciaio, zincato, esente da CromoVI	CFX	GAI16SMCFX
Acciaio inossidabile	71X	GAI16SM71X

GAI-R Terminale diritto femmina

Fillettatura femmina BSPP (ISO 1179-1) / Estremità conica EO 24°

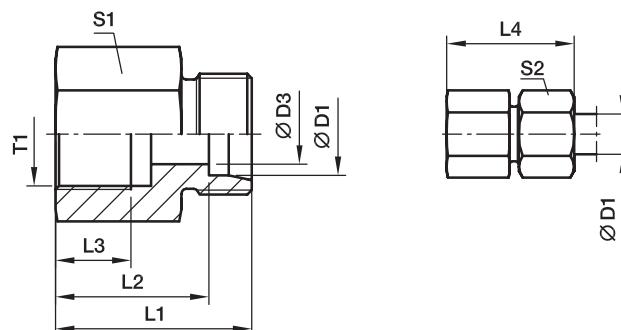

Serie	D1	T1	D3	L1	L2	L3	L4	S1	S2	Peso g/1 pezzo	Codice di ordinazione*	PN (bar) ¹⁾		
												CF	71	MS
L ³⁾	06	G 1/8	4	26,0	19,0	8,0	34	14	14	18	GAI06LR	315	315	200
	06	G 1/4	4	31,0	24,0	12,0	39	19	14	39	GAI06LR1/4	315	315	200
	08	G 1/4	6	31,0	24,0	12,0	39	19	17	39	GAI08LR	315	315	200
	08	G 3/8	6	32,0	25,0	12,0	40	24	17	61	GAI08LR3/8	315	315	200
	08	G 1/2	6	36,0	29,0	14,0	44	27	17	80	GAI08LR1/2	315	315	200
	10	G 1/4	8	32,0	25,0	12,0	40	19	19	40	GAI10LR	315	315	200
	10	G 3/8	8	33,0	26,0	12,0	41	24	19	63	GAI10LR3/8	315	315	200
	10	G 1/2	8	37,0	30,0	14,0	45	27	19	81	GAI10LR1/2	315	315	200
	12	G 3/8	10	33,0	26,0	12,0	41	24	22	64	GAI12LR	315	315	200
	12	G 1/2	10	37,0	30,0	14,0	45	27	22	83	GAI12LR1/2	315	315	200
	15	G 1/2	12	38,0	31,0	14,0	46	27	27	87	GAI15LR	315	315	200
	18	G 1/2	15	38,0	30,5	14,0	47	27	32	89	GAI18LR	315	315	200
	18	G 3/8	15	34,0	26,5	12,0	43	27	32	95	GAI18LR3/8	315	315	200
	22	G 3/4	19	43,0	35,5	16,0	52	36	36	173	GAI22LR	160	160	100
	28	G 1	24	45,5	38,0	18,0	55	41	41	211	GAI28LR	160	160	100
	35	G 1 1/4	30	51,5	41,0	20,0	63	55	50	469	GAI35LR	160	160	100
	42	G 1 1/2	36	53,5	42,5	22,0	65	60	60	540	GAI42LR	160	160	100
	S ⁴⁾	06	G 1/4	4	33,0	26,0	12,0	41	19	17	43	GAI06SR	400	400
08		G 1/4	5	33,0	26,0	12,0	41	19	19	47	GAI08SR	400	400	
10		G 3/8	7	34,0	26,5	12,0	43	24	22	68	GAI10SR	400	400	
12		G 3/8	8	34,0	26,5	12,0	43	24	24	71	GAI12SR	400	400	
12		G 1/2	8	38,0	30,5	14,0	47	30	24	121	GAI12SR1/2	400	400	
14		G 1/2	10	40,0	32,0	14,0	50	30	27	125	GAI14SR	400	400	
16		G 1/2	12	40,0	31,5	14,0	50	30	30	126	GAI16SR	400	400	
20		G 3/4	16	45,0	34,5	16,0	56	36	36	196	GAI20SR	315	315	
25		G 1	20	49,5	37,5	18,0	62	41	46	246	GAI25SR	315	315	
30		G 1 1/4	25	55,5	42,0	22,0	69	55	50	537	GAI30SR	315	315	
38		G 1 1/2	32	59,5	43,5	22,0	74	60	60	649	GAI38SR	250	250	

¹⁾ Pressione indicata = Articolo disponibile

³⁾ L = Serie leggera; ⁴⁾ S = Serie pesante

$$\frac{PN \text{ (bar)}}{10} = PN \text{ (MPa)}$$

Consegna senza dado né anello. Per informazioni sull'ordinazione di raccordi completi vedere pag. 17.

*Aggiungere i **suffissi** qui di seguito in base al materiale e alla superficie richiesti.

Suffissi codice di ordinazione		
Materiale	Suffisso superficie e materiale	Esempio
Acciaio, zincato, esente da CromoVI	CFX	GAI16SRCFX
Acciaio inossidabile	71X	GAI16SR71X
Ottone	MSX	GAI16SRMSX

GAI-NPT Terminale diritto femmina

Filettatura femmina NPT (SAE 476) / Estremità conica EO 24°

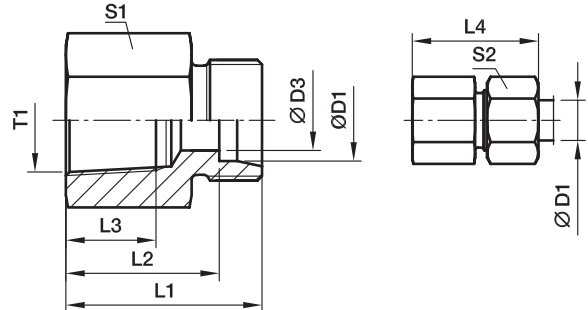

Serie	D1	T1	D3	L1	L2	L3	L4	S1	S2	Peso g/1 pezzo	Codice di ordinazione*	PN (bar) ¹⁾	
												CF	71
L ³⁾	06	1/8-27 NPT	4	26,0	19,0	11,6	34	14	14	19	GAI06L1/8NPT	315	315
	06	1/4-18 NPT	4	30,5	23,5	16,4	38	19	14	38	GAI06L1/4NPT	315	315
	08	1/4-18 NPT	6	30,5	23,5	16,4	38	19	17	39	GAI08L1/4NPT	315	315
	10	1/4-18 NPT	8	31,0	24,0	16,4	39	19	19	40	GAI10L1/4NPT	315	315
	12	3/8-18 NPT	10	34,0	27,0	17,4	42	24	22	69	GAI12L3/8NPT	315	315
	12	1/2-14 NPT	10	39,0	32,0	22,6	47	27	22	91	GAI12L1/2NPT	315	315
	15	1/2-14 NPT	12	40,0	33,0	22,6	48	27	27	96	GAI15L1/2NPT	315	315
	18	1/2-14 NPT	15	40,0	32,5	22,6	49	27	32	99	GAI18L1/2NPT	315	315
	22	3/4-14 NPT	19	43,0	35,5	23,1	52	36	36	184	GAI22L3/4NPT	160	160
	28	1-11,5 NPT	24	48,0	40,5	27,8	57	41	41	238	GAI28L1NPT	160	160
	35	1 1/4-11,5 NPT	30	51,0	40,5	28,3	62	55	50	424	GAI35L11/4NPT	160	160
	42	1 1/2-11,5 NPT	36	53,0	42,0	28,3	65	60	60	547	GAI42L11/2NPT	160	160
S ⁴⁾	06	1/8-27 NPT	4	29,0	22,0	11,6	36	14	17	25	GAI06S1/8NPT	400	400
	06	1/4-18 NPT	4	33,0	26,0	16,4	41	19	17	41	GAI06S1/4NPT	400	400
	08	1/4-18 NPT	5	33,0	26,0	16,4	41	19	19	42	GAI08S1/4NPT	400	400
	10	3/8-18 NPT	7	35,0	27,0	17,4	44	24	22	74	GAI10S3/8NPT	400	400
	12	1/4-18 NPT	8	32,5	25,0	16,4	41	22	24	81	GAI12S1/4NPT	400	400
	12	3/8-18 NPT	8	35,0	27,5	17,4	44	24	24	76	GAI12S3/8NPT	400	400
	12	1/2-14 NPT	8	41,0	33,5	22,6	50	27	24	101	GAI12S1/2NPT	400	400
	14	1/2-14 NPT	10	43,0	35,0	22,6	53	27	27	108	GAI14S1/2NPT	400	400
	16	1/2-14 NPT	12	43,0	34,5	22,6	50	27	30	111	GAI16S1/2NPT	400	400
	20	1/2-14 NPT	16	44,0	33,5	22,6	55	32	36	129	GAI20S1/2NPT	315	315
	20	3/4-14 NPT	16	46,0	35,5	23,1	57	36	36	214	GAI20S3/4NPT	315	315
	25	1-11,5 NPT	20	53,0	41,0	27,8	65	41	46	288	GAI25S1NPT	315	315
	30	1 1/4-11,5 NPT	25	57,0	43,5	28,3	70	55	50	559	GAI30S11/4NPT	315	315
	38	1 1/2-11,5 NPT	32	59,0	43,0	28,3	74	60	60	632	GAI38S11/2NPT	250	250

¹⁾ Pressione indicata = Articolo disponibile

³⁾ L = Serie leggera; ⁴⁾ S = Serie pesante

$\frac{PN (bar)}{10} = PN (MPa)$

Consegna senza dado né anello. Per informazioni sull'ordinazione di raccordi completi vedere pag. 17.

*Aggiungere i **suffissi** qui di seguito in base al materiale e alla superficie richiesti.

Suffissi codice di ordinazione		
Materiale	Suffisso superficie e materiale	Esempio
Acciaio, zincato, esente da CromoVI	CFX	GAI16S1/2NPTCFX
Acciaio inossidabile	71X	GAI16S1/2NPT71X

RI-ED Raccordo riduzione/espansione filettatura

Filettatura maschio BSPP – Guarnizione ED (ISO 1179) / Filettatura femmina BSPP (ISO 1179-1)

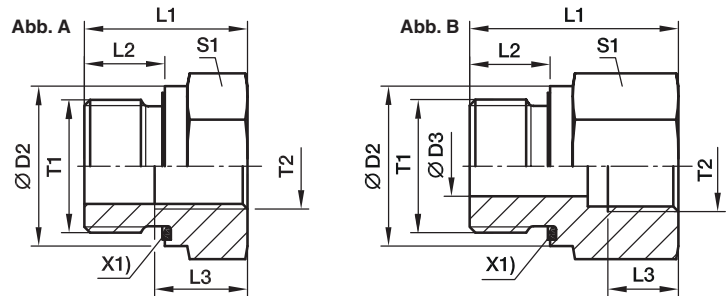

X1) Guarnizione Eolastic ED

Terminale maschio T1	Terminale femmina T2	D2	D3	L1	L2	L3	S1	Fig.	Peso g/1 pezzo	Codice di ordinazione*	PN (bar) ¹⁾	
											CF	71
G 1/8 A	G 1/4	14	4	31,0	8	12,0	19	B	41	RI1/8EDX1/4	400	400
G 1/8 A	G 3/8	14	4	32,0	8	12,0	24	B	63	RI1/8EDX3/8	400	400
G 1/4 A	G 1/8	19	5	29,0	12	8,0	19	B	41	RI1/4EDX1/8	400	400
G 1/4 A	G 3/8	19	5	36,0	12	12,0	24	B	69	RI1/4EDX3/8	400	400
G 1/4 A	G 1/2	19	5	40,0	12	14,0	30	B	120	RI1/4EDX1/2	400	400
G 1/4 A	G 3/4	19	5	43,0	12	16,0	36	B	171	RI1/4EDX3/4	400	400
G 3/8 A	G 1/8	22		22,5	12	8,0	22	A	38	RI3/8EDX1/8	400	400
G 3/8 A	G 1/4	22	8	36,0	12	12,0	22	B	68	RI3/8EDX1/4	400	400
G 3/8 A	G 1/2	22	8	41,0	12	14,0	30	B	124	RI3/8EDX1/2	400	400
G 3/8 A	G 3/4	22	8	44,0	12	16,0	36	B	182	RI3/8EDX3/4	315	315
G 1/2 A	G 1/8	27		24,0	14	8,0	27	A	65	RI1/2EDX1/8	400	400
G 1/2 A	G 1/4	27		24,0	14	12,0	27	A	56	RI1/2EDX1/4	400	400
G 1/2 A	G 3/8	27	12	37,0	14	12,0	27	B	95	RI1/2EDX3/8	400	400
G 1/2 A	G 3/4	27	12	46,0	14	16,0	36	B	183	RI1/2EDX3/4	315	315
G 1/2 A	G 1	27	12	49,0	14	18,0	41	B	232	RI1/2EDX1	315	315
G 1/2 A	G 1 1/4	27	10	53,0	14	20,0	55	B	481	RI1/2EDX11/4	315	315
G 3/4 A	G 1/4	32		26,0	16	12,0	32	A	103	RI3/4EDX1/4	315	315
G 3/4 A	G 3/8	32		26,0	16	12,0	32	A	86	RI3/4EDX3/8	315	315
G 3/4 A	G 1/2	32	16	43,0	16	14,0	32	B	156	RI3/4EDX1/2	315	315
G 3/4 A	G 1	32	16	51,0	16	18,0	41	B	237	RI3/4EDX1	315	315
G 3/4 A	G 1 1/4	32	16	55,0	16	20,0	55	B	486	RI3/4EDX11/4	315	315
G 3/4 A	G 1 1/2	32	16	57,0	16	22,0	60	B	561	RI3/4EDX11/2	250	250
G 1 A	G 1/4	40		29,0	18	12,0	41	A	197	RI1EDX1/4	315	315
G 1 A	G 3/8	40		29,0	18	12,0	41	A	179	RI1EDX3/8	315	315
G 1 A	G 1/2	40		29,0	18	14,0	41	A	153	RI1EDX1/2	315	315
G 1 A	G 3/4	40	20	49,0	18	16,0	41	B	290	RI1EDX3/4	315	315
G 1 A	G 1 1/4	40	20	57,0	18	20,0	55	B	503	RI1EDX11/4	315	315
G 1 A	G 1 1/2	40	20	59,0	18	22,0	60	B	585	RI1EDX11/2	250	250
G 1 1/4 A	G 1/2	50		32,0	20	14,0	50	A	313	RI11/4EDX1/2	315	315
G 1 1/4 A	G 3/4	50		32,0	20	16,0	50	A	393	RI11/4EDX3/4	315	315
G 1 1/4 A	G 1	50	25	52,0	20	18,0	50	B	469	RI11/4EDX1	315	315
G 1 1/4 A	G 1 1/2	50	25	60,0	20	22,0	60	B	624	RI11/4EDX11/2	250	250
G 1 1/2 A	G 1/2	55		36,0	22	14,0	55	A	470	RI11/2EDX1/2	250	250
G 1 1/2 A	G 3/4	55		36,0	22	16,0	55	A	415	RI11/2EDX3/4	250	250
G 1 1/2 A	G 1	55		36,0	22	18,0	55	A	338	RI11/2EDX1	250	250
G 1 1/2 A	G 1 1/4	55	32	58,0	22	20,0	55	B	542	RI11/2EDX11/4	250	250
G 2 A	G 1 1/2	75	40	65,0	24	22,0	75	B	1309	RI2EDX11/2	160	

¹⁾ Pressione indicata = Articolo disponibile

$$\frac{PN \text{ (bar)}}{10} = PN \text{ (MPa)}$$

Per informazioni sui materiali di tenuta alternativi vedere pag. I7.

*Aggiungere i suffissi qui di seguito in base al materiale e alla superficie richiesti.

Suffissi codice di ordinazione			
Materiale	Suffisso superficie e materiale	Esempio	Materiale di tenuta standard (non occorre suffisso aggiuntivo)
Acciaio, zincato, esente da CromoVI	CF	RI1EDX1/2CF	NBR
Acciaio inossidabile	71	RI1EDX1/271	VIT

RI Raccordo riduzione/espansione filettatura

Filettatura maschio BSPP – bordo di tenuta metallico (ISO 1179) /
Filettatura femmina BSPP (ISO 1179-1)

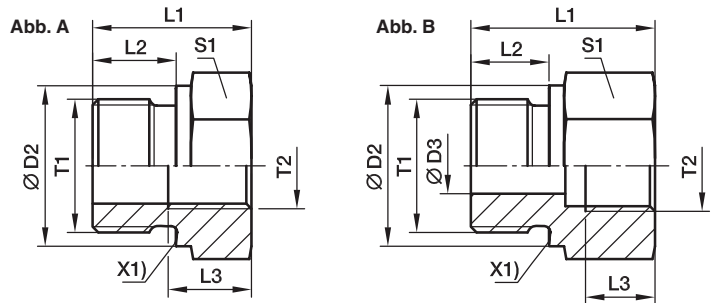

X1) Bordo di tenuta metallico

Terminale maschio T1	Terminale femmina T2	D2	D3	L1	L2	L3	S1	Fig.	Peso g/1 pezzo	Codice di ordinazione*	PN (bar) ¹⁾		
											CF	71	MS
G 1/8 A	G 1/4	14	4	31,0	8	12,0	19	B	42	RI1/8X1/4	400	400	250
G 1/8 A	G 3/8	14	4	32,0	8	12,0	24	B	63	RI1/8X3/8	400	400	250
G 1/4 A	G 1/8	18	5	28,0	12	8,0	19	B	38	RI1/4X1/8	400	400	250
G 1/4 A	G 3/8	18	5	36,0	12	12,0	24	B	69	RI1/4X3/8	400	400	250
G 1/4 A	G 1/2	18	5	40,0	12	14,0	30	B	116	RI1/4X1/2	400	400	250
G 1/4 A	G 3/4	18	5	43,0	12	16,0	36	B	170	RI1/4X3/4	315	315	200
G 3/8 A	G 1/8	22		22,5	12	8,0	22	A	39	RI3/8X1/8	400	400	250
G 3/8 A	G 1/4	22	8	36,0	12	12,0	22	B	68	RI3/8X1/4	400	400	250
G 3/8 A	G 1/2	22	8	41,0	12	14,0	30	B	125	RI3/8X1/2	400	400	250
G 3/8 A	G 3/4	22	8	44,0	12	16,0	36	B	183	RI3/8X3/4	315	315	200
G 1/2 A	G 1/8	26		24,0	14	8,0	27	A	66	RI1/2X1/8	400	400	250
G 1/2 A	G 1/4	26		24,0	14	12,0	27	A	56	RI1/2X1/4	315	315	200
G 1/2 A	G 3/8	26	12	37,0	14	12,0	27	B	94	RI1/2X3/8	315	315	200
G 1/2 A	G 3/4	26	12	46,0	14	16,0	36	B	182	RI1/2X3/4	315	315	200
G 1/2 A	G 1	26	12	49,0	14	18,0	41	B	221	RI1/2X1	315	315	200
G 1/2 A	G 1 1/4	26	10	53,0	14	20,0	55	B	482	RI1/2X11/4	160	160	
G 3/4 A	G 1/4	32		26,0	16	12,0	32	A	103	RI3/4X1/4	315	315	200
G 3/4 A	G 3/8	32		26,0	16	12,0	32	A	87	RI3/4X3/8	315	315	200
G 3/4 A	G 1/2	32	16	40,0	16	14,0	32	B	143	RI3/4X1/2	315	315	200
G 3/4 A	G 1	32	16	51,0	16	18,0	41	B	235	RI3/4X1	315	315	200
G 3/4 A	G 1 1/4	32	16	55,0	16	20,0	55	B	481	RI3/4X11/4	160	160	
G 3/4 A	G 1 1/2	32	16	57,0	16	22,0	60	B	560	RI3/4X11/2	160	160	
G 1 A	G 1/4	39		29,0	18	12,0	41	A	195	RI1X1/4	315	315	
G 1 A	G 3/8	39		29,0	18	12,0	41	A	179	RI1X3/8	315	315	200
G 1 A	G 1/2	39		29,0	18	14,0	41	A	157	RI1X1/2	315	315	200
G 1 A	G 3/4	39	20	47,0	18	16,0	41	B	278	RI1X3/4	315	315	200
G 1 A	G 1 1/4	39	20	57,0	18	20,0	55	B	530	RI1X11/4	160	160	100
G 1 A	G 1 1/2	39	20	59,0	18	22,0	60	B	585	RI1X11/2	160	160	100
G 1 1/4 A	G 1/2	49		32,0	20	14,0	50	A	308	RI11/4X1/2	160	160	100
G 1 1/4 A	G 3/4	49		32,0	20	16,0	50	A	267	RI11/4X3/4	160	160	100
G 1 1/4 A	G 1	49	25	52,0	20	18,0	50	B	458	RI11/4X1	160	160	100
G 1 1/4 A	G 1 1/2	49	25	60,0	20	22,0	60	B	616	RI11/4X11/2	160	160	100
G 1 1/2 A	G 1/2	55		36,0	22	14,0	55	A	477	RI11/2X1/2	160	160	100
G 1 1/2 A	G 3/4	55		36,0	22	16,0	55	A	402	RI11/2X3/4	160	160	100
G 1 1/2 A	G 1	55		36,0	22	18,0	55	A	337	RI11/2X1	160	160	100
G 1 1/2 A	G 1 1/4	55	32	58,0	22	20,0	55	B	542	RI11/2X11/4	160	160	100
G 2 A	G 1 1/2	68	40	62,0	24	22,0	70	B	990	RI2X11/2	160		

¹⁾ Pressione indicata = Articolo disponibile

$$\frac{PN \text{ (bar)}}{10} = PN \text{ (MPa)}$$

*Aggiungere i **suffixi** qui di seguito in base al materiale e alla superficie richiesti.

Suffixi codice di ordinazione		
Materiale	Suffixo superficie e materiale	Esempio
Acciaio, zincato, esente da CromoVI	CFX	RI1X1/2CFX
Acciaio inossidabile	71X	RI1X1/271X
Ottone	MSX	RI1X1/2MSX

MAV Connettore per manometro

Filettatura femmina BSPP / Estremità conica EO 24°

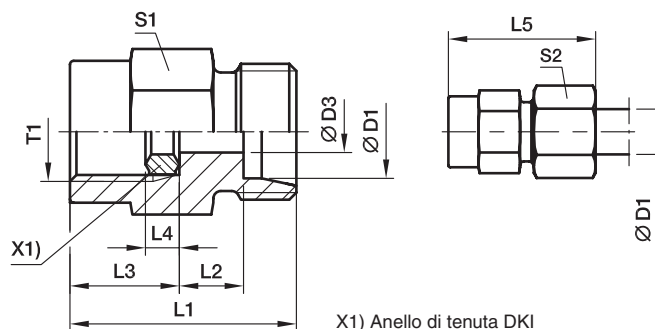

Serie	D1	T1	D3	L1	L2	L3	L4	L5	S1	S2	Peso g/1 pezzo	Codice di ordinazione*	PN (bar) ¹⁾		
													CF	71	MS
LL ²⁾	04	G 1/4	2,5	27	8,5	14,5	4,5	33	19	10	33	MAV04LLROMD	100		
L ³⁾	06	G 1/4	2,5	29	7,5	14,5	4,5	37	19	14	37	MAV06LROMD	315	315	200
	08	G 1/4	5,5	29	7,5	14,5	4,5	37	19	17	38	MAV08LROMD	315	315	200
	10	G 1/4	5,5	30	8,5	14,5	4,5	38	19	19	41	MAV10LROMD	315	315	200
	12	G 1/4	5,5	30	8,5	14,5	4,5	38	19	22	43	MAV12LROMD	315	315	200
S ⁴⁾	06	G 1/2	3,5	38	11,0	20,0	5,0	46	27	17	86	MAV06SROMD	630	630	400
	08	G 1/2	3,5	38	11,0	20,0	5,0	46	27	19	86	MAV08SROMD	630	630	400
	10	G 1/2	7,5	38	10,5	20,0	5,0	47	27	22	88	MAV10SROMD	630	630	400
	12	G 1/2	7,5	38	10,5	20,0	5,0	47	27	24	93	MAV12SROMD	630	630	400

¹⁾ Pressione indicata = Articolo disponibile

²⁾ LL = Serie ultraleggera; ³⁾ L = Serie leggera; ⁴⁾ S = Serie pesante

$\frac{PN \text{ (bar)}}{10} = PN \text{ (MPa)}$

Consegna senza dado né anello. Per informazioni sull'ordinazione di raccordi completi vedere pag. I7.

*Aggiungere i **suffissi** qui di seguito in base al materiale e alla superficie richiesti.

Suffissi codice di ordinazione		
Materiale	Suffisso superficie e materiale	Esempio
Acciaio, zincato, esente da CromoVI	CF	MAV10SROMDCF
Acciaio inossidabile	71	MAV10SROMD71
Ottone	MS	MAV10SROMDMS

MAVE Connettore per manometro con dado girevole

Filettatura femmina BSPP / Dado girevole EO 24° DKO

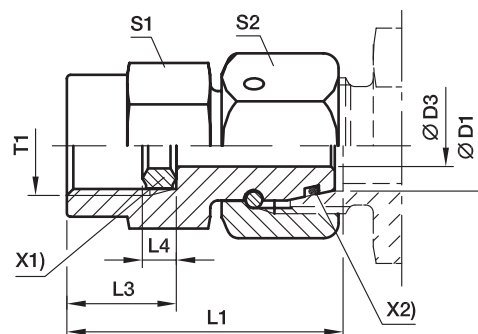

X1) Anello di tenuta DKO
X2) O-ring OR

Serie	D1 	T1	D3	L1	L3	L4	S1	S2	Peso g/1 pezzo	Codice di ordinazione*	PN (bar) ¹⁾	
											CF	71
L ³⁾	06	G 1/4	2,5	35,5	14,5	4,5	19	14	46	MAVE06LR	315	315
	08	G 1/4	4,0	35,5	14,5	4,5	19	17	52	MAVE08LR	315	315
	10	G 1/4	5,5	36,0	14,5	4,5	19	19	59	MAVE10LR	315	315
	12	G 1/4	5,5	36,0	14,5	4,5	19	22	70	MAVE12LR	315	315
S ⁴⁾	06	G 1/2	2,5	42,5	20,0	5,0	27	17	95	MAVE06SR	630	630
	06	G 1/4	2,5	35,5	14,5	4,5	19	17	52	MAVE06SR1/4	630	630
	08	G 1/2	4,0	43,0	20,0	5,0	27	19	100	MAVE08SR	630	630
	08	G 1/4	4,0	35,5	14,5	4,5	19	19	58	MAVE08SR1/4	630	630
	10	G 1/2	6,0	43,5	20,0	5,0	27	22	109	MAVE10SR	630	630
	10	G 1/4	7,0	39,0	14,5	4,5	19	22	67	MAVE10SR1/4	630	630
	12	G 1/2	7,0	45,0	20,0	5,0	27	24	125	MAVE12SR	630	630
	12	G 1/4	7,0	39,0	14,5	4,5	19	24	83	MAVE12SR1/4	630	630

1) Pressione indicata = Articolo disponibile

3) L = Serie leggera; 4) S = Serie pesante

$$\frac{\text{PN (bar)}}{10} = \text{PN (MPa)}$$

Per informazioni sull'ordinazione di materiali di tenuta alternativi vedere pag. I7.

*Aggiungere i **suffissi** qui di seguito in base al materiale e alla superficie richiesti.

Suffissi codice di ordinazione			
Materiale	Suffisso superficie e materiale	Esempio	Materiale di tenuta standard (non occorre suffisso aggiuntivo)
Acciaio, zincato, esente da CromoVI	CF	MAVE10SRCF	NBR
Acciaio inossidabile	71	MAVE10SR71	VIT

ROV Tappo protettivo per estremità tubi

Estremità conica EO 24°

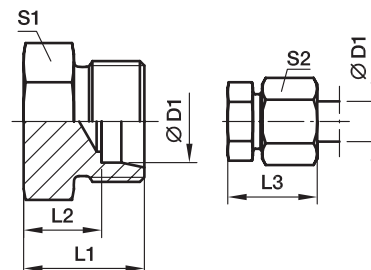

Serie	D1 	L1	L2	L3	S1	S2	Peso g/1 pezzo	Codice di ordinazione*	PN (bar) ¹⁾	
									CF	71
L ³⁾	06	14	7,0	22	12	14	8	ROV06L	315	315
	08	15	8,0	23	14	17	13	ROV08L	315	315
	10	16	9,0	24	17	19	17	ROV10L	315	315
	12	17	10,0	25	19	22	24	ROV12L	315	315
	15	18	11,0	26	24	27	41	ROV15L	315	315
	18	19	11,5	28	27	32	56	ROV18L	315	315
	22	21	13,5	30	32	36	84	ROV22L	160	160
	28	22	14,5	31	41	41	138	ROV28L	160	160
	35	25	14,5	36	46	50	203	ROV35L	160	160
	42	27	16,0	39	55	60	318	ROV42L	160	160
S ⁴⁾	06	18	11,0	26	14	17	17	ROV06S	630	630
	08	20	13,0	28	17	19	28	ROV08S	630	630
	10	20	12,5	29	19	22	33	ROV10S	630	630
	12	22	14,5	31	22	24	50	ROV12S	630	630
	14	24	16,0	34	24	27	62	ROV14S	630	630
	16	24	15,5	34	27	30	75	ROV16S	400	400
	20	28	17,5	39	32	36	125	ROV20S	400	400
	25	32	20,0	44	41	46	229	ROV25S	400	400
	30	34	20,5	47	46	50	310	ROV30S	400	400
	38	39	23,0	54	55	60	508	ROV38S	315	315

¹⁾ Pressione indicata = Articolo disponibile

³⁾ L = Serie leggera: ⁴⁾ S = Serie pesante

$\frac{PN \text{ (bar)}}{10} = PN \text{ (MPa)}$

Consegna senza dado né anello. Per informazioni sull'ordinazione di raccordi completi vedere pag. 17.

*Aggiungere i **suffissi** qui di seguito in base al materiale e alla superficie richiesti.

Suffissi codice di ordinazione		
Materiale	Suffisso superficie e materiale	Esempio
Acciaio, zincato, esente da CromoVI	CFX	ROV16SCFX
Acciaio inossidabile	71X	ROV16S71X

VSTI M-OR Tappo protettivo per connessioni

Filettatura maschio metrica – O-ring (ISO 6149)

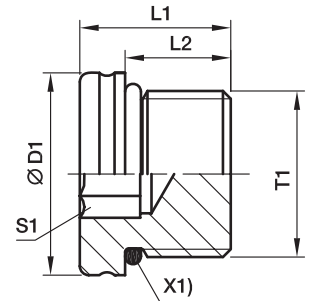

X1) O-ring OR

T1	D1	L1	L2	S1	Peso g/1 pezzo	Codice di ordinazione*	PN (bar) ¹⁾ CF
M 08x1,0	12	13,0	9,5	4	6	VSTI8X1OR	630
M 10x1,0	13	13,5	9,5	5	8	VSTI10X1OR	630
M 12x1,5	17	15,0	11,0	6	14	VSTI12X1.5OR	630
M 14x1,5	19	16,0	11,0	6	20	VSTI14X1.5OR	630
M 16x1,5	21	17,5	12,5	8	26	VSTI16X1.5OR	630
M 18x1,5	23	19,0	14,0	8	37	VSTI18X1.5OR	630
M 22x1,5	27	20,0	15,0	10	58	VSTI22X1.5OR	630
M 26x1,5	31	21,0	16,0	12	77	VSTI26X1.5OR	400
M 27x2,0	32	23,5	18,5	12	95	VSTI27X2OR	400
M 33x2,0	38	25,0	18,5	14	148	VSTI33X2OR	400
M 42x2,0	48	25,5	19,0	22	233	VSTI42X2OR	400
M 48x2,0	55	28,0	21,5	24	336	VSTI48X2OR	400

1) Pressione indicata = Articolo disponibile

$$\frac{\text{PN (bar)}}{10} = \text{PN (MPa)}$$

Per informazioni sull'ordinazione di materiali di tenuta alternativi vedere pag. I7.

Suffissi codice di ordinazione			
Materiale	Suffisso superficie e materiale	Esempio	Materiale di tenuta standard (non occorre suffisso aggiuntivo)
Acciaio, zincato, esente da CromoVI	CF	VSTI18X1.5ORCF	NBR

 *Aggiungere i **suffissi** qui di seguito in base al materiale e alla superficie richiesti.

VSTI M/R-ED Tappo protettivo per connessioni

Filettatura maschio metrica – Guarnizione ED (ISO 9974)

Filettatura maschio BSPP – Guarnizione ED (ISO 1179)

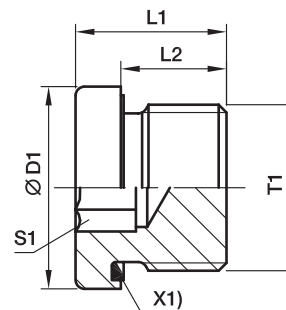

X1) Guarnizione Eolastic ED

Filett. maschio metrica parallela T1	Filettatura BSP terminale maschio T1	D1	L1	L2	S1	Peso g/1 pezzo	Codice di ordinazione*	Codice di ordinazione*	PN (bar) ¹⁾	
									CF	71
M 10×1,0	G 1/8 A	14,0	12,3	8	5	8	VSTI10X1ED	VSTI1/8ED	400	400
M 12×1,5		17,0	17,3	12	6	14	VSTI12X1.5ED		400	400
M 14×1,5	G 1/4 A	19,0	17,3	12	6	20	VSTI14X1.5ED	VSTI1/4ED	400	400
M 16×1,5	G 3/8 A	22,0	17,3	12	8	25	VSTI16X1.5ED	VSTI3/8ED	400	400
M 18×1,5		24,0	17,3	12	8	32	VSTI18X1.5ED		400	400
M 20×1,5		26,0	19,3	14	10	42	VSTI20X1.5ED		400	400
M 22×1,5	G 1/2 A	27,0	19,3	14	10	51	VSTI22X1.5ED	VSTI1/2ED	400	400
M 26×1,5		32,0	21,3	16	12	78	VSTI26X1.5ED		400	400
M 27×2,0	G 3/4 A	32,0	21,3	16	12	79	VSTI27X2ED	VSTI3/4ED	400	400
M 33×2,0	G 1 A	40,0	22,8	16	17	130	VSTI33X2ED	VSTI1ED	400	400
M 42×2,0	G 1 1/4 A	50,0	22,8	16	22	198	VSTI42X2ED	VSTI11/4ED	315	315
M 48×2,0	G 1 1/2 A	55,0	22,8	16	24	263	VSTI48X2ED	VSTI11/2ED	315	315

¹⁾ Pressione indicata = Articolo disponibile

$$\frac{PN(\text{bar})}{10} = PN(\text{MPa})$$

Per informazioni sull'ordinazione di materiali di tenuta alternativi vedere pag. I7.

*Aggiungere i **suffissi** qui di seguito in base al materiale e alla superficie richiesti.

Suffissi codice di ordinazione			
Materiale	Suffisso superficie e materiale	Esempio	Materiale di tenuta standard (non occorre suffisso aggiuntivo)
Acciaio, zincato, esente da CromoVI	CF	VSTI1/2EDCF	NBR
Acciaio inossidabile	71	VSTI1/2ED71	VIT

VKA Tappo protettivo per coni

Dado girevole EO 24° DKO

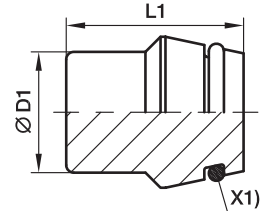

X1) O-ring OR

Serie	D1 	L1	Peso g/1 pezzo	Codice di ordinazione*	PN (bar) ¹⁾		
					CF	71	MS
L ³⁾	06	18,5	6	VKA06	500	315	200
	08	18,5	9	VKA08	500	315	200
	10	20,0	15	VKA10	500	315	200
	12	20,5	21	VKA12	400	315	200
	15	20,5	32	VKA15	400	315	200
	18	22,5	49	VKA18	400	315	200
	22	25,0	80	VKA22	250	160	100
	28	25,5	131	VKA28	250	160	100
	35	30,0	240	VKA35	250	160	100
	42	30,0	343	VKA42	250	160	100
S ⁴⁾	06	18,5	6	VKA06	800	630	400
	08	18,5	9	VKA08	800	630	400
	10	20,0	15	VKA10	800	630	400
	12	20,5	21	VKA12	630	630	400
	14	22,5	30	VKA14	630	630	400
	16	23,5	40	VKA16	630	400	250
	20	28,5	78	VKA20	420	400	250
	25	29,0	120	VKA25	420	400	250
	30	30,5	180	VKA30	420	400	250
	38	33,0	309	VKA38	420	315	200

¹⁾ Pressione indicata = Articolo disponibile

³⁾ L = Serie leggera; ⁴⁾ S = Serie pesante

$\frac{PN \text{ (bar)}}{10} = PN \text{ (MPa)}$

Per informazioni sull'ordinazione di materiali di tenuta alternativi vedere pag. I7.

Suffissi codice di ordinazione			
Materiale	Suffisso superficie e materiale	Esempio	Materiale di tenuta standard (non occorre suffisso aggiuntivo)
Acciaio, zincato, esente da CromoVI	CF	VKA16CF	NBR
Acciaio inossidabile	71	VKA1671	VIT
Ottone	MS	VKA16MS	NBR

*Aggiungere i **suffissi** qui di seguito in base al materiale e alla superficie richiesti.

VKAM Tappo protettivo con dado per coni

Dado girevole EO 24° DKO

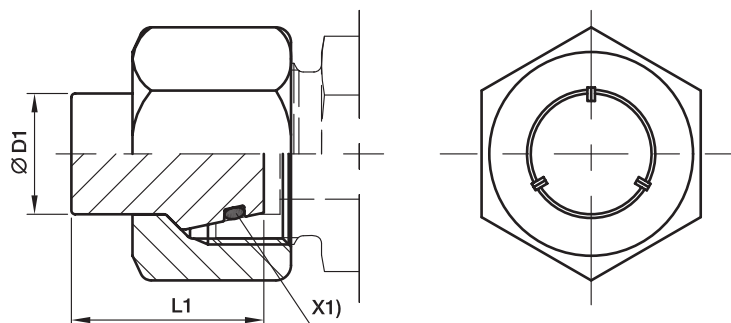

X1) O-ring OR

Serie	D1 	L1	Peso g/1 pezzo	Codice di ordinazione*	PN (bar) ¹⁾	
					CF	71
L ³⁾	06	18,5	15	VKAM06L	500	315
	08	18,5	24	VKAM08L	500	315
	10	20,0	33	VKAM10L	500	315
	12	20,5	46	VKAM12L	400	315
	15	20,5	73	VKAM15L	400	315
	18	22,5	111	VKAM18L	400	315
	22	25,0	162	VKAM22L	250	160
	28	25,5	220	VKAM28L	250	160
	35	30,0	376	VKAM35L	250	160
	42	30,0	558	VKAM42L	250	160
S ⁴⁾	06	18,5	23	VKAM06S	800	630
	08	18,5	29	VKAM08S	800	630
	10	20,0	46	VKAM10S	800	630
	12	20,5	55	VKAM12S	630	630
	14	22,5	83	VKAM14S	630	630
	16	23,5	106	VKAM16S	630	400
	20	28,5	180	VKAM20S	420	400
	25	29,0	322	VKAM25S	420	400
	30	30,5	398	VKAM30S	420	400
	38	33,0	647	VKAM38S	420	315

¹⁾ Pressione indicata = Articolo disponibile

³⁾ L = Serie leggera; ⁴⁾ S = Serie pesante

$\frac{PN \text{ (bar)}}{10} = PN \text{ (MPa)}$

Per informazioni sull'ordinazione di materiali di tenuta alternativi vedere pag. I7.

*Aggiungere i **suffissi** qui di seguito in base al materiale e alla superficie richiesti.

Suffissi codice di ordinazione			
Materiale	Suffisso superficie e materiale	Esempio	Materiale di tenuta standard (non occorre suffisso aggiuntivo)
Acciaio, zincato, esente da CromoVI	CF	VKAM16SCF	NBR
Acciaio inossidabile	71	VKAM16S71	VIT

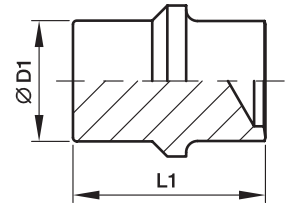
BUZ Tappo protettivo per coni

Serie	D1 	L1	Peso g/1 pezzo	Codice di ordinazione*	PN (bar) ¹⁾		
					CF	71	MS
L ³⁾	06	19,5	5	BUZ06L	315	315	200
	08	19,5	8	BUZ08L	315	315	200
	10	21,0	13	BUZ10L	315	315	200
	12	21,8	20	BUZ12L	315	315	200
	15	22,0	30	BUZ15L	315	315	200
	18	24,0	45	BUZ18L	315	315	200
	22	26,0	74	BUZ22L	160	160	100
	28	26,5	117	BUZ28L	160	160	100
	35	32,0	217	BUZ35L	160	160	100
	42	32,5	308	BUZ42L	160	160	100
S ⁴⁾	06	19,5	5	BUZ06L	630	630	400
	08	19,5	8	BUZ08L	630	630	400
	10	21,0	13	BUZ10L	630	630	400
	12	21,8	20	BUZ12L	630	630	400
	14	23,5	28	BUZ14S	630	630	400
	16	25,5	39	BUZ16S	400	400	250
	20	30,5	73	BUZ20S	400	400	250
	25	32,5	119	BUZ25S	400	400	250
	30	35,5	181	BUZ30S	400	400	250
	38	40,0	325	BUZ38S	315	315	200

¹⁾ Pressione indicata = Articolo disponibile

³⁾ L = Serie leggera; ⁴⁾ S = Serie pesante

$$\frac{\text{PN (bar)}}{10} = \text{PN (MPa)}$$

*Aggiungere i **suffissi** qui di seguito in base al materiale e alla superficie richiesti.

Suffissi codice di ordinazione		
Materiale	Suffisso superficie e materiale	Esempio
Acciaio, zincato, esente da CromoVI	CFX	BUZ16SCFX
Acciaio inossidabile	71X	BUZ16S71X
Ottone	MSX	BUZ16SMSX

BUZM Tappo protettivo con dado per coni

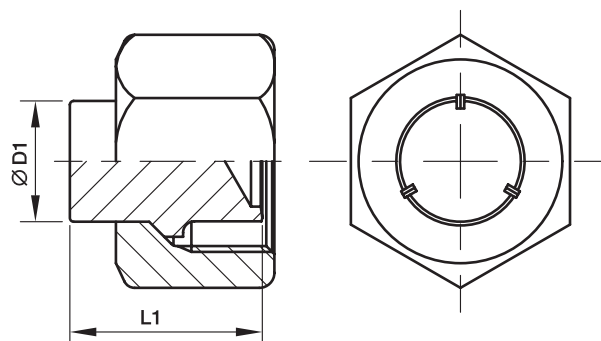

Serie	D1 	L1	Peso g/1 pezzo	Codice di ordinazione*	PN (bar) ¹⁾	
					CF	71
L ³⁾	06	19,5	15	BUZM06L	315	315
	08	19,5	23	BUZM08L	315	315
	10	21,0	31	BUZM10L	315	315
	12	21,8	45	BUZM12L	315	315
	15	22,0	71	BUZM15L	315	315
	18	24,0	107	BUZM18L	315	315
	22	26,0	156	BUZM22L	160	160
	28	26,5	206	BUZM28L	160	160
	35	32,0	354	BUZM35L	160	160
	42	32,5	524	BUZM42L	160	160
S ⁴⁾	06	19,5	23	BUZM06S	630	630
	08	19,5	28	BUZM08S	630	630
	10	21,0	44	BUZM10S	630	630
	12	21,8	54	BUZM12S	630	630
	14	23,5	81	BUZM14S	630	630
	16	25,5	105	BUZM16S	400	400
	20	30,5	176	BUZM20S	400	400
	25	32,5	321	BUZM25S	400	400
	30	35,5	399	BUZM30S	400	400
	38	40,0	664	BUZM38S	315	315

¹⁾ Pressione indicata = Articolo disponibile

³⁾ L = Serie leggera; ⁴⁾ S = Serie pesante

$$\frac{\text{PN (bar)}}{10} = \text{PN (MPa)}$$

*Aggiungere i **suffissi** qui di seguito in base al materiale e alla superficie richiesti.

Suffissi codice di ordinazione		
Materiale	Suffisso superficie e materiale	Esempio
Acciaio, zincato, esente da CromoVI	CF	BUZM16SCF
Acciaio inossidabile	71	BUZM16S71

GM Dado di bloccaggio per raccordi passaparatia

Per raccordi passaparatia SV e WSV

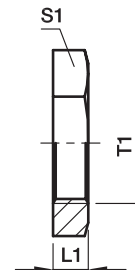

Serie	Diam. est. tubo	T1	L1	S1	Peso g/1 pezzo	Codice di ordinazione		
						Acciaio CF	Acciaio inossidabile 71	Ottone MS
L ³⁾	06	M 12×1,5	6	17	7	GM06LCFX	GM06L71X	GM06LMSX
	08	M 14×1,5	6	19	8	GM08LCFX	GM08L71X	GM08LMSX
	10	M 16×1,5	6	22	11	GM10LCFX	GM10L71X	GM10LMSX
	12	M 18×1,5	6	24	12	GM12LCFX	GM12L71X	GM12LMSX
	15	M 22×1,5	7	30	23	GM15LCFX	GM15L71X	GM15LMSX
	18	M 26×1,5	8	36	37	GM18LCFX	GM18L71X	GM18LMSX
	22	M 30×2,0	8	41	46	GM22LCFX	GM22L71X	GM22LMSX
	28	M 36×2,0	9	46	58	GM28LCFX	GM28L71X	GM28LMSX
	35	M 45×2,0	9	55	71	GM35LCFX	GM35L71X	GM35LMSX
	42	M 52×2,0	10	65	123	GM42LCFX	GM42L71X	GM42LMSX
S ⁴⁾	06	M 14×1,5	6	19	8	GM08LCFX	GM08L71X	GM06LMSX
	08	M 16×1,5	6	22	11	GM10LCFX	GM10L71X	GM10LMSX
	10	M 18×1,5	6	24	12	GM12LCFX	GM12L71X	GM12LMSX
	12	M 20×1,5	6	27	15	GM12SCFX	GM12S71X	GM12SMSX
	14	M 22×1,5	7	30	23	GM15LCFX	GM15L71X	GM15LMSX
	16	M 24×1,5	7	32	24	GM16SCFX	GM16S71X	GM16SMSX
	20	M 30×2,0	8	41	46	GM22LCFX	GM22L71X	GM22LMSX
	25	M 36×2,0	9	46	58	GM28LCFX	GM28L71X	GM28LMSX
	30	M 42×2,0	9	50	58	GM30SCFX	GM30S71X	GM30SMSX
	38	M 52×2,0	10	65	123	GM42LCFX	GM42L71X	GM42LMSX

³⁾ L = Serie leggera: ⁴⁾ S = Serie pesante

VH Ghiera di rinforzo

Per tubature metalliche con pareti sottili

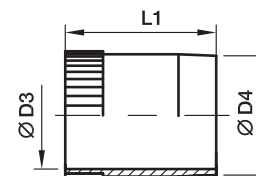

Diam. int. tubo	D3	D4	L1	Peso g/1 pezzo	Codice di ordinazione		
					Acciaio CF	Acciaio inossidabile 71	Ottone MS
4,00	2,6	3,8	14,0	0,7	VH04CFX	VH0471X	VH04MSX
4,50	3,1	4,3	14,0	0,8	VH04.5CFX	VH04.571X	VH04.5MSX
5,00	3,6	4,8	14,0	0,8	VH05CFX	VH0571X	VH05MSX
6,00	4,6	5,8	14,0	1,0	VH06CFX	VH0671X	VH06MSX
6,50	5,1	6,3	14,0	1,0	VH06.5CFX	VH06.571X	VH06.5MSX
7,00	5,6	6,8	15,5	1,3	VH07CFX	VH0771X	VH07MSX
8,00	6,6	7,8	15,5	1,6	VH08CFX	VH0871X	VH08MSX
9,00	7,6	8,8	15,5	1,8	VH09CFX	VH0971X	VH09MSX
10,00	8,6	9,8	15,5	2,1	VH10CFX	VH1071X	VH10MSX
10,05	8,6	9,8	15,5	2,1	VH10.05CFX	VH10.0571X	VH10.05MSX
10,50	9,1	10,3	15,5	2,3	VH10.5CFX	VH10.571X	VH10.5MSX
11,00	9,6	10,8	15,5	2,6	VH11CFX	VH1171X	VH11MSX
12,00	10,2	11,8	17,0	3,7	VH12CFX	VH1271X	VH12MSX
12,95	11,2	12,8	17,0	3,9	VH12.95CFX	VH12.9571X	VH12.95MSX
13,00	11,2	12,8	17,0	3,9	VH13CFX	VH1371X	VH13MSX
14,00	12,2	13,8	17,0	4,3	VH14CFX	VH1471X	VH14MSX
15,00	13,2	14,8	20,0	5,7	VH15CFX	VH1571X	VH15MSX
16,00	14,2	15,8	20,0	5,8	VH16.00CFX	VH16.0071X	VH16.00MSX
16,20	14,2	15,8	20,0	5,8	VH16CFX	VH1671X	VH16MSX
17,00	15,2	16,8	20,0	6,3	VH17CFX	VH1771X	VH17MSX
18,00	16,2	17,8	20,0	6,3	VH18CFX	VH1871X	VH18MSX
19,00	17,2	18,8	16,0	5,8	VH19CFX	VH1971X	VH19MSX
19,90	18,2	19,8	21,5	7,9	VH19.90CFX	VH19.9071X	VH19.90MSX
20,00	18,2	19,8	21,5	7,9	VH20CFX	VH2071X	VH20MSX
21,00	19,2	20,8	21,5	8,0	VH21CFX	VH2171X	VH21MSX
22,00	20,2	21,8	23,5	9,7	VH22CFX	VH2271X	VH22MSX
23,00	21,2	22,8	23,5	10,6	VH23CFX	VH2371X	VH23MSX
24,00	22,2	23,8	23,5	11,1	VH24CFX	VH2471X	VH24MSX
24,90	23,3	24,8	23,5	10,8	VH24.90CFX	VH24.9071X	VH2490MSX
25,00	23,2	24,8	23,5	10,8	VH25CFX	VH2571X	VH25MSX
26,00	24,2	25,8	23,5	12,7	VH26CFX	VH2671X	VH26MSX
27,00	25,2	26,8	23,5	12,2	VH27CFX	VH2771X	VH27MSX
30,00	27,8	29,8	26,5	18,7	VH30CFX	VH3071X	VH30MSX
31,00	28,8	30,8	26,5	20,7	VH31CFX	VH3171X	VH31MSX
32,00	29,8	31,8	26,5	19,2	VH32CFX	VH3271X	VH32MSX
32,10	29,8	31,8	26,5	19,2	VH32.10CFX	VH32.1071X	VH32.10MSX
33,00	30,8	32,8	26,5	19,9	VH33CFX	VH3371X	VH33MSX
34,00	31,8	33,8	26,5	26,5	VH34CFX	VH3471X	VH34MSX
37,80	35,8	37,7	31,0	19,5	VH37.8CFX	VH37.871X	VH37.8MSX
38,00	35,8	37,8	21,0	19,7	VH38CFX	VH3871X	VH38MSX
39,00	36,8	38,8	21,0	19,5	VH39CFX	VH3971X	VH39MSX

E Inserto di rinforzo tubo

Per tubature in plastica

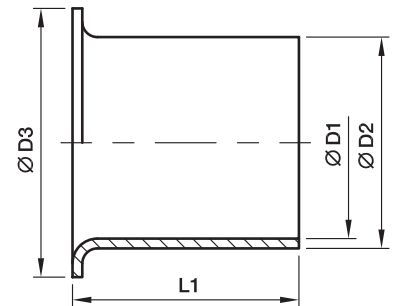

Diam. est. tubo	Diam. int. tubo	D1	D2	D3	L1	Peso g/1 pezzo	Codice di ordinazione Ottone
04	2,0	1,3	2,0	3,5	8	1	E04/02X
04	2,5	1,7	2,5	4,0	8	1	E04/2.5X
05	3,0	2,2	3,0	5,0	14	1	E0506/03X
06	3,0	2,2	3,0	5,0	14	1	E0506/03X
05	4,0	3,2	4,0	5,0	14	1	E0506/04X
06	4,0	3,2	4,0	5,0	14	1	E0506/04X
08	4,0	3,2	4,0	6,6	14	1	E08/04X
06	5,0	4,0	5,0	6,0	14	1	E06/05X
08	5,0	4,0	5,0	6,0	14	1	E08/05X
10	6,0	5,0	6,0	8,0	15	1	E0810/06X
08	6,0	5,0	6,0	8,0	15	1	E0810/06X
10	8,0	6,7	8,0	10,0	15	1	E10/08X
12	8,0	6,7	8,0	12,0	15	2	E12/08X
12	9,0	7,7	9,0	12,0	15	2	E12/09X
12	10,0	8,7	10,0	12,0	15	2	E1215/10X
15	12,0	10,7	12,0	14,8	15	3	E15/12X
15	12,5	11,2	12,5	14,8	15	3	E1516/12.5X
16	12,5	11,2	12,5	14,8	15	3	E1516/12.5X
18	14,0	12,7	14,0	17,8	15	4	E18/14X
18	16,0	14,7	16,0	17,8	20	4	E1820/16X
20	16,0	14,7	16,0	17,8	20	4	E1820/16X
22	18,0	16,7	18,0	21,8	16	5	E22/18X

DOZ Anello di tenuta in gomma EO-2

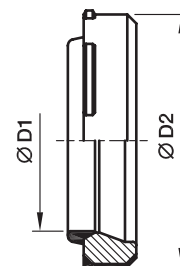

Direzione di assemblaggio:
il labbro di tenuta orientato
verso l'estremità del tubo

Serie	D1 	D2	Peso g/1 pezzo	Codice di ordinazione			
				Acciaio NBR	Acciaio FKM	Acciaio inossidabile FKM	Acciaio inossidabile NBR
LL ²⁾	04	6,8	1	DOZ04LL	—	—	—
	06	8,8	1	DOZ06LL	—	—	—
L ³⁾	06	10,3	1	DOZ06L	DOZ06LVIT	DOZ06L71	DOZ06LNBR71
	08	12,3	1	DOZ08L	DOZ08LVIT	DOZ08L71	DOZ08LNBR71
	10	14,3	2	DOZ10L	DOZ10LVIT	DOZ10L71	DOZ10LNBR71
	12	16,3	2	DOZ12L	DOZ12LVIT	DOZ12L71	DOZ12LNBR71
	15	20,3	3	DOZ15L	DOZ15LVIT	DOZ15L71	DOZ15LNBR71
	18	24,3	5	DOZ18L	DOZ18LVIT	DOZ18L71	DOZ18LNBR71
	22	27,7	6	DOZ22L	DOZ22LVIT	DOZ22L71	DOZ22LNBR71
	28	33,7	7	DOZ28L	DOZ28LVIT	DOZ28L71	DOZ28LNBR71
	35	42,7	14	DOZ35L	DOZ35LVIT	DOZ35L71	DOZ35LNBR71
	42	49,7	17	DOZ42L	DOZ42LVIT	DOZ42L71	DOZ42LNBR71
S ⁴⁾	06	12,3	2	DOZ06S	DOZ06SVIT	DOZ06S71	DOZ06SNBR71
	08	14,3	2	DOZ08S	DOZ08SVIT	DOZ08S71	DOZ08SNBR71
	10	16,3	3	DOZ10S	DOZ10SVIT	DOZ10S71	DOZ10SNBR71
	12	18,3	4	DOZ12S	DOZ12SVIT	DOZ12S71	DOZ12SNBR71
	14	20,3	4	DOZ14S	DOZ14SVIT	DOZ14S71	DOZ14SNBR71
	16	22,3	5	DOZ16S	DOZ16SVIT	DOZ16S71	DOZ16SNBR71
	20	27,7	9	DOZ20S	DOZ20SVIT	DOZ20S71	DOZ20SNBR71
	25	33,7	13	DOZ25S	DOZ25SVIT	DOZ25S71	DOZ25SNBR71
	30	39,7	18	DOZ30S	DOZ30SVIT	DOZ30S71	DOZ30SNBR71
	38	49,7	27	DOZ38S	DOZ38SVIT	DOZ38S71	DOZ38SNBR71

²⁾ LL = Serie ultraleggera; ³⁾ L = Serie leggera; ⁴⁾ S = Serie pesante

ED Guarnizione in gomma Eolastic (per filettature metriche e BSPP parallele)

Per Tipo: GE...ED, EGE...ED, EVGE...ED, EW...ED, EV...ED, ET...ED, EL...ED, VSTI...ED, RI...ED

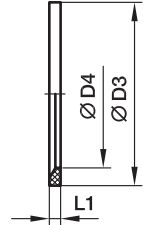



Terminale maschio Filettatura metrico T1	Terminale maschio Filettatura BSPP T1	D3	D4	L1	Peso g/1 pezzo	Codice di ordinazione NBR	Codice di ordinazione FKM
M 08x1,0		9,9	6,5	1,0	0,1	ED8X1X	ED8X1VITX
M 10x1,0	G 1/8 A	11,9	8,4	1,0	0,1	ED10X1X	ED10X1VITX
M 12x1,5		14,4	9,8	1,5	0,2	ED12X1.5X	ED12X1.5VITX
M 14x1,5	G 1/4 A	16,5	11,6	1,5	0,2	ED14X1.5X	ED14X1.5VITX
M 16x1,5		18,9	13,8	1,5	0,1	ED16X1.5X	ED16X1.5VITX
	G 3/8 A	18,9	14,7	1,5	0,2	ED3/8X	ED3/8VITX
M 18x1,5		20,9	15,7	1,5	0,1	ED18X1.5X	ED18X1.5VITX
M 20x1,5		22,9	17,8	1,5	0,2	ED20X1.5X	ED20X1.5VITX
	G 1/2 A	23,9	18,5	1,5	0,3	ED1/2X	ED1/2VITX
M 22x1,5		24,3	19,6	1,5	0,2	ED22X1.5X	ED22X1.5VITX
M 26x1,5	G 3/4 A	29,2	23,9	1,5	0,4	ED26X1.5X	ED26X1.5VITX
M 27x2,0	G 3/4 A	29,2	23,9	1,5	0,4	ED26X1.5X	ED26X1.5VITX
M 33x2,0	G 1 A	35,7	29,7	2,0	0,7	ED33X2X	ED33X2VITX
M 42x2,0	G 1 1/4 A	45,8	38,8	2,0	0,9	ED42X2X	ED42X2VITX
M 48x2,0	G 1 1/2 A	50,7	44,7	2,0	1,0	ED48X2X	ED48X2VITX

OR O-ring per raccordi con dado girevole EO 24° DKO

Per Tipo:

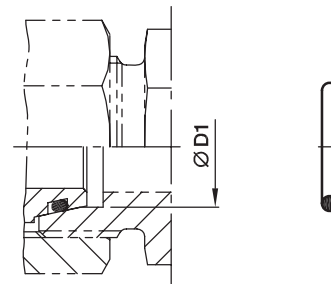
DA, EGE, EGEO, MAVE, EW, EV, ET, EL, RED, GZ, GZR, VKA, VKAM



Serie	D1 	O-ring NBR Durezza Shore 90 circa	O-ring FKM Durezza Shore 90 circa
L ³⁾	6	OR4.5X1.5X	OR4.5X1.5VITX
	8	OR6.5X1.5X	OR6.5X1.5VITX
	10	OR8.5X1.5X	OR8X1.5VITX
	12	OR10.5X1.5X	OR10X1.5VITX
	15	OR12.5X2X	OR12X2VITX
	18	OR16X2X	OR15X2VITX
	22	OR20X2X	OR20X2VITX
	28	OR26X2X	OR26X2VITX
	35	OR32X2.5X	OR32X2.5VITX
	42	OR39X2.5X	OR38X2.5VITX
S ⁴⁾	6	OR4.5X1.5X	OR4.5X1.5VITX
	8	OR6.5X1.5X	OR6.5X1.5VITX
	10	OR8.5X1.5X	OR8X1.5VITX
	12	OR10.5X1.5X	OR10X1.5VITX
	14	OR12X2X	OR12X2VITX
	16	OR14X2X	OR13X2VITX
	20	OR17X2.5X	OR16.3X2.4VITX
	25	OR22X2.5X	OR20.3X2.4VITX
	30	OR27X2.5X	OR25.3X2.4VITX
	38	OR35X2.5X	OR33.3X2.4VITX

³⁾ L = Serie leggera; ⁴⁾ S = Serie pesante

OR O-ring per estremità terminale maschio

Filettatura maschio metrica – O-ring (ISO 6149)

Filettatura maschio UN/UNF – O-ring (ISO 11926)

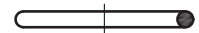
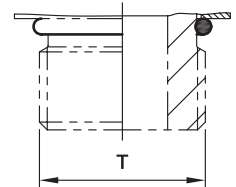

Tipi con filettatura metrica:
VSTI-OR, GEO, EGEO

Filettatura T	O-ring NBR	O-ring FKM
M 08x1,0	OR6.1X1.6	OR6.1X1.6VITX
M 10x1,0	OR8.1X1.6	OR8.1X1.6VITX
M 12x1,5	OR9.3X2.2	OR9.3X2.2VITX
M 14x1,5	OR11.3X2.2	OR11.3X2.2VITX
M 16x1,5	OR13.3X2.2	OR13.3X2.2VITX
M 18x1,5	OR15.3X2.2	OR15.3X2.2VITX
M 22x1,5	OR19.3X2.2	OR19.3X2.2VITX
M 27x2,0	OR23.6X2.9	OR23.6X2.9VITX
M 33x2,0	OR29.6X2.9	OR29.6X2.9VITX
M 42x2,0	OR38.6X2.9	OR38.6X2.9VITX
M 48x2,0	OR44.6X2.9	OR44.6X2.9VITX

Tipi con filettatura UN/UNF:
GE-UNF

Filettatura T	O-ring NBR	O-ring FKM
7/16-20 UNF	OR8.92X1.83	OR8.92X1.83VITX
9/16-18 UNF	OR11.89X1.98	OR11.89X1.98VITX
3/4-16 UNF	OR16.36X2.21	OR16.36X2.21VITX
7/8-14 UNF	OR19.18X2.46	OR19X2.5VITX
1 1/16-12 UN	OR23.47X2.95	OR23.47X2.95VITX
1 5/16-12 UN	OR29.74X2.95	OR29.74X2.95VITX
1 5/8-12 UN	OR37.46X3	OR37.46X3VITX
1 7/8-12 UN	OR43.69X3	OR43.69X3VITX

OR O-ring e anelli di ritenzione per estremità terminale maschio in acciaio

Filettatura BSPP orientabile – O-ring + anello di ritenzione (ISO 1179)

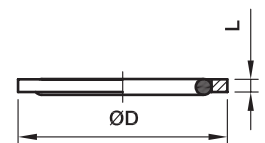
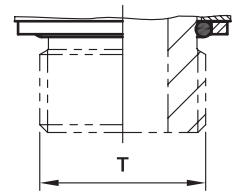

Tipi con filettatura parallela: WEE-R

Filettatura T	Acciaio			Codice di ordinazione Anello di ritenzione CF	Acciaio inossidabile			Codice di ordinazione Anello di ritenzione Acciaio inossidabile
	O-ring NBR	D	L		O-ring FKM	D	L	
G 1/8 A	OR8X1.88X	14,8	1,4	RRS1/8CF	*)	15,0	1,4	8207SS1/8
G 1/4 A	OR10.77X2.62X	19,8	1,9	RRS1/4CF	OR10.77X2.62VITX	19,5	1,9	8207SS1/4A
G 3/8 A	OR13.94X2.62X	22,8	2,0	RRS3/8CF	*)	23,5	1,9	8207SS3/8A
G 1/2 A	OR18X3.15X	27,8	2,6	RRS1/2CF	OR17.96X2.62VITX	28,5	1,9	8207SS1/2
G 3/4 A	OR23X3X	32,8	2,5	RRS3/4CF	OR23.47X2.62VITX	34,5	1,9	8207SS3/4
G 1 A	OR29.74X3.53X	40,8	2,5	RRS1CF	*)	43,5	2,6	8207SS1A
G 1 1/4 A	OR37.69X3.53X	50,8	2,6	RRS11/4CF	*)	52,5	2,6	8207SS11/4
G 1 1/2 A	OR44.04X3.53X	55,8	2,6	RRS11/2CF	*)	60,0	2,6	8207SS11/2

*) come per la versione in acciaio

Suffissi codice di ordinazione	
Materiale	Esempio
NBR	OR10.77X2.62X
FKM	OR10.77X2.62VITX

OR O-ring per raccordi banjo WH/TH

Per WH / TH	Per WH / TH	O-ring NBR	O-ring FKM
06LM/LR		OR9.3X1.5X	OR9.3X1.5VITX
08LM/LR	06SM/SR	OR12.5X1.5X	OR12.5X1.5VITX
10LM/LR	08SM/SR	OR12.5X1.5X	OR12.5X1.5VITX
12LM/LR	10SM/SR	OR16X1.5X	OR16X1.5VITX
	12SR	OR16X1.5X	OR16X1.5VITX
15LM	12SM	OR18X1.5X	OR18X1.5VITX
15LR	14SM/SR	OR20X1.5X	OR20X1.5VITX
18LM/LR	16SM/SR	OR20X1.5X	OR20X1.5VITX
22LM/LR	20SM/SR	OR25X2X	OR25X2VITX
28LM/LR	25SM/SR	OR33X2.5X	OR33X2.5VITX
35LM/LR	30SM/SR	OR41X2.5X	OR41X2.5VITX
42LM/LR	38SM/SR	OR46X3X	OR46X3VITX

OR O-ring per raccordi banjo a gomito SWVE..M/R KDSOMD

Per SWVE..M/R KDSOMD	O-ring NBR
04LLR/- 06LLR/LLM 08LLR/LLM 06LR/LM	OR9X1.2X
08LM 06SM	OR10X1.5X
08LR 06SR 10LR/LM 08SR/LM	OR12.5X1.5X
12LR/LM 10SR/LM 12SR	OR15X1.5X
15LM 12SM	OR16X1.5X
15LR 14SR/-	OR19X1.5X
18LR/LM 16SR/SM	OR20X1.5X
22LR/LM 20SR/SM	OR25.12X1.78X
28LR/LM 25SR/SM	OR33X2.5X
35LR/LM 30SR/SM	OR41X2.5X
42LR/LM 38SR/SM	OR46X3.0X

DKI Anello di tenuta per connettori portamanometri

Filettatura femmina	D1	D2	L1	Peso g/1 pezzo	Codice di ordinazione	
					Acciaio CF	Acciaio inossidabile 71
G 1/4	6	11,3	4,5	2,5	DKI1/4CFX	DKI1/471X
G 1/2	12	18,5	5,0	5,0	DKI1/2CFX	DKI1/271X

KDS Anello di tenuta in gomma per raccordi banjo WH/TH in acciaio

Per connessioni con lamatura ampia e ridotta

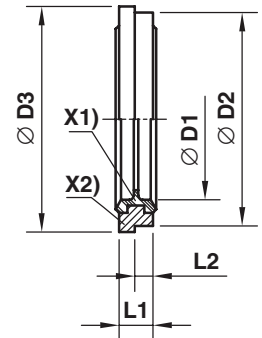

X1) Guarnizione NBR
X2) Anello di supporto (acciaio)

Filettatura maschio metrica	Filettatura maschio BSPP	D1	D2	D3	L1	L2	Peso g/1 pezzo	Codice di ordinazione	
								Acciaio/NBR	Acciaio/FKM
M 10x1,0	G 1/8 A	10,3	14,9	16,0	2,5	1,1	2	KDS10X	KDS10VITX
M 12x1,5		12,3	17,0	18,0	3,0	1,6	2	KDS12X	KDS12VITX
M 14x1,5	G 1/4 A	14,3	18,9	20,0	3,0	1,6	2	KDS14X	KDS14VITX
M 16x1,5	G 3/8 A	17,0	21,9	24,0	3,0	2,1	3	KDS16X	KDS16VITX
M 18x1,5		18,3	23,9	23,9	3,0		4	KDS18X	KDS18VITX
M 22x1,5	G 1/2 A	22,3	26,9	30,0	4,5	2,6	7	KDS22X	KDS22VITX
M 26x1,5		26,3	31,9	35,0	3,5	2,6	7	KDS26X	KDS26VITX
M 27x2,0	G 3/4 A	27,3	32,9	38,0	3,5	2,6	8	KDS27X	KDS27VITX
M 33x2,0	G 1 A	33,6	39,9	42,0	3,5	2,6	10	KDS33X	KDS33VITX
M 42x2,0	G 1 1/4 A	42,4	49,9	49,9	3,5		12	KDS42X	KDS42VITX
M 48x2,0	G 1 1/2 A	48,4	55,9	60,0	3,5	2,6	16	KDS48X	KDS48VITX

KD Anello di tenuta in gomma per raccordi banjo WH/TH in acciaio inossidabile

Per connessioni con lamatura ampia

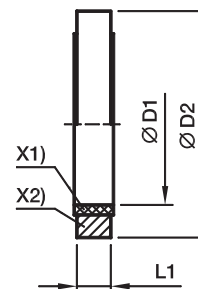

X1) Guarnizione PTFE

X2) Anello di supporto (acciaio inossidabile)

Per WH e TH	Per filettatura	D1	D2	L1	Peso g/1 pezzo	Codice di ordinazione
06LRKD71	G 1/8 A	10,0	17,0	2,5	2	KD1/871
08LR/06SRKD71	G 1/4 A	13,5	22,0	3,0	4	KD1/471
10LR/08SRKD71	G 1/4 A	13,5	22,0	3,0	4	KD1/471
12LR/10SRKD71	G 3/8 A	17,1	27,0	3,0	6	KD3/871
12SRKD71	G 3/8 A	17,1	27,0	3,0	6	KD3/871
15LR/14SRKD71	G 1/2 A	21,4	32,0	4,5	12	KD1/271
18LR/16SRKD71	G 1/2 A	21,4	32,0	4,5	12	KD1/271
22LR/20SRKD71	G 3/4 A	26,8	41,0	3,5	17	KD3/471
28LR/25SRKD71	G 1 A	33,5	46,0	3,5	17	KD171
35LR/30SRKD71	G 1 1/4 A	42,4	57,0	3,5	26	KD11/471
42LR/38SRKD71	G 1 1/2 A	48,4	64,0	3,5	35	KD11/271
06LMKD71	M 10×1,0	10,3	17,0	2,5	2	KD1071
08LM/06SMKD71	M 12×1,5	12,3	22,0	3,0	5	KD1271
10LM/08SMKD71	M 14×1,5	14,3	22,5	3,0	5	KD1471
12LM/10SMKD71	M 16×1,5	16,4	27,0	3,0	9	KD1671
15LM/12SMKD71	M 18×1,5	18,4	29,0	3,0	9	KD1871
14SMKD71	M 20×1,5	20,4	32,0	3,0	9	KD2071
18LM/16SMKD71	M 22×1,5	22,4	32,0	4,5	12	KD2271
22LMKD71	M 26×1,5	26,4	41,0	3,5	18	KD2671
20SMKD71	M 27×2,0	27,4	41,0	3,5	18	KD2771
28LM/25SMKD71	M 33×2,0	33,5	46,0	3,5	17	KD171
35LM/30SMKD71	M 42×2,0	42,4	57,0	3,5	26	KD11/471
42LM/38SMKD71	M 48×2,0	48,4	64,0	3,5	35	KD11/271

DKAZ Anello di tenuta

Per banjo DSVW per basse pressioni

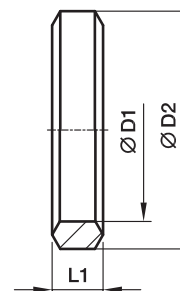

Per DSVW		Filettatura metrica parallela	D1	D2	L1	Peso g/1 pezzo	Codice di ordinazione Acciaio CF
06LM		M 10×1,0	10,1	14	3,2	2	DKAZ10CFX
08LM	06SM	M 12×1,5	12,1	17	4,2	3	DKAZ12CFX
10LM	08SM	M 14×1,5	14,1	19	4,5	4	DKAZ14CFX
12LM	10SM	M 16×1,5	16,1	21	4,5	4	DKAZ16CFX
15LM	12SM	M 18×1,5	18,1	23	4,5	5	DKAZ18CFX
	14SM	M 20×1,5	20,1	25	4,5	5	DKAZ20CFX
18LM	16SM	M 22×1,5	22,1	27	4,5	6	DKAZ22CFX
22LM		M 26×1,5	26,1	31	4,5	7	DKAZ26CFX
	20SM	M 27×2,0	27,1	32	5,0	8	DKAZ27CFX
28LM	25SM	M 33×2,0	33,1	39	6,0	15	DKAZ33CFX
35LM	30SM	M 42×2,0	42,1	49	6,5	22	DKAZ11/4CFX
42LM	38SM	M 48×2,0	48,1	55	6,5	25	DKAZ11/2CFX

Per DSVW		Filettatura BSPP parallela	D1	D2	L1	Peso g/1 pezzo	Codice di ordinazione Acciaio CF
06LR		G 1/8 A	9,8	14	3,2	2	DKAZ1/8CFX
08LR/10LR	06SR/08SR	G 1/4 A	13,3	18	4,5	4	DKAZ1/4CFX
12LR	10SR/12SR	G 3/8 A	16,8	22	4,5	5	DKAZ3/8CFX
15LR/18LR	14SR/16SR	G 1/2 A	21,1	26	5,0	6	DKAZ1/2CFX
22LR	20SR	G 3/4 A	26,6	32	5,0	11	DKAZ3/4CFX
28LR	25SR	G 1 A	33,4	39	6,0	14	DKAZ1CFX
35LR	30SR	G 1 1/4 A	42,1	49	6,5	22	DKAZ11/4CFX
42LR	38SR	G 1 1/2 A	48,1	55	6,5	25	DKAZ11/2CFX

DKA Anello di tenuta

Per raccordi banjo WH/TH e SWVE

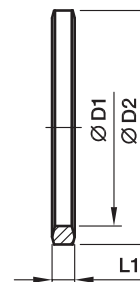

Filettatura BSPP	D1	D2	L1	Peso g/1 pezzo	Codice di ordinazione	
					Acciaio CF	Acciaio inossidabile 71
G 1/8 A	9,8	14	2,5	1	DKA1/8CFX	DKA1/871X
G 1/4 A	13,3	18	3,0	3	DKA1/4CFX	DKA1/471X
G 3/8 A	16,8	22	3,0	3	DKA3/8CFX	DKA3/871X
G 1/2 A	21,1	26	4,5	6	DKA1/2X4.5CFX	DKA1/2X4.571X
G 3/4 A	26,6	32	3,5	6	DKA3/4CFX	DKA3/471X
G 1 A	33,4	39	3,5	8	DKA1CFX	DKA171X
G 1 1/4 A	42,1	49	3,5	12	DKA11/4CFX	DKA11/471X
G 1 1/2 A	48,1	55	3,5	15	DKA11/2CFX	DKA11/271X

Filettatura terminale maschio	D1	D2	L1	Peso g/1 pezzo	Codice di ordinazione	
					Acciaio CF	Acciaio inossidabile 71
M 08x1,0	8,1	12	2,5	1	DKA08CFX	
M 10x1,0	10,1	14	3,0	1	DKA10CFX	DKA1071X
M 12x1,5	12,1	17	3,0	2	DKA12CFX	DKA1271X
M 14x1,5	14,1	19	3,0	3	DKA14CFX	DKA1471X
M 16x1,5	16,1	21	3,0	3	DKA16CFX	DKA1671X
M 18x1,5	18,1	23	3,0	3	DKA18CFX	DKA1871X
M 20x1,5	20,1	25	3,0	4	DKA20CFX	DKA2071X
M 22x1,5	22,1	27	4,5	6	DKA22X4.5CFX	DKA22X4.571X
M 26x1,5	26,1	31	3,5	6	DKA26X3.5CFX	DKA26X3.571X
M 27x2,0	27,1	32	3,5	6	DKA27CFX	DKA2771X
M 33x2,0	33,1	39	3,5	8	DKA33CFX	DKA3371X
M 42x2,0	42,1	49	3,5	12	DKA11/4CFX	DKA11/471X
M 48x2,0	48,1	55	3,5	15	DKA11/2CFX	DKA11/271X